

# GR-1600XL

160 TON CAPACITY

**ROUGH  
TERRAIN  
CRANE**



Photo: Hydraulic offset jib





Photo: Hydraulic offset jib

**Crane capacity:** 160 US ton (145 metric ton)  
**6-section long boom:** 42.8 ft - 200.1 ft  
(13.1 m - 61.0 m)  
**2-staged bi-fold jib:** 33.8 ft / 59.1 ft  
(10.3 m / 18.0 m)  
**Max. lifting height:** 201.1 ft (61.3 m)[Boom]  
302.5 ft (92.2 m)[Boom + jib + \*insert jib]  
**Max. working radius:** 185 ft (56.0 m)[Boom]  
231 ft (70.5 m)[Boom + jib + \*insert jib]  
\*Optional

# **ROUGH TERRAIN CRANE GR-1600XL**

## **The world's largest rough terrain crane just got better!**

Introducing a brand-new option for Tadano's rough terrain crane with the highest lifting capacity in class worldwide! Get more done than ever before with our new heavy lift jib. Where previous generations of cranes would be limited, the GR-1600XL can lift higher and heavier loads with this addition. We are also now offering an insert lattice jib, which is a flexible option for operating at height in large facilities such as refineries or petrochemical factories. These new items were designed to maximize work efficiency and expand your abilities. The GR-1600XL never stops evolving.



# NEW FEATURES

## HELLO-NET

The HELLO-NET system is used to monitor crane activity straight from your computer or mobile device. You have the ability to view work history, machine position data and maintenance information. HELLO-NET has advanced customer support between the owners' site and TADANO Group.

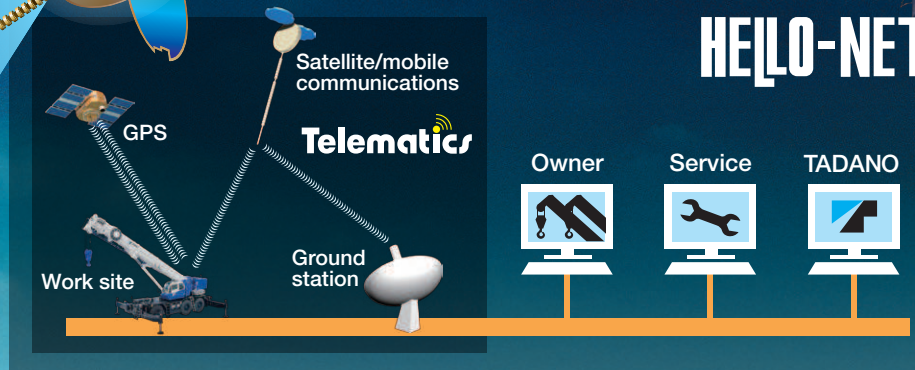

Note: Available in the U.S. and Canada, other countries may vary. Contact your distributor or [sales@tadano-cranes.com](mailto:sales@tadano-cranes.com) for details.

## Eco mode

The Eco Mode system controls the maximum engine speed at the time of crane operation. Due to an unnecessary rise in the engine speed that occurs when accelerated to excess, the system enables CO<sub>2</sub> emissions and fuel consumption to decrease by a maximum of 13 % with the Eco Mode I deployed, and a maximum of 21 % when the Eco Mode II is applied, and the noise level is reduced.



## Positive control

The Positive Control system effectively controls the quantity of hydraulic pump discharge during the crane operation in response to the amount of movement applied to the operating lever. When the crane is on standby the Positive Control system keeps the quantity of hydraulic pump discharge to a minimum. This process leads to a maximum 20 % reduction in CO<sub>2</sub> emissions and consumption.



## Fuel monitoring

The Fuel Monitoring system constantly monitors and displays on the AML-C screen information on fuel consuming conditions. Checking the indicator enables you to prevent wasteful acceleration and wasteful standby.



During crane operation    At traveling

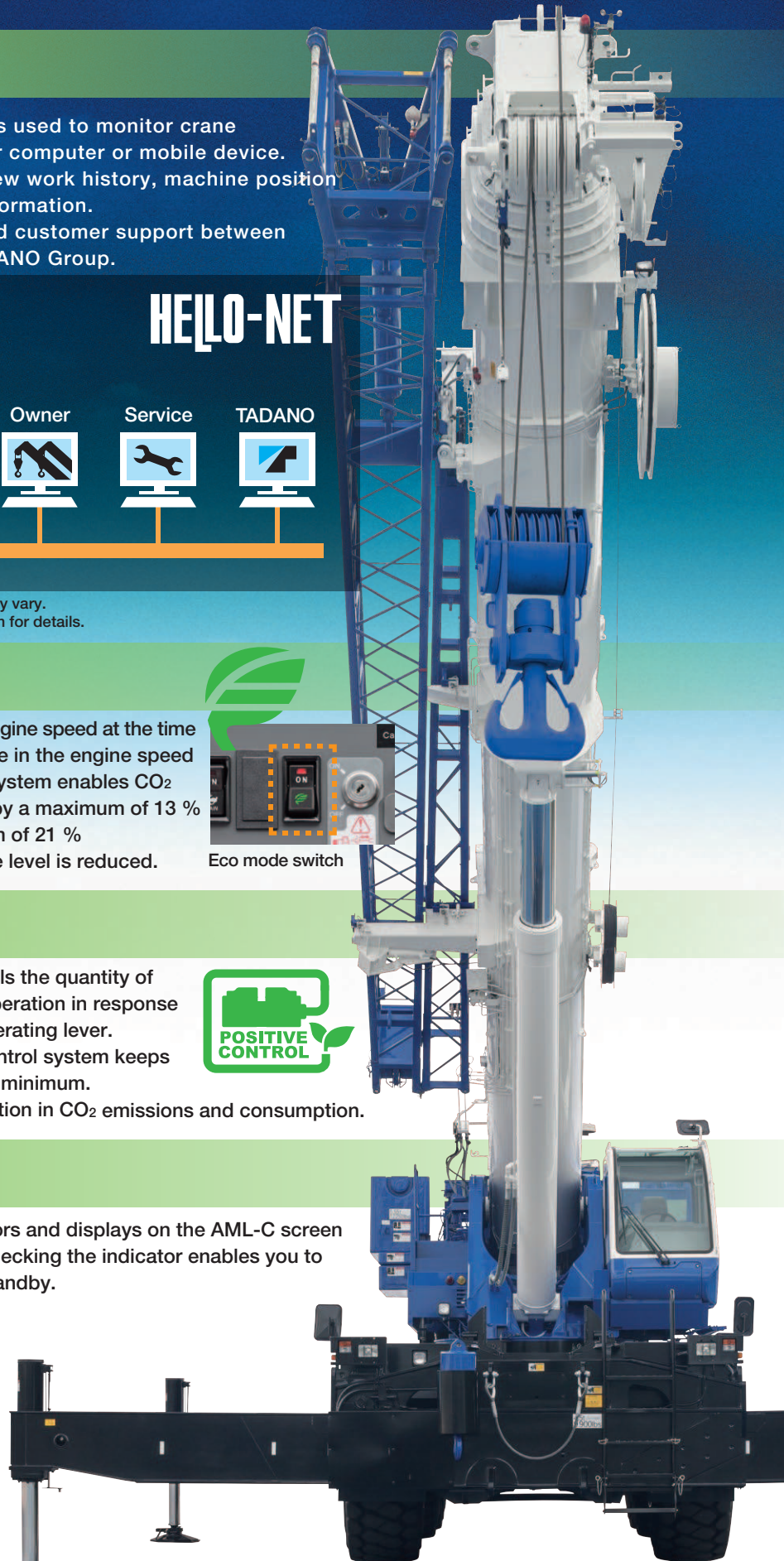



# Crane

The rounded boom is made of high tensile steel, which allows for decreased boom weight and increased boom strength.

The high performance AML-C comes standard and helps the operator maintain safe operations.

Ultimate boom for rough terrain crane

## Single telescopic cylinder

For extension and retraction of sections, the 6-section, box type construction consists of 1 base section and 5 telescopic sections and are extended by a single telescoping cylinder.

All sections are fully extended/retracted automatically and locked in the selected working position.

## Outline of telescoping mode

The boom telescope of this crane is performed with one telescoping cylinder. Each telescopic section is extended and fixed with pins in sequence from the top with several telescoping modes based on the designated job plan.

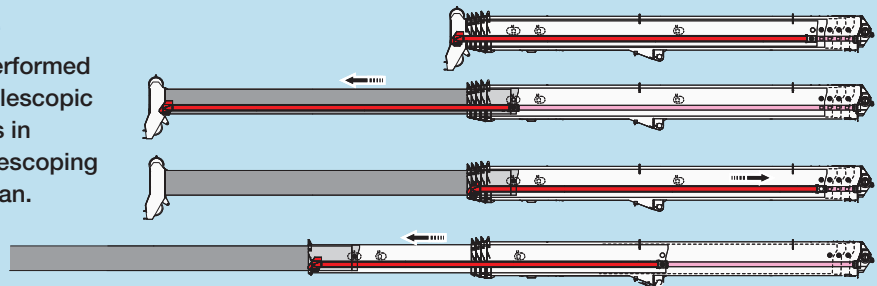

## Telescoping status display

A single cylinder and each section of the boom's actual condition are displayed on the AML by activating the telescoping monitor switch.



Telescoping status indicator

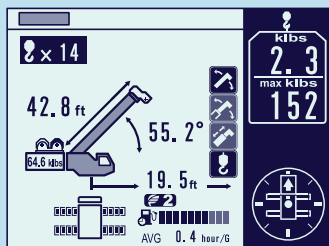

## AML displays load moment indicator

No.	ft	1	2	3	4	5
1	42.8	0	0	0	0	0
2	57.2	0	0	0	0	45
3	71.7	0	0	0	0	90
4	86.1	0	0	0	45	90
5	100.5	0	0	0	90	90
6	114.9	0	0	40	90	90
7	129.3	0	0	90	90	90
8	143.7	0	40	90	90	90
9	158.1	0	90	90	90	90

Telescoping menu screen

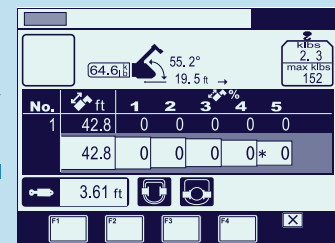

Telescoping status screen

## Two winches with cable follower

Both the main winch and the auxiliary winch have powerful line pull and operate at high speeds thus enhancing work efficiency.

\*Maximum permissible line pull may be affected by wire rope strength.

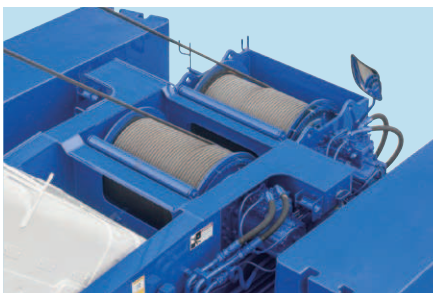

## New crane structure

During the development of the structural shape of the crane, \*FEM analysis was applied to achieve a design tailored for optimal operation. The slewing frames' structure ensures a highly rigid, compact style that is well suited for the overall planned design of the crane. Continuing the TADANO tradition of excellence and innovation.

\*FEM: Finite Element Method

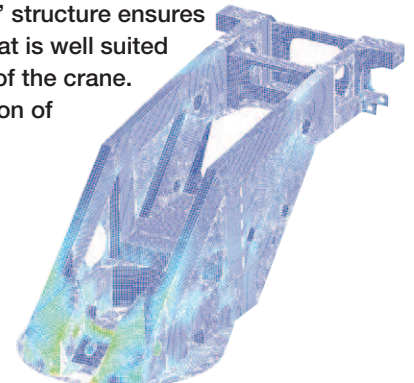



## Hydraulic offset jib (5°-40°) \*Optional

Hydraulic offset jib can be adjusted between 5° to 40° by the jib tilt cylinder.

5°-40°



Jib tilt cylinder

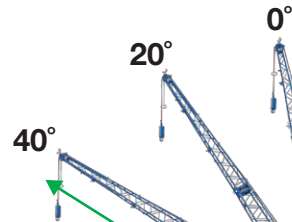

33.8 ft / 59.1 ft  
(10.3 m / 18.0 m)

### Bi-fold jib

A two-stage, bi-fold lattice-type jib can be offset at 0°, 20°, and 40° to enable the operator to carry out jobs that require extra reaching ability.

Max. lifting height:

201.1 ft (61.3 m)  
[Boom]

302.5 ft (92.2 m)  
[Boom + jib + \*insert jib]

Insert Lattice jib (2 pcs.)  
\*Optional

45.9 ft (14.0 m)

Insert Lattice jib (1 pce.)  
\*Optional

23.0 ft (7.0 m)

Longest boom  
in its class

42.8 ft-200.1 ft  
(13.1 m-61.0 m)

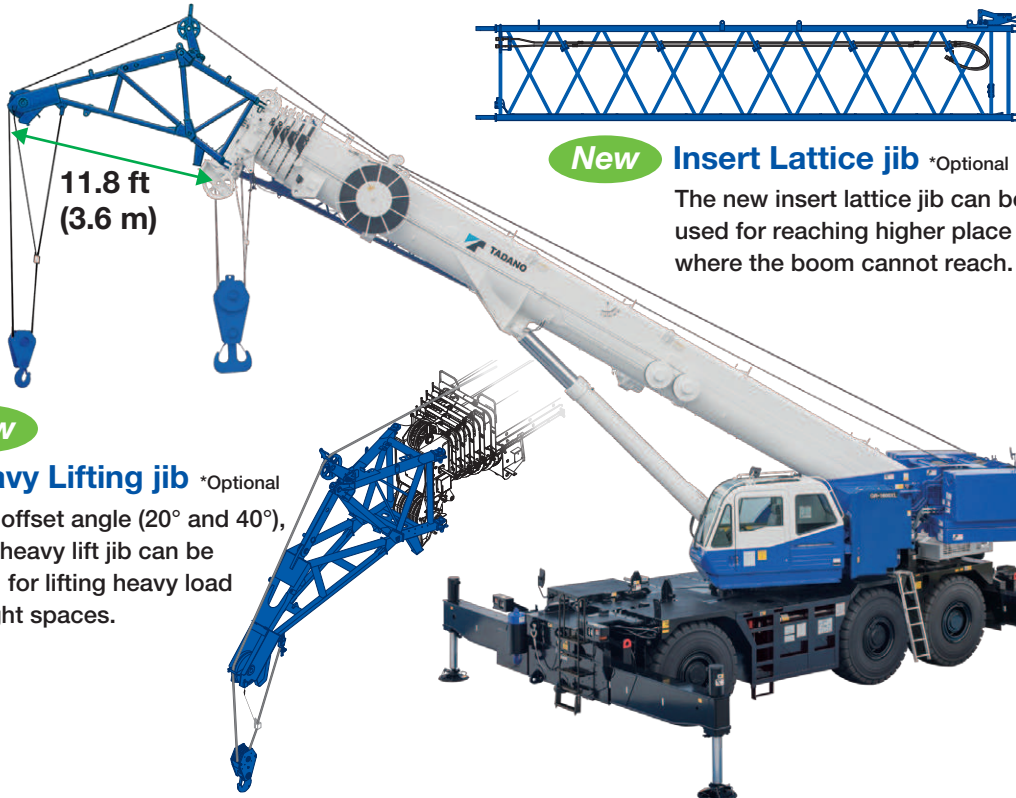

11.8 ft  
(3.6 m)

**New** Insert Lattice jib \*Optional

The new insert lattice jib can be used for reaching higher place where the boom cannot reach.

**New**

### Heavy Lifting jib \*Optional

Two offset angle (20° and 40°), new heavy lift jib can be used for lifting heavy load in tight spaces.

### Tiltable cab

You can operate the crane comfortably by tilting the cab during high hoisting operations such as lifting with the jib.

The cab tilting angle is between 0° and 15°.



Cab tilt indicator and switch



81.5°



Photo: Manual offset jib



# Load moment indicator [AML-C]



Tadano's AML-C is easy to use, innovative in design, displays important information to the operator as well as enables the operator to preset a custom working environment. For example, the AML-C shows the boom angle, boom length, load radius, operating pressure of the elevating cylinder, the extension width of the outriggers, slewing position, rated lifting capacity and present hook load. These features allow the AML-C to move seamlessly through all lifting operations without having to change configurations or input new codes to make the lift.

The AML-C safety features provide both audible and visual warnings. When an operation approaches the load limit Tadano's slow stop function engages to avoid shock loads.



AML lamp

## Control of asymmetric extension width of outriggers

When operating the crane with the asymmetric outriggers extended, the AML-C detects the extension width of all of the Crane's outriggers (front, rear, left and right) to measure maximum work capacity in each area. When slewing the boom from the longer outrigger area to the shorter outrigger area, the AML-C detects the motion and displays the maximum capacity according to the extension width of each of the outriggers, and brings the motion to a slow stop before it reaches the maximum capacity. Therefore, even in the case of operator error, the AML-C's slow stop function will help to minimize any safety risk.

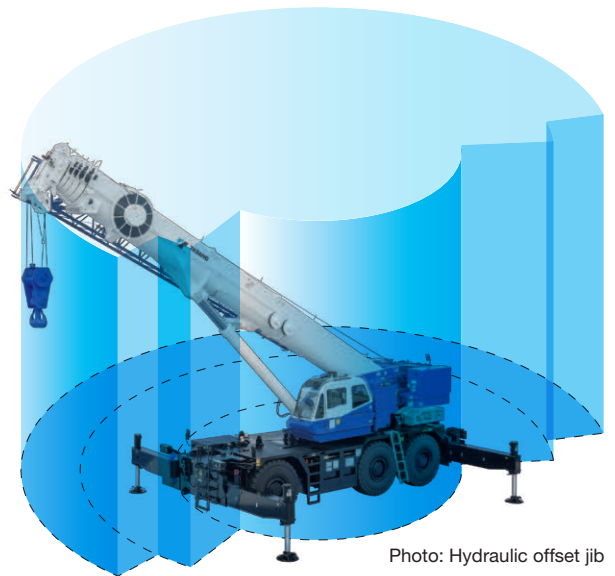
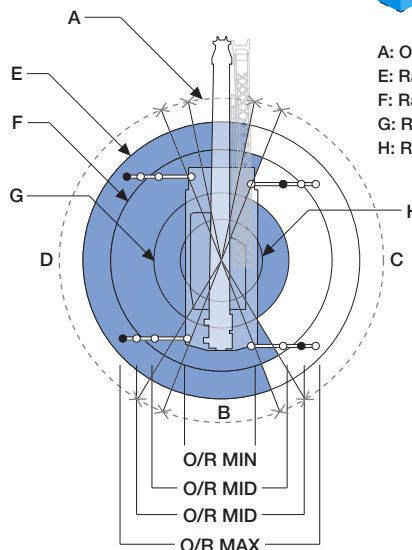
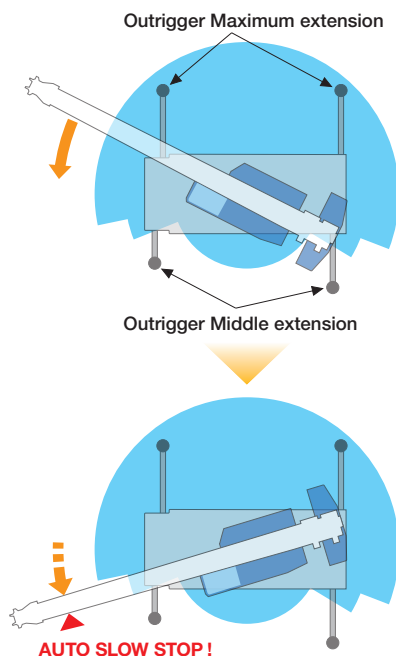
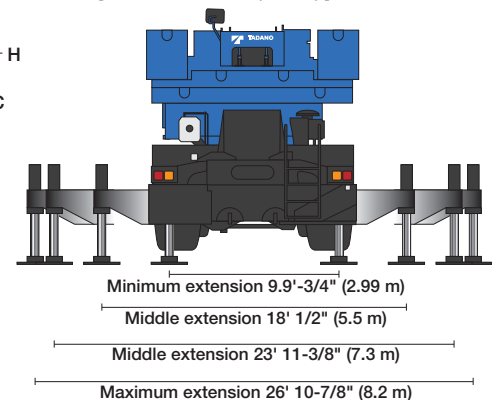

Photo: Hydraulic offset jib



- A: Over-front B: Over-rear C: Over-side D: Over-side
- E: Rated Load [ O/R max. 26' 10-7/8" (8.2 m) ]
- F: Rated Load [ O/R mid. 23' 11-3/8" (7.3 m) ]
- G: Rated Load [ O/R mid. 18' 1/2" (5.5 m) ]
- H: Rated Load [ O/R min. 9.9'-3/4" (2.99 m) ]







## Operator comfort

The crane cab provides improved livability and offers the operator a comfortable working environment.

The control levers are smooth and responsive to the operators touch.



Front steps



Rear steps



Right side steps



Left side steps



Air conditioning and heating  
Hot-water heater and air conditioning.



Tool box



Aviation obstruction light (optional)  
and anemometer (optional)



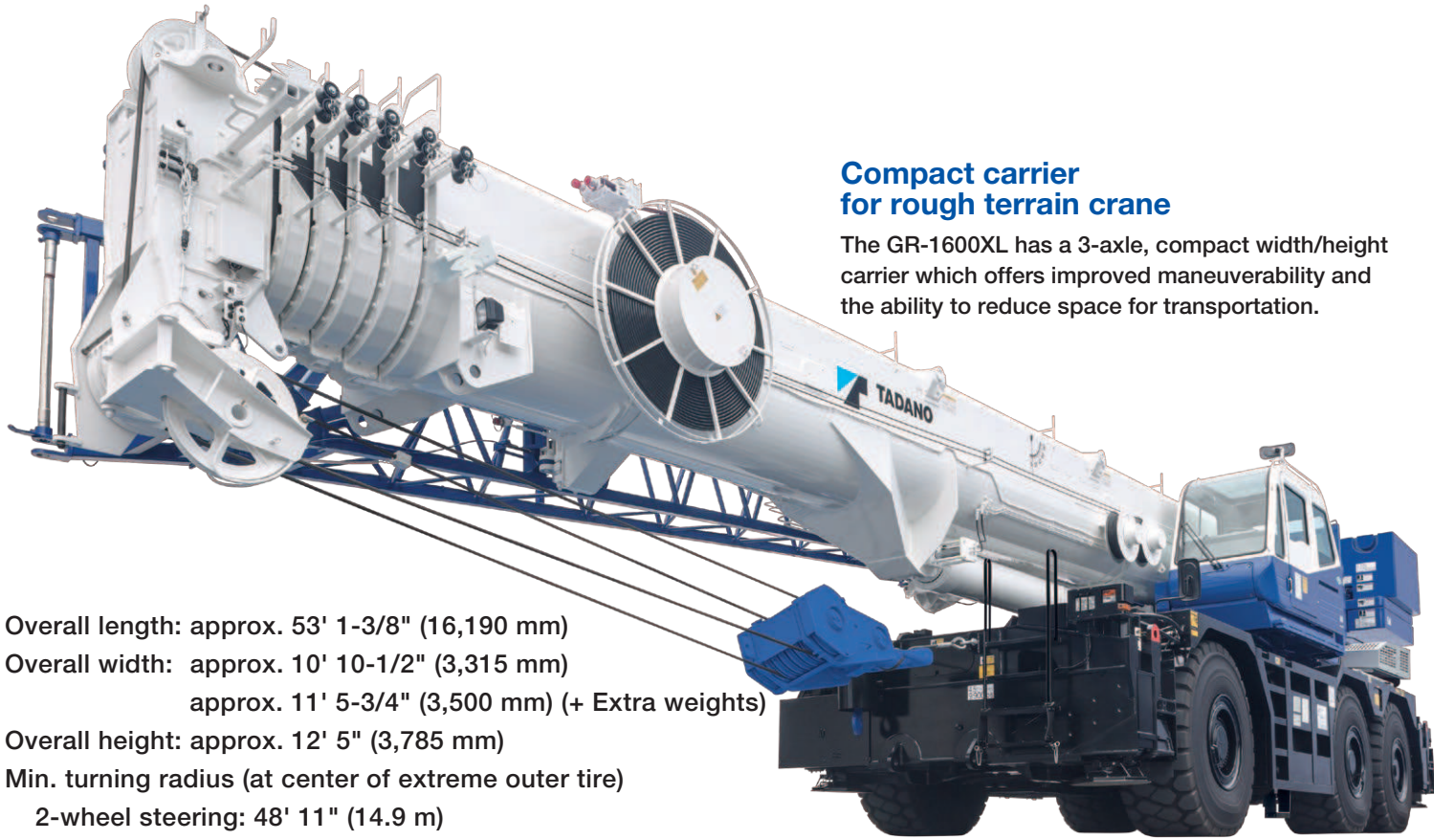

## Compact carrier for rough terrain crane

The GR-1600XL has a 3-axle, compact width/height carrier which offers improved maneuverability and the ability to reduce space for transportation.

- Overall length: approx. 53' 1-3/8" (16,190 mm)
- Overall width: approx. 10' 10-1/2" (3,315 mm)  
approx. 11' 5-3/4" (3,500 mm) (+ Extra weights)
- Overall height: approx. 12' 5" (3,785 mm)
- Min. turning radius (at center of extreme outer tire)
  - 2-wheel steering: 48' 11" (14.9 m)
  - 6-wheel steering: 32' 6" (9.9 m)

Max. traveling speed (with counterweight): 9.3 mph (15 km/h)

Gradeability (tan  $\theta$ ): 52 % (with 40,100 lbs (18.2 t) counterweight), \*57 %

\* Machine should be operated within the limit of engine crankcase design (30°: Cummins QSB6.7 EPA) Tier4 Final).

Photo: Hydraulic offset jib

## Smooth transmission

- Electronically controlled, fully automatic transmission.
- Torque converter driving full power shift with driving axle selector.
- 5 forward and 2 reverse speeds, constant mesh.
  - 2 speeds - high range - 2 wheel drive ; 4 wheel drive
  - 3 speeds - low range - 4 wheel drive

## New carrier frame

The new carrier frame design was developed and built so that its lightweight is compatible with its high rigidity to achieve an advanced level of performance. As a result, the rigidity was enhanced enabling highly stabilized maneuverability.

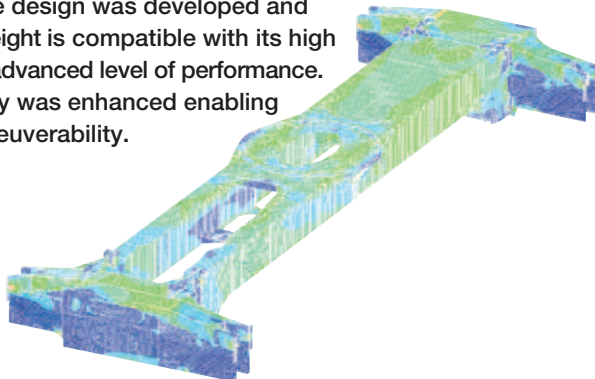

## High performance engine

Cummins QSB6.7 EPA) Tier4 Final  
4 cycle, turbo charged and after cooled,  
6-cylinder, direct injection diesel type.

Horse power (kW): Gross 270 (201) at 2,400 min<sup>-1</sup> {rpm}  
Max. torque ft-lb (Nm): 730 (990) at 2,000 min<sup>-1</sup> {rpm}





### Axle

- 1st: Full floating type, steering and driving axle with planetary reduction and open differential.
- 2nd: Steering and not driving axle.
- 3rd: Full floating type, steering and driving axle with planetary reduction and open differential.

### Brake systems

- Service: Air over hydraulic disc brakes on all 6 wheels.
- Parking/Emergency: Spring applied-air released brake acting on input shaft of 1st and 3rd axle.
- Auxiliary: Electro-pneumatic operated exhaust brake.

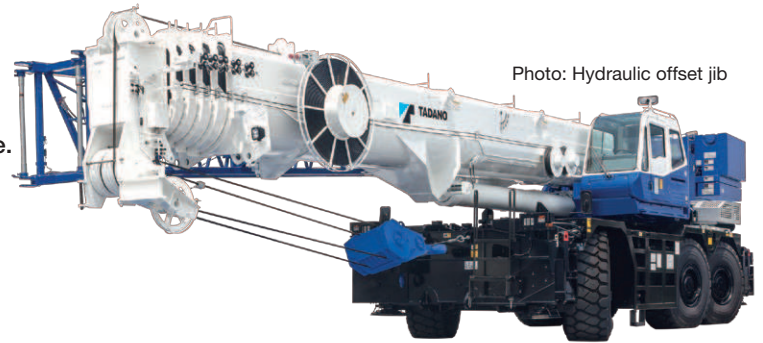
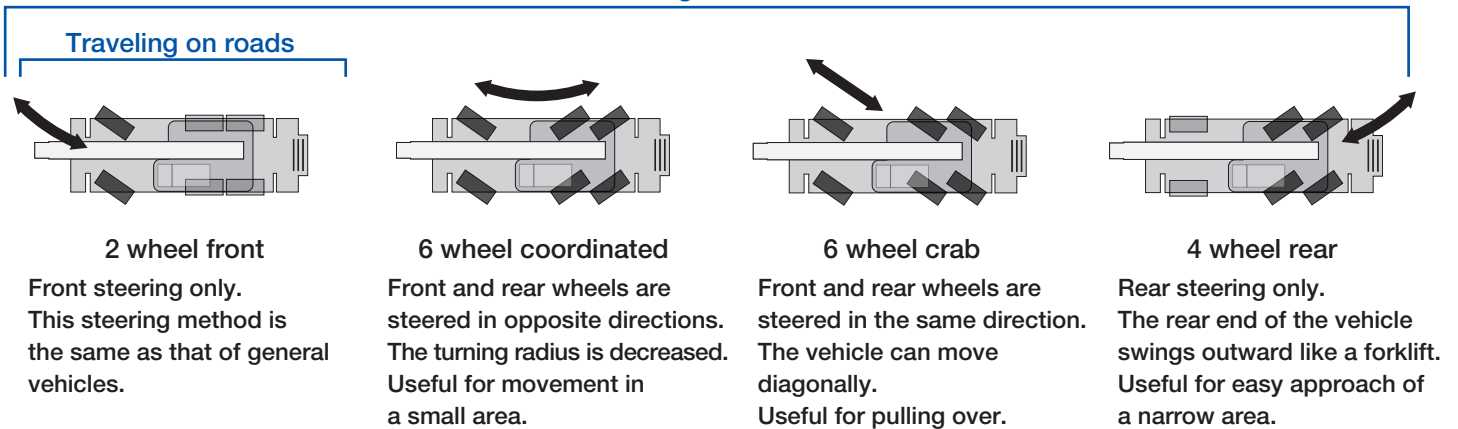

Photo: Hydraulic offset jib

### 4 steering modes

Hydraulic power steering controlled by steering wheel.

#### Driving in work site





# Mounting and dismounting systems

The GR-1600XL has several mounting and dismounting systems for traveling and transportation. Only the boom mounting/dismounting system is optional.

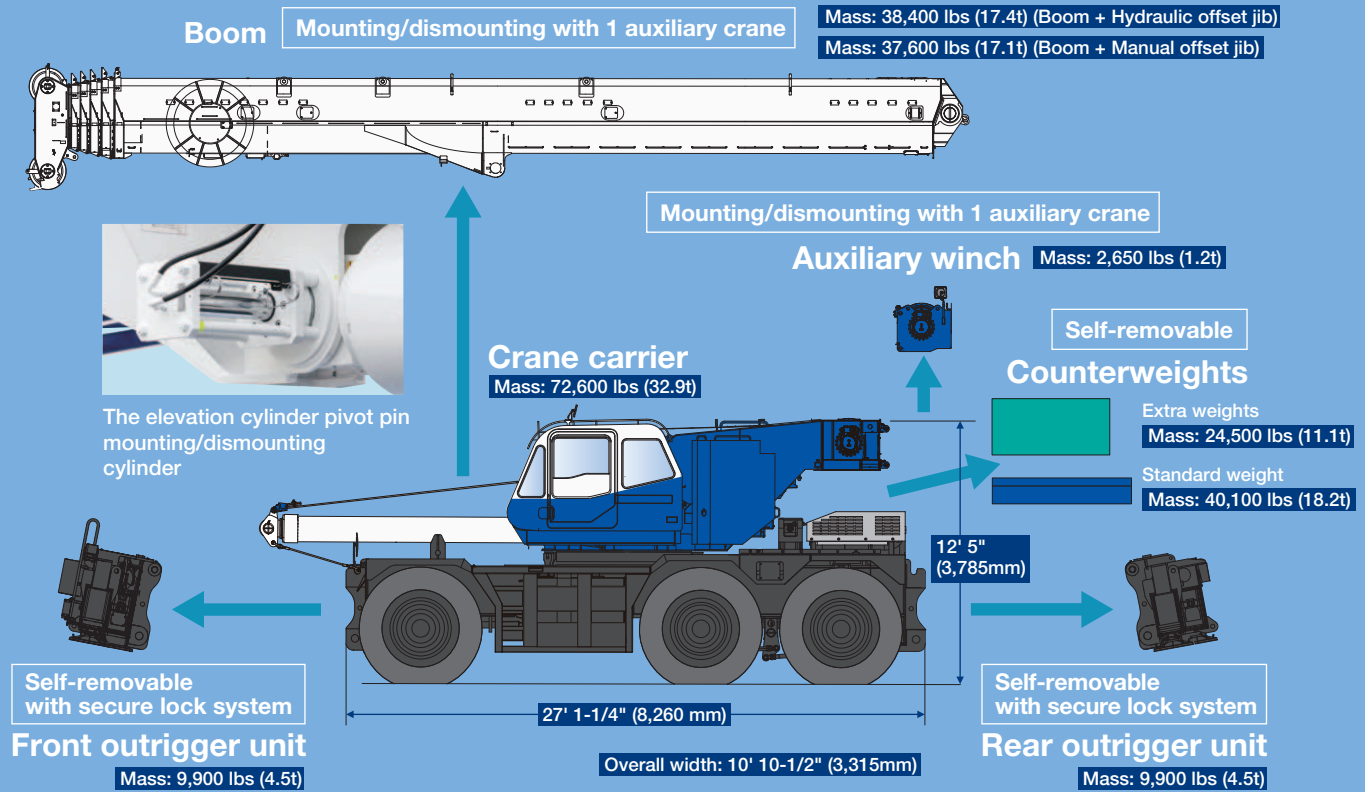

## Counterweight combinations

**Standard weight + Extra weights**  
 Mass: 40,100 lbs + 12,250 lbs + 12,250 lbs  
 (18.2 t) (5.55 t) (5.55 t)

**Standard weight only**  
 Mass: 40,100 lbs  
 (18.2 t)



Counterweight/outrigger mounting/dismounting remote controller

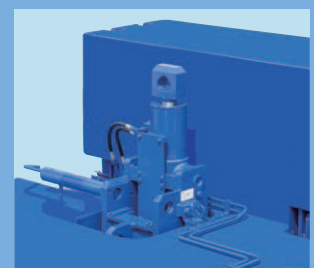
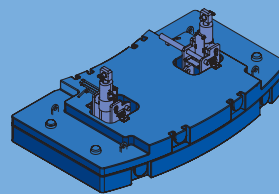
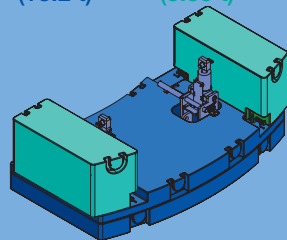

Counterweight mounting/dismounting cylinder

## Self-removable counterweight

Counterweight along with an auxiliary winch is hydraulically mounting/dismounting; in addition, dismantled counterweights can be lifted and moved for transport without a helper crane, as well as being re-mounted at a work site for operation.

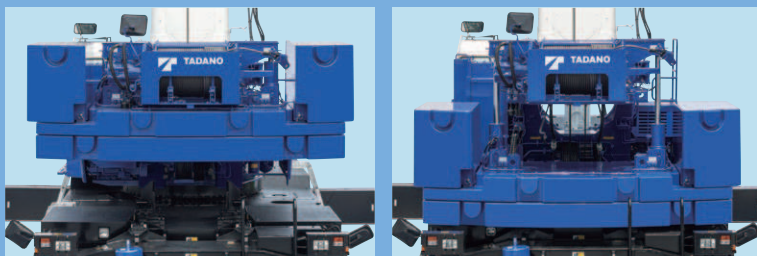



## SPECIFICATIONS

<b>MAXIMUM CAPACITY</b>	320,000 lbs at 8 ft		
<b>PERFORMANCE</b>	Max. traveling Speed (with counterweight) 9.3 mph (15 km/h) Gradeability (tan $\theta$ ) 52% (at stall) *57% (with 40,100 lbs (18.2 t) counterweight) *Machine should be operated within limit of engine crankcase design. (30°: Cummins QSB6.7 EPA Tier4 Final)		
<b>WEIGHT</b>	Gross vehicle mass 200,191 lbs      200,960 lbs*      *Hydraulic offset jib -1st axle 63,275 lbs      64,812 lbs* -2nd axle 67,933 lbs      67,550 lbs* -3rd axle 68,983 lbs      68,599 lbs*		
<b>MIN. TURNING RADIUS</b>	48' 11" (14.9 m) (2-wheel steer) 32' 6" (9.9 m) (4-wheel steer) (at center of extreme outer tire)		
<b>BOOM</b>	6-sections extended by a single telescoping cylinder. Fully retracted length 42.8 ft (13.1 m) Fully extended length 200.1 ft (61.0 m) Extension speed 157.3 ft in 450 seconds Angle -1.5° to 81.5° Elevation speed 20° to 60° in 28 s		
<b>JIB</b>	Two-staged bi-fold lattice type. • Triple offset (0°, 20°, 40°) type. • *Offset angle (5° to 40°) by tilt cylinder. Length 33.8 ft, 59.1 ft (10.3 m, 18.0 m)      *Hydraulic offset jib		
<b>MAIN WINCH</b>	Variable speed type with grooved drum driven by hydraulic axial piston motor. Single line pull 15,900 lbs (7,200 kg) Single line speed 446 fpm (at 4th layer) Wire rope 3/4" x 1,050' (19 mm x 320 m) (diameter x length)		
<b>AUXILIARY WINCH</b>	Variable speed type with grooved drum driven by hydraulic axial piston motor. Single line pull 15,900 lbs (7,200 kg) Single line speed 446 fpm (at 4th layer) Wire rope 3/4" x 738' (19 mm x 225 m) (diameter x length)		
<b>SLEWING</b>	Slewing speed 1.3 min <sup>-1</sup> {rpm} Tail slewing radius 15' 1" (4.6 m)		
<b>HYDRAULIC SYSTEM</b>	Pumps... 2 variable piston pumps for crane functions. Tandem gear pump for steering, slewing and other equipment. Control valves... Multiple valves actuated by pilot pressure with integral pressure relief valves. Reservoir... 202 gallon (763 lit.) capacity. External sight level gauge. Oil cooler... Air cooled fan type.		

<b>LOAD MOMENT INDICATOR (TADANO AML-C)</b>	Following information is displayed. • Control lever lockout function with audible and visual pre-warning • Boom position indicator • Outrigger state indicator • Boom angle / boom length / jib offset angle / jib length / load radius / rated lifting capacities / actual loads read out • Ratio of actual load moment to rated load moment indication • Automatic speed reduction and slow stop function on boom elevation and slewing • Working condition register switch • Load radius / boom angle / tip height / slewing range preset function • External warning lamp • Tare function • Fuel consumption monitor • Main winch / auxiliary winch select • Drum rotation indicator (audible and visible type) main and auxiliary winch
<b>OUTRIGGERS</b>	Four hydraulic, beam and jack outriggers. Vertical jack cylinders equipped with integral holding valve. Each outrigger beam and jack is controlled independently from cab. Four outrigger extension lengths are provided with corresponding "RATED LIFTING CAPACITIES" for crane operation in confined areas. Extension width Max. ... 26' 10-7/8" (8.20 m) Mid. ... 23' 11-3/8" & 18' 1/2" (7.30 m & 5.50 m) Min. ... 9' 9-3/4" (2.99 m) Float size (diameter) ... 1' 10-1/2" (0.57 m)
<b>CARRIER</b>	Rear engine, left-hand steering, driving axle 2-way selected type by manual switch. 6 x 2 1st drive, 6 x 4 1st and 3rd drive
<b>ENGINE</b>	Model..... Cummins QSB6.7 EPA Tier4 Final Type ..... 4-cycle, turbo charged and after cooled, 6-cylinder, direct injection diesel engine. Piston displacement, cu. In (liters)... 409 (6.700) Horsepower (kW)... Gross 270 (201) at 2,000 min <sup>-1</sup> {rpm} Max. torque ft-lb (N·m)... 730 (990) at 1,500 min <sup>-1</sup> {rpm}
<b>TRANSMISSION</b>	Electronically controlled full automatic transmission.
<b>STEERING</b>	Hydraulic power steering controlled by steering wheel. 4 steering modes available: 2-wheel front, 4-wheel rear 6-wheel coordinated, 6-wheel crab
<b>SUSPENSION</b>	1st..... Rigid mounted to frame. 2nd, 3rd..... "Hydro-Pneumatic suspension cylinders" with leveling adjustment and oscillation.
<b>TIRES</b>	26.5R25☆☆☆, Air pressure: 94 psi (650 kPa)
<b>FUEL TANK CAPACITY</b>	79.2 gallon (300 lit.)

## WORKING RANGE

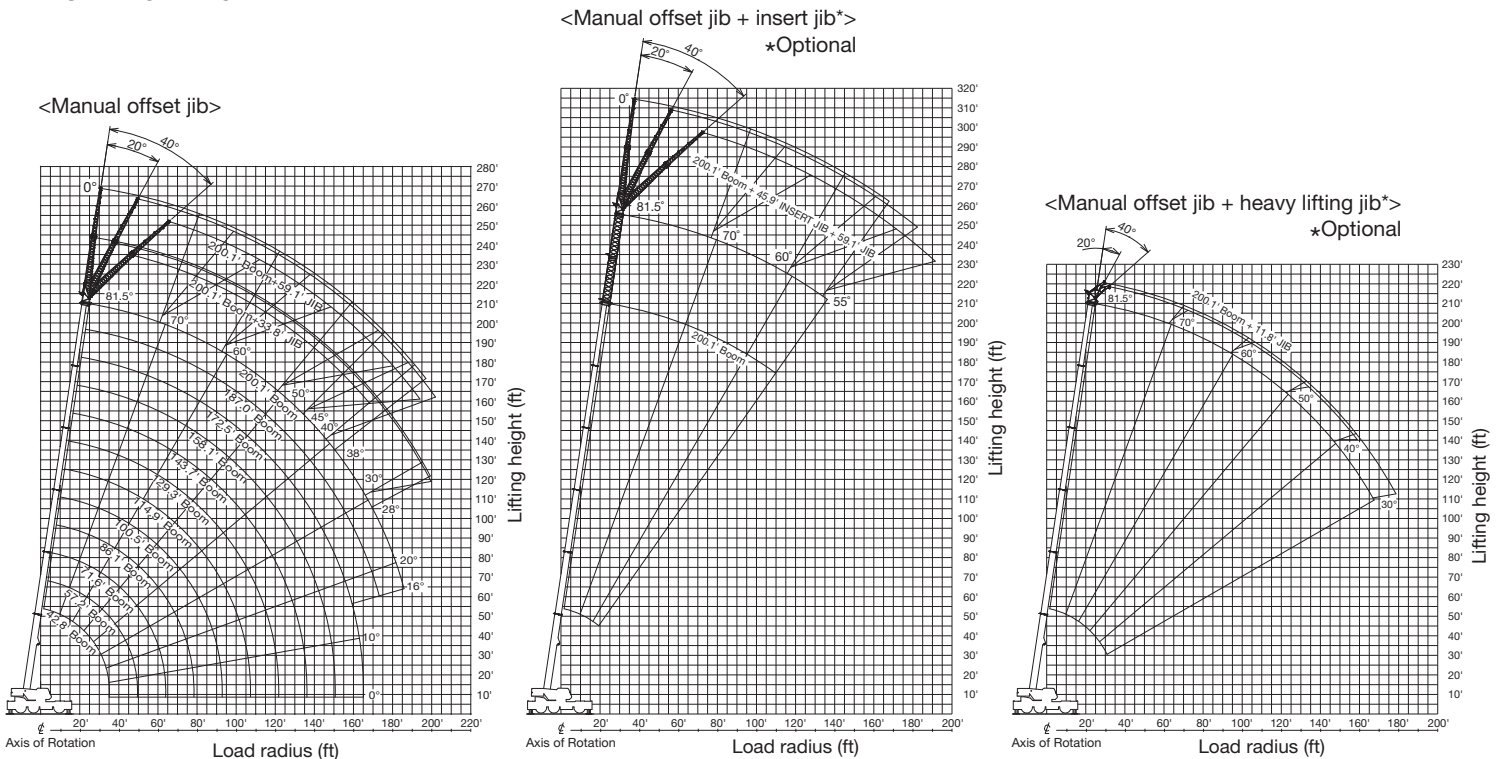

Note: Some specifications are subject to change.



**DIMENSIONS**

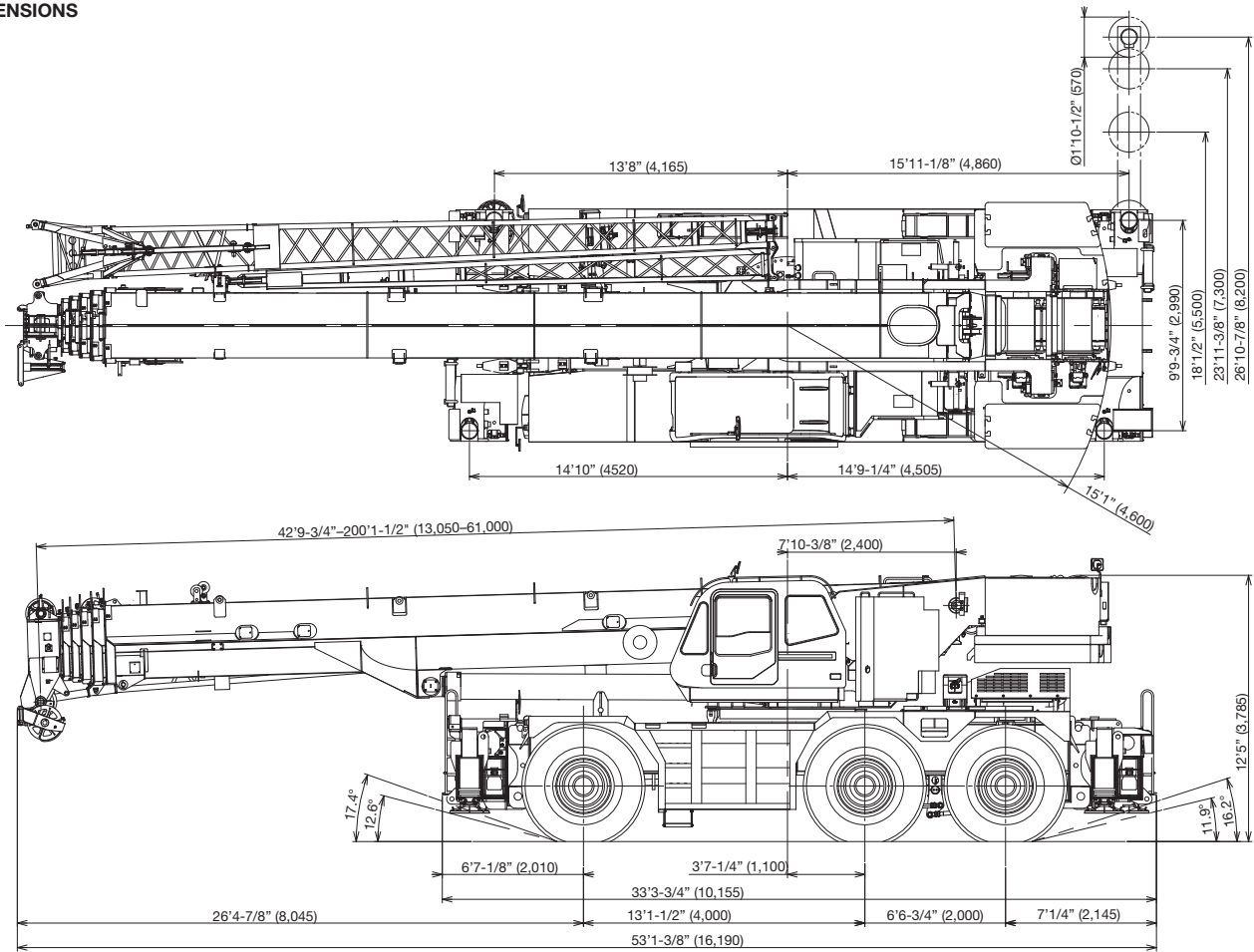

Working range and dimension chart show Manual offset jib model.



Front



Left



Rear



Right

Note: Some specifications are subject to change.



**TADANO AMERICA Corporation**

4242 West Greens Road, Houston, TX 77066

Tel: 281-869-0030 Fax: 281-869-0040

www.tadanoamerica.com Email: sales@tadano-cranes.com

Parts Hotline: 713-865-1041 Service Hotline: 281-869-5925

2015-12

Printed in USA

Courtesy of Crane.Market