

SIMON AERIALS INC.
10600 W. Brown Deer Road
Milwaukee, Wisconsin 53224
Phone (414) 355-0802
TWX: 910-262-3310
FAX: (414) 355-0832
Cable: SIMON MIL

**MODEL
CONSTRUCTOR
AT30C**

**AT40C
(S/N 5000 & UP)**

PART NO. 89-444017

SIMON

SERVICE MANUAL

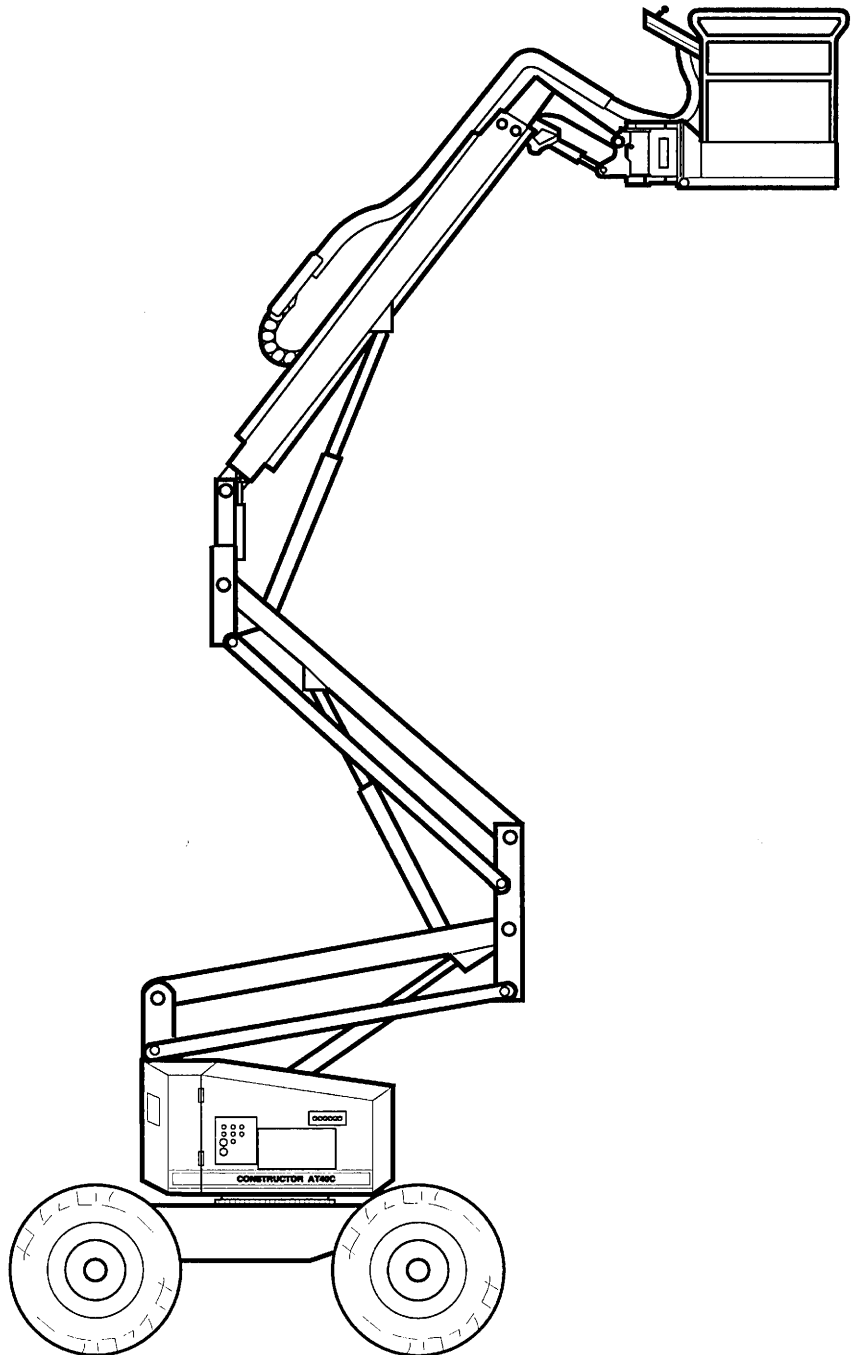

**REVISION C.2
APRIL, 1993**

TABLE OF CONTENTS

INTRODUCTION 5

MACHINE SPECIFICATIONS 6

COMPONENT LOCATORS 8

LUBRICATION DIAGRAM / CHART 12

EMERGENCY SYSTEM AND PROCEDURES

EMERGENCY ELECTRIC PUMP 15

EMERGENCY MOVEMENT 15

EMERGENCY LOWERING 15

HYDRAULIC FLUID

HANDLING PRECAUTIONS 17

FLUID RECOMMENDATIONS 17

FLUID CONTAMINATION CHECKS 17

SYSTEM FLUSHING PROCEDURE 18

HYDRAULIC SYSTEM

PUMPS 20

MANIFOLD 22

RELIEF VALVES 25

HYDRAULIC FLUID RESERVOIR 25

FILTERS 25

BOOM LIFT SYSTEM 26

BOOM TELESCOPE SYSTEM 27

SWING SYSTEM 28

PLATFORM LEVELING SYSTEM 29

TABLE OF CONTENTS (CONTINUED)

HYDRAULIC SYSTEM (CONTINUED)

PLATFORM ROTATE SYSTEM 30

STEER SYSTEM 31

DRIVE SYSTEM

HYDROSTATIC TRANSMISSION 32

CONTROL CIRCUIT COMPONENTS 33

DRIVELINE BRAKE/SPEED REDUCER 34

TRANSFER CASE 35

DRIVE SHAFTS AND COUPLINGS 35

REAR DRIVE AXLE 36

FRONT DRIVE AND STEERING AXLE 36

DRIVE SYSTEM TROUBLESHOOTING 37

DRIVE SYSTEM SERVICE 38

ELECTRICAL SYSTEM

12 VOLT BATTERY 42

EMERGENCY STOP BUTTONS 43

FOOT PEDAL SWITCH 43

TILT ALARM 44

MOVEMENT ALARM 45

RELAYS 45

CIRCUIT BREAKER 45

AUTOMATIC WARNING BEACON 45

TABLE OF CONTENTS (CONTINUED)

MECHANICAL COMPONENTS

TIRES	46
WHEELS AND LUG NUTS	46
SUPERSTRUCTURE	46
HOSES AND CABLES	46
TOWING PACKAGE	46
MISCELLANEOUS EQUIPMENT	46
CYLINDER PIVOT PINS AND PIN BUSHINGS	47
PIN REPLACEMENT	47
BOOM LIFT CYLINDERS	48
BOOM TELESCOPE (EXTEND) CYLINDER	49
WEAR PADS	50
PLATFORM LEVEL CYLINDERS	51
SAFETY AND INSTRUCTIONAL LABELS	52
TROUBLESHOOTING	54
MAINTENANCE SCHEDULE	57
ROUTINE SERVICING	58
OPERATIONAL CHECKLISTS	62
MAINTENANCE CHART	68
ELECTRICAL AND HYDRAULIC SCHEMATICS	71

INTRODUCTION

This Service Manual is designed to provide you with the instructions needed to properly maintain the SIMON AERIALS INC. CONSTRUCTOR Self-Propelled Aerial Work Platform. When used in conjunction with the Operators, Parts and Component Repair manuals (provided separately) this Service Manual will assist you in making all necessary adjustments or repairs.

Simon Aerial Mobile Platforms are designed and built to provide many years of safe, dependable service. To obtain full benefits from your CONSTRUCTOR, always follow the proper operating and maintenance procedures. Only trained, authorized personnel should be allowed to operate or service this machine. Service personnel should read and study the Operators, Service, Parts and Component Repair Manuals in order to gain a thorough understanding of the unit prior to making any repairs.

Service personnel and machine operators must understand and comply with all warnings and instructional decals on the body of the machine, and at the ground and platform control stations.

MODIFICATIONS OF THIS MACHINE FROM THE ORIGINAL DESIGN ARE STRICTLY FORBIDDEN WITHOUT WRITTEN PERMISSION FROM SIMON AERIALS INC., AND WILL VOID ANY REMAINING WARRANTY.

SIMON AERIALS INC. reserves the right to change, improve, modify or expand features of its equipment. Therefore, specifications, models or equipment are subject to change without notice, and without incurring obligations.

All SIMON AERIALS INC. manuals are periodically updated to reflect changes that occur in the equipment. Please contact the factory for information regarding changes which may affect your machine.

MACHINE SPECIFICATIONS

CONSTRUCTOR AT40C AND AT30C

	AT30C	AT40C
WORKING HEIGHT	39 FT (11.89 M)	47 FT 6 IN. (14.48 M)
PLATFORM HEIGHT	33 FT (10.06 M)	41 FT 6 IN. (12.65 M)
HORIZONTAL OUTREACH	22 FT (6.71 M)	24 FT 6 IN. (7.47 M)
SUPERSTRUCTURE ROTATION, STOP TO STOP .	360°	360°
PLATFORM CAPACITY (UNRESTRICTED)	500 LBS. (227 KG)	500 LBS. (227 KG)
PLATFORM DIMENSIONS	60 IN. x 30 IN. (1.52 M x 0.76 M)	60 IN. x 30 IN. (1.52 M x 0.76 M)
PLATFORM ROTATION	180°	180°
STOWED LENGTH	15 FT 6 IN. (4.72 M)	17 FT 3 IN. (5.26 M)
STOWED HEIGHT	7 FT 7 IN. (2.31 M)	7 FT 7 IN. (2.31 M)
WIDTH	7 FT 2 IN. (2.18 M)	7 FT 4 IN. (2.23 M)
WHEELBASE	6 FT 3 IN. (1.91 M)	6 FT 3 IN. (1.91 M)
GROUND CLEARANCE	12 IN. (0.31 M)	12 IN. (0.31 M)
GROSS WEIGHT	11,600 LBS (5.261 KG)	13,800 LBS (6.169 KG)
OUTSIDE TURNING RADIUS	16 FT (4.87 M)	16 FT (4.87 M)
INSIDE TURNING RADIUS	7 FT 3 IN. (2.21 M)	7 FT 3 IN. (2.21 M)
GRADEABILITY (ON HARD SURFACE)	15 ° (27%)	15 ° (27%)
TRAVEL SPEED		
BOOMS STOWED	5 MPH (8 KPH)	5 MPH (8 KPH)
BOOMS ELEVATED	0.5 MPH (0.8 KPH)	0.5 MPH (0.8 KPH)
ENGINE OPTIONS		
GAS/ DUAL FUEL		
ONAN	24 HP, 3600 RPM	24 HP, 3600 RPM
WISCONSIN	- - -	30 HP, 3600 RPM
DIESEL		
DEUTZ	- - -	35 HP, 3000 RPM
LOMBARDINI	23 HP, 3000 RPM	23 HP, 3000 RPM
PERKINS	23.5 HP, 3600 RPM	23.5 HP, 3600 RPM
ELECTRICAL POWER SOURCE	12 VOLT BATTERY	12 VOLT BATTERY

MACHINE SPECIFICATIONS (CONTINUED)

	AT30C	AT40C
PUMP PRESSURE	2800 PSI (193 BARS)	2800 PSI (193 BARS)
HYDROSTATIC PUMP CHARGE PRESSURE . . .	70 TO 150 PSI (5 TO 10 BARS)	70 TO 150 PSI (5 TO 10 BARS)
DRIVE SYSTEM PRESSURE		
AT REST	200 PSI (14 BARS)	200 PSI (14 BARS)
MOVING	200 TO 4300 PSI	200 TO 4300 PSI
DRIVE CROSS PORT RELIEF VALVE SETTING .	4300 PSI (297 BARS)	4300 PSI (297 BARS)
MAXIMUM LIFT SYSTEM PRESSURE	2800 PSI (193 BARS)	2800 PSI (193 BARS)
LIFT FUNCTION RELIEF VALVE SETTING	2800 PSI	2800 PSI
STEERING RELIEF VALVE SETTING	2800 PSI	2800 PSI
DRIVE CONTROL PRESSURE		
AT VALVE AND BRAKE	525 PSI (36 BARS)	525 PSI (36 BARS)
AT STROKE CYLINDER	80 TO 525 PSI	80 TO 525 PSI
DRIVE CONTROL RELIEF VALVE SETTING	650 PSI (45 BARS)	650 PSI (45 BARS)
MAX. DRIVE PUMP INLET VACUUM UNDER NORMAL CONDITIONS	5 IN. HG	5 IN. HG
HYDRAULIC FLUID CAPACITY		
TANK	15 GAL. (61 L)	15 GAL. (61 L)
SYSTEM (APPROX.)	20 GAL. (76 L)	20 GAL. (76 L)
FUEL CAPACITY		
30 HP WISCONSIN OR DEUTZ DIESEL . . .	- - -	10 GAL (39 L)
OTHER GAS OR DIESEL	13.5 GAL. (51 L)	13.5 GAL. (51 L)
PROPANE	35 LBS. (15.9 KG)	35 LBS. (15.9 KG)
TIRES	14/ 35-16.5 LT	15/ 38.5-16.5 LT
TIRE PRESSURE		
STANDARD PNEUMATIC TIRES	50 PSI (3.4 BAR)	55 PSI (3.8 BAR)
OPTIONAL LIQUID BALLASTED TIRES . . .	50 PSI	55 PSI
WHEEL LUG NUT TORQUE	120 FT LBS (160 NM)	120 FT LBS (160 NM)
AXLE MOUNTING BLOCK BOLT TORQUE	285 FT LBS (381 NM)	285 FT LBS (381 NM)
SWING BEARING BOLT TORQUE	220 FT LBS (294 NM)	220 FT LBS (294 NM)
		(SN 5088 AND UP)
		130 FT LBS (174 NM)
		(SN 5000 TO 5087)
SWING DRIVE MOUNTING BOLT TORQUE	80 FT LBS (107 NM)	80 FT LBS (107 NM)
COIL RESISTANCE FOR LIFT, DRIVE, BRAKE, STEERING AND LOW SPEED DRIVE	AT LEAST 6 OHMS	AT LEAST 6 OHMS

MACHINE COMPONENT LOCATOR

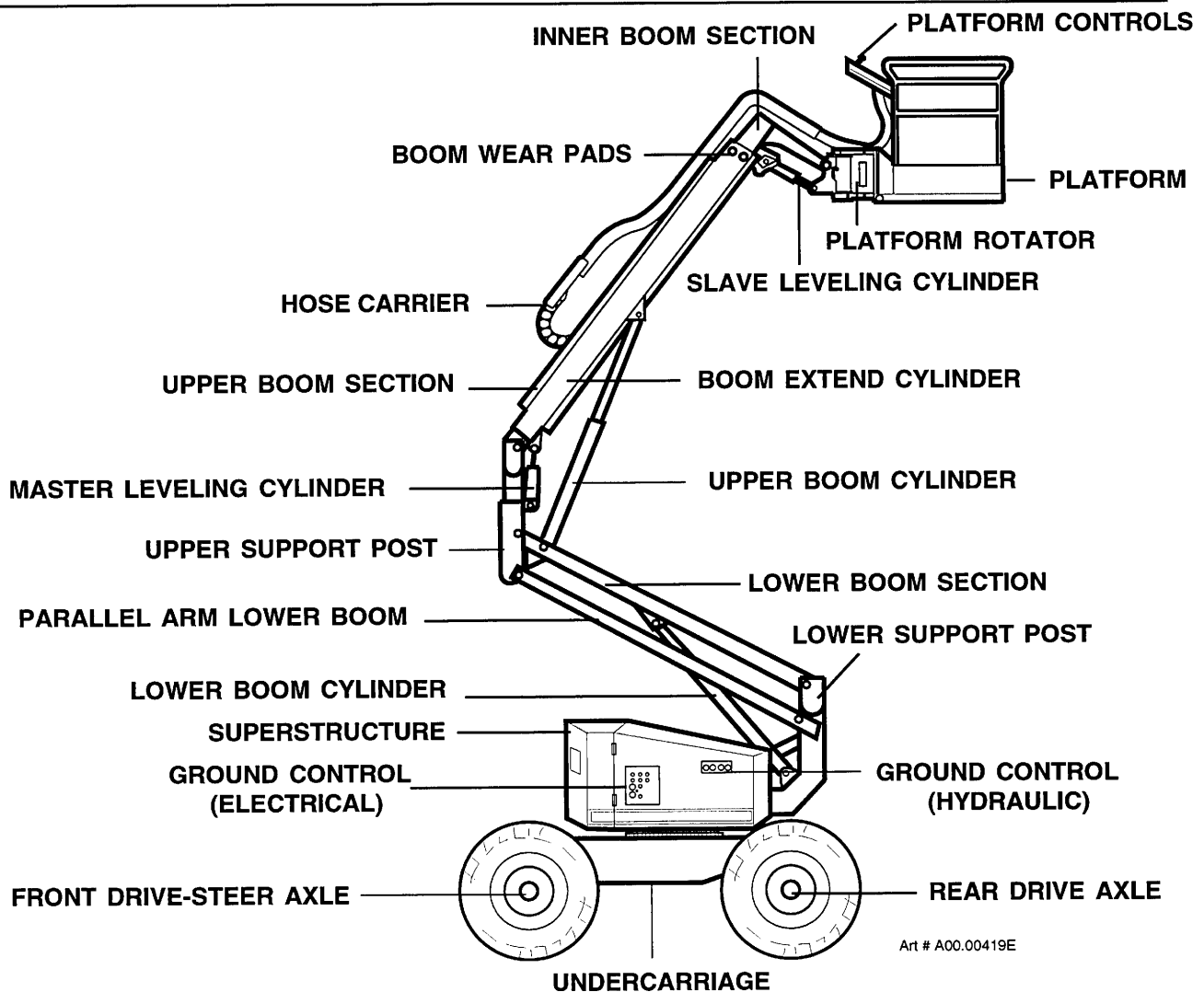
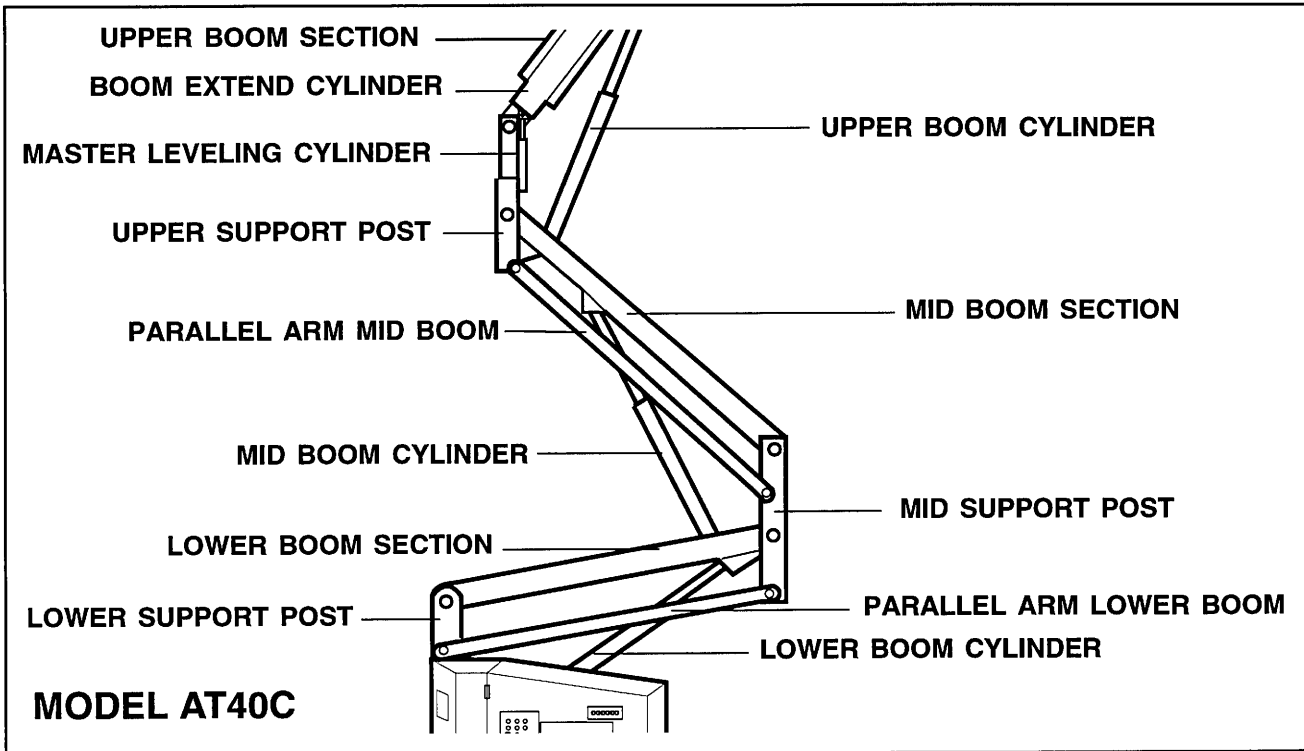

Art # A00.00419E

UNDERCARRIAGE COMPONENT LOCATOR

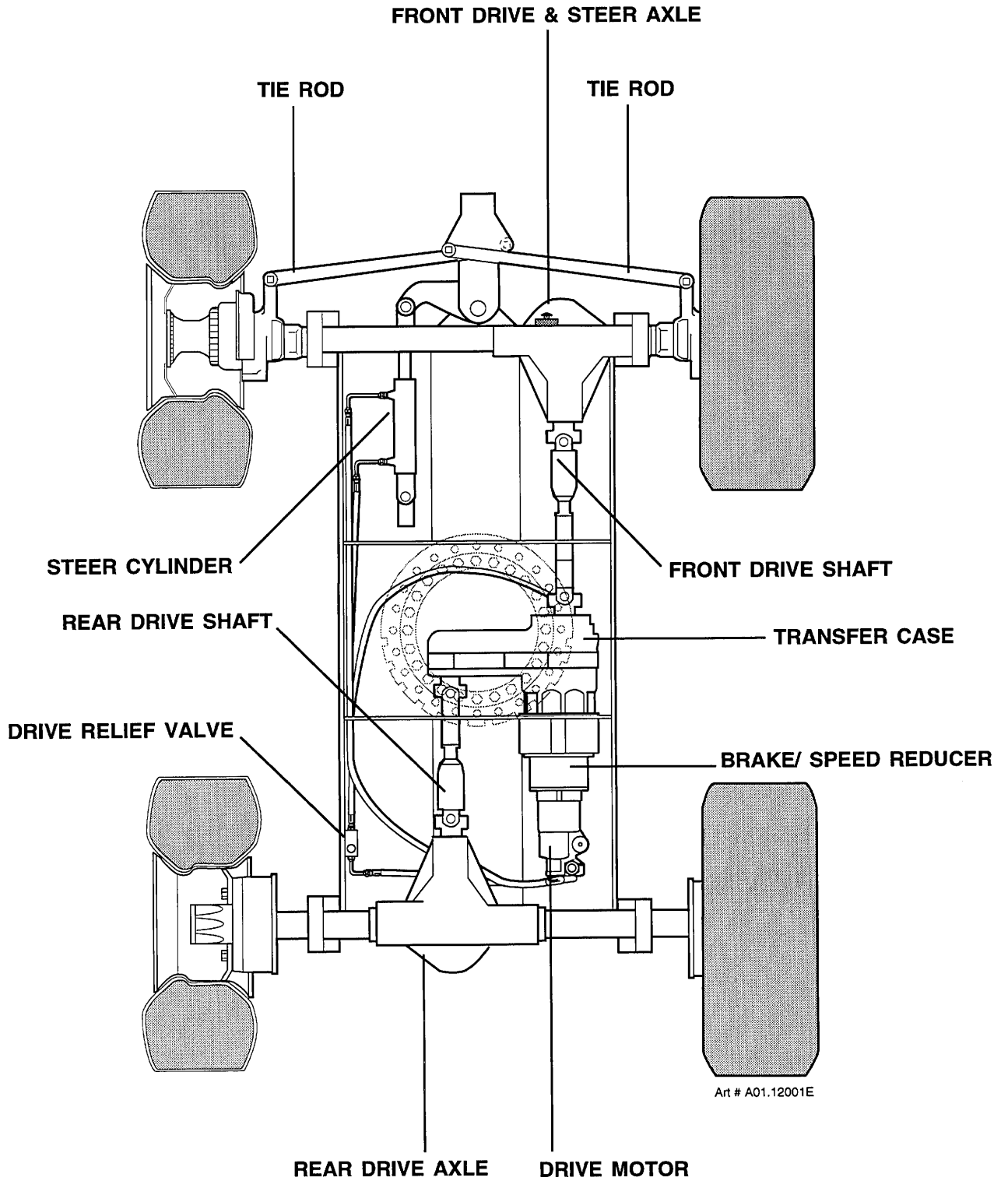

SUPERSTRUCTURE COMPONENT LOCATOR (MODEL AT40C SHOWN)

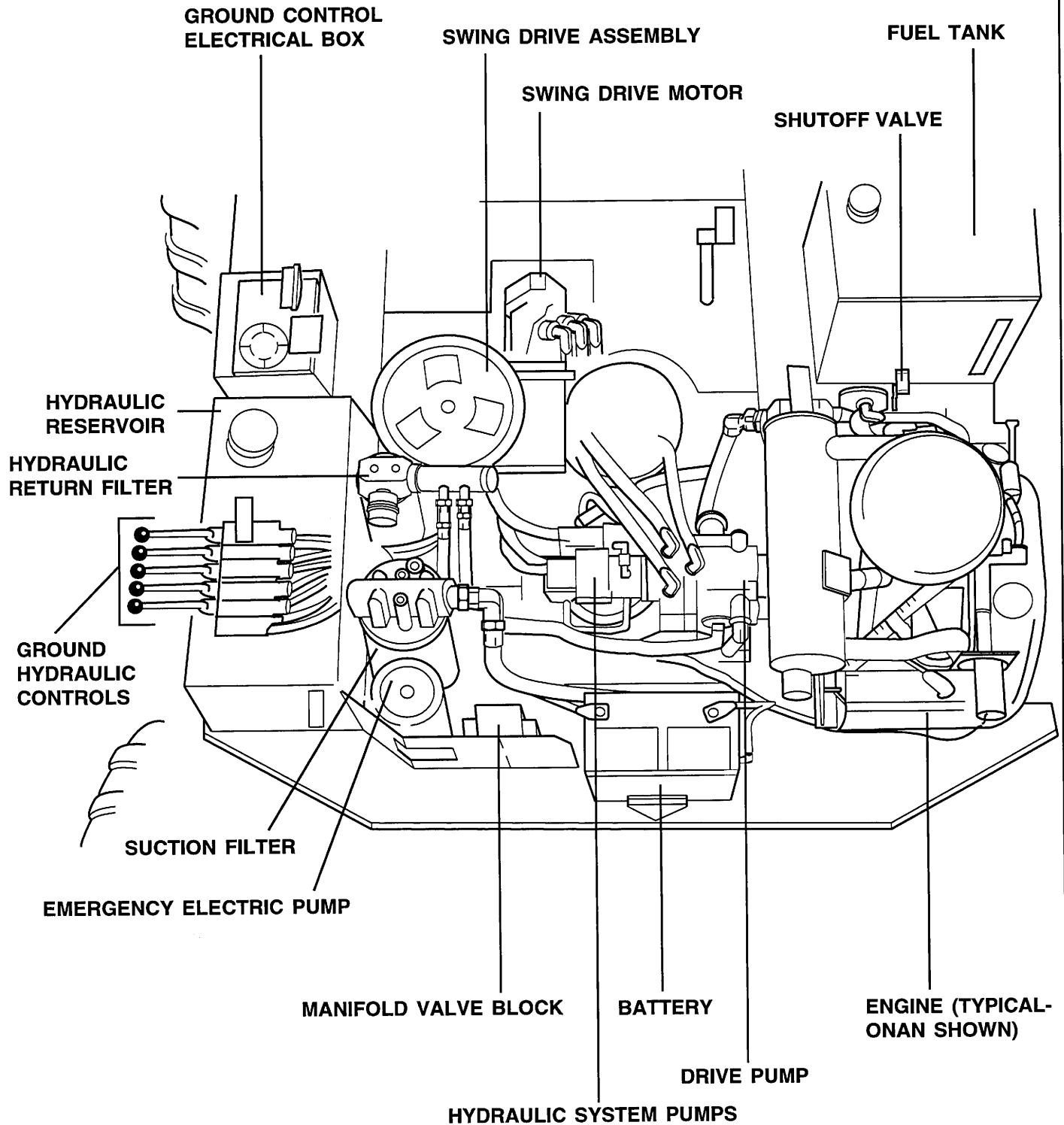

PLATFORM COMPONENT LOCATOR (MODEL AT40C SHOWN)

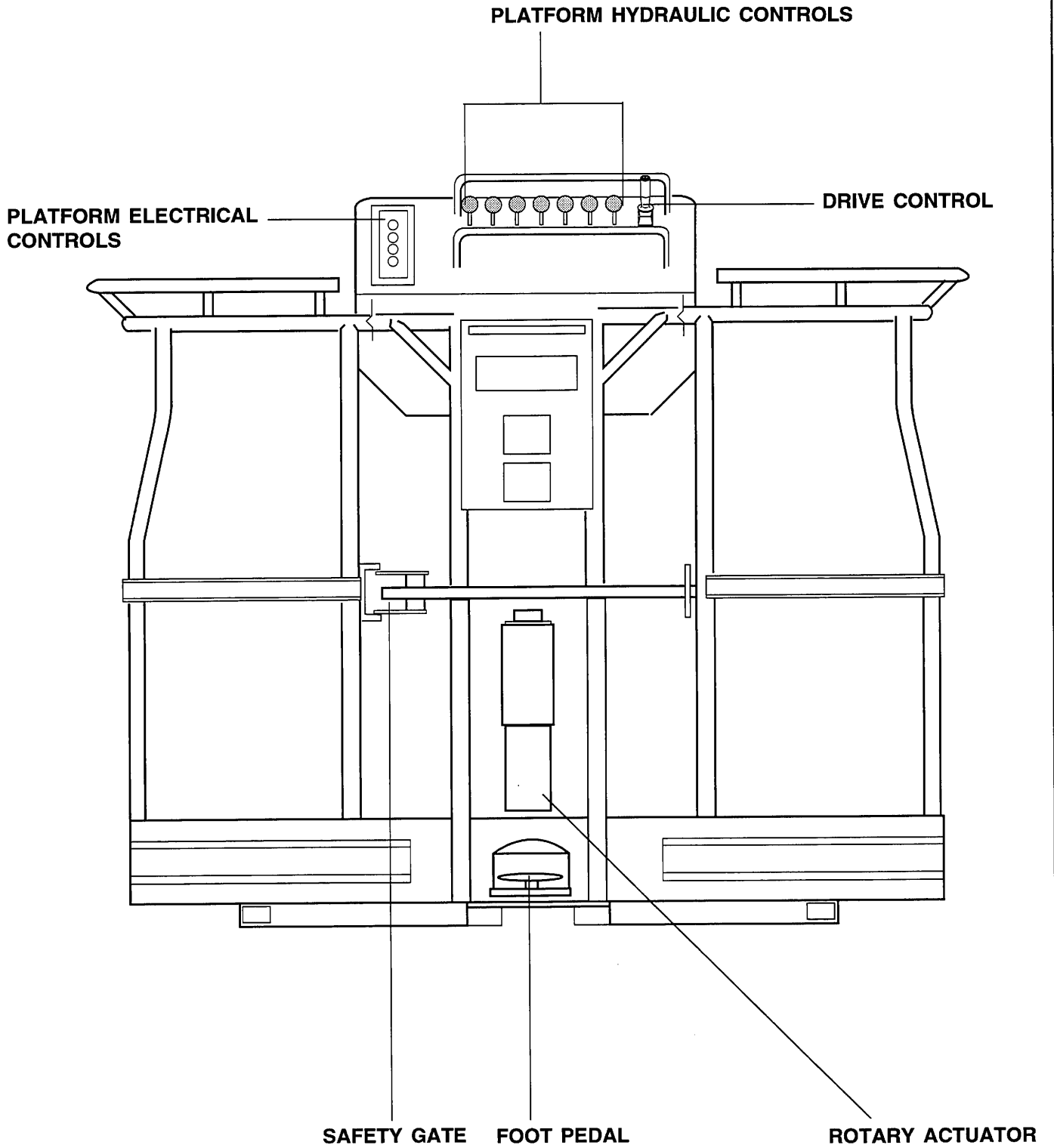

LUBRICATION DIAGRAM

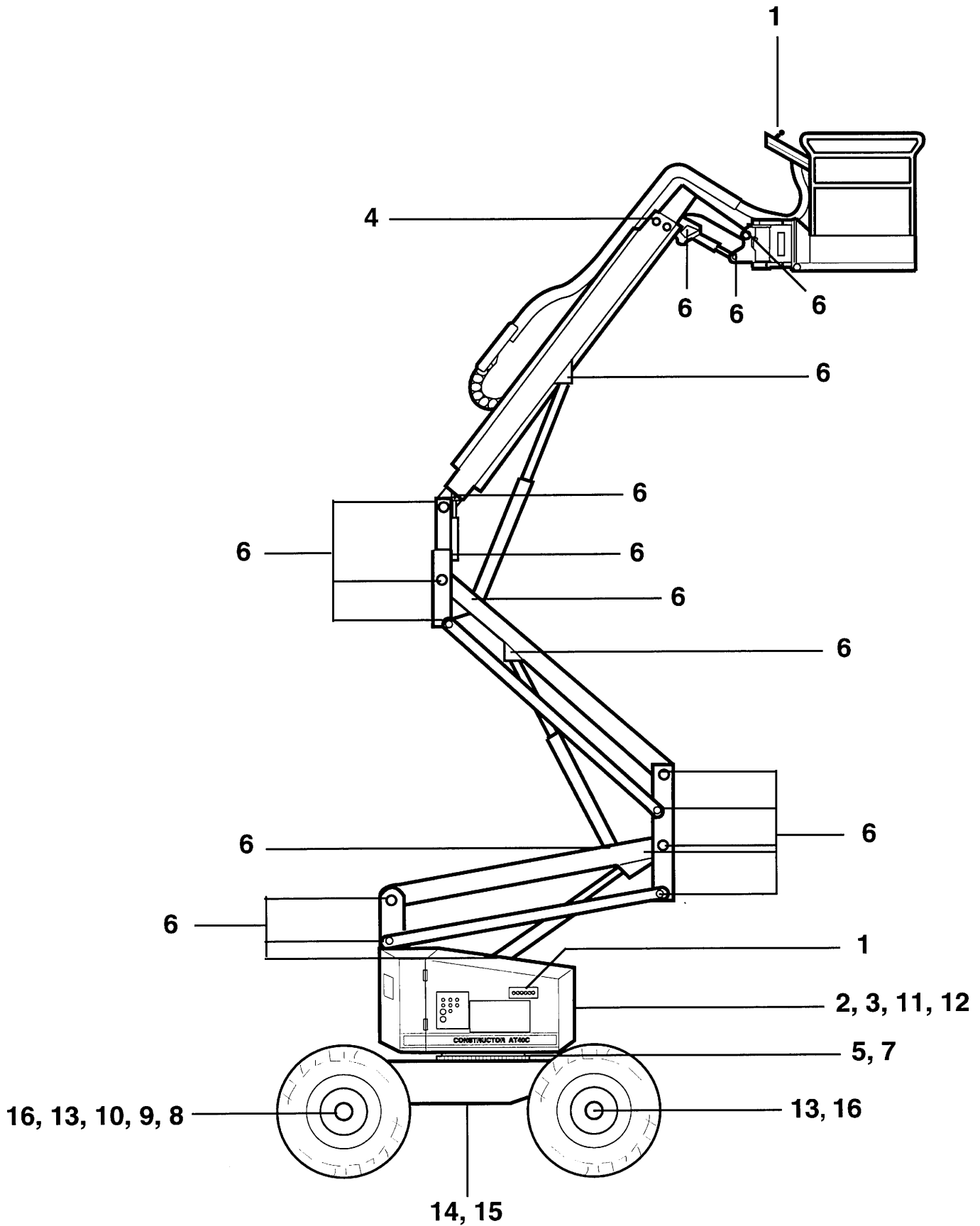

LUBRICATION CHART

ITEM NO.	DESCRIPTION	SPECIFICATION (QUANTITY)	FREQUENCY OF LUBRICATION
1	CONTROL VALVE PIVOT PIN HANDLES	WD 40 SPRAY	MONTHLY OR EVERY 100 HRS.*
2	HYDRAULIC RESERVOIR	MOBIL DTE-15 TO FULL MARK W/ CYLINDERS RETRACTED	CHECK DAILY, ANALYZE EVERY 6 MONTHS, CHANGE YEARLY.
3	HYDRAULIC FILTERS	FILTER ELEMENTS	CHANGE EVERY 6 MONTHS.
4	BOOM WEAR PADS	DRY SILICONE LUBRICANT	MONTHLY OR EVERY 100 HRS.*
5	SWING BEARING	LITHIUM N.L.G.I. #2 EP (PURGE OLD GREASE)	MONTHLY OR EVERY 100 HRS.*
6	PIVOT PINS	LITHIUM N.L.G.I. #2 EP (PURGE OLD GREASE)	MONTHLY OR EVERY 100 HRS.*
7	SWING BEARING GEAR TEETH	LITHIUM N.L.G.I. #2 EP GREASE OR DRI-LUBE	EVERY 6 MONTHS OR 500 HRS.*
8	STEERING SPINDLES	LITHIUM N.L.G.I. #2 EP (PURGE OLD GREASE)	MONTHLY OR EVERY 100 HRS.*
9	STEERING HUB AND U-JOINTS	LITHIUM N.L.G.I. #2 EP CLEAN AND REPACK	MONTHLY OR EVERY 100 HRS.*
10	STEERING LINKAGE	LITHIUM N.L.G.I. #2 EP (PURGE OLD GREASE)	MONTHLY OR EVERY 100 HRS.*
11	SWING DRIVE GEAR BOX TOP BEARING	LITHIUM N.L.G.I. #2 EP (PURGE OLD GREASE)	CHECK BI-MONTHLY OR EVERY 200 HRS.* CHANGE EVERY 2 YEARS OR 2,000 HRS.*
12	SWING DRIVE GEAR BOX	N.L.G.I. #00 EP OR SAE EP 140 WT. OIL (TO FILL PLUG)	CHECK BI-MONTHLY OR EVERY 200 HRS.* CHANGE EVERY 2 YEARS OR 2,000 HRS.*
13	DIFFERENTIAL	EP-90W (TO FILL PLUG)	CHECK MONTHLY, CHANGE YEARLY.
14	SPEED REDUCER	EP-90W (TO FILL PLUG)	CHECK MONTHLY, CHANGE YEARLY.
15	TRANSFER CASE	AUTO TRANSMISSION FLUID TYPE F (TO FILL PLUG)	CHECK MONTHLY, CHANGE YEARLY.
16	DRIVE SHAFT U-JOINTS AND SLIP JOINTS	LITHIUM N.L.G.I. #2 EP GREASE	CHANGE MONTHLY OR EVERY 100 HRS.*

* WHICHEVER OCCURS FIRST.

EMERGENCY PROCEDURES



IF THE ENGINE FAILS WHILE THE OPERATOR'S PLATFORM IS RAISED OR EXTENDED, DO NOT ATTEMPT TO CLIMB DOWN THE BOOM ASSEMBLY. SERIOUS INJURY MAY RESULT.

EMERGENCY ELECTRIC PUMP

Each CONSTRUCTOR has an emergency pump which can be operated from the operator's platform or at the ground control station. To safely return the platform to the ground position, turn and hold the emergency pump switch to the "ON" position and operate the boom control levers to lower and retract the boom sections.

Always use caution in selecting the correct valve lever to bring the operator to safety.

EMERGENCY MOVEMENT

The emergency pump will not provide control or operation of the drive or steering functions. Should it be necessary to move or steer the unit, you must do the following:

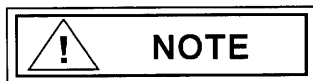

Unit must be blocked or attached to the tow vehicle prior to the following steps.

WITHOUT OPTIONAL TOWING PACKAGE:

Remove drive shaft from front and rear axles. On front (steer) axle, turn steering wheel hub release knobs in center of wheel hubs to "FREE" position. Remove steering cylinder rod end pin from steering linkage, allowing steering wheels to track tow vehicle.

WITH OPTIONAL TOWING PACKAGE:

Disengage front (steer) axle drive hubs by turning knobs in center of hubs. Pull lever provided to disengage rear drive axle, and pull control valve to allow front (steering) wheels to track tow vehicle.

EMERGENCY LOWERING

SITUATION: Platform elevated, operator not incapacitated, but unit will not respond to platform controls.



DO NOT TRY TO CLIMB DOWN THE BOOM.

HAVE AN EXPERIENCED OPERATOR USE THE EMERGENCY PUMP TO SAFELY LOWER THE PLATFORM.

POSSIBLE CONDITION:

- One or more functions not operating correctly.
- Unit movement from unselected control lever.
- Unit function will not stop unless power is switched off.

CORRECTIVE ACTION:

1. Remove foot from foot pedal.
2. Evaluate the nature of the failure. Return to the ground if possible. If the condition will not allow you to return to the ground, contact an experienced operator to lower the machine using the emergency pump and lowering procedure.
3. **Report the incident to your supervisor immediately.**

SITUATION: Unit elevated with operator incapacitated at platform controls.



DANGER!!! DO NOT TOUCH UNIT!!!

DETERMINE THE CAUSE OF THE PROBLEM BEFORE YOU TOUCH THE MACHINE.

CORRECTIVE ACTION:

1. Have someone summon first aid or rescue squad.
2. Attempt to talk to operator before taking any rescue measures.
3. **Check to see if operator is in a pinned position before attempting emergency lowering procedure.**
4. After establishing that the machine is not in contact with live power lines, lower the platform using the emergency lowering procedure.
5. Render first aid to the operator.

SITUATION: Platform in contact with live power lines, operator incapacitated.



DANGER!!! DO NOT TOUCH UNIT!!!

CORRECTIVE ACTION:

1. Contact authorized personnel to disconnect power supply touching unit.
2. Have someone summon first aid or rescue squad.
3. If operator is unconscious, check to see if he is in a pinned position.
4. **AFTER POWER IS CUT, use the emergency lowering procedure to bring platform with operator to a safe location to render first aid.**



Any incident involving personal injury must be immediately reported to the local Simon Aerials Distributorship as well as to Simon Aerials Inc.

HYDRAULIC FLUID

HANDLING PRECAUTIONS



PERSONS IN REGULAR CONTACT WITH MINERAL OILS NEED TO BE AWARE OF THE IMPORTANCE OF THOROUGH HYGIENE, AND THE PROPER METHODS FOR HANDLING MINERAL OILS IN ORDER TO AVOID POTENTIAL HAZARDS TO HEALTH.

If mineral-based hydraulic fluid is **SPLASHED INTO THE EYES**, it must be **WASHED OUT THOROUGHLY** using abundant quantities of water. If irritation persists, medical advice should be sought.

Mineral oils act as solvents on the natural oils in the skin. **FREQUENT AND PROLONGED SKIN CONTACT CAN CAUSE DERMATITIS OR SEVERE IRRITATION.** Mineral-based hydraulic fluids normally present no health hazard when used intelligently. Protective clothing and proper washing facilities should be provided or be accessible.



HYDRAULIC FLUID UNDER PRESSURE CAN PENETRATE AND BURN THE SKIN, DAMAGE EYES, AND MAY CAUSE SERIOUS INJURY, BLINDNESS AND EVEN DEATH.

FLUID LEAKS UNDER PRESSURE MAY NOT ALWAYS BE VISIBLE.

IF MINERAL-BASED HYDRAULIC FLUID HAS PENETRATED THE SKIN, IT MUST BE SURGICALLY REMOVED, BY A DOCTOR FAMILIAR WITH THIS TYPE OF INJURY, WITHIN A FEW HOURS.

FLUID RECOMMENDATIONS

We strongly recommend the use of **MOBIL DTE-15 HYDRAULIC FLUID**. An **EXACT** substitute can be used if absolutely necessary. Mineral-based hydraulic fluids produced by different companies will **USUALLY** mix with each other satisfactorily, but this **IS NOT RECOMMENDED**. When in doubt, consult your supplier.

MOBIL DTE-15 has proven to be suitable for use in all climates. For continued operation in temperatures below **32° F (0° C)**, the use of **MOBIL DTE-13** or **DTE-11 FLUID** may prove satisfactory.

For operation in tropical climates, the use of **MOBIL DTE-16** is allowable.

FLUID CONTAMINATION CHECKS

Use the following as a guide to determine when analysis of the hydraulic fluid is necessary.

- Any time the engine driven hydraulic pump is replaced.
- If fluid discoloration is noticed in the hydraulic reservoir sight tube.
- If, after the first 50 hours of operation, the hydraulic filter elements are plugged.
- Any time the hydraulic filter elements show signs of metal content.
- If operator control valve spools have continuous sticking problems which are not corrected by lubrication.
- Once a year, under normal operating conditions.
- Every 6 months, in extremely dusty or dirty operating conditions.

The hydraulic fluid analysis must be done by a qualified laboratory. To insure that you receive accurate recommendations about the fluid being analyzed, always provide the following information with the test sample.

- Type of hydraulic fluid. (See Lubrication Chart)
- Model and serial number of unit from which sample was taken.
- Purpose of analysis: i.e. pump failure, discoloration, etc.
- Type of analysis: i.e. complete to show additive breakdown, acid buildup, viscosity, type and percent of contaminants. Comparison to new fluid and recommendations.

Comply with contamination analysis and recommendations to achieve a clean, contamination free hydraulic system.

Following the above guide will prevent premature failure of pumps, cylinder seals and drive motors, and will prevent unnecessary down time.

If system flushing and replacement of fluid is recommended, refer to the following flushing procedure.

SYSTEM FLUSHING PROCEDURE

With BOOMS DOWN AND FULLY RETRACTED (in stowed position), drain hydraulic fluid from main hydraulic tank into a clean, empty container. This can be done with an oil filter cart so the fluid may be reused if analysis is good.

When the hydraulic tank is empty, remove suction hoses between tank and pump. Remove hoses between pump and main valve bank. Flush the hoses. Remove hydraulic fluid filter, and flush the filter body and attaching hoses. Discard old filter element and replace. Drain drive circuit hoses from pump to motor. Drain pump and motor cases. Reconnect all DRIVE CIRCUIT hoses.

With hoses removed from the hydraulic tank, open tank bottom drain and flush out the tank. When this is completed, all the hoses removed in the previous steps should be properly reinstalled EXCEPT the system return line to tank. This hose should be lengthened to drain into the container used for the reservoir fluid.

If the hydraulic fluid removed from the reservoir is good, it can now be pumped (through a filter cart) back into the tank. If fluid is not usable, fill hydraulic tank with filtered, fresh hydraulic fluid (refer to Lubrication Chart).

Make sure the suction line valves are opened to allow fluid to flow to the hydraulic pump. Loosen hose fittings at pump to allow pump to flood with hydraulic fluid, then tighten pump fittings. Fill drive pump case with filtered oil.

Turn key switch "ON". Start engine. Turn power switch clockwise to engage pump.

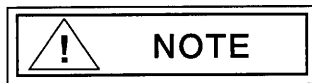
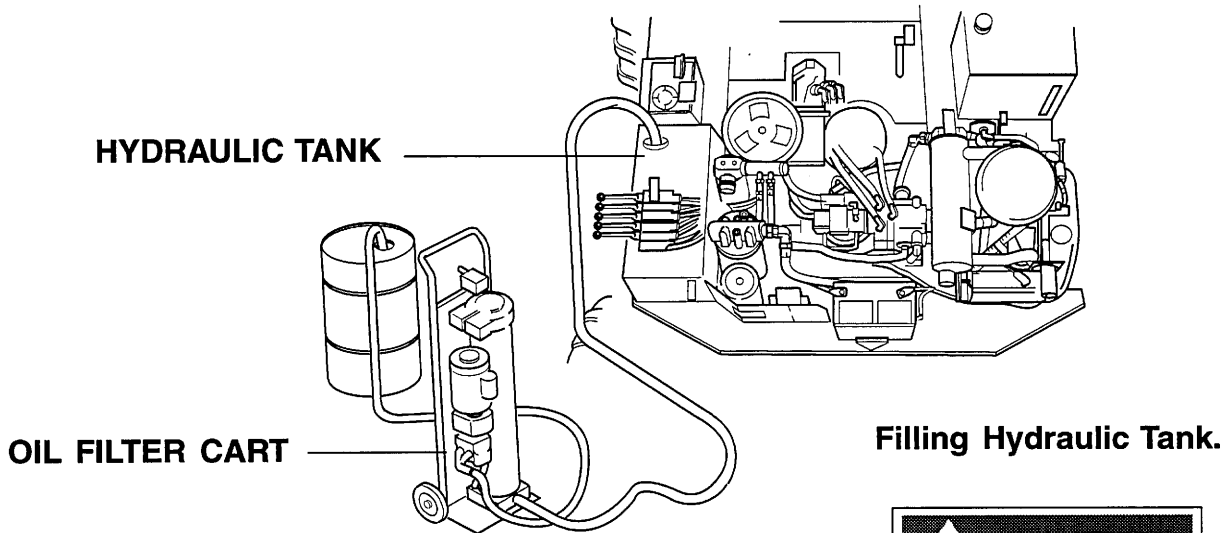

Use care when starting and running the engine as hydraulic fluid is now being returned to container provided.



SHUT ENGINE DOWN if charge pump pressure **DOES NOT REACH 150 PSI WITHIN 15 SECONDS**. Check for proper priming. Ensure that pump case and lines to pump are filled with fluid, and that relief valve in pump is working properly.

Once charge pump pressure reaches approximately 150 PSI, let the engine run at low idle for five minutes. Then, watch charge pump pressure while operating each hydraulic cylinder function to its maximum limits. This will remove old fluid from the rest of the hydraulic system.

Monitor the hydraulic tank fluid level when cycling the unit functions, adding fluid as necessary to replace that being discharged to container at system return line. This fluid may be returned to the reservoir through a filter cart, if good.

Three cycles of ALL hydraulic cylinder functions should remove enough old hydraulic fluid from the system.

Flush the drive motors with the **WHEELS BLOCKED OFF OF THE GROUND AND THE ENGINE OFF**. Remove one of the two hoses from the drive motor. Direct that hose and another "jumper" hose into a pan to catch the return fluid. Start the engine and operate only long enough to purge the fluid from both hoses. Reconnect the hose to the drive motor.

When the above procedures have been completed, reconnect all hoses including system return hose to tank. Fill the hydraulic reservoir to full mark on sight gauge.

Operate all functions to their full extreme positions to insure proper operation.

Check for leaks and correct as necessary. Unit is now ready to be placed back in operation.

HYDRAULIC SYSTEM

Following is a description of the major components of the CONSTRUCTOR hydraulic system.

PUMPS

The following engine driven hydraulic pumps are used to operate the various machine functions:

A. DRIVE PUMP

This hydrostatic pump is a variable displacement axial piston pump connected in a closed loop circuit to a two speed axial piston motor. This pump is driven by the engine and provides hydraulic fluid flow to the drive motor

when the pump control shaft is moved in one direction or the other. The pump control shaft determines the direction of fluid flow to the motor, allowing forward or reverse travel.

The pump also contains a built in charge pump. The charge pump provides hydraulic fluid to the pump/motor closed loop circuit, in order to replenish any fluid loss due to internal leakage and to prevent pump cavitation.

Maximum drive pump pressure is limited by a cross port relief valve (refer to "Machine Specifications"). Since the pump/motor circuit is a closed loop, either side can be pressurized, depending on travel direction. The cross port relief valve protects either drive hose as required.

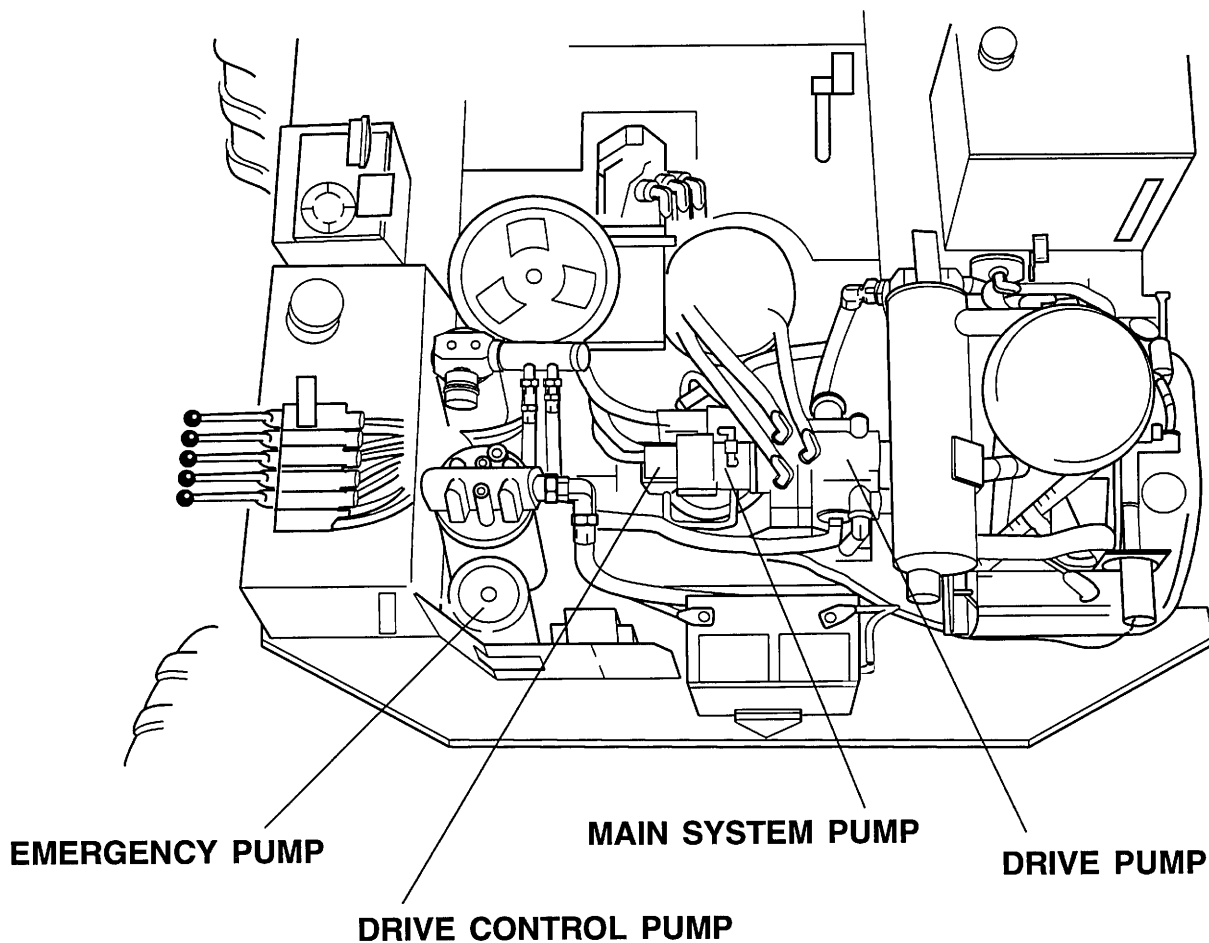

Hydraulic Pump Locations (AT40C shown).

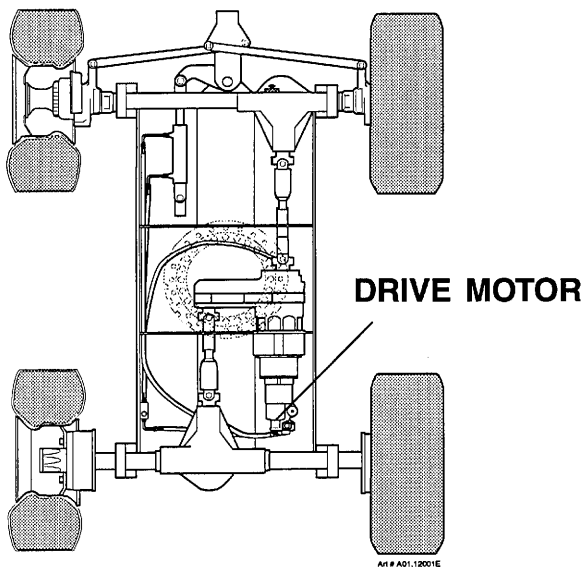

Drive Motor Location.

B. DRIVE MOTOR

A two speed axial piston motor is mounted to the drive train located in the undercarriage of the machine. This motor is driven by hydraulic fluid flow provided by the drive pump. The direction of rotation and speed of this motor depend on the flow from the drive pump. Drive system pressure is dependent on the load on the machine

C. MAIN SYSTEM AND DRIVE CONTROL TANDEM PUMP

This tandem pump, mounted on the end of the drive pump, consists of two gear pumps coupled end to end.

The larger pump provides fluid to operate all the machine functions except "DRIVE" and the drive controller. This pump supplies the system manifold block to operate the functions as selected by the operator, when either the ground control power switch or platform foot switch are activated.

The smaller pump provides fluid to operate the drive controller and the driveline brake, mounted between the drive motor and transfer case. This pump also supplies fluid to the

system manifold block. When the platform foot switch is activated, fluid is directed to the drive controller and to the spring applied, hydraulically released driveline brake.

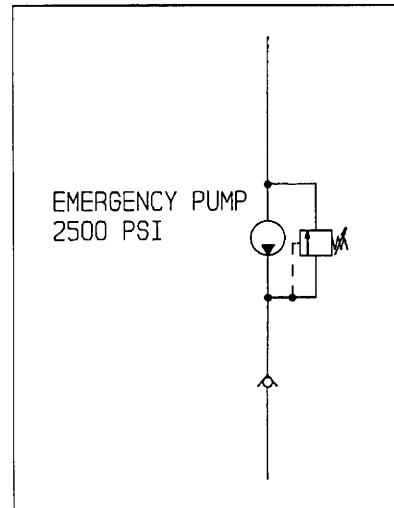

Emergency Pump Hydraulic Schematic.

D. EMERGENCY PUMP

This is a 12 volt electric pump, used to provide fluid flow to operate all boom functions in case of engine failure. The pump has a built in relief valve and is connected to the ground control valve bank. To operate the emergency pump, turn the emergency pump switch clockwise and choose the desired boom function. This system can be operated from either the ground or platform control station.

The emergency pump is meant to be used only under emergency conditions, to safely lower the operator's platform to the ground.

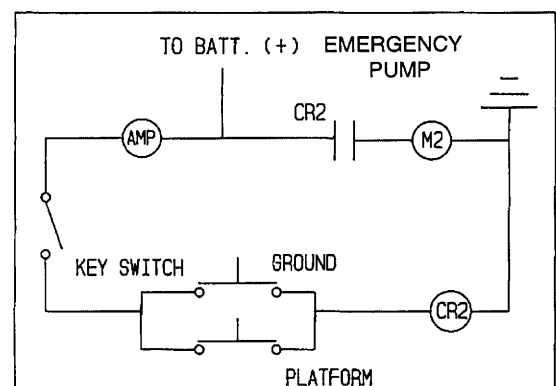

Emergency Pump Electrical Schematic.

MANIFOLD

The hydraulic system manifold block, located on the hydraulic tank subassembly, controls hydraulic fluid flow to operate the lift, drive and brake functions of the machine.

Hydraulic fluid flow from the engine mounted tandem pump is directed to the manifold and dispersed to the valves controlling machine functions through ports identified by letters or numbers stamped into the manifold block. Refer to "Machine Specifications" for system pressures.

Port marked "FP". Hydraulic fluid from the larger gear pump enters at this port. Fluid flows through the manifold, **steering control valves** and **lift power switch control solenoid** (normally open), back to the reservoir. When a lift function is selected, the lift power switch solenoid valve closes, causing fluid to leave the manifold by the **port marked "F"**, where it enters the ground control valve bank to operate the selected boom function.

Port marked "DP". Hydraulic fluid from the smaller gear pump enters at this port. Fluid flows through the **drive power switch control solenoid valve** (normally open) back to the reservoir. When the "DRIVE" function is selected (from the operator's platform only), the drive solenoid valve closes, causing fluid to flow to **port "D"**, then up the boom to the operator's drive controller valve.

Ports marked "SA" and "SB". These ports direct fluid flow from the electrically controlled **steering control valves** mounted on the manifold block to the double-acting steer cylinder end ports to steer the wheels left or right.

Port marked "LD". When a boom is raised, the **low speed solenoid** opens this port to direct fluid flow from the actuator cylinder (stroke cylinder) center port back to the reservoir, limiting cylinder stroke and drive pump output.

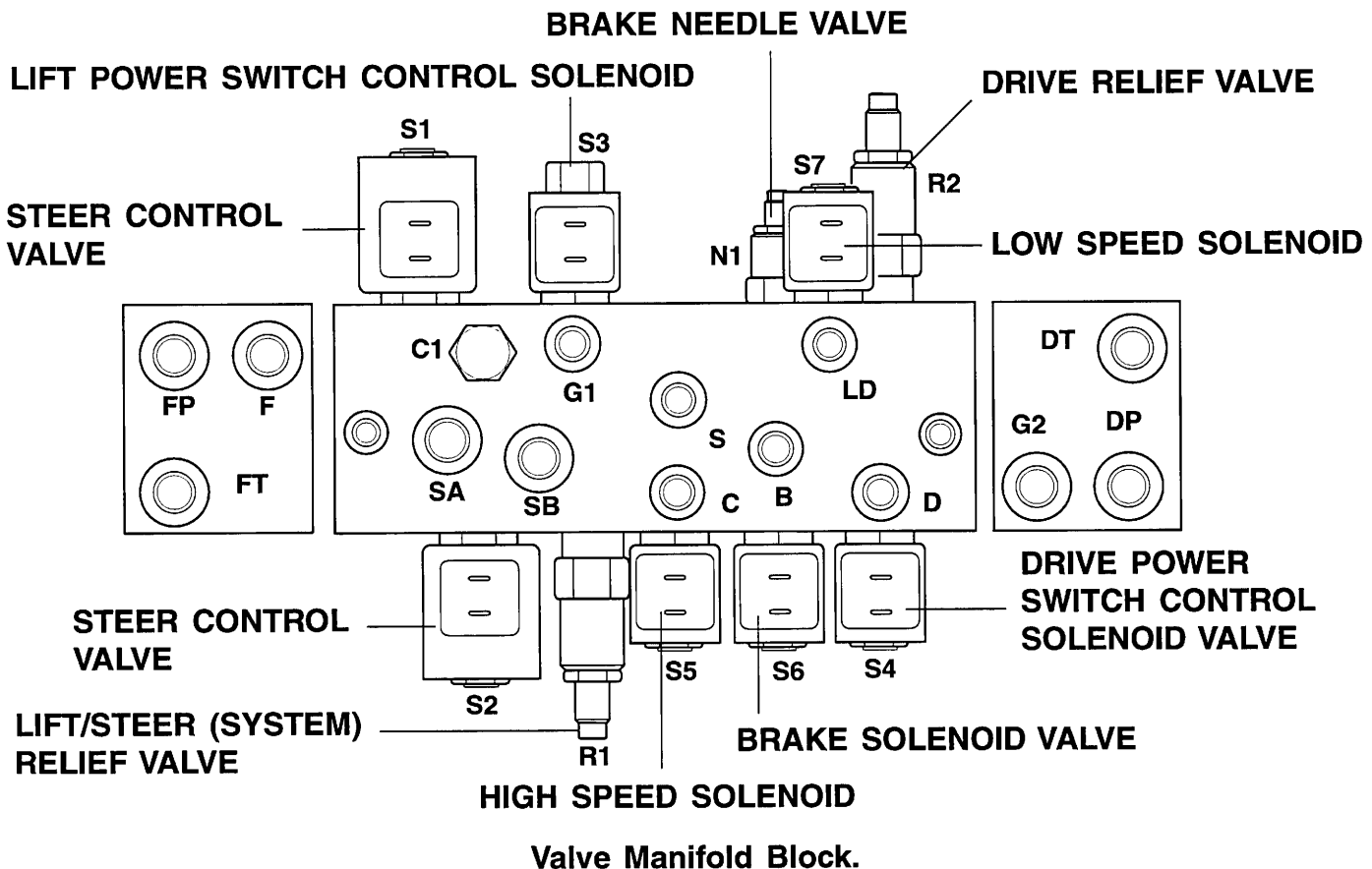

Ports marked "FT" and "DT". There is one "T" port located at each end of the manifold to allow fluid flow back to the hydraulic fluid reservoir.

Ports marked "G1" and "G2". These ports are for use with gauges during manifold relief adjustments and remain plugged during normal operation.

Ports marked "C" and "S". When the drive speed knob on the platform control panel is switched to "HIGH", the **high speed solenoid** actuates, directing fluid flow from the hydrostatic charge pump to the drive motor, shifting the two speed motor to its high speed mode.

Port marked "C1". This port contains a check valve which isolates emergency pump flow from main system pump flow. Emergency pump flow is directed to the ground and platform valve banks rather than into the manifold.

The **Lift function and steering relief valve** acts to regulate pressure in the lift circuit.

The **Brake solenoid valve** controls fluid flow to the driveline brake. Whenever the drive function is selected, this valve opens to release the brake.

The **Brake needle valve** is an adjustable needle valve in the brake line. It allows a free flow of fluid to release the driveline brake and controls flow when the brake is engaged to prevent sudden stops. Fluid leaves the manifold through **Port "B"** for the brake function.

The **Drive control relief valve** acts to prevent component damage due to excessive pressure in the drive/ brake control system.

Ports other than those listed above are not in use.

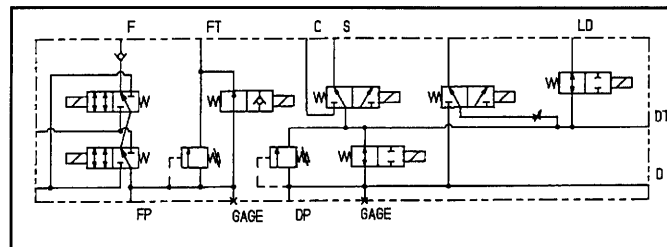

Manifold Valve Block Hydraulic Schematic.

MANIFOLD MAINTENANCE

Operate the engine, and check the manifold block and solenoid securing bolts for tightness. Check the security and condition of hoses, cables and wire connections.

MANIFOLD ROUTINE SERVICE CHECKS

Refer to "Machine Specifications" to determine coil resistance values.

1. Lift power switch control solenoid.

Turn on main power key switch. Use a Volt-Ohmmeter to check for power at lift power switch control solenoid coil when ground power switch is turned on. With power supplied to coil, valve will operate unless coil is open. Check for open coil with an Ohmmeter across the coil leads. The problem, if electrical, may be caused by a bad switch, or by a loose wire in the ground control cabinet or the platform foot pedal switch.

2. Drive power switch control solenoid valve.

Turn on main power key switch. Turn ground/platform switch to "PLATFORM" position. Connect a Volt-Ohmmeter between wire "MN3" and wire "X3" of drive solenoid. Turn the platform ignition switch to the "ON" position, and press foot pedal on platform. Power should be available at wire "MN3" of drive solenoid. Check valve coil with an ohmmeter.

If drive solenoid valve sticks, it may have to be removed from the manifold to check for contamination.

3. Steering control valves and solenoids.

Turn on main power key switch. Turn ground/platform switch to "PLATFORM" position. Use a Volt-Ohmmeter to check for power at both steering valve solenoids. When the steering switch (at the drive control handle) is pushed, there should be power at one coil for "STEER RIGHT" and at the other coil for "STEER LEFT". Check the coils using an ohmmeter.

If the valve spool sticks, the valve should be removed for inspection. Clean or replace as necessary.

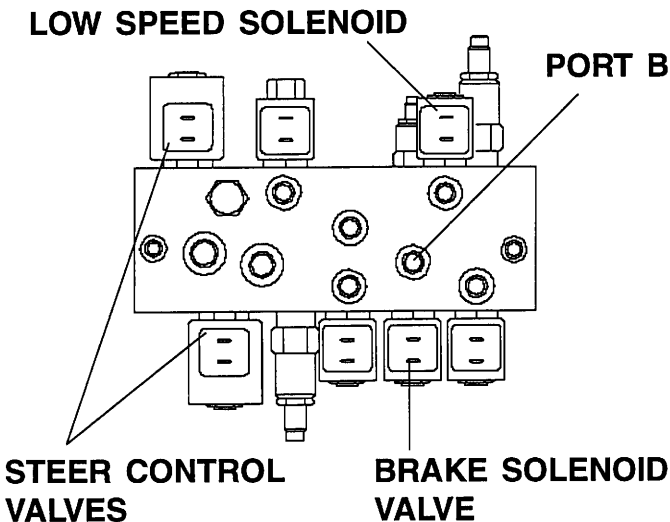

Brake Pressure Check.

4. Brake solenoid valve.

Turn on main power key switch. Turn ground/platform switch to "PLATFORM" position. Connect a Volt-Ohmmeter between wire "MN3" and wire "C3" on brake solenoid. Enter platform and start engine. Press foot pedal and slowly move drive controller forward.

The meter should indicate power to the brake solenoid valve. If necessary, install a tee and a pressure gauge in the line coming from port "B" of the manifold to see if the brake is being pressurized when the brake solenoid valve is on. The pressure gauge should read the same as the drive controller system pressure. If the meter shows voltage, but no pressure is

indicated, the solenoid valve coil may be bad. This coil should be checked using an ohmmeter.

If the brake solenoid valve sticks, it may have to be removed from the manifold to check for contamination.

Malfunction of the brake solenoid can also be caused by the neutral sense microswitch keeping the circuit open to the brake solenoid. If, however, the movement alarm sounds when trying to drive the machine, the switch is functioning and the problem is in the brake solenoid valve.

5. Low speed drive valve.

The low speed drive solenoid valve is controlled by the boom limit switches. When the booms are in the stowed position, this valve will be closed (energized). With engine running, foot pedal pressed and drive controller moved "FORWARD", a meter will indicate voltage when connected between wire "MN3" and wire "R3" at the solenoid. When a boom is raised, opening a limit switch, power to the solenoid should be cut off.

The solenoid coil should be checked using an ohmmeter. Power is supplied to the low speed drive valve through the same relays that supply the brake valve.

Possible failure points for the low speed drive valve:

- A bad boom limit switch.
- An open low speed drive solenoid coil.
- A sticking low speed drive valve.



The low speed drive solenoid valve is designed to fail in the "open" position, in order to prevent high speed travel after a component failure.

RELIEF VALVES

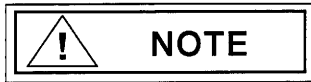

Refer to "Machine Specifications" to determine maximum system pressures for your CONSTRUCTOR.

LIFT/ STEER SYSTEM RELIEF VALVE

To check lift/ steer system relief valve setting, connect pressure gauge to pressure test fitting, located at the pump input port of the ground control valve bank. Select "GROUND" at the platform/ ground selector switch. Turn the main power switch "ON". With BOOM FULLY RETRACTED, operate the telescope lever "IN". In this situation, fluid will be directed through the system relief valve. Note pressure reading.

To adjust lift/ steer system relief valve, turn adjusting bolt on the end of the valve CLOCKWISE TO INCREASE PRESSURE, and COUNTERCLOCKWISE TO DECREASE PRESSURE.

With BOOM FULLY RETRACTED, continue to operate the telescope lever "IN" while turning adjusting bolt until proper reading is achieved. Lock the adjusting bolt.

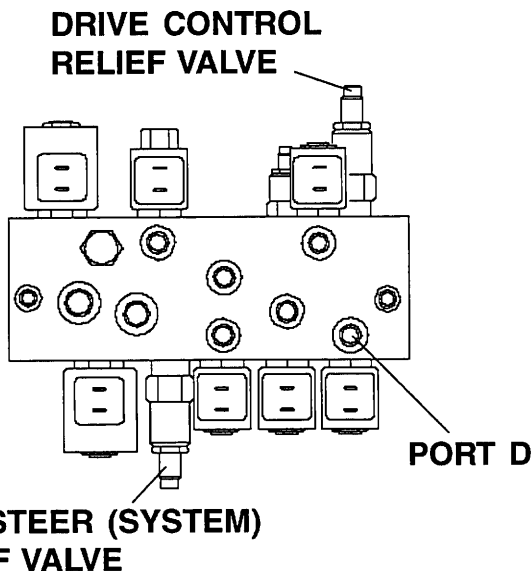

Relief Valve Locations.

DRIVE SYSTEM RELIEF VALVE

To check drive system relief valve, connect pressure gauge to port "D" of the manifold block. Select "PLATFORM" at the platform/ ground selector switch, and depress the foot pedal. Note pressure reading.

To adjust drive system relief valve, turn adjusting bolt on the end of the valve CLOCKWISE TO INCREASE PRESSURE, and COUNTERCLOCKWISE TO DECREASE PRESSURE. Turn adjusting bolt until proper reading is achieved. Lock the adjusting bolt.

HYDRAULIC FLUID RESERVOIR

The hydraulic fluid reservoir consists of the tank, a filler cap with strainer, a return line defuser, a suction filter and return filter.

HYDRAULIC RESERVOIR MAINTENANCE

Check tank for signs of leakage. Inspect tank securing bolts for tightness.

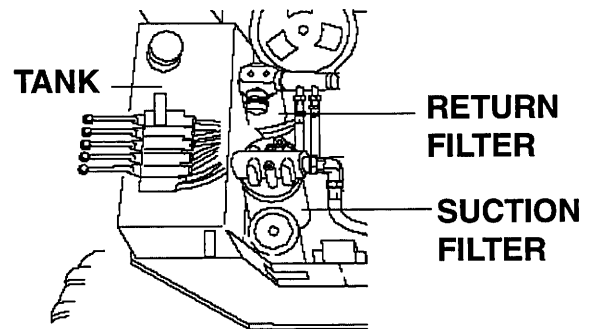

Tank and Filter Location.

FILTERS

It is important that only clean hydraulic fluid enters the hydrostatic drive system. Therefore, two hydraulic filters are used. The larger suction filter is a non-bypassing type, and is located in the charge pump inlet line. The smaller return filter has a 25 PSI bypass, and is positioned so that all the return hydraulic fluid from the lift system passes through it.

Both filters have replaceable 25 micron elements, which should be changed regularly to insure system reliability.

BOOM LIFT SYSTEM

When the power switch at the ground control station is turned and held, or the foot pedal on the platform floor is pressed and held, fluid is sent from the manifold block to the ground and platform hydraulic control valve banks.

All boom functions are then controlled by moving the proper control lever in the desired direction. THE SPEED OF BOOM MOVEMENT IS PROPORTIONAL TO THE AMOUNT OF CONTROL LEVER THROW.

Each boom function is controlled by a double acting cylinder. Each cylinder contains a counterbalance valve, which will prevent unintended movement of the cylinder should a hose or fitting develop a leak. When a boom section is lowered, fluid flows to the rod end cylinder port and to the counterbalance valve, opening this valve and allowing fluid in the base end of the cylinder to flow back to the tank.

BOOM LIFT SYSTEM TROUBLESHOOTING

Problem: No boom functions operate from either ground or platform control stations.

Check boom functions from ground control station with engine shut off, using emergency pump system.

If ALL BOOM SECTIONS CAN BE RAISED AND LOWERED slightly with the emergency pump, the ground control valve bank is good, and it will be necessary to investigate the hydraulic system, or electrical control system ahead of the control valve banks.

If any boom section FAILS TO OPERATE FROM THE GROUND CONTROL PANEL using the emergency pump, the problem may be in the ground control valve bank. Check the inoperative boom function with the platform control and the emergency pump system.

If any boom function FAILS TO OPERATE FROM THE PLATFORM CONTROL PANEL using the emergency pump, the problem may be a defective holding valve. Remove the holding valve to check for foreign material or internal damage. If faulty, the holding valve must be replaced.

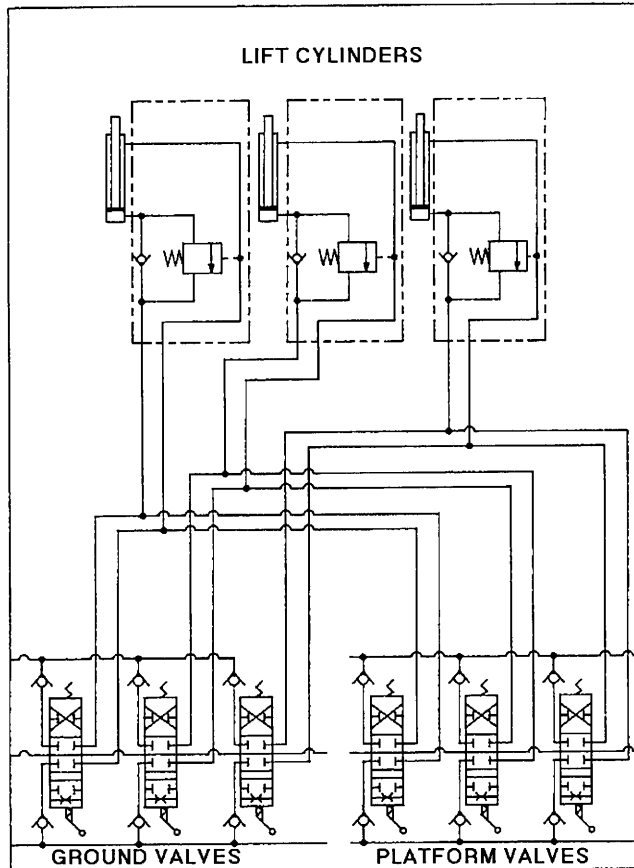

Lift System Hydraulic Schematic (AT40C).

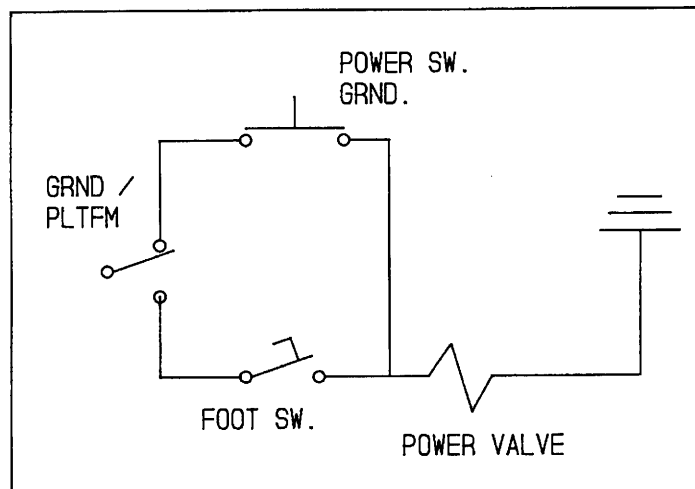

Electrical Schematic.

BOOM TELESCOPE SYSTEM

When the power switch at the ground control station is turned and held, or the foot pedal on the platform floor is pressed and held, fluid is sent from the manifold block to both the ground and platform hydraulic control valve banks.

The boom telescope (extend) cylinder is then controlled by moving the telescope control lever in the desired direction. THE SPEED OF EXTEND OR RETRACT IS PROPORTIONAL TO THE AMOUNT OF CONTROL LEVER THROW.

The boom telescope cylinder is a double acting cylinder and contains two pilot operated holding valves located at its base. These valves prevent the cylinder from moving in or out in the event of a hose or fitting failure. Cylinder movement should only occur when the control valve lever is moved to the "IN" or "OUT" position.

When extending the boom, fluid flows to the base end of the telescope cylinder, with a pilot pressure in the base valve going to open another valve in the rod end. This allows the fluid displaced by the piston inside the cylinder to flow out of the rod end and back to the tank. When the boom is retracted, fluid flow to the rod end of the cylinder opens the base end valve, allowing displaced fluid to return to the tank. This prevents the boom from extending or retracting unless called for by a control valve.

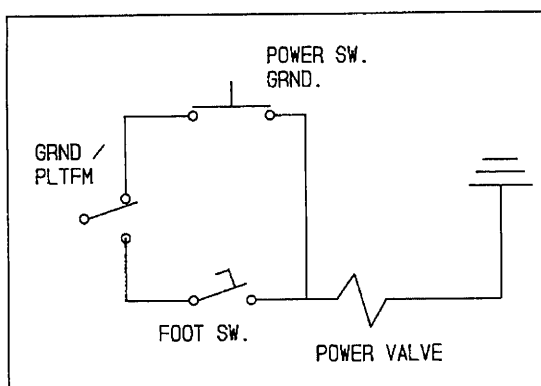

Electrical Schematic.

TELESCOPE SYSTEM TROUBLESHOOTING

Problem: Boom will not telescope from either ground or platform control stations.

Check boom telescope function from ground control station with engine shut off, using emergency pump. If boom CAN BE EXTENDED AND RETRACTED SLIGHTLY with the emergency pump, the ground control valve bank is good, and it will be necessary to investigate the hydraulic system, or electrical control system.

If boom FAILS TO EXTEND OR RETRACT FROM THE GROUND CONTROL PANEL using the emergency pump, the problem may be in the ground control valve bank. Check with the platform "Boom Telescope" control and the emergency pump.

If boom telescope function FAILS TO OPERATE FROM THE PLATFORM CONTROL PANEL using the emergency pump, the problem may be a defective holding valve, or bad cylinder rod packing. Disassemble holding valve to check for foreign material or internal damage. Replace if faulty. If necessary, disassemble cylinder for inspection.

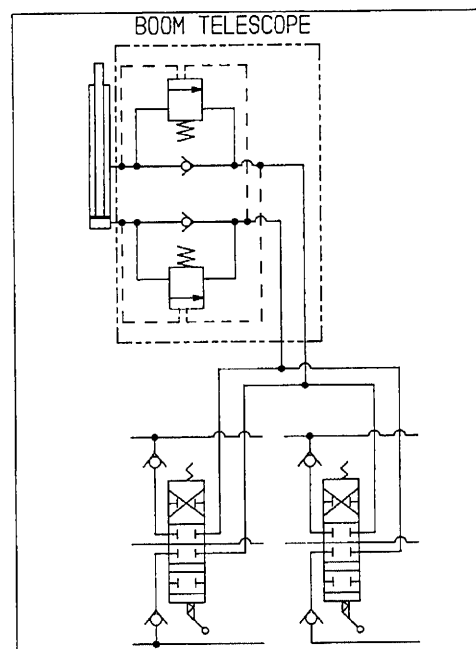

Telescope System Hydraulic Schematic.

SWING SYSTEM

When the power switch at the ground control station is turned and held, or the foot pedal on the platform floor is pressed and held, fluid is sent from the manifold block to the ground and platform hydraulic control valve banks.

Superstructure swing (rotation) is then controlled by moving the swing control lever in the desired direction, left (clockwise) or right (counterclockwise). SPEED OF SWING IS PROPORTIONAL TO THE AMOUNT OF CONTROL LEVER THROW. Pressure relief is provided by the system relief valve.

The hydraulic swing motor is a gear motor that drives through a swing gearbox to rotate the superstructure. The direction of the flow of hydraulic fluid through the motor will cause left or right swing.

The swing gearbox output pinion gear mates with teeth on the swing bearing mounted to the undercarriage.

The superstructure can swing 360 degrees (non-continuous). There is a mechanical stop to prevent overtravel.

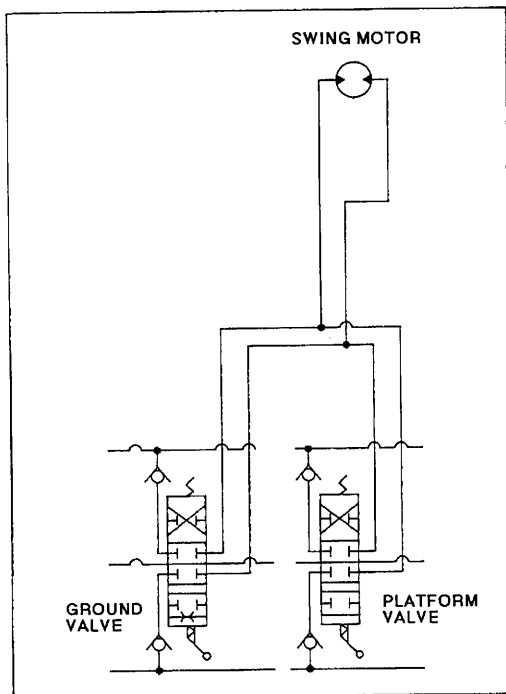

Swing System Hydraulic Schematic.

SWING SYSTEM TROUBLESHOOTING

Problem: Swing motor will not run in either direction.

Check swing function from ground control station with engine shut off, using emergency pump.

If swing DOES NOT FUNCTION with the emergency pump, check for mechanical malfunctions.

The mechanical swing stop may be preventing rotation in one direction. Try to operate swing function in opposite direction.

The swing gearbox pinion shaft may be broken. Remove and disassemble worm drive swing gearbox and replace pinion shaft. Reinstall gearbox. Be sure bolt heads are recessed in the motor mounting bracket. Check for proper gear adjustment.

The hydraulic swing motor shaft may be broken or siezed. Replace swing motor.

The swing motor pinion key to the gearbox may have sheared off. Replace key.

SWING GEAR ADJUSTMENT

Check adjustment of pinion gear teeth with superstructure in stowed position. If the pinion gear teeth are not engaged properly to the teeth on the swing bearing, loosen the four mounting bolts holding the swing motor mounting bracket.

A keeper plate (on the underside of the superstructure) holds the alignment of the eccentric that positions the swing motor. Remove the keeper mounting bolt, and use a hammer and the keeper plate to rotate the eccentric until the pinion gear teeth mesh properly.

Rotate the eccentric to obtain .004 to .006" (.10 to .15 mm) gap at gear teeth. Check for

minimal backlash and NO INTERFERENCE throughout entire range of swing gear travel. Lock the eccentric in place with the keeper plate. Tighten the mounting bolts to the recommended torque.

PLATFORM LEVELING SYSTEM

The platform leveling system automatically keeps the platform level, using a master/slave cylinder arrangement. As the upper boom is raised or lowered, fluid is forced from one cylinder to the other in a closed loop, which keeps the platform parallel to the ground in any boom position. Due to slight internal leakage, fluid may at times need to be added to the leveling circuit through the platform leveling control valve.

The platform level system is only controlled from the platform controls. The ground/ platform selector switch on the ground control panel must be in the "PLATFORM" position. With the foot switch depressed, you can now level the platform by moving the platform level control lever in the direction desired. AMOUNT OF CONTROL LEVER THROW CONTROLS SPEED OF LEVEL.

Two holding valves on the slave cylinder act as safety valves in case of a hose or fitting failure. The holding valves prevent unintended travel of the platform through the use of a counterbalance valve, which is opened only by pilot pressure from the control valve or master cylinder.

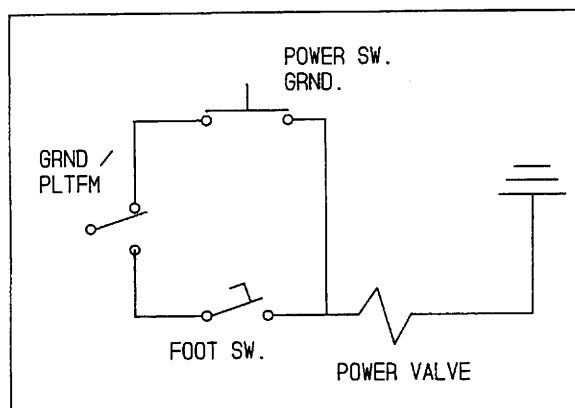

Electrical Schematic.

PLATFORM LEVELING SYSTEM TROUBLESHOOTING

Problem: Platform will not react to platform level control lever movement.

With foot pedal depressed, move control lever in both directions. If platform DOES NOT RESPOND at all, one or both solenoid activated control valves may not be shifting. If platform ATTEMPTS TO MOVE or LEAKS DOWN (slowly drifts out of position), the problem is at slave cylinder.

Problem: Platform leaks down.

Remove line from the slave cylinder holding valve to control valve.

If platform leaks down and hydraulic FLUID FLOWS from holding valve, remove holding valve and inspect it for damage or dirt. Clean or replace as necessary.

If platform leaks down, but NO FLUID FLOWS from holding valve, problem is in slave cylinder. Remove, inspect and repack the slave cylinder as needed.

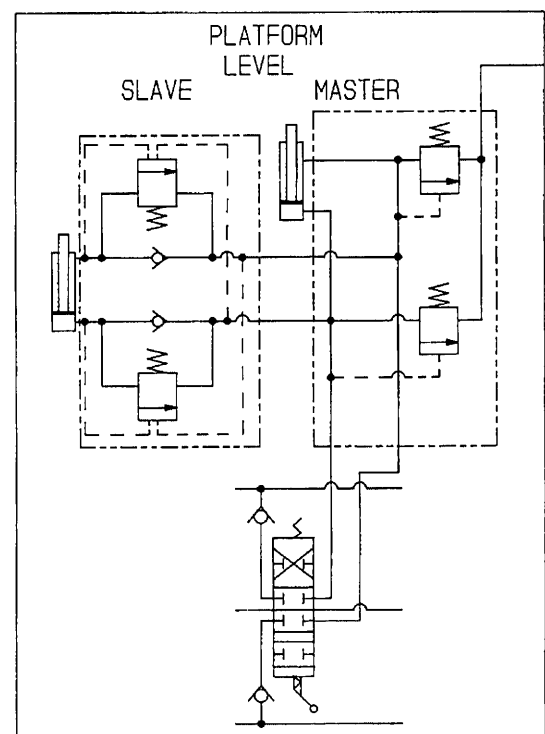

Platform Leveling Hydraulic Schematic.

PLATFORM ROTATE SYSTEM

The platform rotate circuit consists of a rotary actuator locked in position by a double acting pilot operated check valve. The platform rotate system is only controlled from the platform controls.

The ground/ platform selector switch on the ground control panel must be in the "PLATFORM" position. With the foot pedal depressed, you can now rotate the platform by moving the platform rotate control lever in the direction desired. SPEED OF ROTATION IS PROPORTIONAL TO THE AMOUNT OF CONTROL LEVER THROW.

ROTATE SYSTEM TROUBLESHOOTING

Problem: Platform will not react to platform rotate control lever movement.

Check pressure on each side of rotator to confirm control valve is working correctly.

Check the fixed orifice in the hydraulic lines between the platform control valve and rotary actuator to ensure flow.

If rotator works IN ONE DIRECTION, look for physical constraints or foreign material restricting platform rotation.

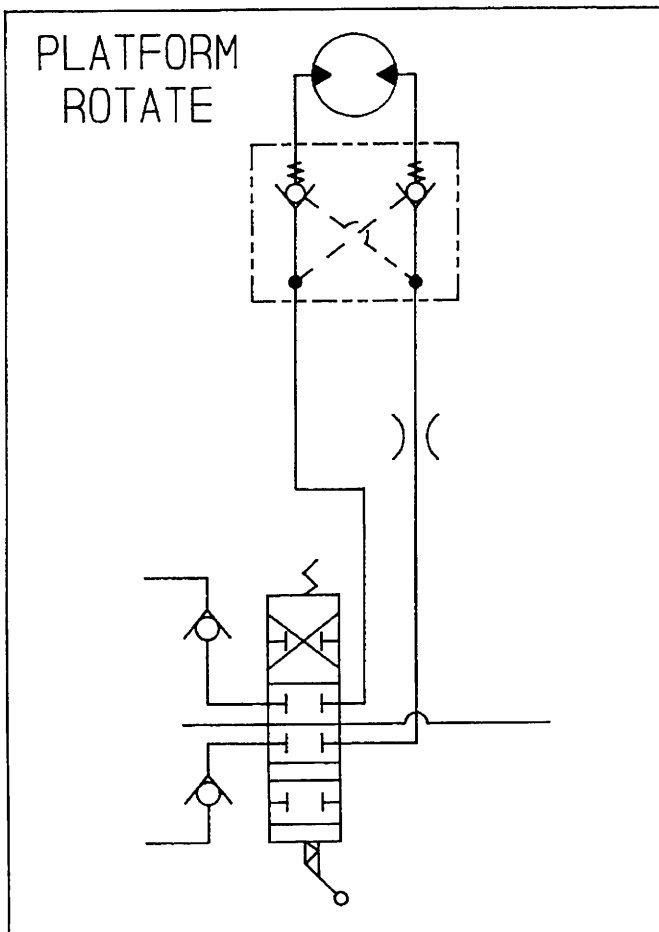

Platform Rotate Hydraulic Schematic.

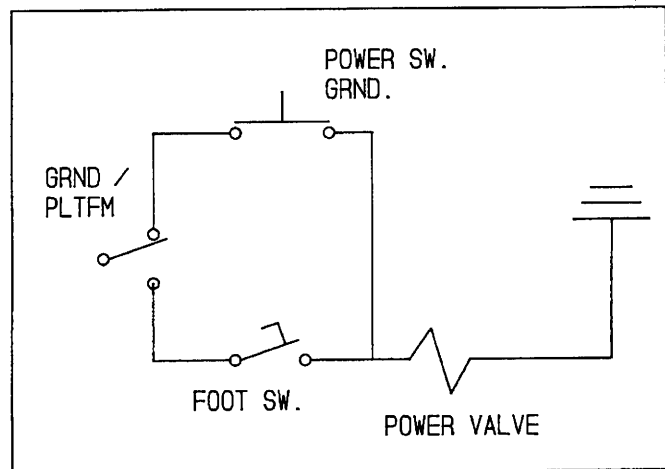

Electrical Schematic.

STEER SYSTEM

The steering system is controlled by two solenoid operated directional control valves mounted in the hydraulic system manifold block. These valves are activated by a thumb button on top of the drive control lever. When the thumb button is pressed to steer "LEFT" or "RIGHT", the valve spools shift to allow fluid flow to either the rod end or blank end of the steer cylinder. The blank end of the steer cylinder is attached to the undercarriage, while the rod end is connected to the steering axle linkage. There is a relief valve (shared with the lift system) in the hydraulic system manifold block.

STEER SYSTEM MAINTENANCE

Check all pins on steering linkage for excessive play, and ensure that all clips are in place and secure. Lubricate linkage as necessary. Check steering cylinder pins for excessive play. Check cylinder and hoses for hydraulic fluid leakage and security.

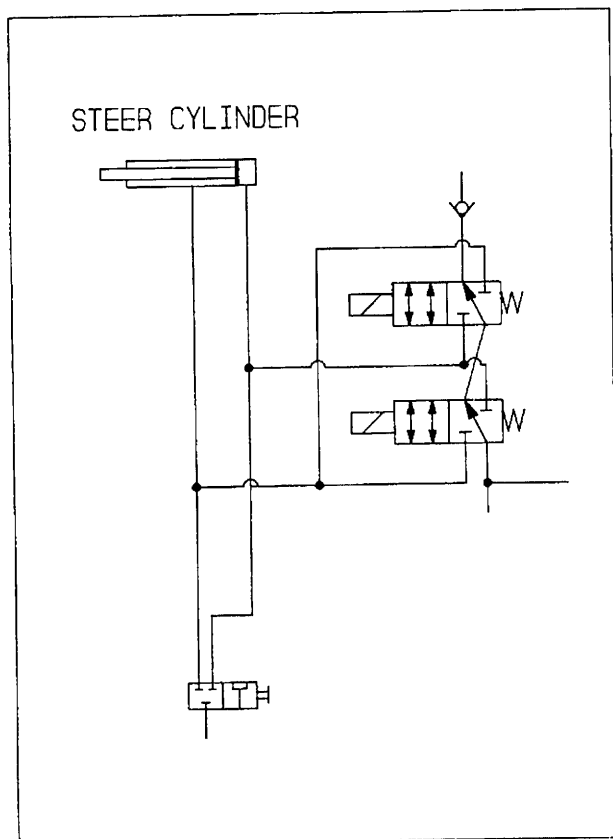

Steer System Hydraulic Schematic.

STEER SYSTEM TROUBLESHOOTING

Problem: Unit will not steer; all other functions operate.

Steering cylinder may not be mechanically connected to steering linkage. Check for disconnected or damaged steering linkage.

The steering solenoid valves may not be shifting. The valve spools may be stuck, the solenoids may not be energizing, or there may be open wires in the steering circuit.

Locate steering valves on manifold. Check to see if the solenoids located on these valves are being energized. If power is reaching the solenoids, either one or both solenoids are defective or a valve spool is obstructed. Remove valves and inspect, clean, repair or replace as needed. If solenoids are not being energized, check for continuity in the wire harness to the steering control switch on the drive lever.

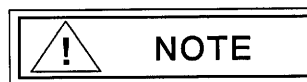

On units with the Tow Package option, check the steering tow release valve for proper position.

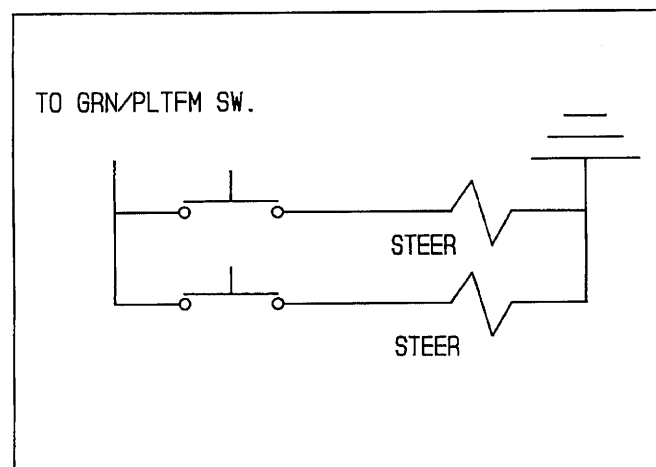

Steer System Electrical Schematic.

DRIVE SYSTEM

Following is a description of the major components of the CONSTRUCTOR drive system.

HYDROSTATIC TRANSMISSION

Hydrostatic drive systems are used to propel many types of equipment in numerous industries. The hydrostatic transmission on the CONSTRUCTOR consists of a variable displacement pump connected by hydraulic lines to a two speed motor.

A. DRIVE PUMP

This hydrostatic pump, driven by the engine, is a variable displacement axial piston pump with a control lever connected directly to a

tiltable "swashplate". With the engine running and the control lever in the center (neutral) position, there is no stroking of the pistons and no fluid flow out of the pump.

When the pump control lever is moved in the "FORWARD" direction, fluid will flow out of the pump in one direction. When "REVERSE" is selected, fluid will flow from the pump in the other direction.

B. DRIVE MOTOR

This is a two speed motor coupled to the drive train. As hydraulic fluid from the pump enters one port or the other, the motor shaft will rotate in one direction or the other. Inside the motor, system pressure against the piston causes it to slide down the inclined face of a "swashplate" resulting in output rotation. The two motor speeds are achieved by adjusting the "swashplate" angle. The motor is normally in "LOW" speed. When "HIGH" speed is selected, fluid flow from a valve on the manifold block shifts the drive motor "swashplate" to a lesser angle, resulting in higher shaft rotation speed (but lower torque).

The pilot pressure for the shift to "HIGH" speed originates at the drive system charge pump. Fluid is then directed to the drive motor shifting unit through the high speed solenoid valve which is mounted on the valve manifold block. Refer to "Machine Specifications" for proper system pressures.

The system has a cross port relief valve (mounted to the undercarriage) to prevent component damage in either direction. The drive system will only develop sufficient pressure to move the machine.

Drive Motor Maintenance

Check all securing bolts for tightness. Check all hoses for security and signs of chafing.

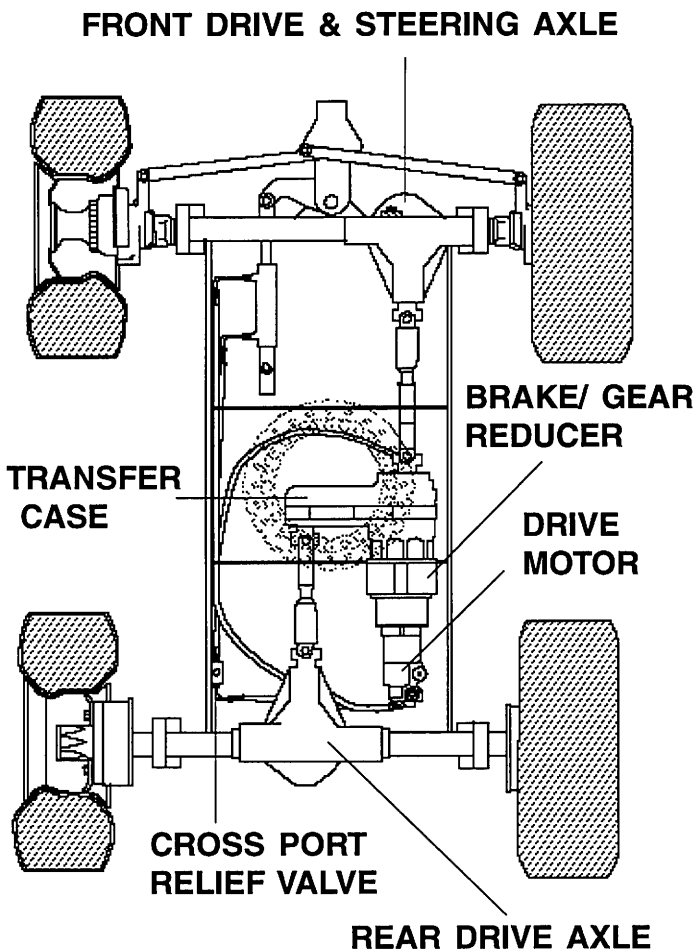

Drive System Components.

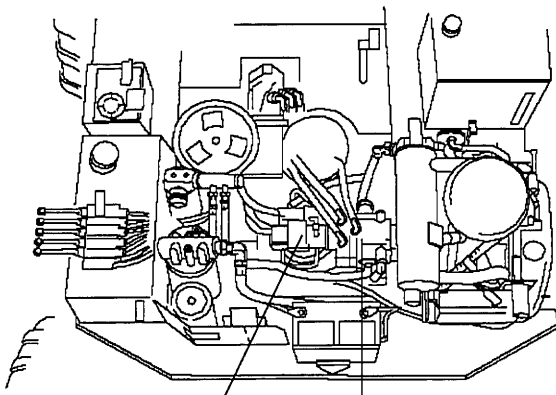

CONTROL CIRCUIT COMPONENTS

DRIVE PUMP

Drive System Components.

CONTROL CIRCUIT COMPONENTS

A. DRIVE PUMP ACTUATOR (STROKE) CYLINDER

The drive “swashplate” (which varies pump direction and flow) is controlled by an actuating cylinder. This spring centered cylinder is controlled by the directional control valve (platform drive valve) at pressures up to the drive control relief valve setting. When the boom is raised, the center port of the actuating cylinder is opened to tank through a low speed drive solenoid valve, which limits the cylinder stroke (and machine speed).

COUPLING FROM ENGINE (REF)

DRIVE CONTROL PUMP

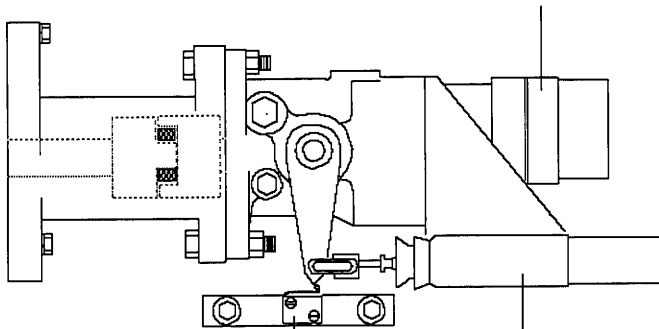

NEUTRAL SENSE MICROSWITCH

ACTUATOR CYLINDER

Control Circuit Components.

B. DRIVE CONTROL VALVE

The drive control valve is a spring-centered, variable flow, two-way valve. Hydraulic pressure does not reach the stroke cylinder until the foot pedal is depressed and the drive control handle is pushed in the desired direction. When the stroke cylinder is forced to one side, the hydraulic fluid from the other side of the cylinder travels back through the drive control valve and to the lines leading to the tank. When the handle is brought to the center position, both lines from the cylinder drain to the tank, allowing the drive pump to return to the center position.

C. DRIVE SYSTEM CONTROL PUMP

The drive control pump is the segment of the tandem pump mounted farthest from the engine. This gear pump delivers a constant pressure to the drive control valve and the brake system.

To set the pressure, install a pressure gauge in the circuit and adjust the pressure relief valve, which is mounted on the hydraulic system manifold block. Loosen the nut on the valve and adjust the valve to the correct pressure. Tighten the nut, watching that the pressure does not change. Remove the gauge.

D. NEUTRAL SENSE MICROSWITCH

The neutral sense microswitch is depressed when the stroke arm is in the neutral position. With the foot pedal depressed and the stroke arm off of the microswitch, the brakes are released and the movement alarm sounds.

DRIVELINE BRAKE/ SPEED REDUCER

The spring applied, hydraulically released brake is combined in a single unit with a single stage speed reducer. This combined unit is mounted between the drive motor and the transfer case.

The brake is pressurized, causing it to release, whenever:

- the foot pedal on the platform floor is pressed and held, AND
- the drive controller is moved from its center (neutral) position.

If, at any time during normal operation, the operator moves the drive controller to "NEUTRAL" or releases the foot pedal, the brake will engage, causing the machine to stop traveling. Driveline brake engagement time is determined by the setting of the needle valve in the brake circuit, at the hydraulic system manifold block.

This brake functions mainly as a parking brake. The hydrostatic drive system performs the primary braking function.

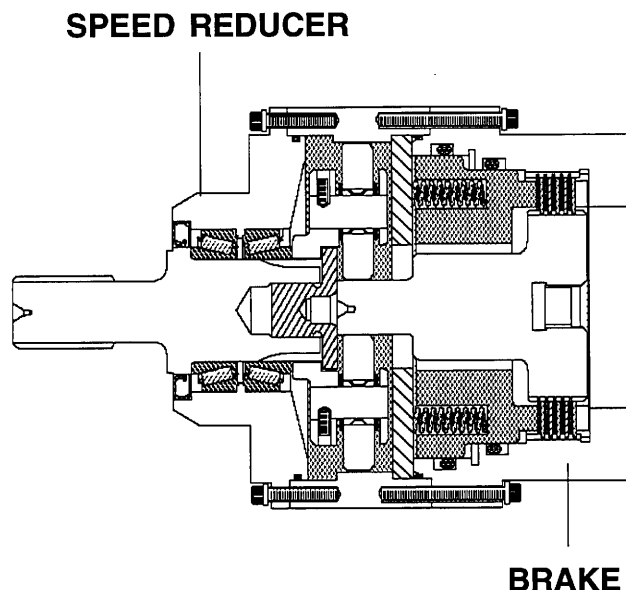

Driveline Brake/ Speed Reducer.

The speed reducer is a single stage planetary gear reducer containing a sun gear and a set of planet (or satellite) gears mounted to a carrier. The speed reducer is in the drive train to reduce the drive motor RPM's and to develop the torque required to drive the machine. Speed reducer output is transmitted directly to the transfer case.

DRIVELINE BRAKE/ SPEED REDUCER MAINTENANCE

Check brake oil level. Check the gearbox oil level. Inspect gaskets for damage. Check for worn out brake discs or clogged breather plug. Check all securing bolts for tightness. For maintenance and disc alignment, the brake may be released using pressure as low as 250 PSI.



AFTER BRAKE SERVICING OR REPLACEMENT, TEST THE BRAKES TO ENSURE NO AIR IS TRAPPED IN THE BRAKE LINE, AND BLEED THE LINE IF NECESSARY.

DRIVELINE BRAKE/ SPEED REDUCER REPLACEMENT

Remove brake line, and drain the hydraulic fluid from the line. Open the drain plug on the brake, and drain the fluid. Remove the bolts that hold the drive motor to the transfer case through the brake/ speed reducer unit. Separate the brake/ speed reducer from the motor and transfer case.

Position the new brake/ speed reducer unit to the drive motor. Align the drive motor and brake/ speed reducer with the transfer case. Install the bolts and tighten.

Attach the brake line. **BE SURE THE BRAKE DRAIN PLUG IS CORRECTLY INSTALLED.** Add hydraulic fluid.

TRANSFER CASE

The transfer case distributes the drive motor torque equally to the front and rear axles. The transfer case is locked into "4WD LOW" range, in order to maintain the correct gear ratio for the low speed, high torque requirements of the machine. If the transfer case is replaced, it is VERY IMPORTANT that the new unit is also locked into "4WD LOW".

DRIVE SHAFTS AND COUPLINGS

DRIVE SHAFT MAINTENANCE

Check the drive shaft securing bolts for tightness. Check the drive shafts and couplings for cracks and damage.

DRIVE SHAFT REMOVAL

Remove nuts and bolts or U-bolts from each end of the drive shaft and remove shaft.

DRIVE SHAFT INSTALLATION

Position the drive shaft. The U-joints at each end of the shaft must be positioned "in phase". Align the drive shaft to the transfer case and install bolts or U-bolts and nuts. Align the drive shaft to the axle yoke and install U-bolts and nuts. Tighten nuts.

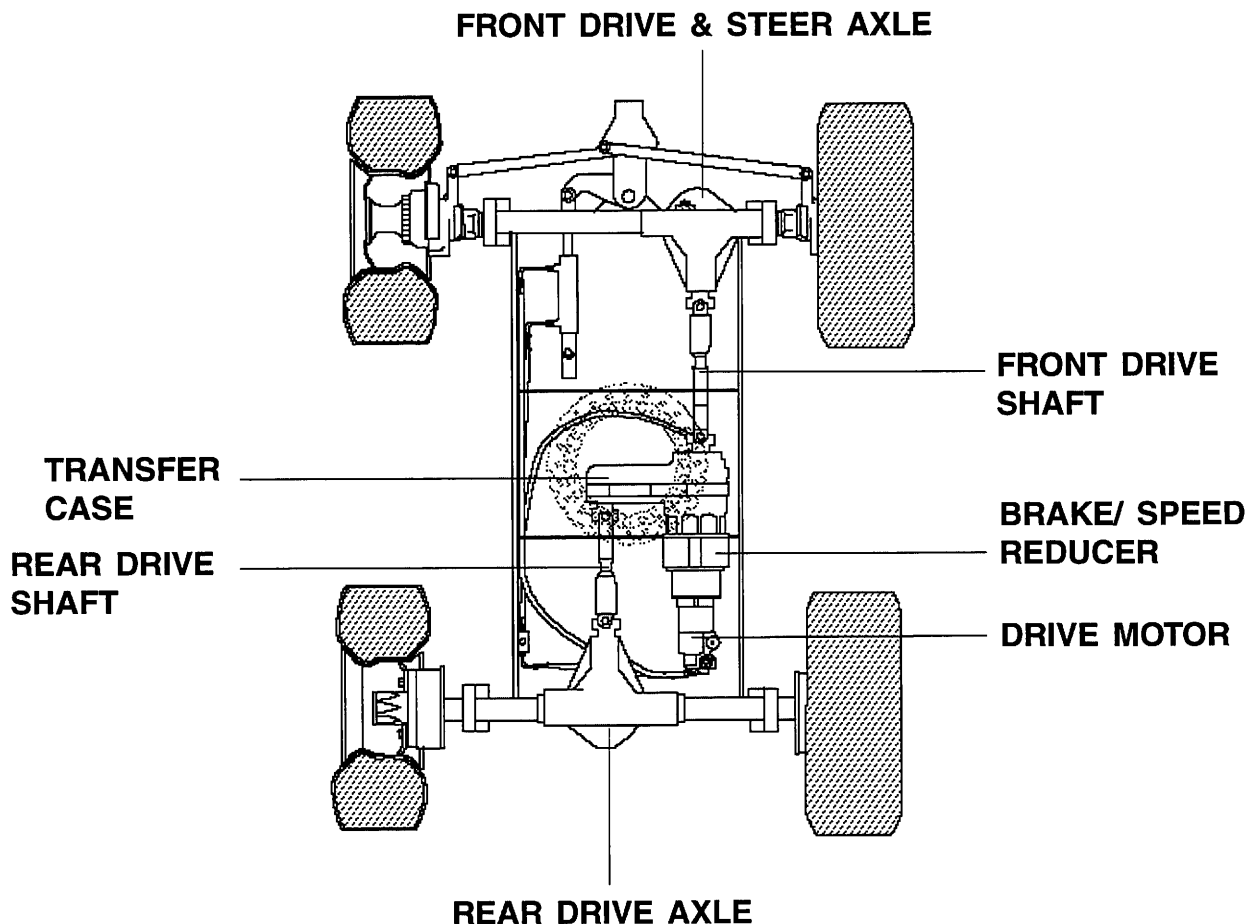

Drive System Components.

REAR DRIVE AXLE

The rear (non-steering) drive axle assembly is a standard Ford light truck axle, with a hypoid gear set consisting of a ring gear and an overhung drive pinion supported by two opposed tapered roller bearings.

Pinion bearing preload is maintained by a pinion nut and selective shims, assuring seating of the inner and outer bearings. The axle housing assembly consists of a cast center section with two steel tube assemblies and a stamped center cover.

If center cover is removed, replace gasket or use RTV sealant (Ford Part# E7TZ19562-a or equivalent).

If removal or adjustment of the internal gears is required, it is recommended that Ford Truck Shop Manual FPS-12107-88A be obtained.

Axle identification numbers are stamped on a metal tag attached to the differential assembly.

FRONT DRIVE AND STEERING AXLE

The front (steering) drive axle is mechanically identical to the rear axle, except for several unique parts related to steering and front wheel drive.

Manual locking hubs are mounted to the front axle. The pointer on the hub center bar must point to the notch under the word "LOCK" on the hub lock cap. The hub center bar should be in the "FREE" position only when the unit is being towed.

If the hub clutch does not engage when turning the knob back to the "LOCK" position, the internal clutch teeth are butted. A slight movement of the wheel in either direction should complete the locking operation.

DRIVE AXLE MAINTENANCE

Check all securing bolts for tightness. Check the axle differentials for oil leaks. Check the differential housing oil level and top off if necessary.

DRIVE SYSTEM TROUBLESHOOTING

Problem: Unit won't drive either direction.

Connecting link from drive pump to actuator cylinder may be loose or missing (See "Drive System Service").

Brakes may not be releasing due to faulty neutral sense microswitch, or the brake valve may not be shifting.

Problem: Unit drives only one direction.

Drive valve may not be working correctly. Check pressure reading in each direction.

Actuating cylinder piston or spring centering bolt may have come loose.

Problem: Hydrostatic pump drags while in neutral.

Check stroke arm cylinder clevis adjustment.

Drive controller may be contaminated.

Problem: Movement alarm beeps while machine is in neutral.

Pump actuating cylinder or neutral sense microswitch may not be properly adjusted.

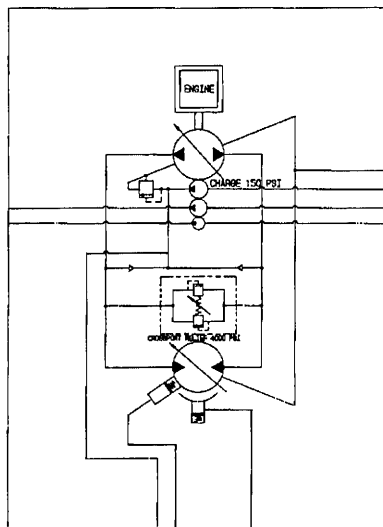

Drive System Hydraulic Schematic.

Problem: Machine jerky when movement is started.

Inspect control linkage for proper adjustment.

Pump actuating cylinder or neutral sense microswitch may not be properly adjusted.

Inspect charge check valves in drive pump.

Problem: Loss of power.

Check drive control system for proper actuator stroking (should operate at any drive system pressure).

Check drive pump charge pressure.

- If pump charge pressure is low, inspect suction filter and lines for restrictions.
- Inspect charge relief valve.
- Inspect charge pump.

Check drive system pressure.

- If system pressure is low, inspect charge check valves in drive pump.
- Adjust or replace boom cross port relief valve.

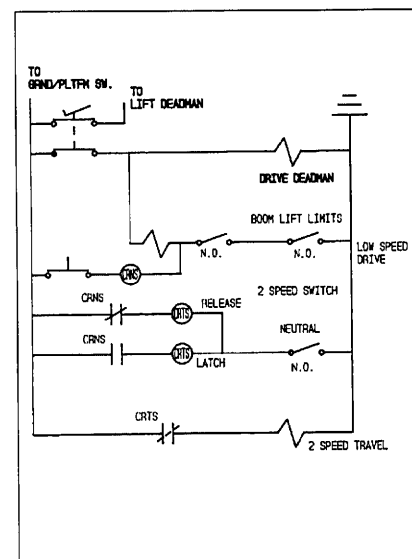

Drive System Electrical Schematic.

DRIVE SYSTEM SERVICE

PUMP ACTUATING (STROKE) CYLINDER ADJUSTMENT



ADJUSTMENTS MUST BE MADE WITH WHEELS OFF THE GROUND, AND LOWER BOOM SLIGHTLY RAISED AND FIRMLY SUPPORTED.

WHEELS MAY ROTATE DURING THIS PROCEDURE. STAY CLEAR OF WHEELS WHILE MAKING ADJUSTMENTS. PERSONAL INJURY MAY RESULT.

If the cylinder IS being replaced, reinstall hoses, but do not install master link. Start the engine and, with the lower boom raised, cycle the drive handle "FORWARD" and "REVERSE" several times to bleed air from the cylinder or supply lines.

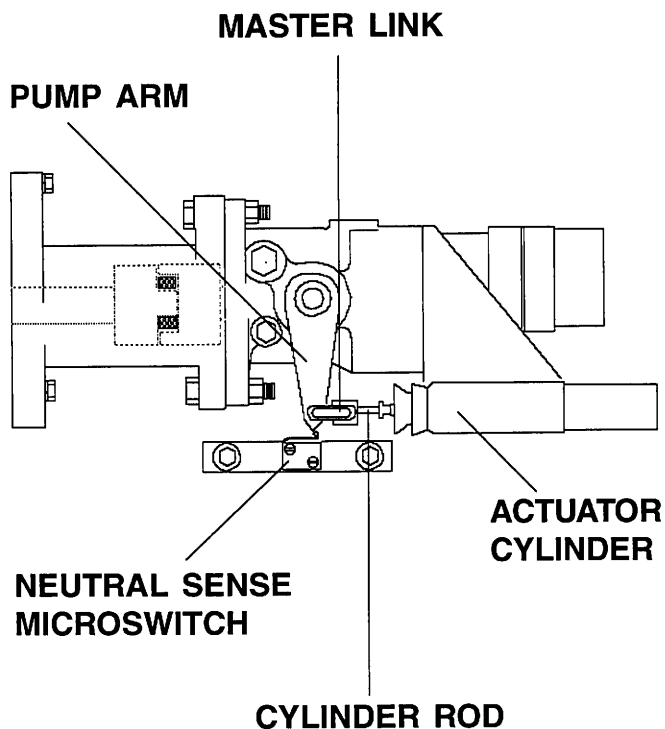

Pump Actuating Cylinder Adjustment.

If the cylinder IS NOT being replaced, remove the master link connecting the cylinder rod to the pump arm. Start the engine. With the drive handle in neutral, the pump arm will center itself.

With the engine running and the drive handle in neutral, loosen the stop nut and adjust the rod end so you can easily slide the master link in position. Install the master link and retainer. Lock the rod end in position with the stop nut.

After adjusting the actuator cylinder, the neutral sense microswitch must also be adjusted. Turn off the engine. The wheels should still be off the ground.

Turn the ground/ platform selector switch to "PLATFORM", and turn on the ignition, but **DO NOT START THE ENGINE**. Depress the foot pedal and block it in position. The movement alarm will begin to sound.



THIS PROCEDURE IS USED ONLY IN MAKING THE ADJUSTMENT TO THE NEUTRAL SENSE MICROSWITCH.

NEVER BLOCK THE FOOT PEDAL IN THE DEPRESSED POSITION WITH THE ENGINE RUNNING OR THE WHEELS TOUCHING THE GROUND. SERIOUS INJURY CAN RESULT.

Loosen the two mounting block bolts. Move the mounting block so that the stroke arm depresses the microswitch (movement alarm will stop). Adjust another 1/32" and re-tighten the bolts.

Move the arm slightly in both directions. If adjustment is correct, the alarm will begin to sound with approximately equal movement in either direction.

Remove the block from the foot pedal.

EARLY VERSION

LATER VERSION

FREE PLAY (BOLT IS TOO LOOSE)

FREE PLAY (IF NUT IS TOO LOOSE)

ROD END

ROD END

FREE PLAY (BOLT IS TOO TIGHT)

FREE PLAY (IF NUT IS TOO TIGHT)

CENTERING SPRING BOLT

CENTERING SPRING NUT

Centering Spring Adjustment.

ACTUATOR CYLINDER CENTERING SPRING ADJUSTMENT

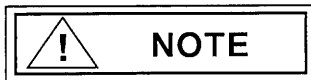

The stud and nut (or socket head bolt on earlier versions) used to adjust the centering spring on the actuator control cylinder is installed with "Loctite" and should not be readjusted as a maintenance item. It should only be adjusted if the centering spring adjustment is found to be incorrect.

Remove and clean centering spring nut and stud (or bolt). Check all screw threads for damage. Put a couple of drops of "271 Loctite" or equivalent on the threads. Reassemble and tighten until the CYLINDER ROD END HAS NO FREE PLAY. If nut (or bolt) is made too tight, the spring will be loose.

CHARGE RELIEF VALVE INSPECTION

Remove plug on side of the drive pump housing. Slide the spring and poppet out of the housing. DO NOT ALTER THE SHIMS, OR INTERCHANGE PARTS WITH ANOTHER VALVE. Inspect the poppet and seat in housing for damage and foreign material. Replace parts as required and reinstall into housing.

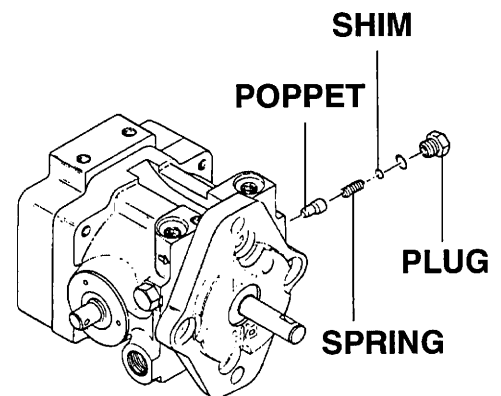

Removing Charge Relief Valve (Pump Shown Upside-Down).

LIP SEAL REPLACEMENT

Lip type shaft seals are used throughout the drive pump and motor. These seals can be replaced without disassembling of the unit. Replacement of either the input or output shaft seals, however, requires removal of the pump or motor from the machine.

Pry the seal out of the housing bore, USING CARE NOT TO DISTORT THE HOUSING, OR DAMAGE THE BORE OR THE SHAFT. The seal is not reusable.

Wrap the shaft extension in thin plastic and lubricate with hydraulic fluid to prevent damage to the seal during assembly. Slide the seal over the shaft and carefully press it into the housing bore.

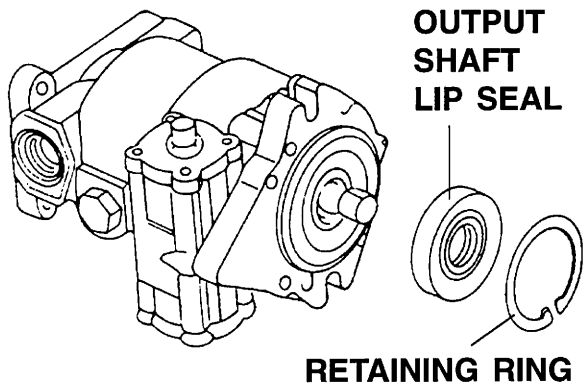

Drive Motor Lip Seal Replacement.

When replacing trunnion shaft seals, the retaining rings and washers must be removed before removing the seals. Washers should be replaced if noticeably bent or distorted.

CHARGE PUMP REMOVAL AND INSTALLATION

Note orientation of the charge pump housing to adjacent assembly, and scribe lines or make punch marks to insure proper relocation. Clean shaft extension to remove all sharp edges, burrs and abrasive residue to prevent shaft seal damage.

Remove hex head screws and slide charge pump housing and cartridge (gerotor assembly) off of the shaft. Remove and discard the drive pin. REMOVE SHAFT SEAL AND BEARING FROM HOUSING ONLY IF REPLACEMENT IS NECESSARY.

Examine wear surfaces of pump cartridge for excessive scratching or heavy wear patterns. If replacement is necessary, both parts of the cartridge must be replaced as a unit. DO NOT REPLACE OR EXCHANGE INDIVIDUAL PARTS WITHIN THE CARTRIDGE. The drive pin is not reusable, and should always be replaced. Visually inspect bearing, o-ring and shaft seal, and replace as required.

Coat both sides of the pump cartridge and housing face with hydraulic fluid. Install new drive pin into shaft, and slide pump cartridge into place. Wrap the shaft extension with plastic, then coat with hydraulic fluid to prevent damage to shaft seal. Place o-ring into cartridge housing assembly, then slide assembly into position over shaft. Line up location marks, then insert and tighten screws.

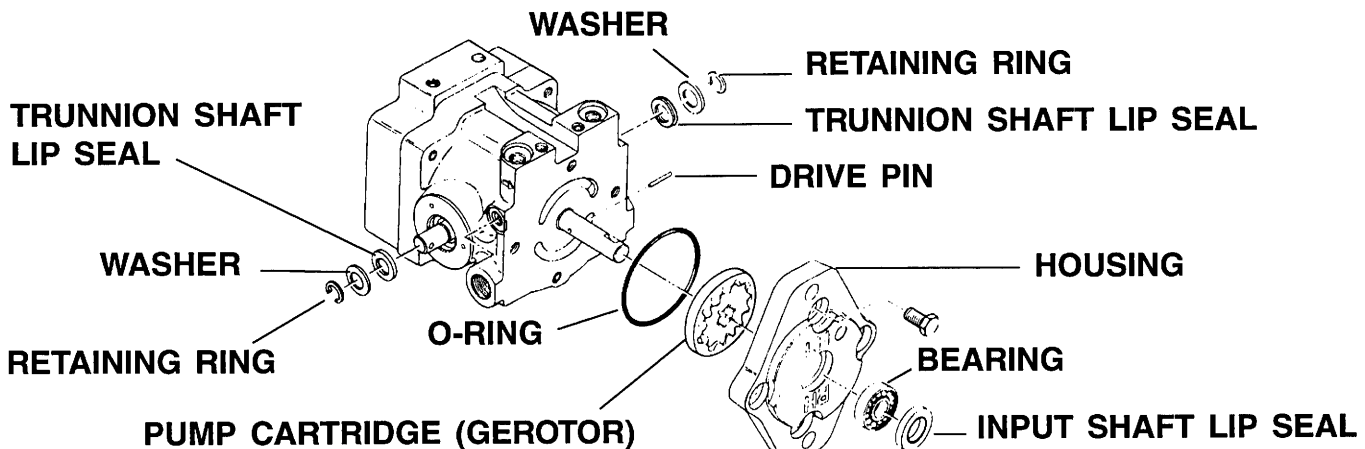

Drive Pump Lip Seal and Charge Pump Replacement (Pump Shown Upside-Down).

DRIVE PUMP INITIAL START UP PROCEDURE

Prior to installing the drive pump, inspect for shipping damage. Ensure all circuit components are clean prior to installing and filling the pump.

Fill the hydraulic tank on the machine with clean, filtered hydraulic fluid (refer to Lubrication Chart). If gravity feed does not fill the inlet line leading from the tank to the drive pump, that line must also be filled manually prior to start up. Ensure inlet line is free of restrictions, and check fittings for tightness.

Be certain that pump and motor housings are filled with clean hydraulic fluid. Place control lever in neutral. **CONTROL LINKAGE MUST BE DISCONNECTED FROM DRIVE UNIT DURING INITIAL START UP.**

Remove plug from tee in port "C" of manifold block (tee is attached to line from drive pump charge port). Slowly turn the pump input shaft (hand cranking or jogging the engine is

recommended) until fluid flows from the tee. **ENSURE THAT ENGINE DOES NOT START, AS DAMAGE TO PUMP WILL OCCUR.** Install a pressure gauge (1000 PSI capacity) in the tee with a short section of hose and a snubber or needle valve to dampen pulsations.

Start the engine and run at the lowest possible RPM until normal charge pressure has been established, then increase to full engine speed. Charge pressure should remain steady or increase. If pressure decreases, shut down the system and determine the cause.

Run system at full input and output speeds in both directions and observe charge pressure. Operate system for at least fifteen minutes, then shut down and replace inlet filter. Remove gauge and plug port. Check fluid level in tank and fill as necessary. Unit is ready for operation.

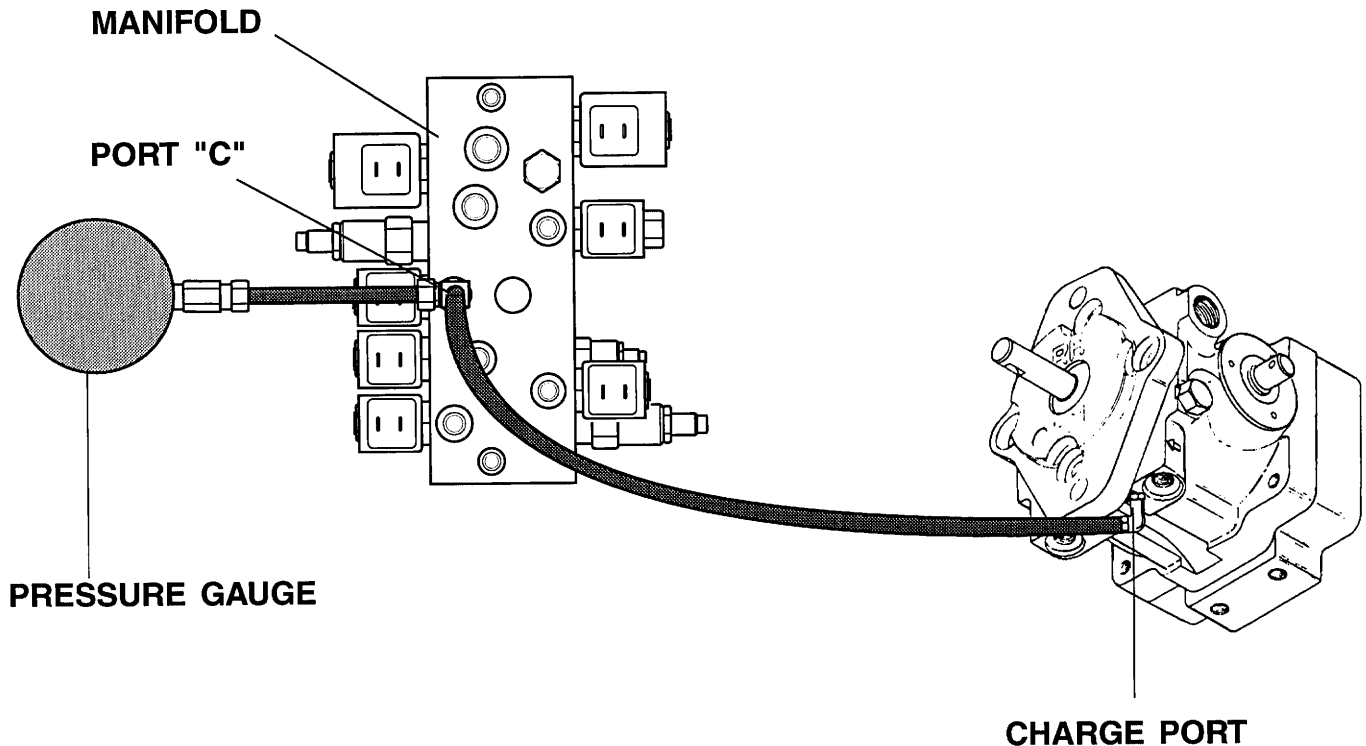

Charge Pressure Check.

ELECTRICAL SYSTEM

Following is a description of the major components of the CONSTRUCTOR electrical system.

12 VOLT BATTERY

One 12 volt battery supplies the electrical current required to operate the electrical circuit. The battery is located on the superstructure, near the engine and hydraulic fluid tank.

BATTERY REPLACEMENT

To remove the battery, follow these procedures:



BEFORE REMOVING THE BATTERY FROM THE MACHINE, TURN OFF THE IGNITION SWITCH. THERE SHOULD BE NO POWER TO THE MACHINE.

Be sure all power to the machine is shut off. Disconnect the battery cables.



Always disconnect the negative battery cable first.

Loosen the bolt holding the battery hold down bracket, and remove the battery.

To install, place the battery in its proper location. Position the battery hold down bracket and tighten the bolt. Connect the battery cables.



Always connect the positive battery cable first.

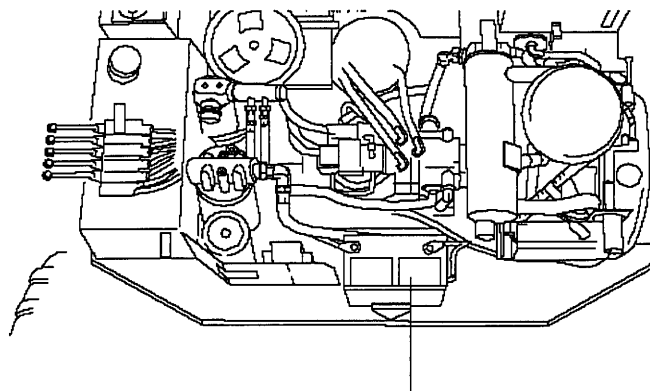

BATTERY

Battery Location.

BATTERY MAINTENANCE

Check battery and surrounding area for signs of damage or corrosion.

Check battery terminals for:

- **Corrosion.** Regularly clean connections and apply a non-metallic grease or protective spray to retard corrosion.
- **Loose connections.** Be sure all cable connections are tight, and that good contact is made to terminals.
- **Broken or frayed cables.** Be sure all cable connections are good, and that no loose or broken wires are exposed. Replace as needed.

Check battery electrolyte level. Replenish the electrolyte, if necessary.



NEVER ADD ADDITIONAL ACID TO THE BATTERY.

Remove vent caps before filling and **USE ONLY DISTILLED WATER**. Fill all cells to the proper level. Do not overfill. Fill to level indicator (or 1/2 inch over the top of the separators if there is no level indicator). Do not allow the electrolyte level to drop below the top of the separators, since this will lead to shortened battery life.

Excessive water usage can indicate that the battery has been overcharged, has been subjected to excessively high temperatures, or is nearing the end of its service life.

Keep battery clean. Wash the top of the battery, making sure the vent caps are in place. Do not allow cleaning water or other foreign matter to enter the cells. Use a solution of bicarbonate of soda and water to wash battery if there is an accumulation of acid.

BATTERY TROUBLESHOOTING

Check battery terminals for corrosion, loose connections and broken or frayed cables.

Check all cells with a hydrometer for variation in specific gravity. A variation of 0.03 points or more between cells is cause for concern. Mark the low cells.

Recharge the battery as recommended by the manufacturer.

Recheck specific gravity of all cells after recharging. A fully charged battery should indicate between 1.25 and 1.28. A variation of more than 0.03 points between cells is an indication that the battery should be replaced.

EMERGENCY STOP BUTTONS

Two emergency stop buttons (one on the ground control panel and one at the platform control panel) act as power “on/ off” switches. Both switches must be “ON” to operate the machine. When either of the emergency stop buttons is depressed, all functions stop immediately and the wheel brakes are automatically applied.

When troubleshooting the electrical circuit; if there is a problem with the emergency stop button, check the wiring to the button. If the wiring is correct, replace the emergency stop button.

FOOT PEDAL SWITCH

The foot pedal is a double pole, double throw switch which must be fully depressed before any machine function can be operated from the platform. When the foot pedal switch is released, power to the lift and drive function solenoid valves is terminated, and all machine functions stop. The foot pedal switch is located on the floor of the platform.

When troubleshooting the electrical and hydraulic circuits to the platform, ensure that the foot pedal switch is depressed. Check the wiring to the foot pedal switch. If the wiring is correct, but there is a problem with the foot pedal circuit, replace the entire switch.

TILT ALARM

The tilt alarm gives an audible warning when the machine is five degrees or more out of level. The alarm can be tested by manually tipping the alarm sensor (see "Tilt alarm test" procedure). If the tilt alarm does not function, check the horn, then check the output relay.

Check the wiring. If wiring is correct, replace the alarm.

TILT ALARM ADJUSTMENT

The tilt alarm can be adjusted. Before attempting to adjust the alarm, park the machine on a flat, level surface. Fill pneumatic or liquid ballasted tires to the proper pressure.

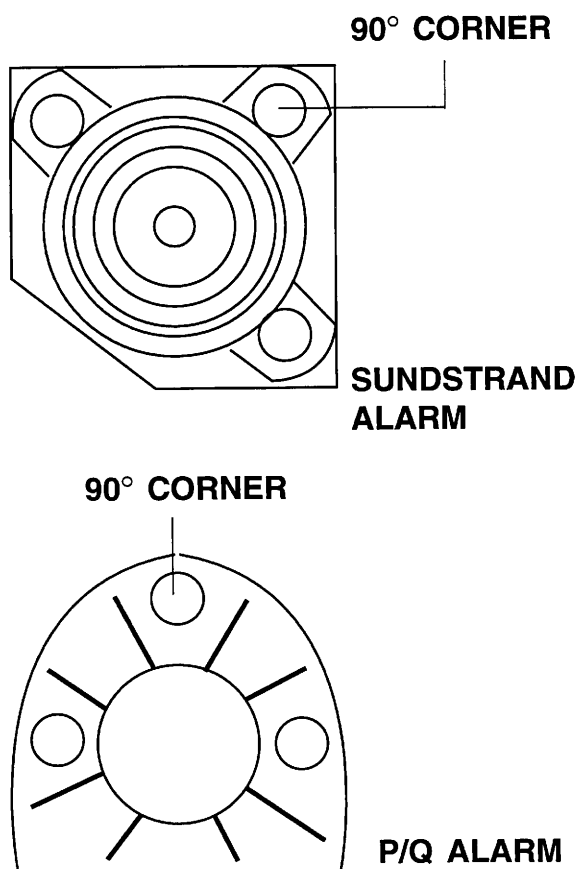

Tilt Alarm 90° Corner

Level the base of the alarm by tightening each of the three flange nuts to take up approximately one half of its spring's travel. During the remainder of the adjustment procedure, **DO NOT ADJUST THE NUT ON THE 90° CORNER.**

Check to be sure the electrical connections are correct. Slowly tighten the nut on one of the two corners **ADJACENT** to the 90° corner until the light-emitting diode (LED) just turns on, indicating that the circuit is closed. Note the position of the nut.

Loosen the nut (LED will go out), carefully counting the number and fraction of turns until the LED lights up again. Divide that number by two, and tighten the nut by this number of turns.

Adjust the nut on the **OTHER** corner adjacent to the 90° corner in the same manner. The alarm is now level, to the degree of accuracy determined by the nut adjustments and the surface on which the machine is sitting. Test the tilt alarm for proper function.

TILT ALARM TEST

Individually push down on each of the three fastened corners of the tilt alarm. There should be enough travel to cause the alarm to sound as each corner is pressed. If not, the flange nuts have been tightened too far. Loosen the nut on the 90° corner and repeat the adjustment procedure. This "Push-to-Test" feature enables the tilt alarm to be tested without losing its adjustment.

MOVEMENT ALARM

The movement alarm is activated as soon as the machine's drive controller is moved off the center "Neutral" position.



THE MOVEMENT ALARM IS PROVIDED FOR YOUR PROTECTION, AND THE PROTECTION OF PERSONS WORKING IN THE IMMEDIATE AREA.

DISABLING THIS IMPORTANT SAFETY DEVICE MAY RESULT IN DEATH OR SERIOUS INJURY.

If the movement alarm does not function, check the wiring. If wiring is correct, replace the alarm.

RELAYS

There are eight relays associated with machine functions (refer to Electrical Schematic at the back of this manual). They are:

1. Tilt Sensor and Tilt Horn (CRTH)
2. Ignition (Source) (CR3)
3. Time Delay (Starter Cutout) (CRTD)
4. Travel Speed (CRTS)
5. Shift Sense (CRNS)
6. High Throttle (CR5)
7. Starter Interlock (CRM)
8. Emergency Pump (CR2)

CIRCUIT BREAKER

There is one 20 amp circuit breaker mounted on the ground control box.

Check for a tripped breaker and re-set by pushing in the button. If the breaker trips again, the cause of the high current draw must be corrected prior to further operation.

AUTOMATIC WARNING BEACON

There are two types of optional automatic warning beacons available. One is a "strobe" type, with no moving parts, that gives an intense light. The other has a rotating reflector with a less intense light. The beacon activates whenever the ignition is on.

MECHANICAL COMPONENTS

Following is a description of the major mechanical components of the CONSTRUCTOR.

TIRES

Pneumatic 38.5 - 16.5 LT 8 ply tires are standard. Check tires for correct pressure, and inspect for cuts, sidewall damage or abnormal wear. Any tire faults **MUST BE CORRECTED** before further machine operation.

Liquid ballasted tires are an available option. Check tires for correct pressure, and inspect for cuts, sidewall damage or abnormal wear. Any tire faults **MUST BE CORRECTED** before further machine operation. Consult your tire dealer if liquid ballast is needed.

Foam filled tires are also available. Check for any significant sidewall or other damage.

CHANGING TIRES



LIQUID BALLASTED AND FOAM FILLED TIRES ARE EXTREMELY HEAVY. CARE MUST BE TAKEN TO AVOID PERSONAL INJURY.

When a tire change is necessary, **ALWAYS BLOCK THE WHEELS** before you raise the machine. Loosen and remove lug nuts, and pull off the wheel. Replace the tire, and re-install. Fasten lug nuts and tighten to proper torque. Lower the machine and remove the blocks.

WHEELS AND LUG NUTS

Front and rear wheels are different, and **ARE NOT INTERCHANGEABLE**. Check the security of the wheel lug nuts and examine the wheel rims for damage.

SUPERSTRUCTURE

Steam clean the superstructure, and inspect all welds and brackets. Check for cylinder pivot pins that turn in their mountings, which can indicate sheared pin lock bolts.

HOSES AND CABLES

Inspect all hoses and electrical cables for security and damage. Check for leaks at fittings. **ANY DAMAGED HOSES OR CABLES SHOULD BE REPLACED.**

Cables and hoses should be examined for rubbing and chafing, especially in the swing bearing area.

TOWING PACKAGE

A towing package is an available option on all **CONSTRUCTOR** models. **IF SO EQUIPPED**, the machine can be towed behind another vehicle.

Connect the machine to the tow vehicle. Disengage front (steering) axle drive hubs by turning knobs in center of hubs to "FREE" position. Pull lever provided to disengage rear drive axle, and pull control valve to allow front (steering) wheels to track the towing vehicle.

MISCELLANEOUS EQUIPMENT

Check all miscellaneous equipment mounted on the machine for secure attachment. Check for evidence of oil or hydraulic fluid leakage. Check all cables and hoses for security and damage.

CYLINDER PIVOT PINS AND PIN BUSHINGS

Check all cylinder pivot pins and pin bushings for wear. Elevate the booms and check each pin individually for rotation or movement. If pin rotates, check for a missing retaining ring. If wear is detected, the pin and bushing must be replaced.

PIN REPLACEMENT

BOOM PIVOT PIN REPLACEMENT



It is **IMPORTANT TO MAINTAIN THE CORRECT ALIGNMENT** between the boom and side plates during this operation. Any relative movement will make fitting of the pins more difficult.

Support the boom and upper structure securely (on a boom stand or similar rigid platform). Remove the retaining ring, and drive out the boom pin, taking care not to damage the inner bore.

Check bushing and replace if necessary. Install new pin and retaining ring. Apply grease to pin.

RETAINING RING

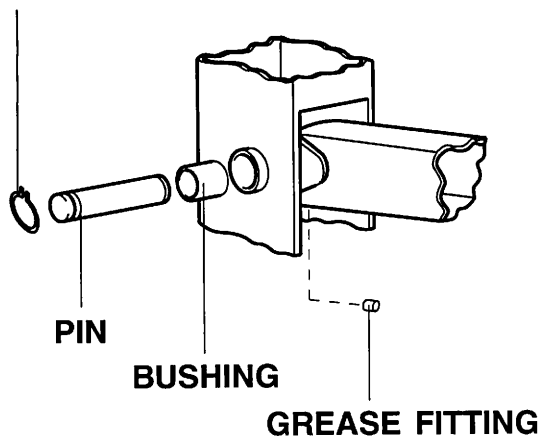

Boom Pivot Pin Replacement.

LIFT CYLINDER PIVOT PIN REPLACEMENT

SUPPORT THE BOOM. Operate the proper boom lift control to release hydraulic pressure and remove any load on the lift cylinder. Remove the pin locking bolts, **SUPPORT THE LIFT CYLINDER** and remove the pin.

Install new pin and locking bolts (lubricate bolts before installation). Apply grease to pin.

PLATFORM LEVEL CYLINDER PIVOT PIN REPLACEMENT

SUPPORT THE PLATFORM to remove the load on both master and slave leveling cylinders. Remove the pin locking bolts, and remove the pin.

Install new pin and locking bolts (lubricate bolts before installation). Apply grease to pin.

RETAINING RING

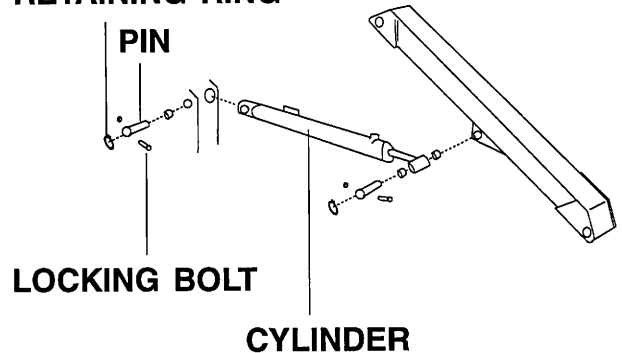

Cylinder Pin Replacement.

TELESCOPE (EXTEND) BOOM CYLINDER PIVOT PIN REPLACEMENT

Remove the pin locking bolts, **SUPPORT THE CYLINDER** and remove the pin. When changing the rod end pin, it may be necessary to extend the boom out to expose the pin.



If the telescope boom has been greased, the pin recess may be filled and not readily visible.

BOOM TELESCOPE (EXTEND) CYLINDER

The boom telescope (extend) cylinder is a double acting cylinder. It must be removed from the machine before a thorough inspection can be carried out.

TELESCOPE CYLINDER REMOVAL

Elevate the upper boom to the horizontal position. Extend the boom just enough to expose the upper cylinder pivot pin on the inner boom. Disconnect the hydraulic hoses from the cylinder. Remove the pivot pins from the inner and outer booms, and withdraw the cylinder from the boom.



With the extend cylinder disconnected, CARE MUST BE TAKEN TO PREVENT THE INNER BOOM FROM SLIDING OUT OF THE OUTER BOOM. Secure the inner boom in the fully retracted position.

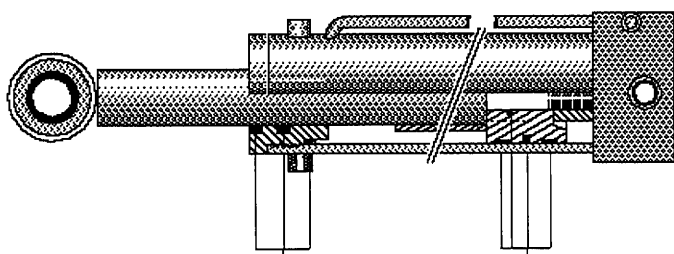

HEAD GLAND SEALS PISTON SEALS

Telescope Cylinder Seal Replacement.

TELESCOPE CYLINDER SEAL REPLACEMENT

Remove the end cap from the cylinder. Pull the cap and rod straight out of the cylinder barrel. Remove the split pin and nut from the end of the rod. Slip off the collar. Examine the rod and seals for signs of damage or wear.

Remove the old seals and install a new set.

TELESCOPE CYLINDER INSTALLATION

WITH THE UPPER BOOM IN THE HORIZONTAL POSITION, slide the telescope cylinder into the boom. Install the pivot pins and hoses.

CHECKING HOLDING VALVES

Clean the end of the cylinder, and loosen the cylinder end cap.

Stop the engine, and activate the appropriate control lever several times to dissipate residual pressure. If the cylinder subsequently begins to move, the valve is faulty and the cartridge should be replaced.



The holding valve is pre-set at the factory.

WEAR PADS

The nylon wear pads should be checked for wear approximately every six months. Fully retract the upper telescope boom section, and check the gap between the top wear pad and the outer boom section, at the front (lower) end of the boom. Inspect the side and bottom pads as well.

Then, extend the boom out, and check the gap between the bottom wear pad and the inner boom section, at the rear (upper) end of the outer boom section. Inspect the side and top pads as well.



If a pad wears to approximately 3/8" (9.5 mm) thick, it should be replaced or shimmed. Generally, only the bottom pad at the upper end and the top pad at the lower end of the boom will show wear.

REAR (UPPER END) WEAR PAD REPLACEMENT

Remove the bolts holding the bottom spacer and pad. Remove the pad (the boom may need to be extended out a short distance). Install replacement pad by hammering gently into place, then securing pad and spacer with mounting bolts. Repeat this procedure for the side and top pads if required.

FRONT (LOWER END) WEAR PAD REPLACEMENT

Fully retract the telescope boom section. Remove the pivot pin at the lower (valve block) end of the telescope cylinder, then extend the cylinder from the boom. Access can now be gained to the front top pad retaining bolts. Remove and replace pad. Retract cylinder and install the pivot pin.

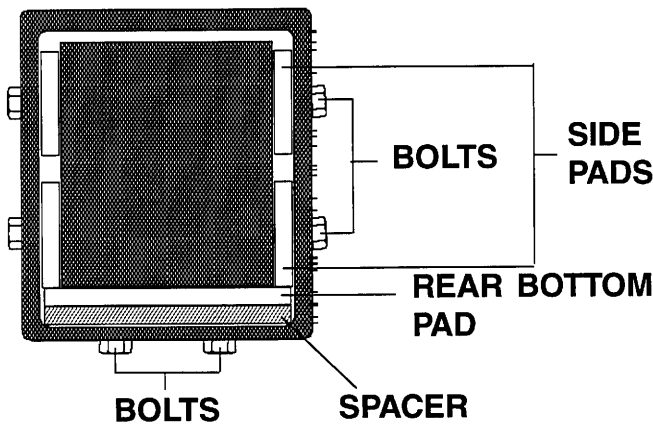

Rear (Upper) End Wear Pads.

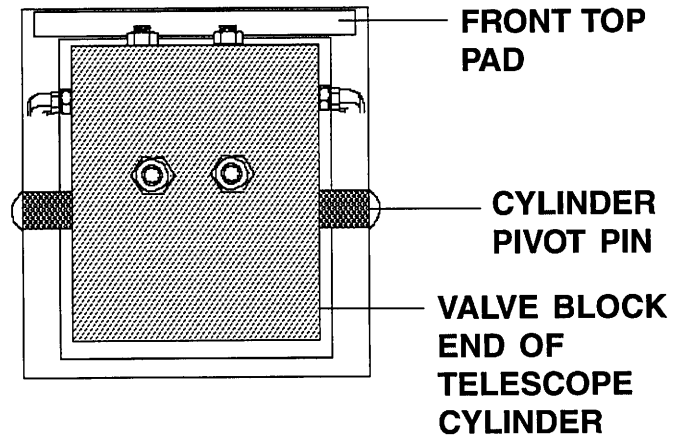

Front (Lower) End Wear Pads.

PLATFORM LEVEL CYLINDERS

The platform level cylinders are of the double acting type. The pivot pins should be checked for wear. Check the pivot pin locking bolts for tightness. The cylinders should be inspected for fluid leakage, damage and security. The seals should be replaced whenever the cylinder is serviced.

LEVEL CYLINDER SEAL REPLACEMENT

Lower the upper boom. **SUPPORT THE PLATFORM** to remove the load on both master and slave leveling cylinders. Remove the lock collar and pin. Slave cylinder seals can be replaced on the machine. Master cylinder must be removed for seal replacement.

Clean the end of the cylinder, and pull the cap and rod straight out of the cylinder barrel. **TAKE CARE NOT TO DAMAGE THE ROD SURFACE, AND GUARD AGAINST DIRT ENTERING THE SYSTEM.** Remove the split pin and nut from the end of the rod. Slip off the collar. Examine the rod and seals for signs of damage or wear.

Remove the old seals and install a new seal kit.

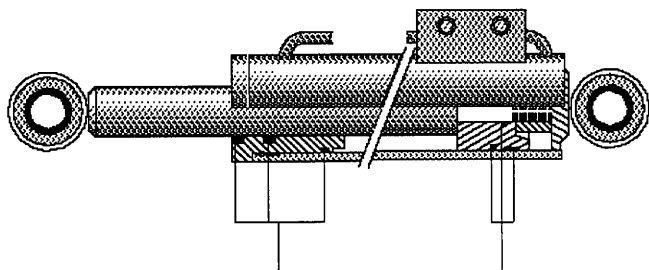

HEAD GLAND SEALS PISTON SEALS

Level Cylinder.

PLATFORM LEVELING PROCEDURE

After a platform level cylinder has been repaired or replaced, or if the platform does not remain level with the raising and lowering of the boom, the platform leveling circuit may need to be bled.



Assistance is required in order to perform the bleeding procedure. One person is needed to operate the platform level control, while the second person bleeds the system.

With all booms retracted, check the hydraulic fluid level in the tank. Slightly loosen the bleed nipple at the base of the leveling cylinder.



HYDRAULIC FLUID WILL BE FORCIBLY EJECTED FROM THE BLEED NIPPLE. LOOSEN NIPPLE SLOWLY.

With the platform near ground, operate the platform level control to move the platform fully backward and forward, repeating as necessary in order to expel any air from the system. Tighten the bleed nipple and top off the hydraulic tank. Repeat the procedure as required until all air is expelled.



CARE MUST BE TAKEN WHEN OPERATING LEVEL CONTROL. AIR IN CYLINDERS CAN CAUSE UNCONTROLLED PLATFORM MOTION.

After bleeding the leveling circuit, raise upper boom to full elevation and then fully lower boom. Check platform leveling operation.

SAFETY AND INSTRUCTIONAL LABELS

Insure that all safety and instruction labels are in place and legible. Refer to Parts Catalog for proper part number when ordering.

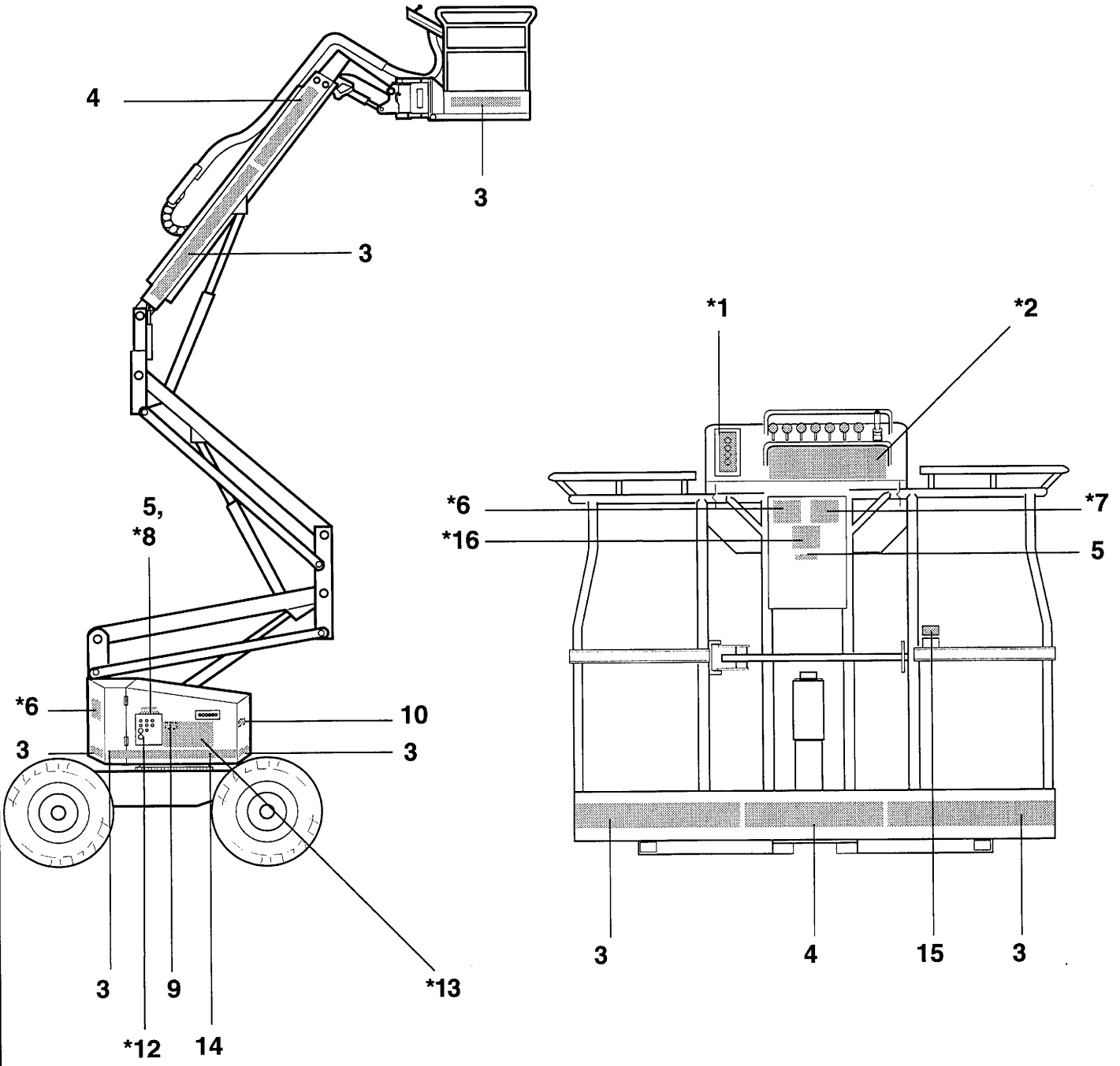

Index for decal location.

NOTE: asterisk indicates safety-related item.

- * 1 - Platform Control Panel Decal
- * 2 - Platform Control Lever Decal
- 3 - Stripe
- 4 - "Simon" Decal
- 5 - "Disengage Lockpin" Decal
- * 6 - "Beware, Potential Hazard" Decal
- * 7 - "Danger, Electrocution Hazard" Decal
- * 8 - "500 LBS Payload Capacity" Decal
- 9 - "Caution For Hydraulic Fluid Use Decal

- 10 - "Hydraulic Fluid Level Check" Decal
- 11 - Model Designation Decal
- * 12 - Ground Electrical Box Decal
- * 13 - Ground Control Operating Instructions
- 14 - "Constructor" Decal
- 15 - "120 VAC" Decal
- * 16 - "Platform Load" Decal

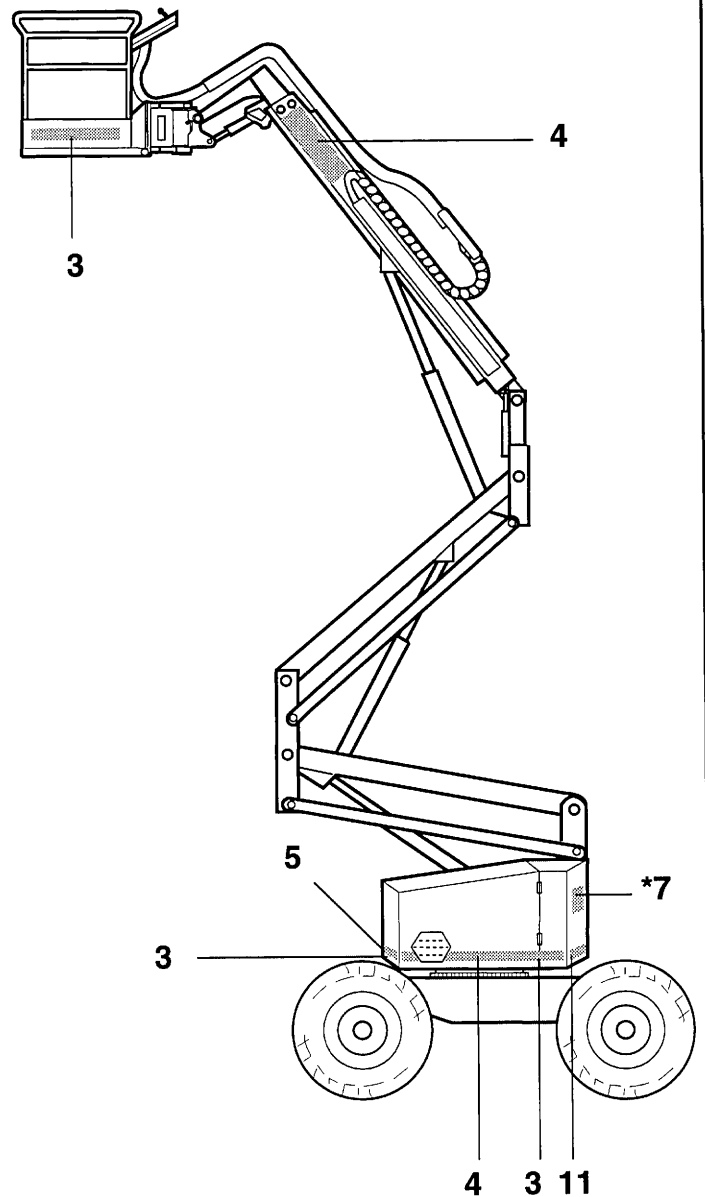
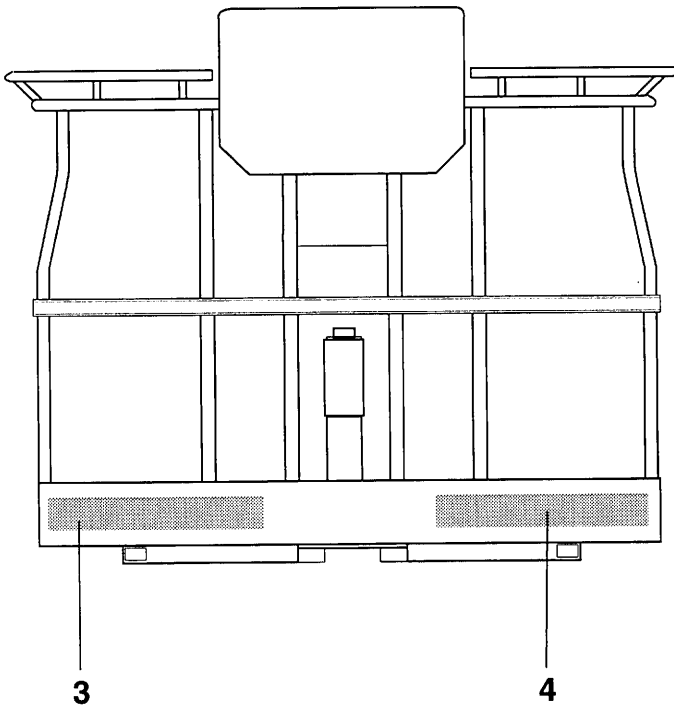

TROUBLESHOOTING

Before investigating a malfunction, check the following items:

- The ignition switch should be in the "ON" position.
- Be sure that fuel tank (or tanks) are not empty, and that engine is operating properly.
- The "Emergency Stop" buttons on both the ground and platform control panels should be released.
- The "Ground/ Platform" selector switch on the ground control panel should be at the correct setting.
- When attempting to operate any function (other than starting the engine) from the ground control panel, the "Power Control" switch must be held in clockwise position.
- When attempting to operate any function from the platform, the foot pedal on the platform floor must be depressed.
- Check that battery connections are secure and battery has sufficient charge.
- Hydraulic fluid should be at the correct level.
- Check that the 20 amp circuit breaker is not tripped.

Problem: Engine operates but pump does not generate hydraulic pressure.

Check that tank valves are in correct position.

Check hydraulic filters.

Check for hydraulic fluid leaks or low fluid level.

Examine pump assembly for mechanical defect.

Check pressure relief valve for correct pressure setting.

Check manifold.

Problem: Pump motor is slow in operation.

Check that the safe working load has not been exceeded.

Check pressure relief valve for correct pressure setting.

Verify that the correct grade of hydraulic fluid is being used.

Ensure engine is operating at correct speed.

Check electrical circuit for bad or loose connections.

Check pins and bushings for grease and proper fit.

Check needle valve operation.

Problem: Booms will not raise or lower.

Check for mechanical restrictions.

Check pressure relief valve for correct setting and pressure in function circuit.

Ensure engine is operating at correct speed.

Check for hydraulic fluid leaks.

Check holding valves for sticking or damage.

Check directional spools for proper movement.

Problem: Telescope boom will not operate.

Check pressure relief valve for correct pressure setting.

Inspect boom assembly for damage, or for obstruction between the inner and outer boom sections.

Check boom sliding surfaces for proper lubrication. Lubricate as necessary with silicone spray.

Check holding valves for sticking or damage.

Problem: Swing function does not operate.

Check for obstruction at the swing gearbox or swing bearing gear surfaces.

Inspect hydraulic swing motor and gearbox for proper operation.

The mechanical swing stop may be preventing rotation in one direction.

Problem: Machine steers sluggishly or not at all.

Check relief valve for correct pressure.

Check steer valve and solenoid for proper operation.

Inspect steer cylinder seals for leaks.

Check for loose or damaged steering linkage.

Examine electrical connections on steering control switch (thumb button located on drive control joystick).

Check axle king pins for proper lubrication.

Problem: Drive motor will not operate.

Ensure engine is operating at correct speed.

Check tank valves for correct position.

Check drive control system for proper actuator stroking pressure and proper stroke action.

Check hydrostatic pump charge pressure. If low, inspect suction filter and lines for restrictions. Inspect charge pump.

Check drive system pressure. Inspect accelerator valves and charge check valves in pump.

Verify that the brake is releasing.

Check drive pump neutral switch adjustment.

Check motor shift pressure.

Check limit switches for proper operation.

Problem: No "High Speed" operation.

Check control linkage and actuator.

Check drive pump.

Check neutral switch for proper adjustment.

Check drive system pressure.

Check drive pilot pressure.

Inspect boom limit switches for proper operation.

Refer to "Drive motor will not operate" problem, on previous page.

Problem: "High Speed" mode is available with booms elevated.

Check drive controller for proper operation.

Check low speed valve at manifold.

Inspect boom limit switches for proper operation.

Refer to "Drive motor will not operate" problem, on previous page.

Problem: "Emergency Stop" function does not work.

Check that the "Emergency Stop" button is operating correctly.

Check foot pedal switch for correct operation.

MAINTENANCE SCHEDULE

The Simon CONSTRUCTOR is designed to require a minimum amount of maintenance. However, it is essential that the specified services be performed at the indicated intervals, and that instructions contained in this manual are followed to ensure safety and reliability.

The hydraulic pumps, cylinders and pressure valves are self-lubricating.

The superstructure swing bearing is grease packed and should be greased monthly.

The corrosion resistant pivot pins and bearings require lubrication once every month.

Consult the accompanying engine manual for service and maintenance instructions specific to the engine supplied with each machine.

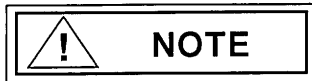

NOTE

As with any new machine, minor fluid leaks may occur until the various hydraulic components and pipe fittings are fully seated. It is particularly important that, for the first three months of operation, all hydraulic components, hoses and pipe fittings be checked regularly for leaks and tightness, and corrective action taken as required. Correction of minor fluid leaks and general tightening of machine components during this initial period are not considered as reimbursible expenses under the Simon Limited Warranty.

PIVOT PINS AND BEARINGS

All pivot points are equipped with grease "zerk" fittings. Under normal conditions, the pins should be lubricated after every 100 hours.

In tropical climates or other adverse conditions, pins and bearings may require more frequent lubrication.

GENERAL MAINTENANCE TIPS

Never leave components or hoses open. They must be protected from contamination (including rain) at all times.

Never open a hydraulic system or engine when there are contaminants in the air.

Use only recommended lubricants. Improper lubricants or incompatible lubricants may be as harmful as no lubrication.

ALWAYS clean the surrounding area before attempting to open hydraulic or engine systems.

Watch for makeshift "fixes", which can jeopardize safety as well as lead to more costly repairs.

Any work platform found not to be in safe operating condition should be removed from service until repaired. All repairs should be made by authorized personnel in conformance with the manufacturer's operating, maintenance and repair manuals.

ROUTINE SERVICING

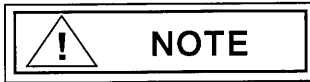

The following recommendations are based on the advice of suppliers, and the requirements of various safety regulations. They should be followed with discretion based on factors such as amount and type of machine usage, environmental conditions, and local safety regulations.

DAILY SERVICE

Hydraulic System

Before checking the hydraulic fluid level, ensure that the machine booms are stowed in the traveling position and the machine is standing on level ground. Fluid level must be one inch below the top of the level gauge. If the reservoir requires additional fluid, refer to the Lubrication Chart for the correct grade.

After checking the fluid level, ensure that the filler cap is secure to prevent entry of water or other impurities into the tank.

Pressurize the hydraulic circuit and inspect the system for any signs of fluid leakage, particularly at flexible hoses, connections and hydraulic components.

Check system operating pressure. Turn the engine on and, with boom in the stowed position, operate the lower boom control lever. Check the pressure gauge.

Check the pressure gauge on the filter assembly for indication that the element needs changing.

Check emergency pump pressure. Turn the engine off, then activate the emergency pump button. Check the pressure gauge while operating the lower boom control lever.

Machine Structure

Inspect entire machine for damage and condition of welds.

Tire Condition

Check that the machine tires are in good condition. Check tire pressure.

Wheel Lug Nuts

Check the wheel lug nuts for proper torque.

Platform Safety Gate

Check the security of the platform safety gate and latching mechanism.

Battery

Check battery terminals for corrosion and security.

Hose Track

Check hose track to verify it is not bent or sagging.

Pivot Pins

Examine all pivot pins on booms, cylinders and leveling system to ensure that they are positively secured in position.

Platform Leveling Cylinders

Examine both leveling cylinders, particularly at the pivot points, for any sign of wear or damage. Ensure that the pin retainers are secure.

Check cylinders and hose fittings for leaks.

Test All Machine Systems

Test the operation of the drive assembly, including drive shafts, transfer case, axles, couplings and gearbox. Check operating speeds.

Test the operation of the swing bearing, motor and gearbox.

Test the operation of the platform rotator.

Test the operation of all machine boom functions.

Engine

Check engine oil and fuel level. Check the engine manual provided with the machine for daily service requirements.

WEEKLY SERVICE

Control Valves

Platform and ground control valves must be checked for correct operation. Check that all control valve handles automatically return to the center (neutral) position.

Steering

Check the steering cylinder for fluid leakage. Inspect steering linkage for signs of wear.

Battery

Check the battery electrolyte level. Replenish the electrolyte with distilled water, if necessary.

Engine

Check the engine manual provided with the machine for weekly service requirements.

MONTHLY SERVICE

Hydraulic System

Allow the machine to stand overnight, or for at least eight hours, without operating the pump. This will allow water and any other impurities to separate out of the hydraulic fluid and settle to the bottom of the tank.

Disconnect the pipe from the pump side of the ball valve at the bottom of the tank, and block off to prevent fluid leakage from the system.

Open the ball valve just enough to allow a gradual trickle of fluid. Drain fluid from the tank into a transparent container, until clean hydraulic fluid flows. Under normal operating conditions, a maximum of one-half pint is usually sufficient to remove all impurities.

Check fluid color. If the hydraulic fluid does not flow clear amber, but has a cloudy appearance, it is usually an indication that water is present. A dark brown color, accompanied by a strong "burnt" smell, indicates that the fluid has overheated. If either condition occurs, a complete hydraulic fluid change will be necessary.

Check for hydraulic system leaks.

Chassis Bolts

Check all bolts for signs of looseness.

Axle

Torque bolts on axle mounting blocks. Check differential housing oil level. Top off as required.

Swing Bearing

Remove any dirt from between the swing bearing gear teeth and lubricate.



If solvents or a high-pressure washer are used for cleaning, grease the swing gear teeth, pinion and bearing.

Lubricate the swing gearbox top bearing with a quality bearing grease. Add grease through the fitting on the top center of the gearbox until grease comes out the purge port on top of the box.

Check torque of swing bearing bolts.

Swing Drive

Check swing drive adjustment. Check torque of swing drive mounting bolts.

Valve Spool Linkage

Clean and lubricate all valve spool linkage.

Pivot Pins

Examine all pivot pins on booms, cylinders and leveling system to ensure that they are positively secured in position.

Lubricate all pivot pins.

Transfer Case

Check transfer case lubricant level and top off as required to level of fill plug.

Drive

Check operation of low speed drive.

Check drive control pressure.

Drive Gearbox

Check drive gearbox oil level. Fill through case vent located on top of gearbox as necessary.

Engine

Check the engine manual provided with the machine for monthly service requirements.

SEMI-ANNUAL SERVICE

Hydraulic System

Have hydraulic fluid sample analyzed at a test laboratory.

Change both suction and return line filter elements.

Electrical System

Check electrical mounting and hardware for loose connections. Check for worn or broken wires.

Clean and lubricate all push button switches with an electrical contact cleaner, and ensure that the switches operate smoothly in all positions.

Axle

Drain and replace the oil in the differential housing.

Swing Drive

Drain and replace lubricant. If badly contaminated, disassemble and inspect components.

Check torque on upper frame, swing bearing and swing drive mounting bolts.

Transfer Case

Drain and replace lubricant. If badly contaminated, disassemble and inspect components.

Engine

Check engine low and high speed RPM settings.

Check the engine manual provided with the machine for semi-annual service requirements.

ANNUAL SERVICE

Swing Gear Bearings

Grease the swing gear bearing while rotating the superstructure as necessary to insure proper lubrication.

Hydraulic Fluid

If the hydraulic system has been properly maintained, the fluid should only need to be changed once each year. This, of course, will depend on machine application, amount of use, temperature, atmospheric conditions and other factors.

Hydraulic fluid, when in good condition, is clear amber in color. If the fluid has a cloudy appearance, this indicates the presence of water. If it is dark brown, with a strong "burnt" smell, overheating of the fluid has occurred. The presence of either condition requires a complete fluid change.

The cause of hydraulic fluid deterioration should be investigated and rectified. Have fluid analyzed by a qualified laboratory.

Hydraulic Fluid Tank

Carefully check the condition of the fluid inside the tank to ensure that it flows easily and is of clear, amber color. In cases of gross contamination, it will be necessary to completely drain and refill the entire hydraulic system.

When refilling the tank only, ensure that the fluid temperature is high enough to allow free flow. Place a suitable waste oil container under the drain tap, or attach a suitable hose from the drain tap to the container.

Open the drain tap and completely drain the fluid from the tank. Remove the tank top plate for internal inspection and cleaning.

Clean or replace the suction hose, and close the drain tap. Reinstall the tank top plate, replacing the gasket if necessary, and refill the tank to the correct level.

Flexible Hoses

Inspect all hoses over their complete length. Replace any hoses showing looseness or corrosion at the end fittings, cracking, blistering or excessive wear of outer protective covering.

Engine

Check the engine manual provided with the machine for annual service requirements.

FOUR YEAR INTERVAL SERVICE

Pivot Pins and Bearings

Remove the pivot pins for examination. Check the pivot pin bearings with the pivot pins removed. Replace as necessary with the correct type of pins and bearings.

DAILY OPERATIONAL CHECKLIST

All checks must be completed before operation of the CONSTRUCTOR.

MODEL NUMBER _____ INSPECTED BY _____

SERIAL NUMBER _____ DATE _____

- GENERAL INFORMATION:**
1. Keep inspection records up-to-date.
 2. Record and report all discrepancies to your supervisor.
 3. A dirty machine cannot be properly inspected.
- Keep your SIMON CONSTRUCTOR clean!!**



THIS CHECKLIST MUST BE USED DAILY. FAILURE TO DO SO COULD ENDANGER THE LIFE OF THE OPERATOR. ALWAYS REMEMBER, A LITTLE PREVENTIVE MAINTENANCE CAN SAVE MUCH MORE THAN IT COSTS.

<u>INITIAL</u>	<u>DESCRIPTION</u>
_____	1. Check unit for any prior shift or transportation damage, i.e. missing parts, torn or loose hoses, hydraulic oil leaks, torn or disconnected wires, flat or damaged tires etc. The compartment doors on both sides can be opened to inspect components inside.
_____	2. Check engine oil and fuel tank levels.
_____	3. Check engine coolant level (liquid cooled units only).
_____	4. Check battery electrolyte level and connections.
_____	5. Check hydraulic fluid level with all cylinders retracted. Fluid level should be to full mark on sight gauge.
_____	6. Check that wheel lug nuts are tightened to proper torque.
_____	7. Check tires for damage and proper inflation pressure.
_____	8. Check hoses for worn areas.
_____	9. Check for bent or sagging hose track.
_____	10. Check safety belts and connections.
_____	11. Check platform and gate for damage.
_____	12. Check pivot pins for security.
_____	13. Check warning and operating instruction decals for legibility.

DAILY OPERATIONAL CHECKLIST

INITIAL

DESCRIPTION

- | | |
|-------|---|
| _____ | 14. Start engine and check that hydraulic pressure is as stated on the data plate. |
| _____ | 15. Check that the drive interlock system has not been tampered with. |
| _____ | 16. Check pressure gauge on filter assembly. Replace filter element if gauge reads 20 PSI or higher. We recommend replacing both suction and return filter elements at the same time. |
| _____ | 17. After pre-inspection checks have been completed, check ground control station for proper operation (refer to "Ground Operation and Checks" in Operator's Manual). |
| _____ | 18. Check emergency pump for proper operation and hydraulic pressure as stated on Data Plate. |
| _____ | 19. Check platform controls for proper operation (refer to "Platform Operation and Checks" in Operator's Manual). |
| _____ | 20. With platform raised, check for smooth operation of low speed drive. |
| _____ | 21. Follow engine daily service requirements. Refer to the Engine Maintenance Manual supplied with your CONSTRUCTOR. |

ADDITIONAL MAINTENANCE REQUIREMENTS FOR SEVERE USAGE APPLICATIONS

INITIAL

DESCRIPTION

DAILY

- | | |
|-------|---|
| _____ | 22. Inspect cylinder boots, valve spool boots, etc., for cuts or other damage after every eight hours of service. Repair or replace if necessary. |
| _____ | 23. Check hydraulic system for leakage after every eight hours of operation. |

WEEKLY

- | | |
|-------|--|
| _____ | 24. Inspect condition of hydraulic fluid. Fluid should have a clear amber color. |
| _____ | 25. Lubricate all grease fittings. |
| _____ | 26. Apply dry lubricant to swing bearing and drive pinion gear. |

MONTHLY OPERATIONAL CHECKLIST

MODEL NUMBER _____ **INSPECTED BY** _____

SERIAL NUMBER _____ **DATE** _____

GENERAL INFORMATION:

1. Keep inspection records up-to-date.
 2. Record and report all discrepancies to your supervisor.
 3. A dirty machine cannot be properly inspected.
- Keep your SIMON CONSTRUCTOR clean!!**



THIS CHECKLIST MUST BE USED AT MONTHLY INTERVALS. FAILURE TO DO SO COULD ENDANGER THE LIFE OF THE OPERATOR. ALWAYS REMEMBER, A LITTLE PREVENTIVE MAINTENANCE CAN SAVE MUCH MORE THAN IT COSTS.

INITIAL

DESCRIPTION

1. Perform all checks listed on Daily Operational Checklist.
2. Lubricate all grease fittings (including those on drive shafts).
3. Inspect condition of hydraulic fluid in the tank. Oil should be a clear, amber color.
4. Check hydraulic system for leaks. Examine hoses for signs of excessive wear, chafing or twisting. Replace worn hoses if necessary.
5. Inspect the work platform and boom structure for damage and condition of welds.
6. Check the low speed drive to ensure it is within specified limits.
7. Check operation of emergency pump.
8. Check all decals for legibility.
9. Clean and lubricate all valve controls so they do not stick.
10. Check joints, linkage pins and retaining bolts for security.
11. Check tires for cracks and other damage.
12. Check for unit damage, broken welds, improper or makeshift repairs.
13. Torque nuts on eight axle mounting U-bolts.
14. Check rubber wrap around hoses at moving anchor, telescope boom, support posts, boom hose passages and at swing bearing.

MONTHLY OPERATIONAL CHECKLIST

INITIAL

DESCRIPTION

- | | |
|-------|--|
| _____ | 15. Check boom hose carrier for sag and other damage. If damaged; repair, and correct the cause of damage, i.e. hoses too tight, breaking cross braces and worn, cracked or abraded hoses. |
| _____ | 16. Check torque of swing bearing bolts (see "Machine Specifications"). |
| _____ | 17. Check adjustment and security of swing drive. There should be a slight amount of backlash between the superstructure and undercarriage when properly adjusted. |
| _____ | 18. Check oil level in swing drive. It should be half filled. |
| _____ | 19. Check oil level in both axles, speed reducer and transfer case. (Refer to Lubrication Chart.) |
| _____ | 20. Follow engine monthly service requirements. Refer to the Engine Maintenance Manual supplied with your CONSTRUCTOR. |

ADDITIONAL MAINTENANCE REQUIREMENTS FOR SEVERE USAGE APPLICATIONS

INITIAL

DESCRIPTION

90 DAYS

- | | |
|-------|---|
| _____ | 21. Change suction and return filter elements. |
| _____ | 22. Change engine oil and filter, and follow all other engine severe usage service requirements. Refer to the Engine Maintenance Manual supplied with your CONSTRUCTOR. |

SEMI - ANNUAL OPERATIONAL CHECKLIST

MODEL NUMBER _____

INSPECTED BY _____

SERIAL NUMBER _____

DATE _____

GENERAL INFORMATION:

- 1. Keep inspection records up-to-date.
 - 2. Record and report all discrepancies to your supervisor.
 - 3. A dirty machine cannot be properly inspected.
- Keep your SIMON CONSTRUCTOR clean!!**



THIS CHECKLIST MUST BE USED AT 6 MONTH INTERVALS. FAILURE TO DO SO COULD ENDANGER THE LIFE OF THE OPERATOR. ALWAYS REMEMBER, A LITTLE PREVENTIVE MAINTENANCE CAN SAVE MUCH MORE THAN IT COSTS.

INITIAL

DESCRIPTION

- 1. Perform all checks listed on Daily and Monthly Operational Checklists.
- 2. Have hydraulic fluid sample analyzed at a test laboratory. Follow the recommendations of test results.



If hydraulic fluid has been regularly maintained, it should only require changing once every year, depending on maintenance, temperature, application, duty cycle, and atmospheric conditions.

- 3. Inspect the entire machine for signs of damage and broken welds.
- 4. Check operating speeds to ensure they are within specified limits.
- 5. Check operation of emergency power system.

6. Check all decals for legibility.

7. Clean and lubricate all pushbutton switches with an electrical contact cleaner and ensure that the switches operate freely in all positions.

8. Check all electrical mounting and hardware connections for security.

9. Check that engine RPM is as stated on Data Plate.

10. Replace both suction and return filter elements.

11. Check tightness of upper frame, swing bearing and swing drive mounting bolts.

SEMI - ANNUAL OPERATIONAL CHECKLIST

INITIAL	DESCRIPTION
_____	12. Drain and replace fluid from swing drive, axles, speed reducer and transfer case. If badly contaminated, it may be necessary to disassemble and inspect components.
_____	13. Inspect entire machine for worn or damaged components. Replace as necessary.
_____	14. Lubricate all hydraulic valve spool linkages.
_____	15. Lubricate swing bearing and drive pinion gear.
_____	16. Tune engine and follow all other engine semi-annual service requirements. Refer to the Engine Maintenance Manual supplied with your CONSTRUCTOR.

ADDITIONAL MAINTENANCE REQUIREMENTS FOR SEVERE USAGE APPLICATIONS

INITIAL	DESCRIPTION
_____	17. Replace fuel filter and follow all other engine severe usage service requirements. Refer to the Engine Maintenance Manual supplied with your CONSTRUCTOR.

MAINTENANCE CHART



This Maintenance Chart is only to be used as a reminder of the detailed instructions given in this manual. All detailed servicing instructions must be implemented.

Maintenance Item	Daily	Weekly	Monthly	Semi-Annual	Annual	4 Year
Check machine structure	X					
Check platform structure	X					
Check boom structure	X					
Check unit for broken welds	X					
Check tire condition	X					
Check tire pressure	X					
Check wheel lug nuts	X					
Check hose track	X					
Check platform door latch	X					
Check pivot pin security	X					
Check battery terminals	X					
Check engine oil level	X					
Check fuel level	X					
Check engine coolant level	X					
Check pressure gauge on filter assembly	X					
Check hydraulic fluid level	X					
Check hydraulic pressure	X					
Inspect hydraulic system	X					
Check low speed drive	X					
Check platform leveling	X					
Check emergency pump operation	X					
Test all machine systems	X					
Check battery electrolyte		X				

MAINTENANCE CHART

Maintenance Item	Daily	Weekly	Monthly	Semi-Annual	Annual	4 Year
Check control valves		X				
Check steering system		X				
Check for tangled hoses			X			
Check chassis bolts			X			
Check moving anchor			X			
Check boom/cylinder pins			X			
Check torque on swing bearing bolts			X			
Torque bolts on axle mounting blocks			X			
Check drive gearbox fluid			X			
Check swing gearbox fluid level			X			
Check axles and transfer case fluid level			X			
Check hydraulic fluid contamination			X			
Lubricate all grease fittings			X			
Clean and lubricate valve controls			X			
Grease swing gear teeth			X			
Lubricate pivot pins			X			
Check engine RPM				X		
Replace fuel filter				X		
Engine tune-up				X		
Check platform mountings				X		
Check boom gland nuts				X		
Check swing drive mounting bolts				X		
Check electrical system				X		

MAINTENANCE CHART

Maintenance Item	Daily	Weekly	Monthly	Semi-Annual	Annual	4 Year
Check operating speeds				X		
Replace swing drive, axles and transfer case fluid				X		
Replace suction and return filter elements				X		
Clean and lubricate push button switches				X		
Lubricate hydraulic valve control linkages				X		
Analyze hydraulic fluid				X		
Check pivots for wear					X	
Check hoses for wear					X	
Change hydraulic fluid					X	
Grease swing bearings					X	
Examine pivot pins						X
Examine bearings						X

ELECTRICAL AND HYDRAULIC SCHEMATICS

HYDRAULIC SCHEMATICS:

MODEL AT30C WITH WHEEL BRAKES	REF. DWG. NO. SDS-218173-0
MODEL AT40C WITHOUT WHEEL BRAKES	REF. DWG. NO. SDS-216324-0
MODEL AT40C WITH WHEEL BRAKES (TYPE 1) ..	REF. DWG. NO. SDS-216899-0
MODEL AT40C WITH WHEEL BRAKES (TYPE 2) ..	REF. DWG. NO. SDS-217350-0

DEUTZ F2L511 (DIESEL):

MODEL AT40C ELECTRICAL SCHEMATIC	REF. DWG. NO. SDS-216339-0
ENGINE WIRING DIAGRAM	REF. DWG. NO. SDS-216340-0 (SHEET 1 AND 2)

FORD VSG 413 (DUAL FUEL):

MODEL AT40C ELECTRICAL SCHEMATIC	REF. DWG. NO. SDS-231603-0
--	----------------------------

ISUZU 3KC1 (DIESEL):

MODEL AT40C ELECTRICAL SCHEMATIC (TYPE 1)	REF. DWG. NO. SDS-217065-0
ENGINE WIRING DIAGRAM (TYPE 1)	REF. DWG. NO. SDS-217066-0 (SHEET 1 AND 2)
MODEL AT40C ELECTRICAL SCHEMATIC (TYPE 2)	REF. DWG. NO. SDS-217351-0
ENGINE WIRING DIAGRAM (TYPE 2)	REF. DWG. NO. SDS-217461-0 (SHEET 1 AND 2)
MODEL AT40C ELECTRICAL SCHEMATIC (TYPE 2)	REF. DWG. NO. SDS-219818-0 (SHEET 1 AND 2)

KUBOTA (DUAL FUEL):

MODEL AT40C ELECTRICAL SCHEMATIC	REF. DWG. NO. SDS-217106-0
ENGINE WIRING DIAGRAM	REF. DWG. NO. SDS-217107-0 (SHEET 1)
	REF. DWG. NO. SDS-216457-0 (SHEET 2)
MODEL AT40C ELECTRICAL SCHEMATIC	REF. DWG. NO. SDS-219819-0
ENGINE WIRING DIAGRAM	REF. DWG. NO. SDS-219820-0 (SHEET 1 AND 2)

ONAN (GASOLINE):

MODEL AT40C ELECTRICAL SCHEMATIC WITH WHEEL BRAKES	REF. DWG. NO. SDS-216352-0
ENGINE WIRING DIAGRAM	REF. DWG. NO. SDS-216351-0 (SHEET 1 AND 2)
MODEL AT40C ELECTRICAL SCHEMATIC	REF. DWG. NO. SDS-219821-0
ENGINE WIRING DIAGRAM	REF. DWG. NO. SDS-219822-0 (SHEET 1 AND 2)

ELECTRICAL AND HYDRAULIC SCHEMATICS CONTINUED

ONAN (DUAL FUEL):

MODEL AT40C ELECTRICAL SCHEMATIC WITHOUT WHEEL BRAKES	REF. DWG. NO. SDS-216353-0
ENGINE WIRING DIAGRAM	REF. DWG. NO. SDS-216348-0 (SHEET 1 AND 2)
MODEL AT40C ELECTRICAL SCHEMATIC WITH WHEEL BRAKES	REF. DWG. NO. SDS-214178-0
ENGINE WIRING DIAGRAM	REF. DWG. NO. SDS-216348-0 (SHEET 1)
ENGINE WIRING DIAGRAM	REF. DWG. NO. SDS-216354-0 (SHEET 2)
MODEL AT40C ELECTRICAL SCHEMATIC	REF. DWG. NO. SDS-219823-0
ENGINE WIRING DIAGRAM	REF. DWG. NO. SDS-219824-0 (SHEET 1 AND 2)

PERKINS (DIESEL):

MODEL AT30/40C ELECTRICAL SCHEMATIC	REF. DWG. NO. SDS-217516-0
ENGINE WIRING DIAGRAM	REF. DWG. NO. SDS-217503-0 (SHEET 1 AND 2)
ENGINE WIRING DIAGRAM	REF. DWG. NO. SDS-219825-0 (SHEET 1 AND 2)

WISCONSIN 30 H.P. (GASOLINE):

MODEL AT40C ELECTRICAL SCHEMATIC	REF. DWG. NO. SDS-216331-0
ENGINE WIRING DIAGRAM	REF. DWG. NO. SDS-216330-0 (SHEET 1)
	REF. DWG. NO. SDS-216330-02 (SHEET 2)
MODEL AT40C ELECTRICAL SCHEMATIC	REF. DWG. NO. SDS-219826-0
ENGINE WIRING DIAGRAM	REF. DWG. NO. SDS-219827-0 (SHEET 1 AND 2)

WISCONSIN 30 H.P. (DUAL FUEL):

MODEL AT40C ELECTRICAL SCHEMATIC	REF. DWG. NO. SDS-216329-0
ENGINE WIRING DIAGRAM	REF. DWG. NO. SDS-216457-0 (SHEET 1 AND 2)
MODEL AT40C ELECTRICAL SCHEMATIC	REF. DWG. NO. SDS-219828-0
ENGINE WIRING DIAGRAM	REF. DWG. NO. SDS-219912-0 (SHEET 1 AND 2)

WISCONSIN 35 H.P. (DUAL FUEL):

ELECTRICAL SCHEMATIC	REF. DWG. NO. SDS-230700-0 (SHEET 1 AND 2)
----------------------------	---

WISCONSIN 35 H.P. (GAS):

ELECTRICAL SCHEMATIC	REF. DWG. NO. SDS-230701-0
----------------------------	----------------------------

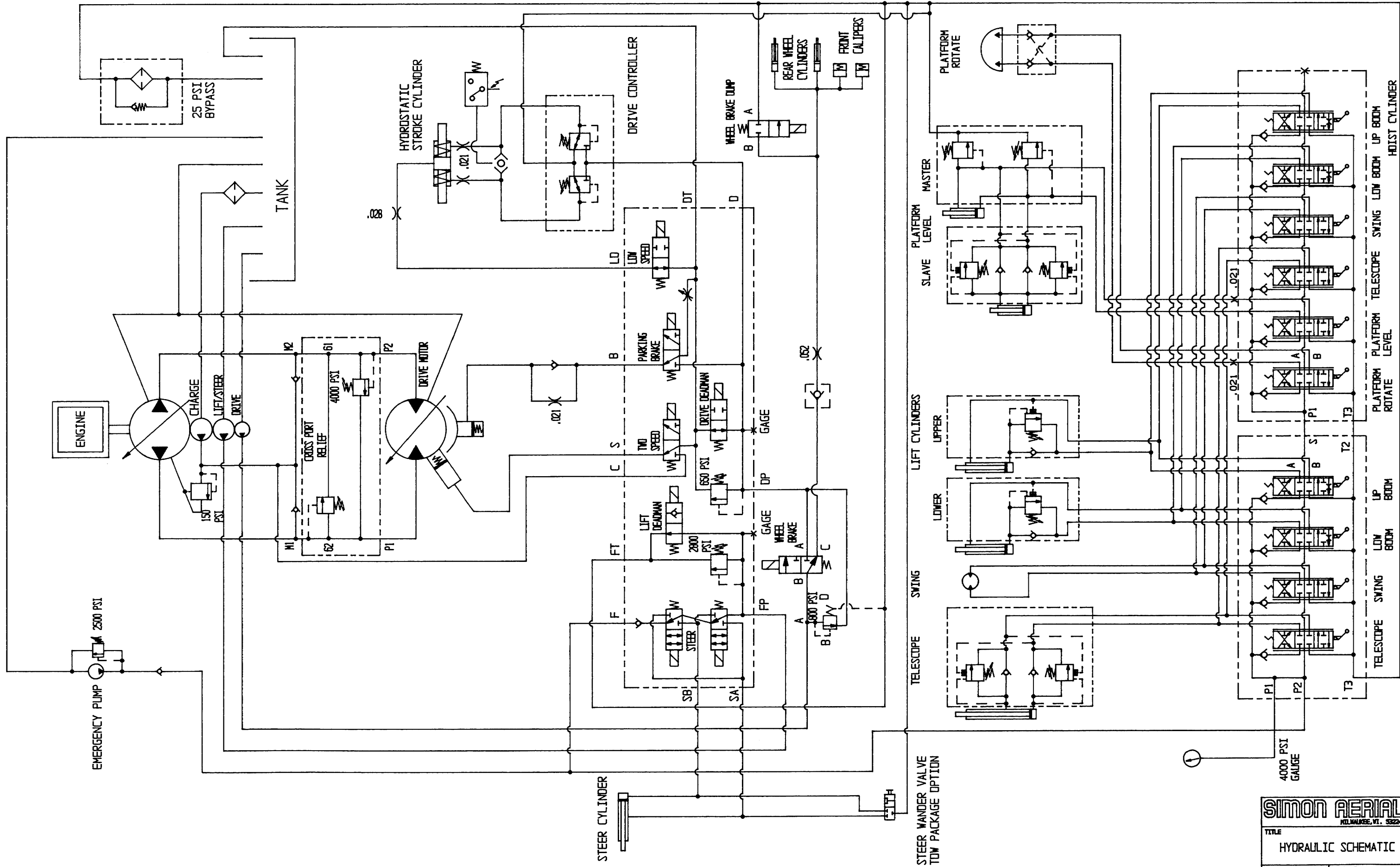

SIMON AERIALS INC.	
REMARKS: P. 8824	
TITLE HYDRAULIC SCHEMATIC / AT30C	
REVISION A	DRWG. NO. SDS-218173-0

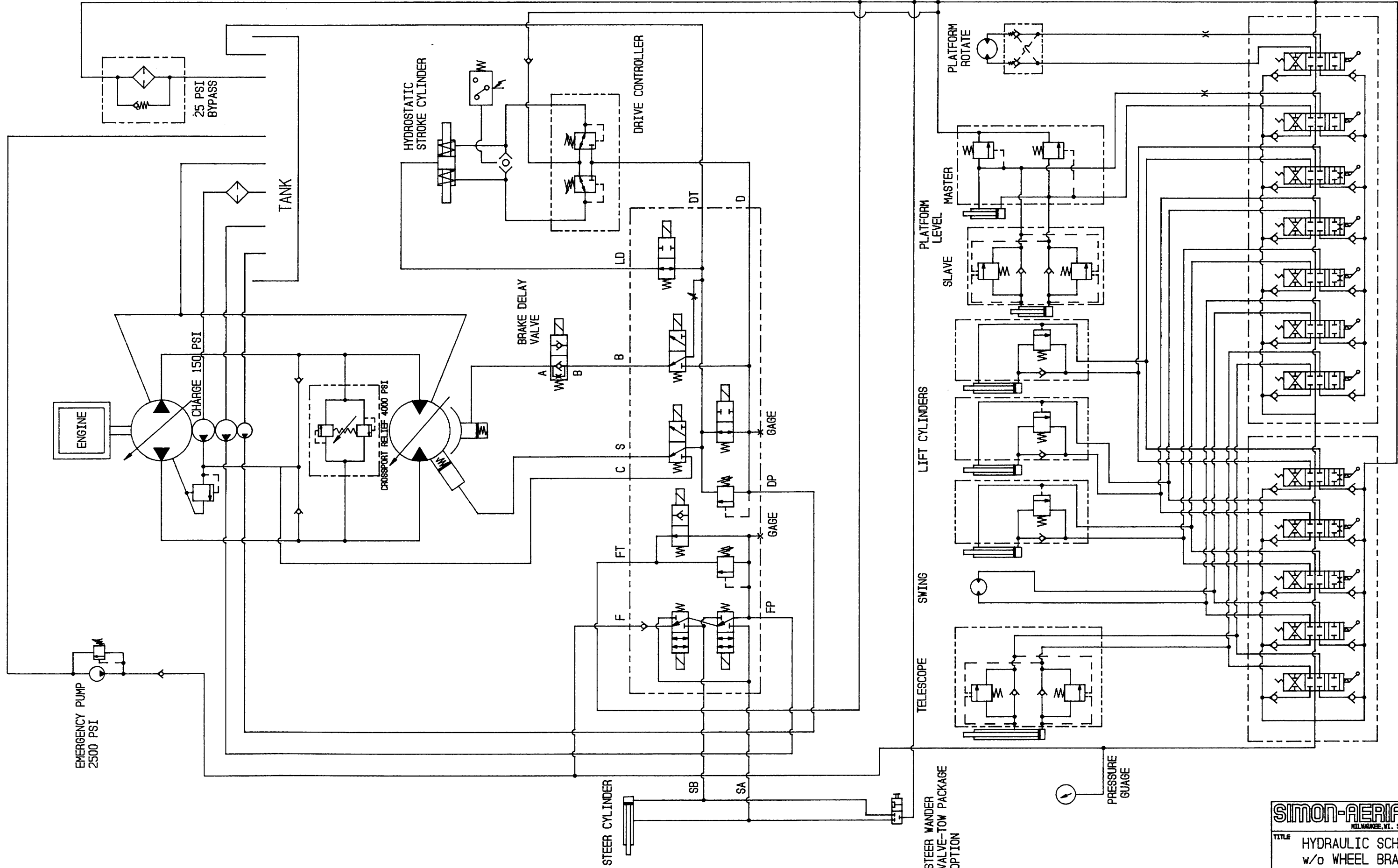

SIMON-AERIALS INC.
 MILWAUKEE, WI. 53224

TITLE: HYDRAULIC SCHEMATIC
 w/o WHEEL BRAKES AT40C

REVISION: DRAW. NO. SDS-216324-0

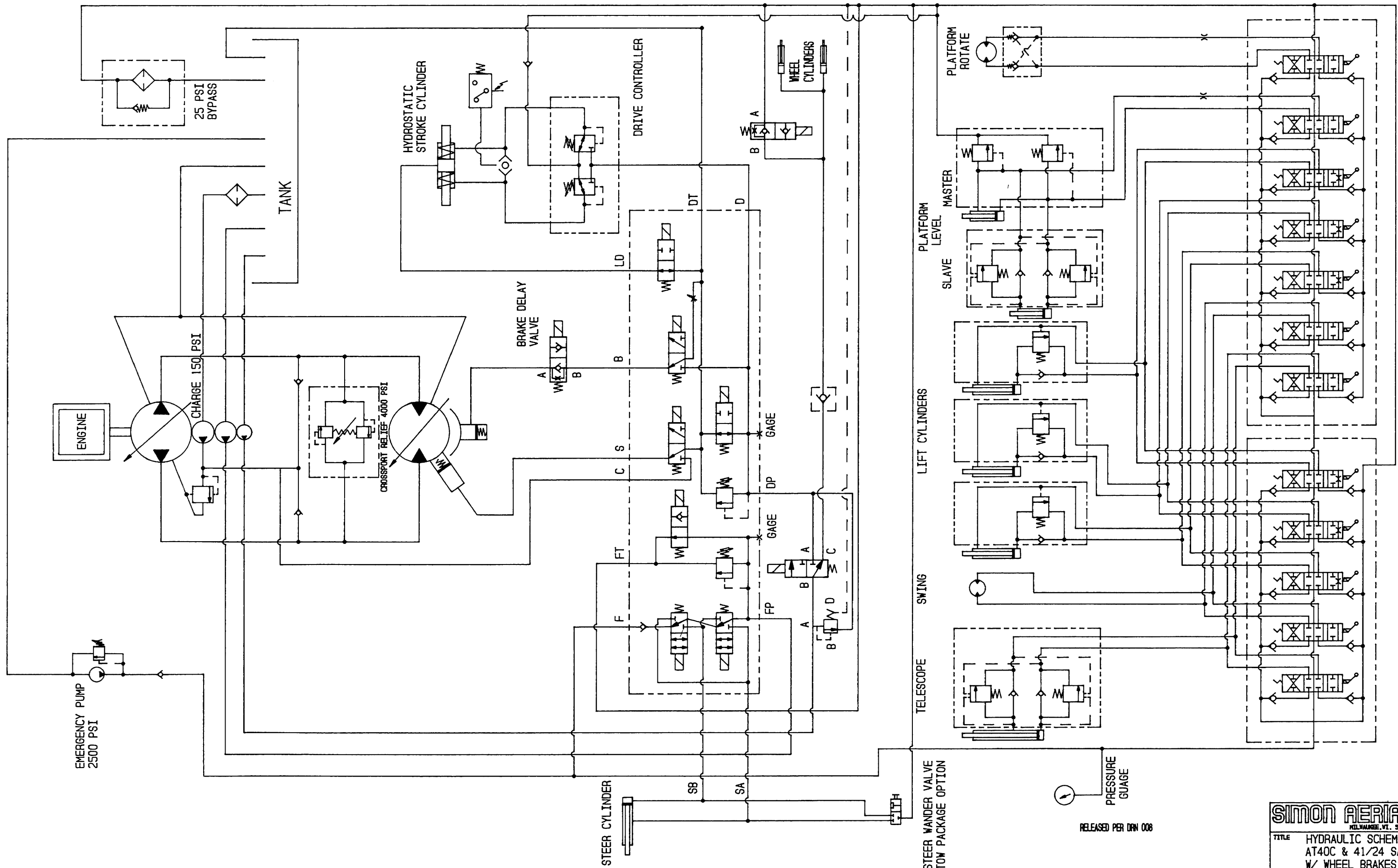

EMERGENCY PUMP
2500 PSI

CHARGE 150 PSI

CROSSPORT RELIEF 4000 PSI

25 PSI BYPASS

TANK

HYDROSTATIC STROKE CYLINDER

STEER CYLINDER

DRIVE CONTROLLER

STEER WANDER VALVE
TOW PACKAGE OPTION

TELESCOPE

SWING

LIFT CYLINDERS

PLATFORM LEVEL

SLAVE

MASTER

PLATFORM ROTATE

WHEEL CYLINDERS

PRESSURE GAUGE

RELEASED PER DRN 008

1216 005

GROUND VALVE BANK

PLATFORM VALVE BANK

SIMON AERIALS INC.
MILWAUKEE, WI. 53224

TITLE HYDRAULIC SCHEMATIC
AT40C & 41/24 SAI EAGLE
W/ WHEEL BRAKES

REVISION _____ DRWG. NO. SDS-216899-0

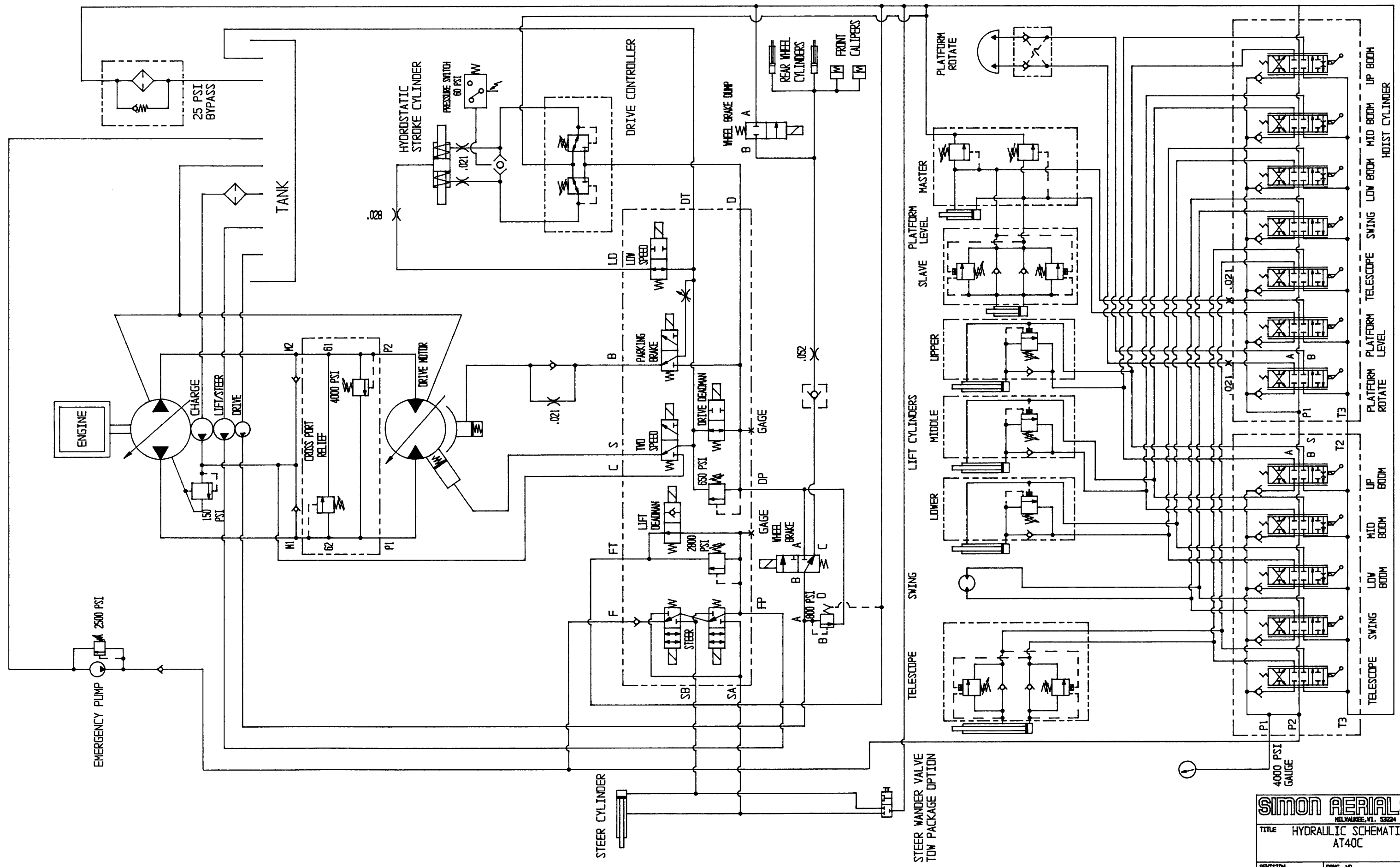

SIMON AERIALS INC.	
REL. VALVE, #1: 5824	
TITLE HYDRAULIC SCHEMATIC AT40C	
REVISION D 05-06-92	DRWG. NO. SDS-217350-0

GROUND VALVE BANK

PLATFORM VALVE BANK

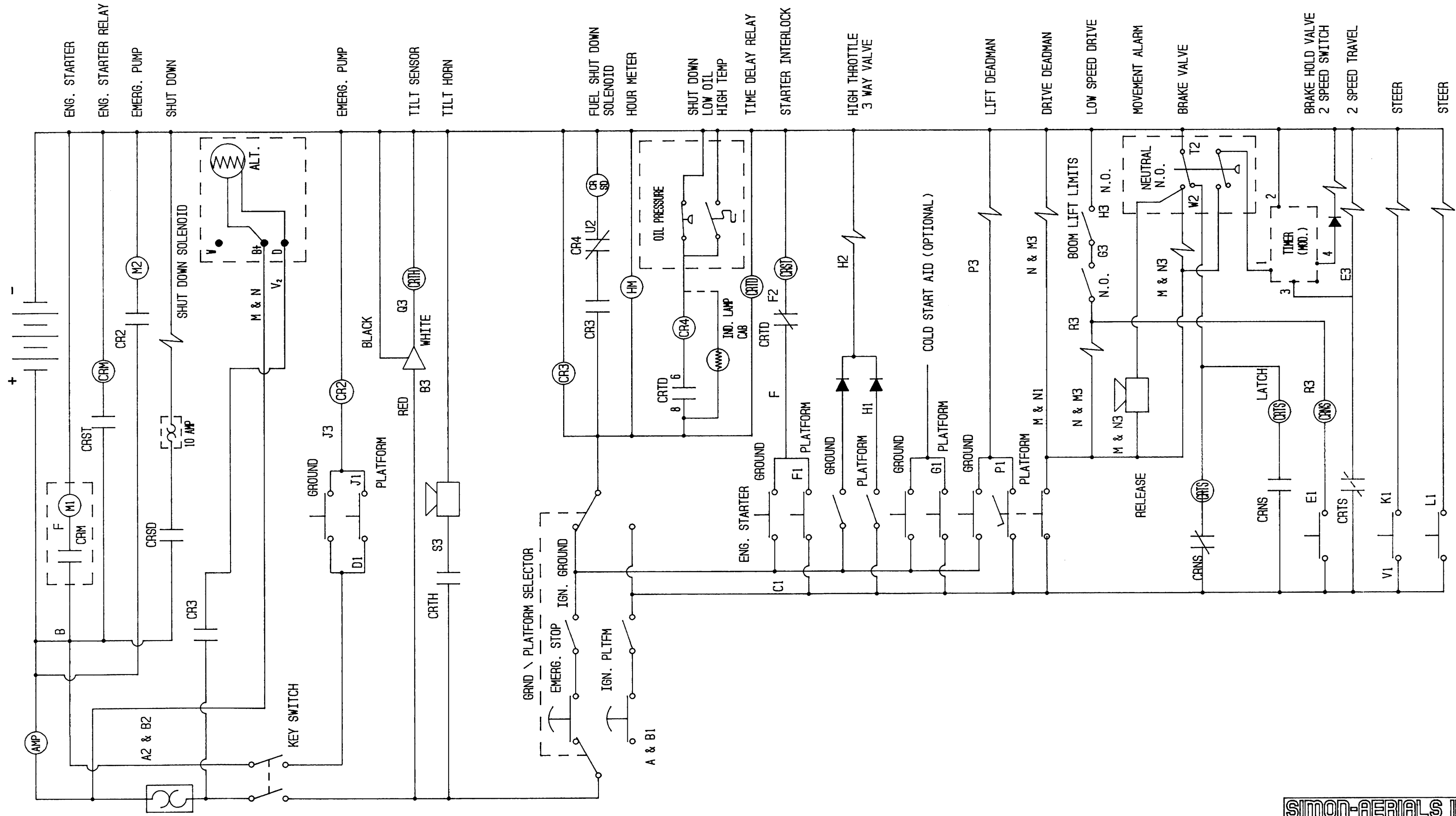

- ENG. STARTER
- ENG. STARTER RELAY
- EMERG. PUMP
- SHUT DOWN
- EMERG. PUMP
- TILT SENSOR
- TILT HORN
- FUEL SHUT DOWN SOLENOID
- HOUR METER
- SHUT DOWN LOW OIL HIGH TEMP
- TIME DELAY RELAY
- STARTER INTERLOCK
- HIGH THROTTLE 3 WAY VALVE
- LIFT DEADMAN
- DRIVE DEADMAN
- LOW SPEED DRIVE
- MOVEMENT ALARM
- BRAKE VALVE
- BRAKE HOLD VALVE
- 2 SPEED SWITCH
- 2 SPEED TRAVEL
- STEER
- STEER

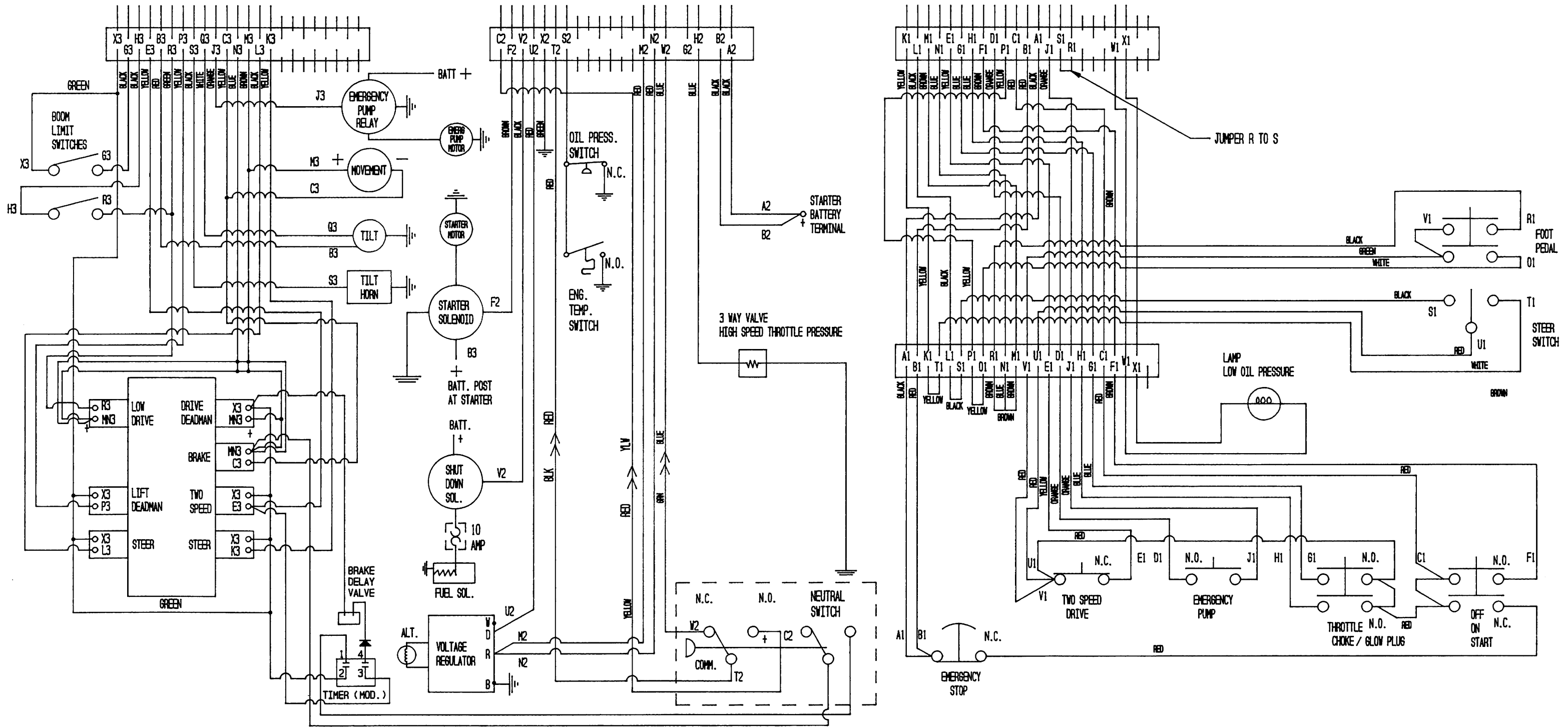

19 CONDUCTOR CONNECTION AT GRD BOX

CONN. LTR	WIRE NO.	COLOR
A	1	BLK
B	2	RED
C	7	RED/BLK
D	4	ORNG
E	5	YLV
F	6	BRN
G	3	BLUE
H	8	BLUE/BLK
J	9	ORNG/BLK
K	10	YLV/BLK
L	12	BLK/RED
M	11	BRN/BLK
N	13	BLUE/RED
O	PLUG	
P	15	YLV/RED
Q	14 (SPARE)	ORNG/RED
R	18	
S	19	
T	PLUG	
U	PLUG	
V	PLUG	
W	16	BRN/RED
X	17	BLK/BLU

19 CONDUCTOR CONNECTION AT PLATFORM

CONN. LTR	WIRE NO.	COLOR
A	1	BLK
B	2	RED
C	7	RED/BLK
D	4	ORNG
E	5	YLV
F	6	BRN
G	3	BLUE
H	8	BLUE/BLK
J	9	ORNG/BLK
K	10	YLV/BLK
L	12	BLK/RED
M	11	BRN/BLK
N	13	BLUE/RED
O	FOOT SW	WHT
P	15	YLV/RED
Q	14 (SPARE)	ORNG/RED
R	FOOT SW	BLK
S	STEER SW	BLK
T	STEER SW	WHT
U	STEER SW	RED
V	STEER SW	GRN
W	FOOT SW	BRN/RED
X	16	BLK/BLU

SIMON-REIALS INC.
MILWAUKEE, WI. 53224

TITLE: WIRING DIAGRAM
AT40C / DEUTZ F2L511

REV. 8/10
DWG. NO. SDS-216340-0

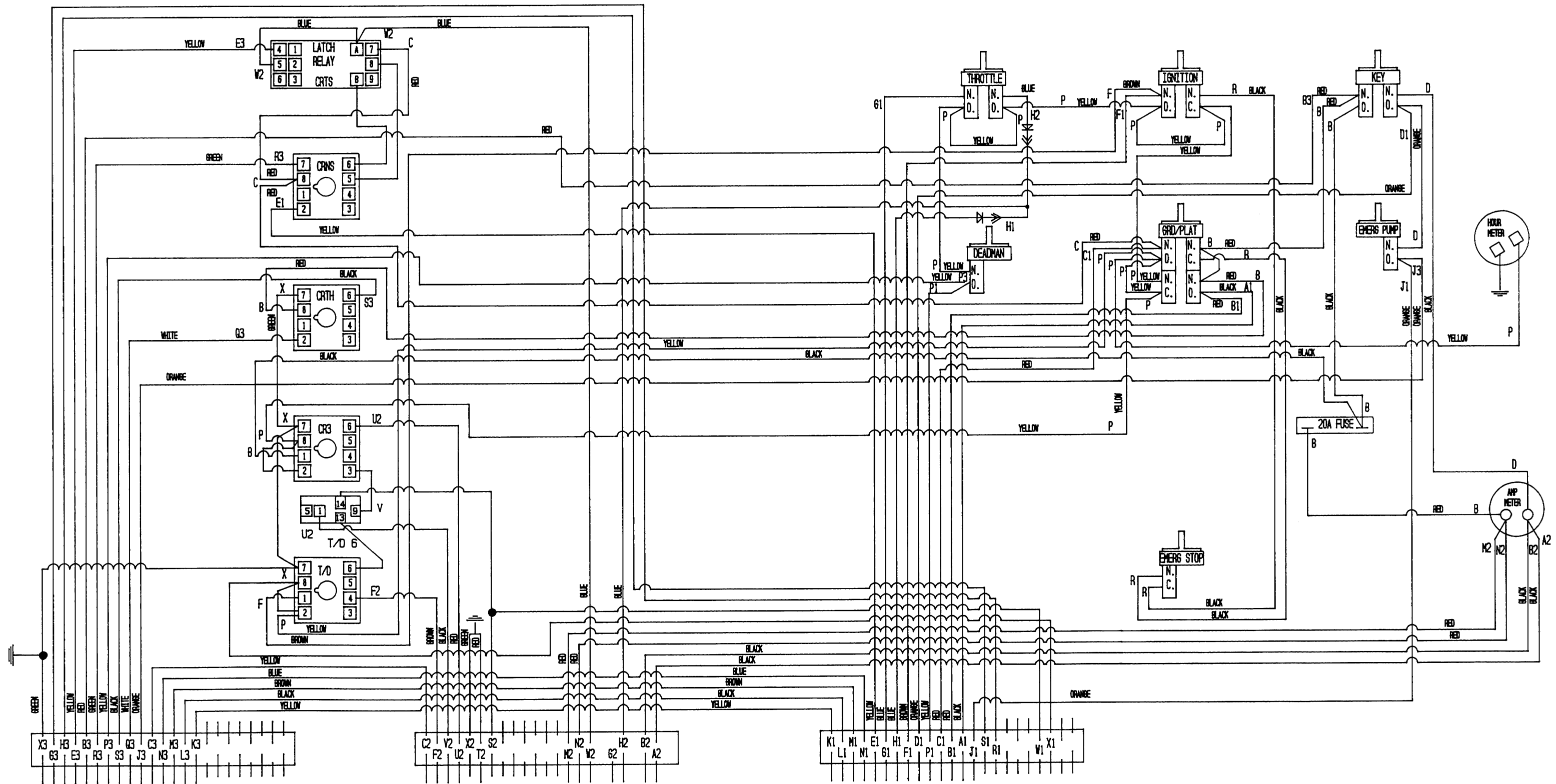

SIMON-AERIALS INC.
 KILLBUCK, VT. 53224

TITLE: WIRING DIAGRAM
 AT40C / DEUTZ F2L511

REVISION: _____ DRAW. NO.: SDS -216340-0

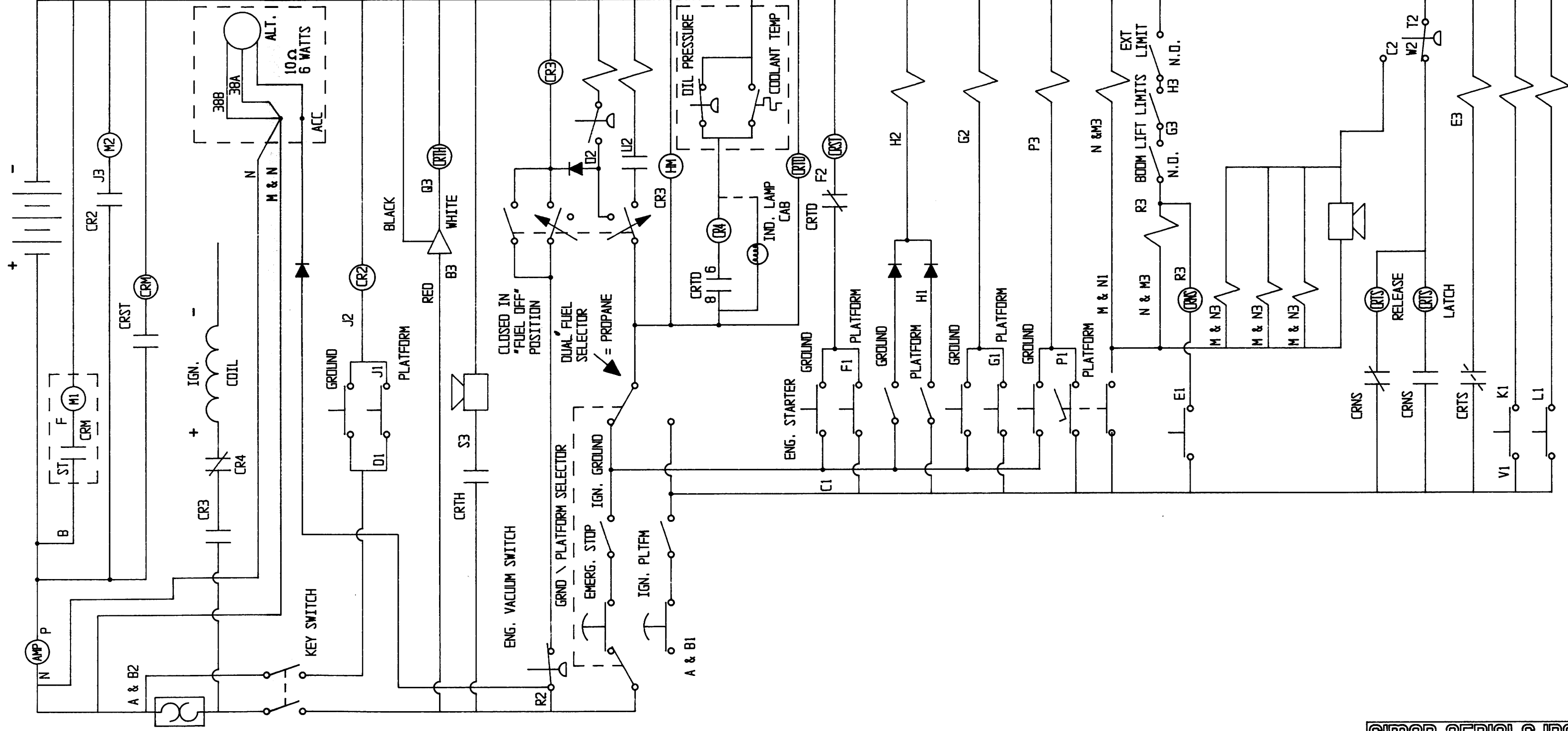

ENG. STARTER
EMERG. PUMP
STARTER SOLENOID

EMERG. PUMP

TILT SENSOR
TILT HORN

IGN. (SOURCE)
GAS SHUT-OFF & ANTI-DIESEL
PROPANE SHUT-OFF
HOUR METER

SHUT DOWN
LOW OIL / HIGH TEMP.
TIME DELAY RELAY
STARTER INTERLOCK

HIGH THROTTLE
(3 WAY VALVE)

CHOKE SOLENOID

LIFT DEADMAN

DRIVE DEADMAN

LOW SPEED DRIVE

2 SPEED SWITCH

WHEEL BRAKE DUMP

BRAKE VALVE

BRAKE VALVE PARKING

MOVEMENT ALARM

NEUTRAL SWITCH

2 SPEED TRAVEL

STEER

STEER

SIMON-AERIALS INC.
MELANBEE, VT. 05224

TITLE
ELECTRICAL SCHEMATIC
DUAL FUEL FORD
(VSG-413) AT40C

REVISION
DRWG. NO.
SDS-2316030

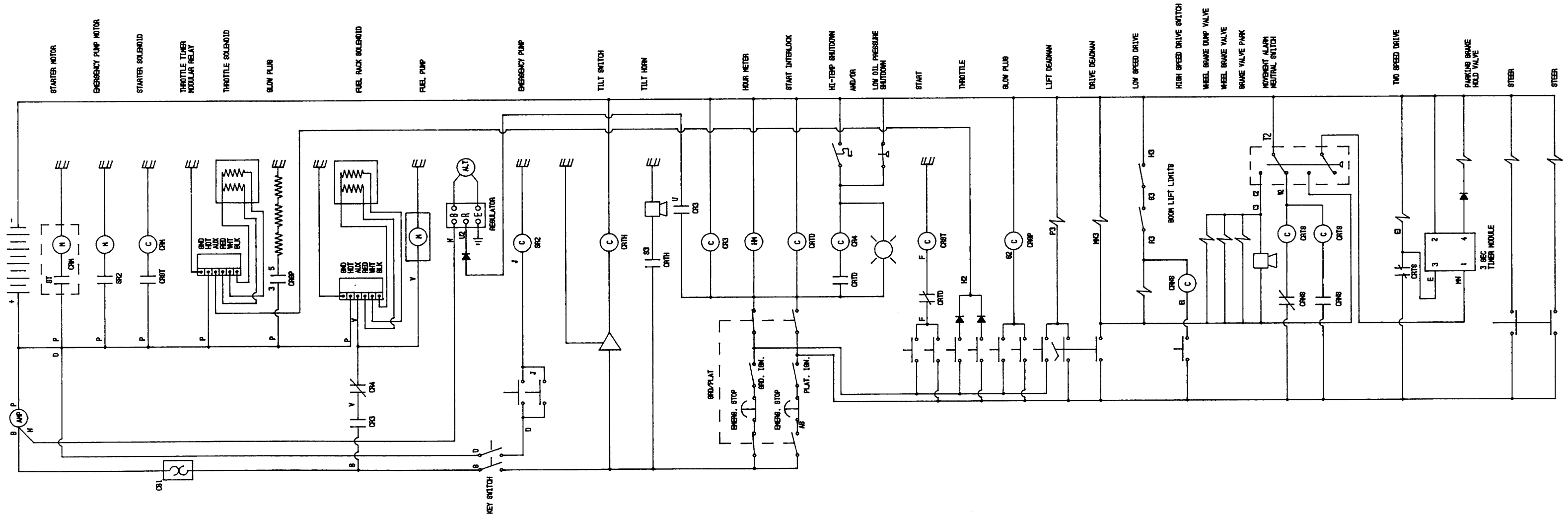

SIMON-AERIALS INC. MILWAUKEE, WI. 53224	
TITLE ELECTRICAL SCHEMATIC AT40C & 41/24 EAGLE ISUZU	
REVISION	DRWG. NO. SDS-217065-0

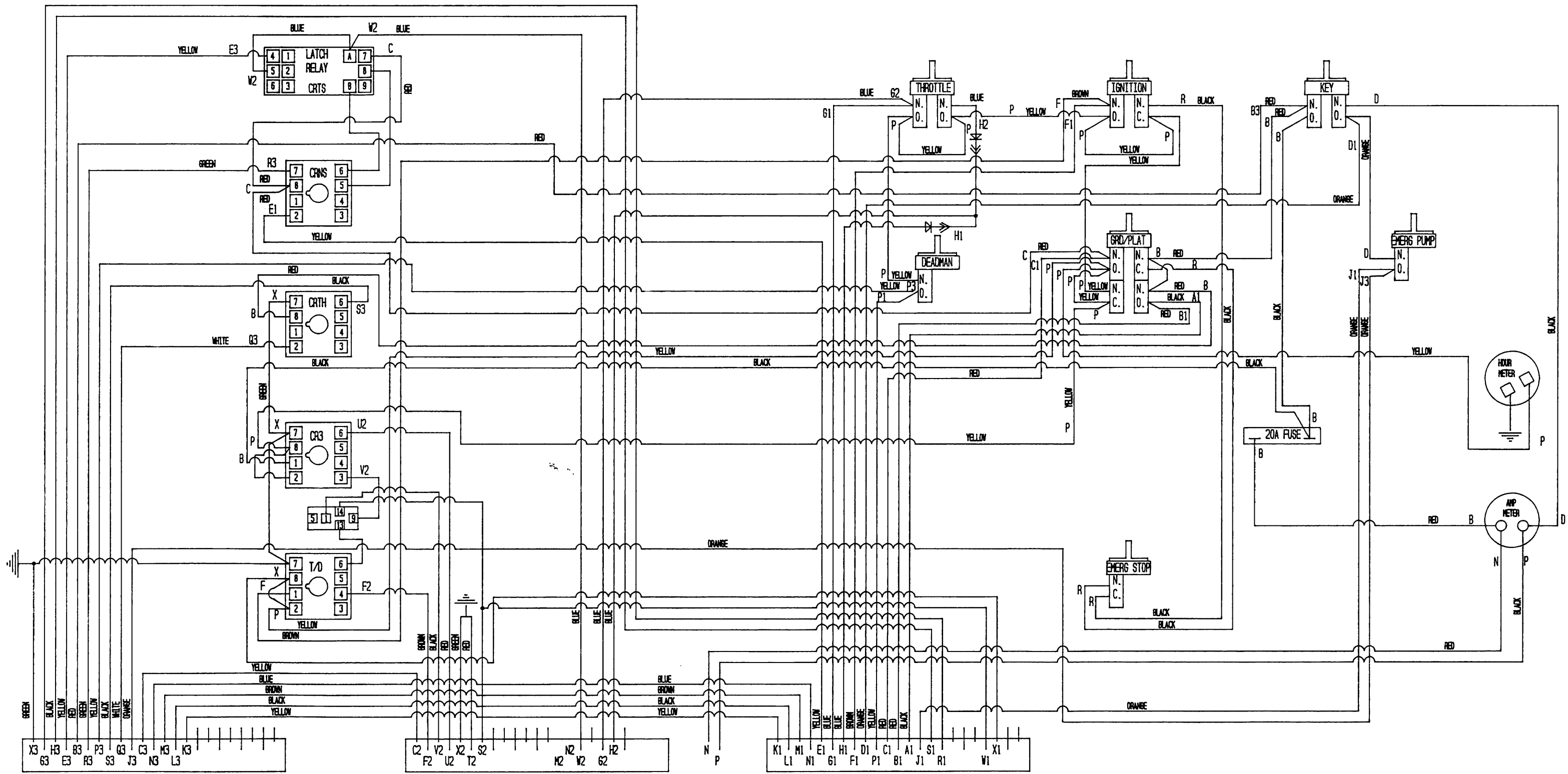

WIRE COLORS:
 GREEN
 BLACK
 YELLOW
 RED
 WHITE
 ORANGE
 BLUE
 BROWN

SIMON-AERIALS INC.
 MILWAUKEE, WI. 53224

TITLE: WIRING DIAGRAM
 ISUZU AT40 & EAGLE 41/24

REVISION: ORG. NO. SDS-217066-0

JUN 26 1990

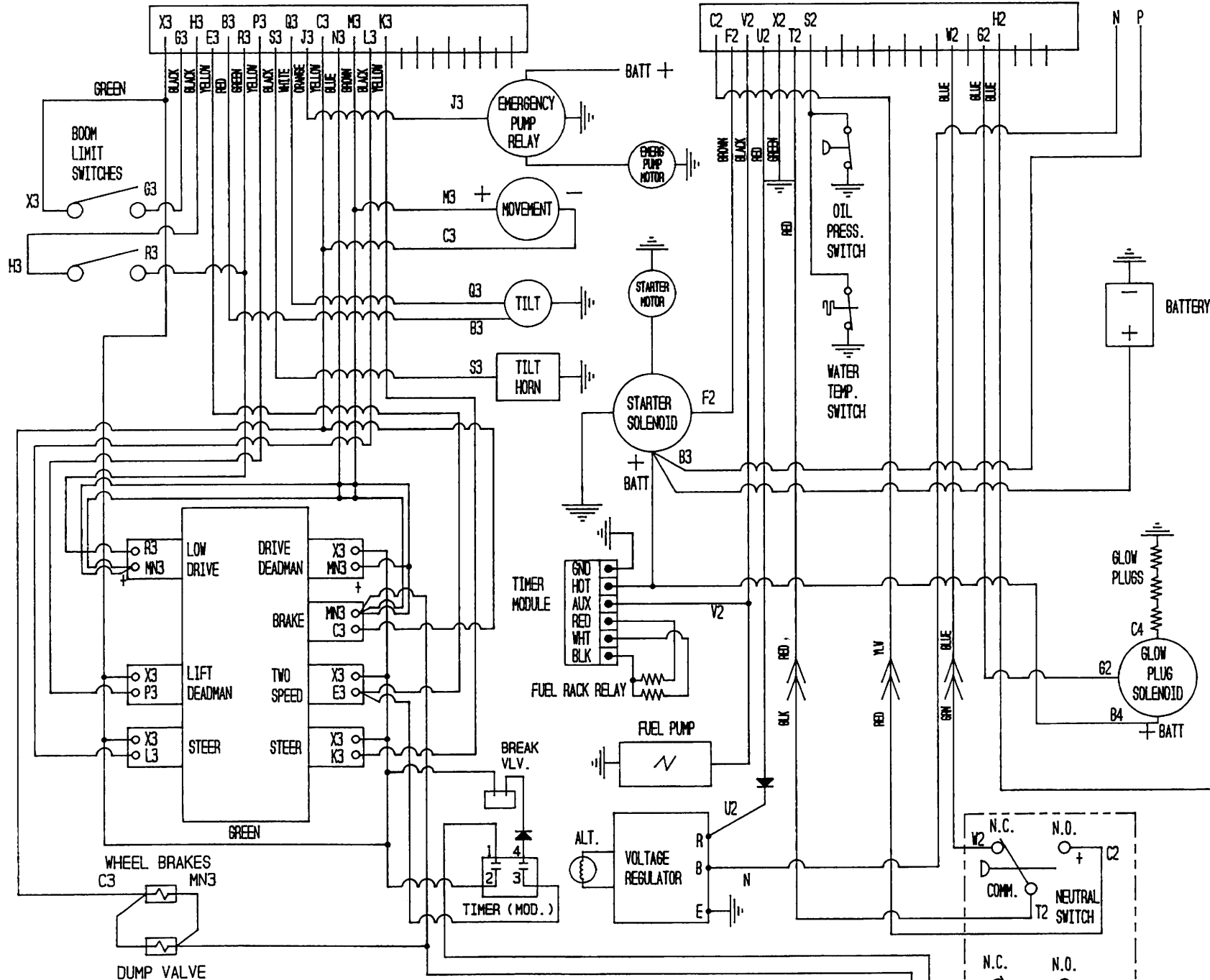

19 CONDUCTOR CONNECTIONS AT GROUND BOX

CONN. LETTER	WIRE NO.	COLOR
A	1	BLACK
B	2	RED
C	3	RED/BLACK
D	4	ORANGE
E	5	YELLOW
F	6	BROWN
G	7	BLUE
H	8	BLUE/BLACK
J	9	ORANGE/BLACK
K	10	YELLOW/BLACK
L	11	BLACK/RED
M	12	BROWN/BLK
N	13	BLUE/RED
O	14	YELLOW/RED
P	15	ORANGE/RED
Q	16	BROWN/RED
R	17	BLACK/BLUE

19 CONDUCTOR CONNECTIONS AT PLATFORM

CONN. LETTER	WIRE NO.	COLOR
A	1	BLACK
B	2	RED
C	3	RED/BLACK
D	4	ORANGE
E	5	YELLOW
F	6	BROWN
G	7	BLUE
H	8	BLUE/BLACK
J	9	ORANGE/BLACK
K	10	YELLOW/BLACK
L	11	BLACK/RED
M	12	BROWN/BLK
N	13	BLUE/RED
O	14	YELLOW/RED
P	15	ORANGE/RED
Q	16	BLACK
R	17	BLACK
S	18	STEER SWITCH
T	19	STEER SWITCH
U	20	STEER SWITCH
V	21	STEER SWITCH
W	22	STEER SWITCH
X	23	STEER SWITCH

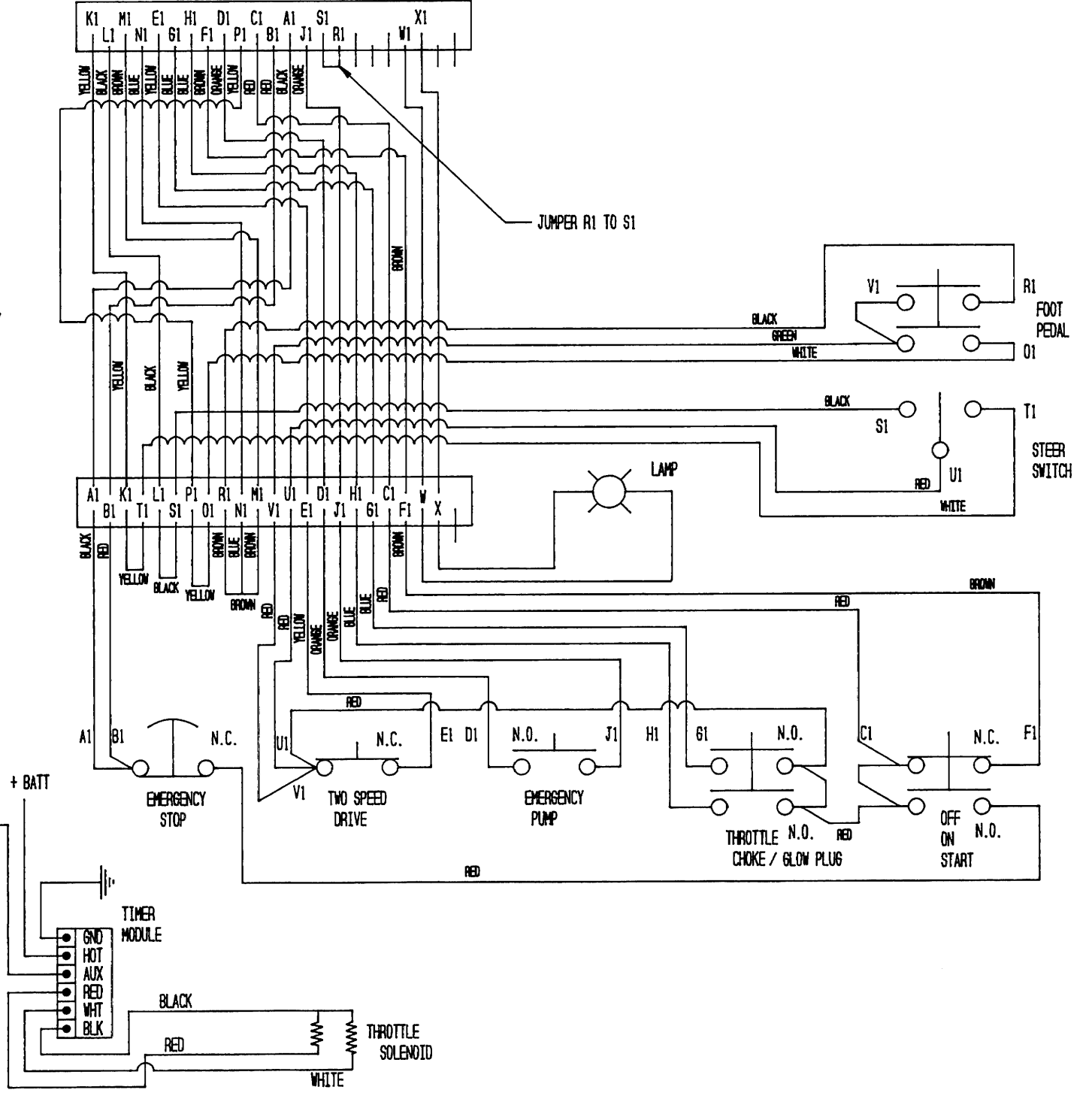

SIMON-AERIALS INC.
 KILLWAUKEE, WIS. 53224

TITLE: WIRING DIAGRAM
 ISUZU AT40 & EAGLE 41/24

REVISION: DRWG. NO. SDS-217066-0

JUN 26 1990

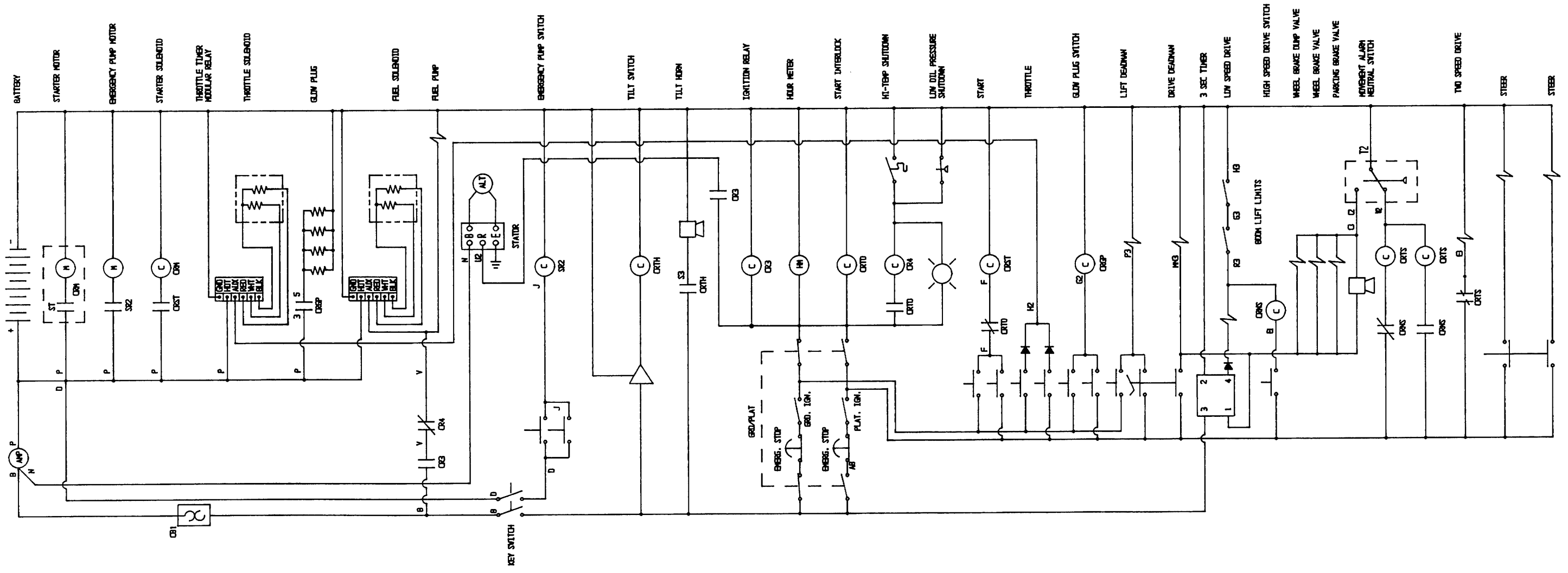

SIMON-AERIALS INC.
MILWAUKEE, WI. 53224

TITLE
ELECTRICAL SCHEMATIC
AT30C/AT40C-ISUZU 3KCI

REVISION
C 01-04-91

DRWG. NO.
SDS-217351-0

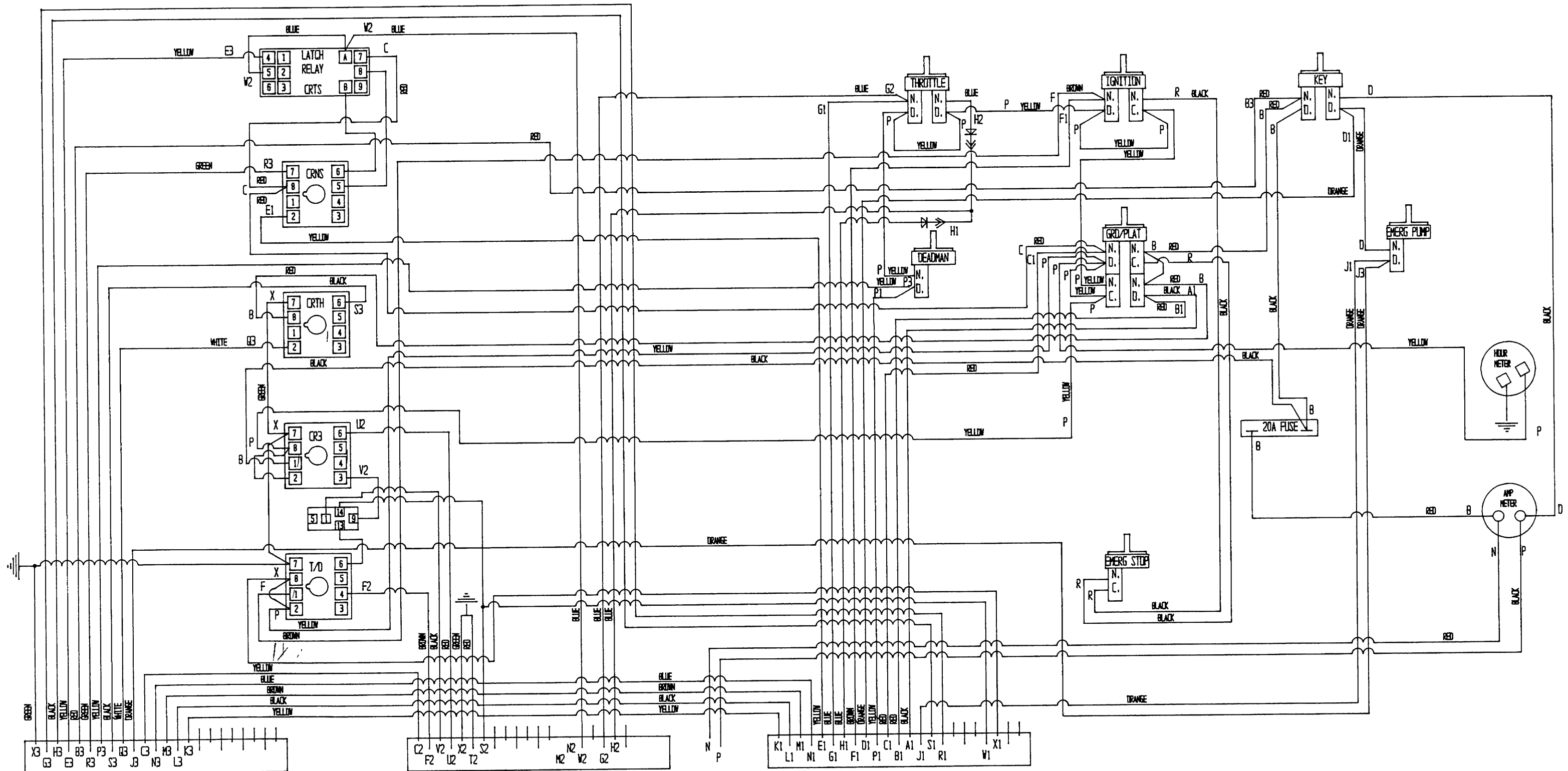

WIRE COLORS:
 GREEN
 BLACK
 YELLOW
 RED
 WHITE
 ORANGE
 BLUE
 BROWN

SIMON-AERIALS INC.
 MILWAUKEE, WI. 53224

TITLE: WIRING DIAGRAM
 AT30/AT40 ISUZU 3KCI

REVISION: _____ DWG. NO.: SDS-217461

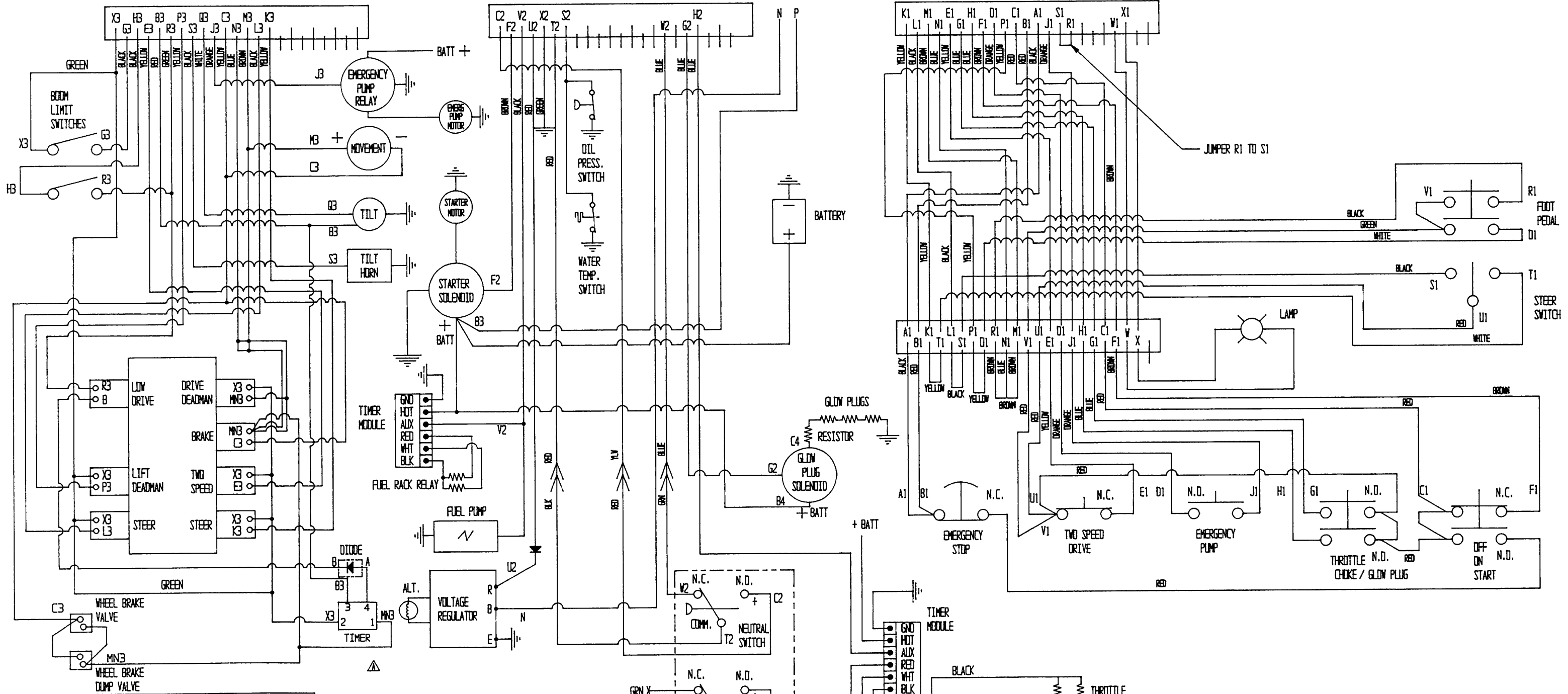

19 CONDUCTOR CONNECTIONS AT GROUND BOX

CONN. LETTER	WIRE NO.	COLOR
A	1	BLACK
B	2	RED
C	3	RED/BLACK
D	4	ORANGE
E	5	YELLOW
F	6	BROWN
G	7	BLUE
H	8	BLUE/BLACK
J	9	ORANGE/BLACK
K	10	BLACK/RED
L	11	BROWN/BLACK
M	12	BROWN/BLK
N	13	BLUE/RED
O	14	YELLOW/RED
P	15	ORANGE/RED
Q	16	BROWN/RED
R	17	YELLOW/RED
S	18	ORANGE/RED
T	19	BROWN/RED
U	20	BLACK/RED
V	21	RED
W	22	BROWN/RED
X	23	BLACK/BLUE

19 CONDUCTOR CONNECTIONS AT PLATFORM

CONN. LETTER	WIRE NO.	COLOR
A	1	BLACK
B	2	RED
C	3	RED/BLACK
D	4	ORANGE
E	5	YELLOW
F	6	BROWN
G	7	BLUE
H	8	BLUE/BLACK
J	9	ORANGE/BLACK
K	10	BLACK/RED
L	11	BROWN/BLACK
M	12	BROWN/BLK
N	13	BLUE/RED
O	14	YELLOW/RED
P	15	ORANGE/RED
Q	16	BLACK
R	17	BLACK
S	18	WHITE
T	19	WHITE
U	20	RED
V	21	RED
W	22	BROWN/RED
X	23	BLACK/BLUE

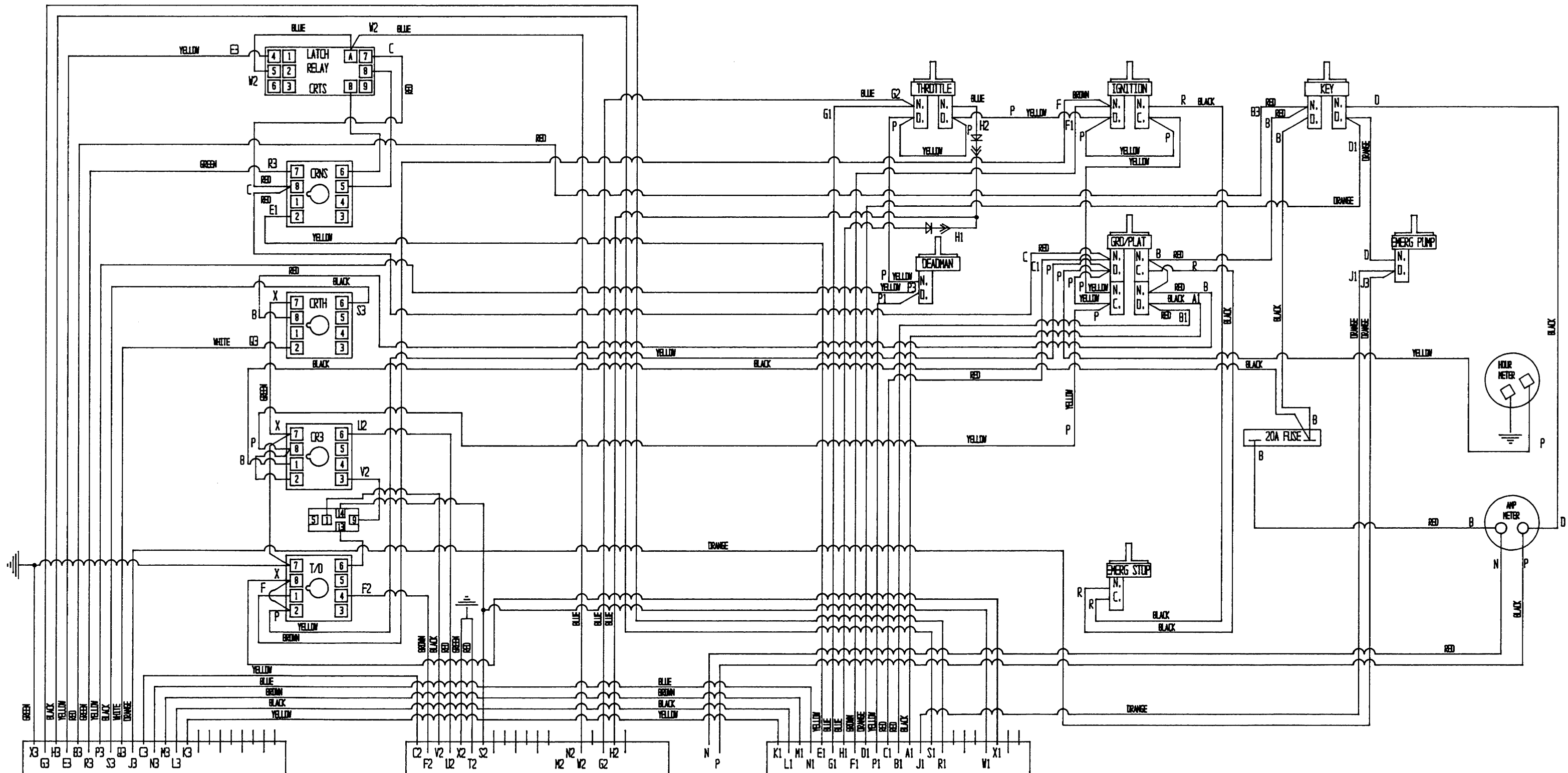

WIRE COLORS:
 GREEN
 BLACK
 YELLOW
 RED
 WHITE
 ORANGE
 BLUE
 BROWN

SIMON AERIALS INC.
 MILWAUKEE, WI. 53224

TITLE: ELECTRICAL SCHEMATIC
 AT30/AT40 ISUZU EKCI

REVISION: DRWG. NO. SDS-219818-0

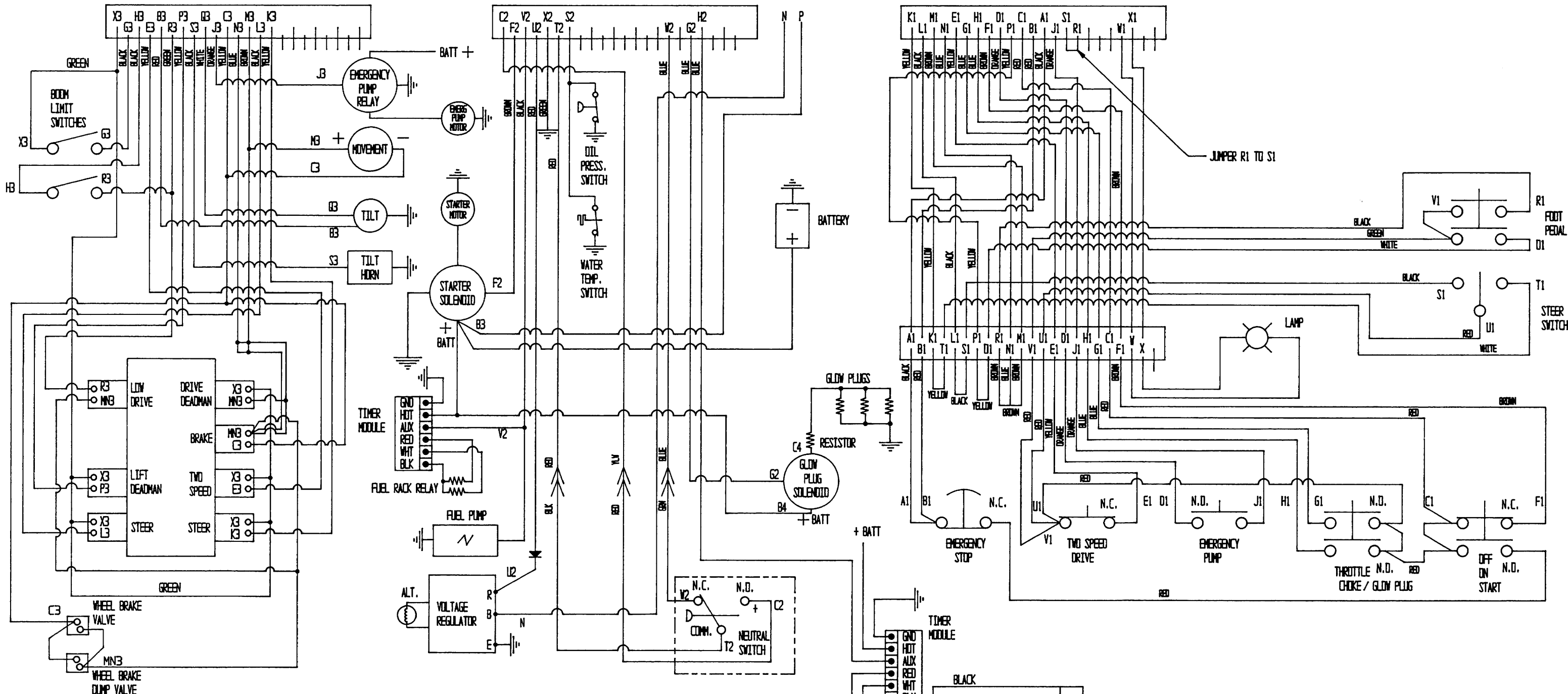

19 CONDUCTOR CONNECTIONS AT GROUND BOX

CONN. LETTER	WIRE NO.	COLOR
A	1	BLACK
B	2	RED
C	7	RED/BLACK
D	4	ORANGE
E	5	YELLOW
F	6	BROWN
G	3	BLUE
H	8	BLUE/BLACK
J	9	ORANGE/BLACK
K	10	YELLOW/BLACK
L	12	BLACK/RED
M	11	BROWN/VLK
N	13	BLUE/RED
O	PLUG	
P	15	YELLOW/RED
R	PLUG	
S	PLUG	
T	PLUG	
U	PLUG	
V	PLUG	
W	16	BROWN/RED
X	17	BLACK/BLUE

19 CONDUCTOR CONNECTIONS AT PLATFORM

CONN. LETTER	WIRE NO.	COLOR
A	1	BLACK
B	2	RED
C	7	RED/BLACK
D	4	ORANGE
E	5	YELLOW
F	6	BROWN
G	3	BLUE
H	8	BLUE/BLACK
J	9	ORANGE/BLACK
K	10	YELLOW/BLACK
L	12	BLACK/RED
M	11	BROWN/VLK
N	13	BLUE/RED
O	PLUG	
P	15	YELLOW/RED
R	PLUG	
S	PLUG	
T	PLUG	
U	PLUG	
V	PLUG	
W	16	BROWN/RED
X	17	BLACK/BLUE

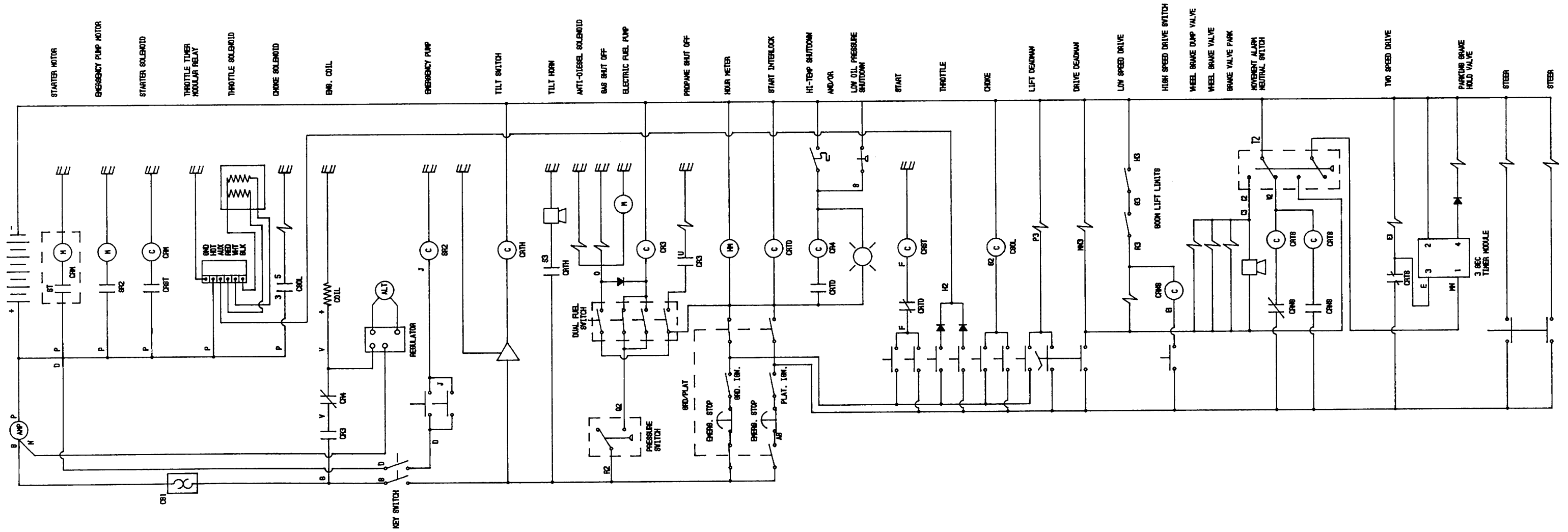

SIMON-AERIALS INC. MILWAUKEE, WI. 53224	
TITLE	ELECTRICAL SCHEMATIC AT40C P224 ONAN GAS.
REVISION	DRWG. NO. SDS-217106-0

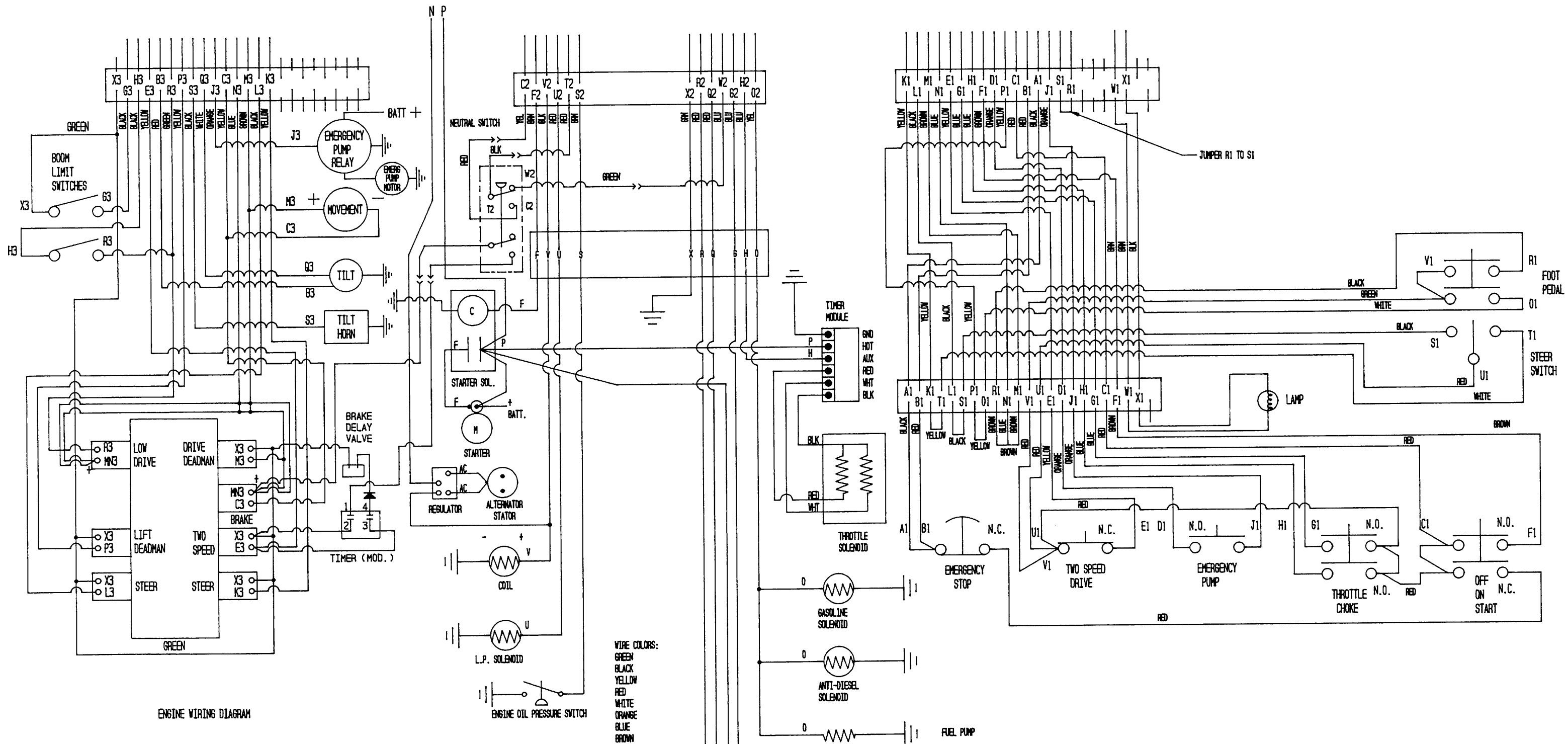

ENGINE WIRING DIAGRAM

CONN. LTR	WIRE NO.	COLOR
A	1	BLK
B	2	RED
C	3	RED/BLK
D	4	ORNG
E	5	YLM
F	6	BRN
G	7	BLUE
H	8	BLUE/BLK
J	9	ORNG/BLK
K	10	YLM/BLK
L	11	BLK/RED
M	12	BRN/BLK
N	13	BLUE/RED
O	14 (SPARE)	YLM/RED
P	15	ORNG/RED
Q	16	PLUG
R	17	PLUG
S	18	PLUG
T	19	PLUG
U	20	PLUG
V	21	PLUG
W	22	PLUG
X	23	BRN/RED
	24	BLK/BLU

CONN. LTR	WIRE NO.	COLOR
A	1	BLK
B	2	RED
C	3	RED/BLK
D	4	ORNG
E	5	YLM
F	6	BRN
G	7	BLUE
H	8	BLUE/BLK
J	9	ORNG/BLK
K	10	YLM/BLK
L	11	BLK/RED
M	12	BRN/BLK
N	13	BLUE/RED
O	14 (SPARE)	YLM/RED
P	15	ORNG/RED
Q	16	BLK
R	17	BLK
S	18	STEER SW
T	19	STEER SW
U	20	STEER SW
V	21	STEER SW
W	22	FOOT SW
X	23	FOOT SW
	24	BLK/BLU

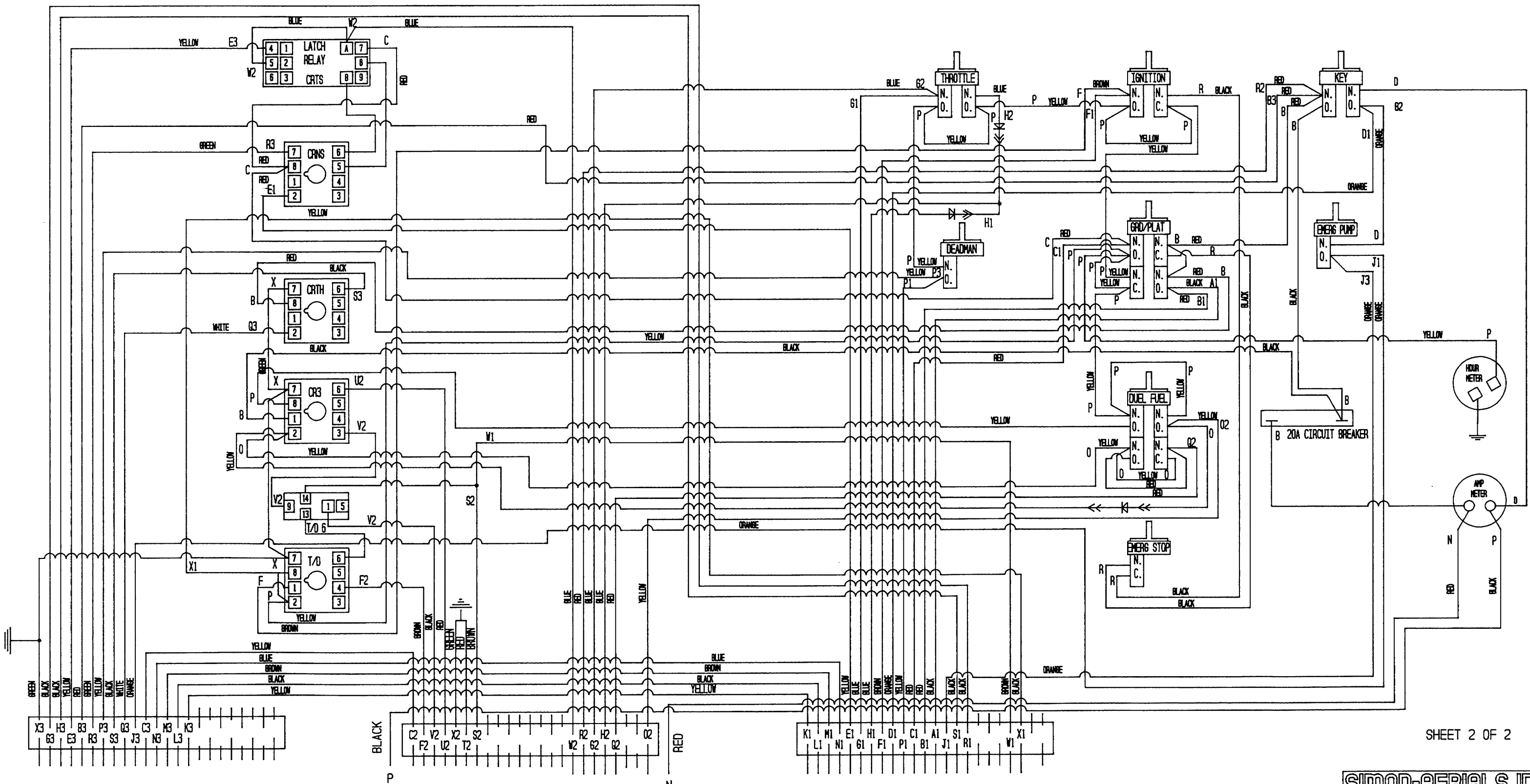

SHEET 2 OF 2

SIMON-AERIALS INC.
MILWAUKEE, WI. 53224

TITLE WIRING DIAGRAM DUAL FUEL
30 H.P. WIS. AT40C

REVISION DRWG. NO. SDS-216457-0

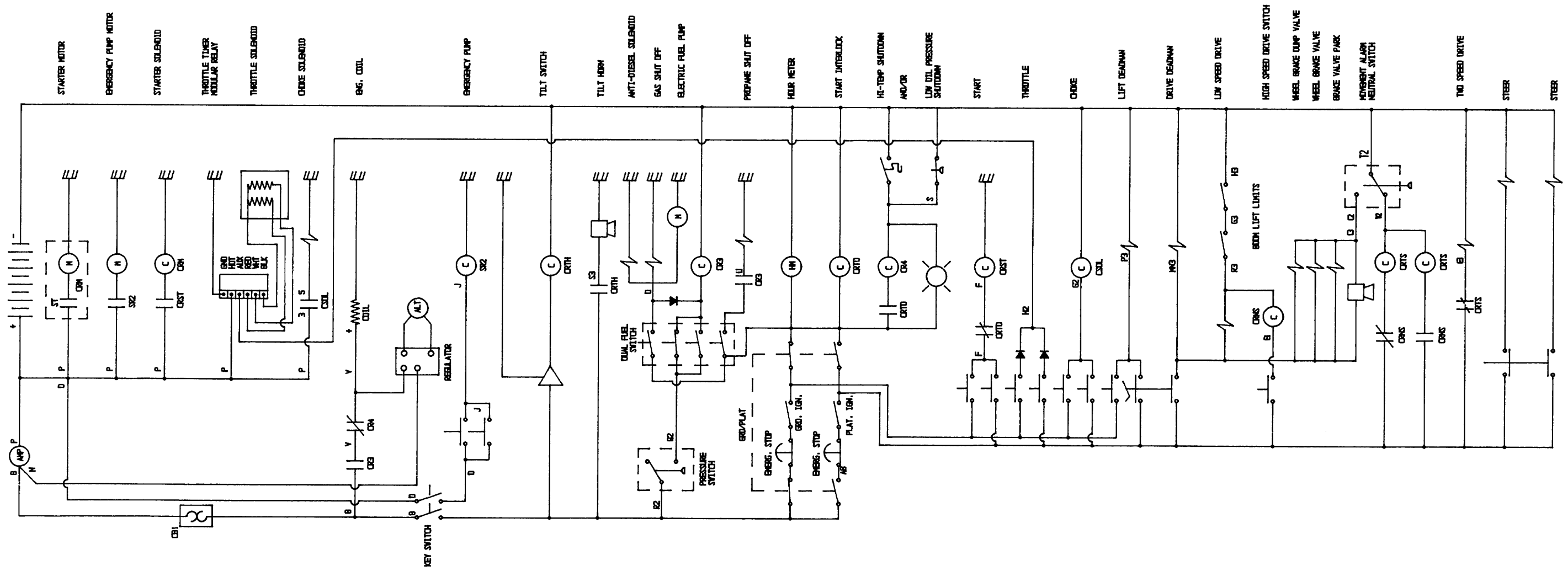

SIMON-AERIALS INC. <small>MILWAUKEE, WI. 53224</small>	
TITLE ELECTRICAL SCHEMATIC KUBOTA DUAL FUEL	
REVISION	DRWG. NO. SDS-219819-0

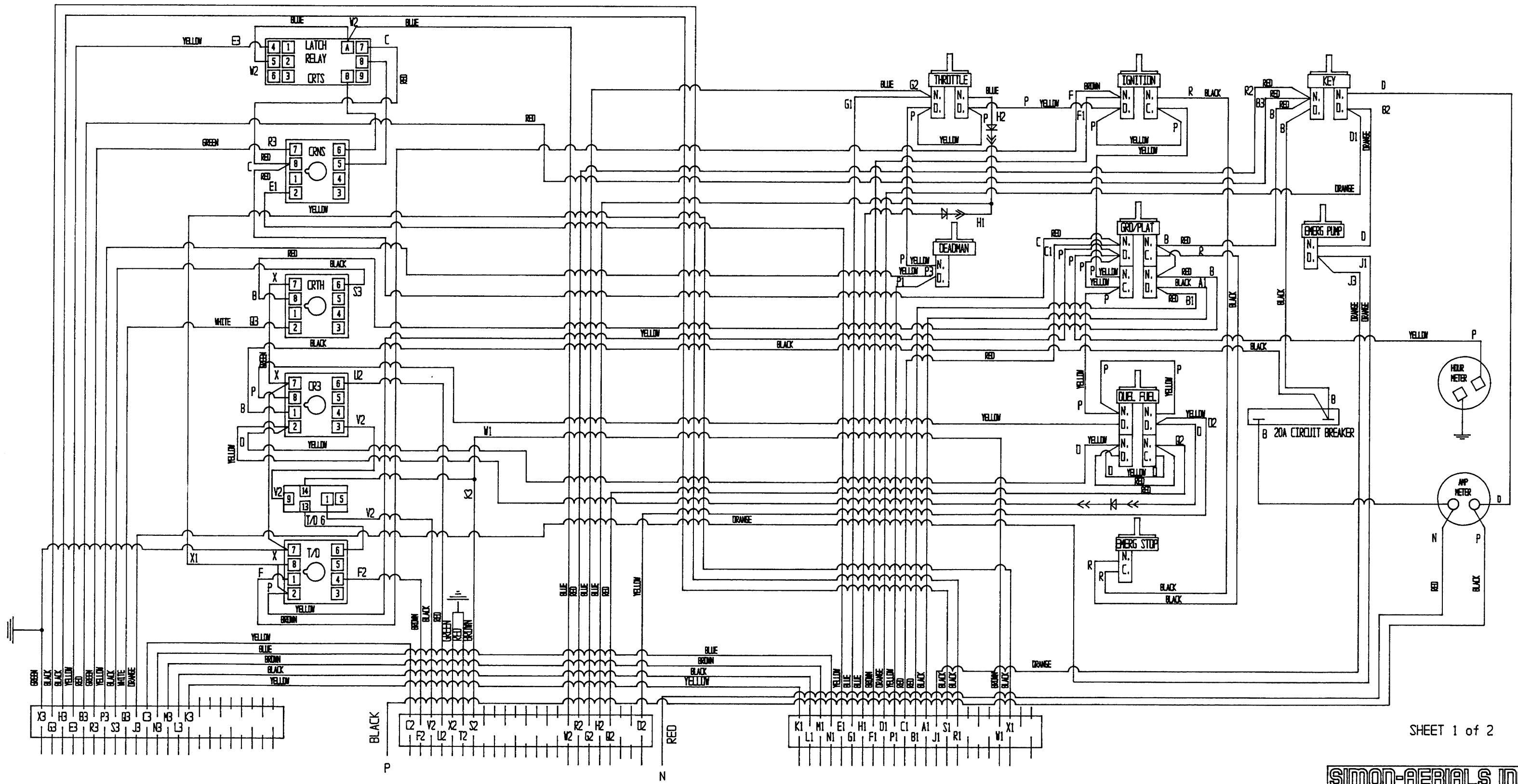

SIMON-AERIALS INC.
 MILWAUKEE, WI. 53224

TITLE
 ELECTRICAL SCHEMATIC AT40C
 DUAL FUEL KUBOTA 30 HP WISC

REVISION _____ DRWG. NO. SDS-219820-0

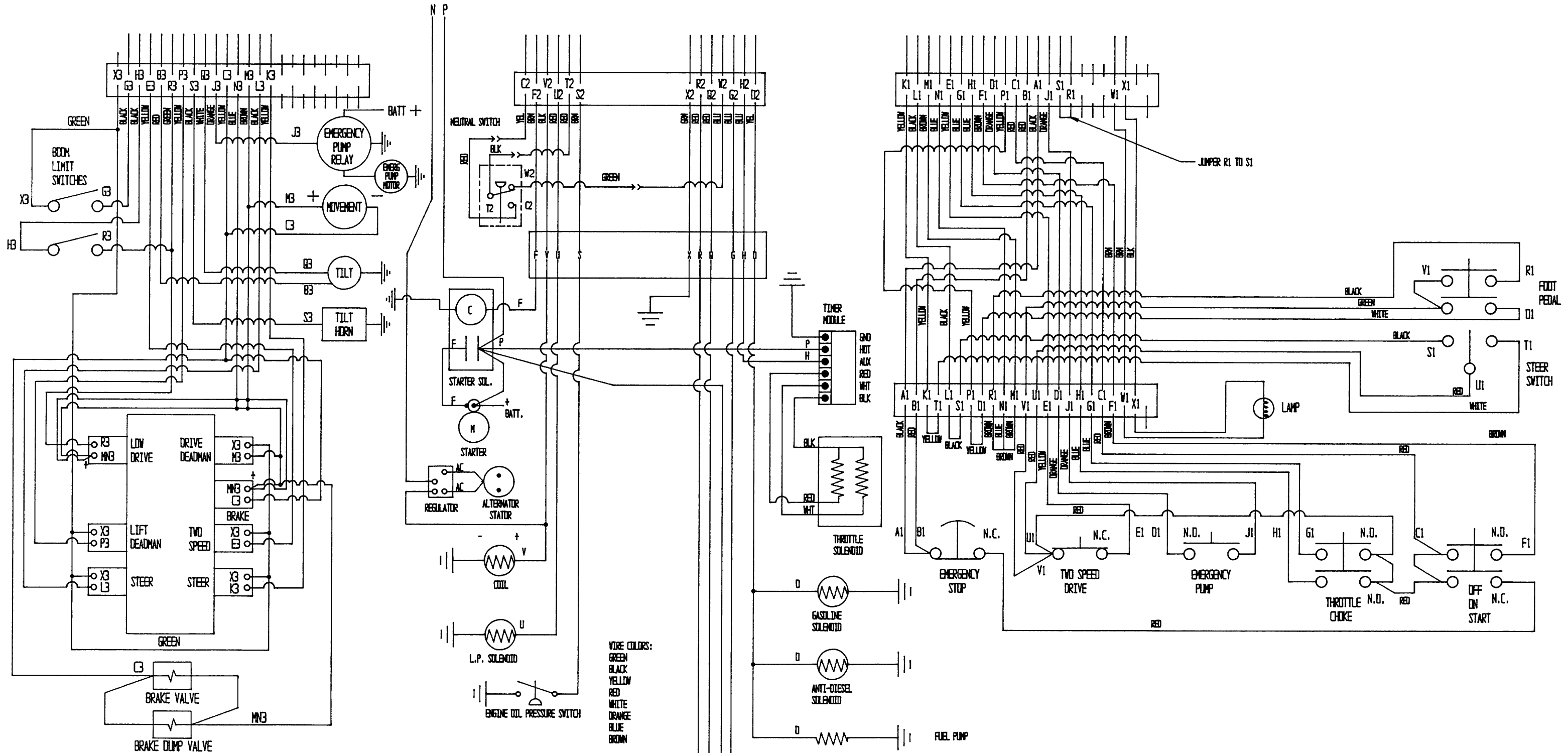

24 CONDUCTOR CONNECTION AT GRD BOX

CONN. LTR	WIRE NO.	COLOR
A	1	BLK
B	2	RED
C	7	RED/BLK
D	4	DRNG
E	5	YLV
F	6	BRN
G	3	BLUE
H	8	BLUE/BLK
J	9	DRNG/BLK
K	10	YLV/BLK
L	12	BLK/RED
M	11	BRN/BLK
N	13	BLUE/RED
P	PLUG	YLV/RED
Q	14 (SPARE)	DRNG/RED
R	18	---
S	19	---
T	PLUG	---
U	PLUG	---
V	PLUG	---
W	16	BRN/RED
X	17	BLK/BLU

24 CONDUCTOR CONNECTION AT PLATFORM

CONN. LTR	WIRE NO.	COLOR
A	1	BLK
B	2	RED
C	7	RED/BLK
D	4	DRNG
E	5	YLV
F	6	BRN
G	3	BLUE
H	8	BLUE/BLK
J	9	DRNG/BLK
K	10	YLV/BLK
L	12	BLK/RED
M	11	BRN/BLK
N	13	BLUE/RED
P	15	WHT
Q	14 (SPARE)	YLV/RED
R	18	DRNG/RED
S	19	BLK
T	FOOT SW	WHT
U	FOOT SW	RED
V	STEER SW	BRN/RED
W	STEER SW	---
X	FOOT SW	---

WIRE COLORS:
 GREEN
 BLACK
 YELLOW
 RED
 WHITE
 ORANGE
 BLUE
 BROWN

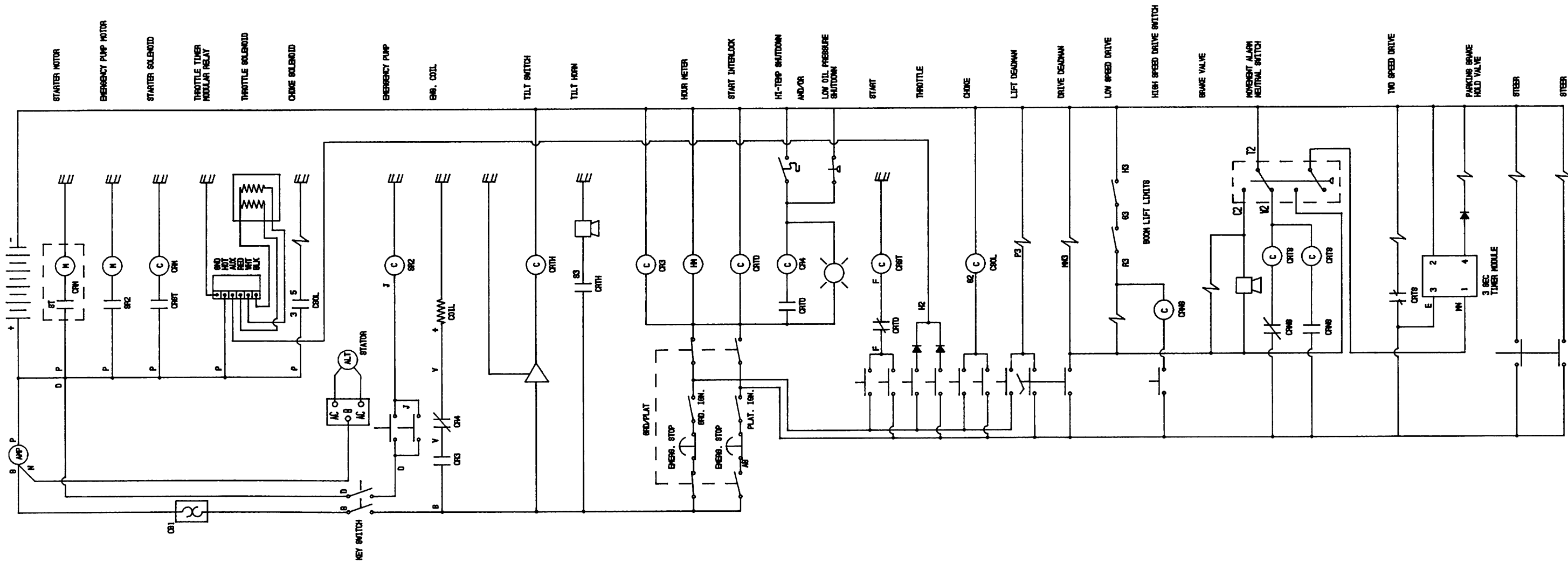

FOR 30 FT. MACHINES CONNECT
THE SINGLE BOOM LIMIT SWITCH
FROM X3 TO R3

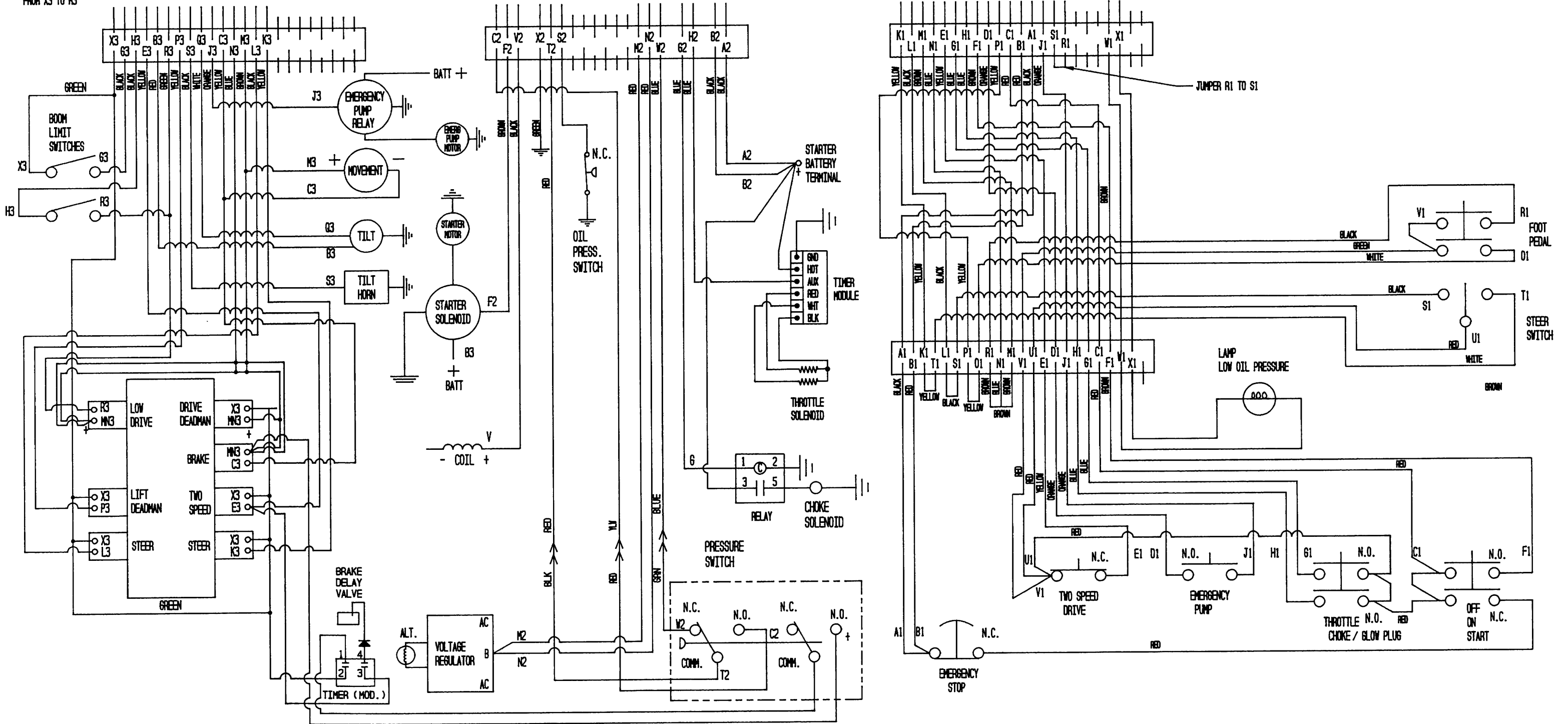

19 CONDUCTOR CONNECTION AT GRID BOX

CONN. LTR	WIRE NO.	COLOR
A	1	BLK
B	2	RED
C	7	RED/BLK
D	4	ORNG
E	5	YLW
F	6	BRN
G	3	BLUE
H	8	BLUE/BLK
J	9	ORNG/BLK
K	10	YLW/BLK
L	12	BLK/RED
M	11	BRN/BLK
N	13	BLUE/RED
O	PLUG	---
P	15	YLW/RED
Q	14 (SPARE)	ORNG/RED
R	18	---
S	19	---
T	PLUG	---
U	PLUG	---
V	PLUG	---
W	16	BRN/RED
X	17	BLK/BLU

19 CONDUCTOR CONNECTION AT PLATFORM

CONN. LTR	WIRE NO.	COLOR
A	1	BLK
B	2	RED
C	7	RED/BLK
D	4	ORNG
E	5	YLW
F	6	BRN
G	3	BLUE
H	8	BLUE/BLK
J	9	ORNG/BLK
K	10	YLW/BLK
L	12	BLK/RED
M	11	BRN/BLK
N	13	BLUE/RED
O	FOOT SW	WHT
P	15	YLW/RED
Q	14 (SPARE)	ORNG/RED
R	FOOT SW	BLK
S	STEER SW	BLK
T	STEER SW	WHT
U	STEER SW	RED
V	FOOT SW	GRN
W	16	BRN/RED
X	17	BLK/BLU

SIMON-AERIALS INC.
MILWAUKEE, WI. 53224

TITLE: WIRING DIAGRAM
P224 ONAN GASOLINE

REVISION: DRWG. NO. SDS-216351-0

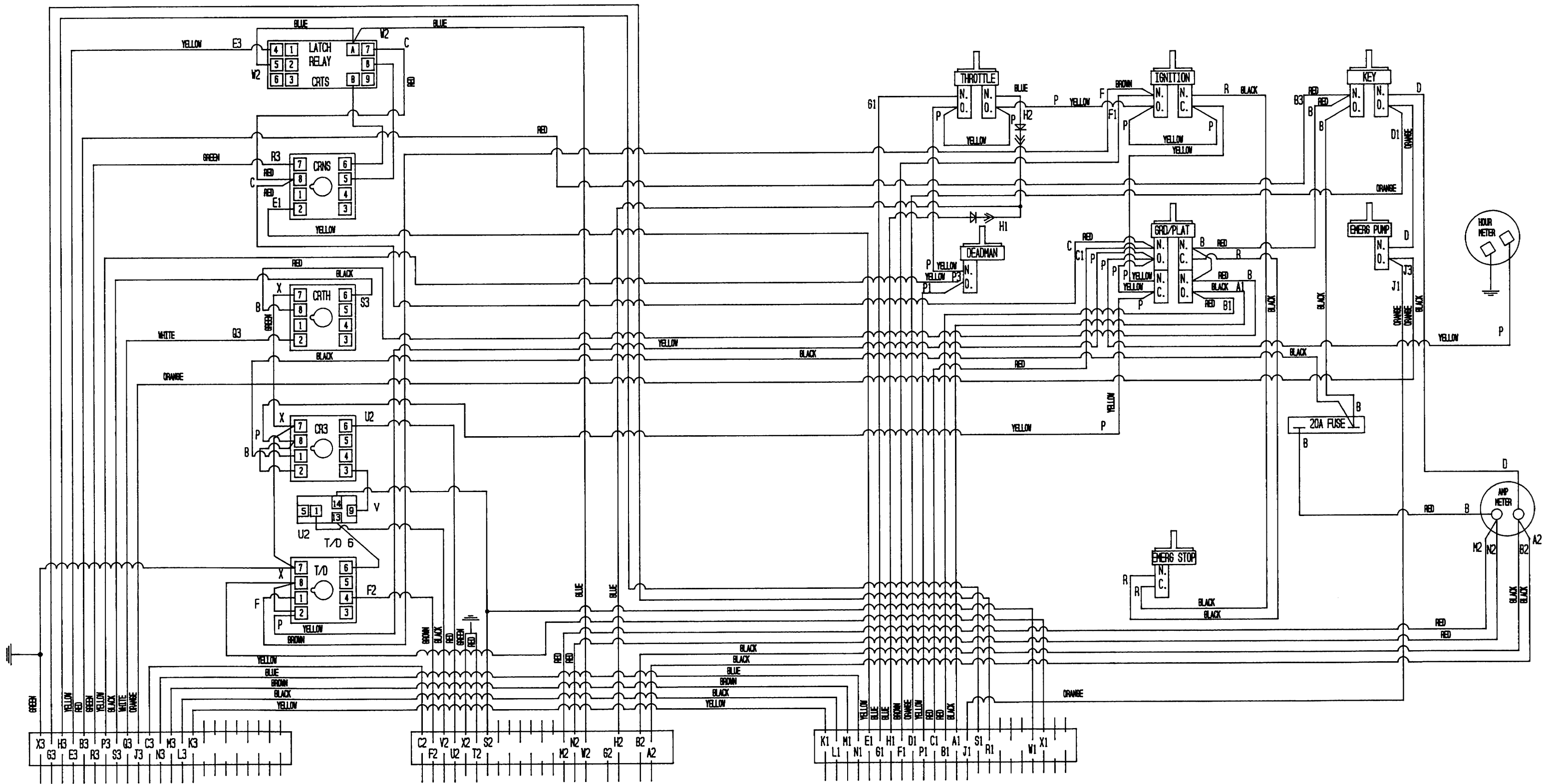

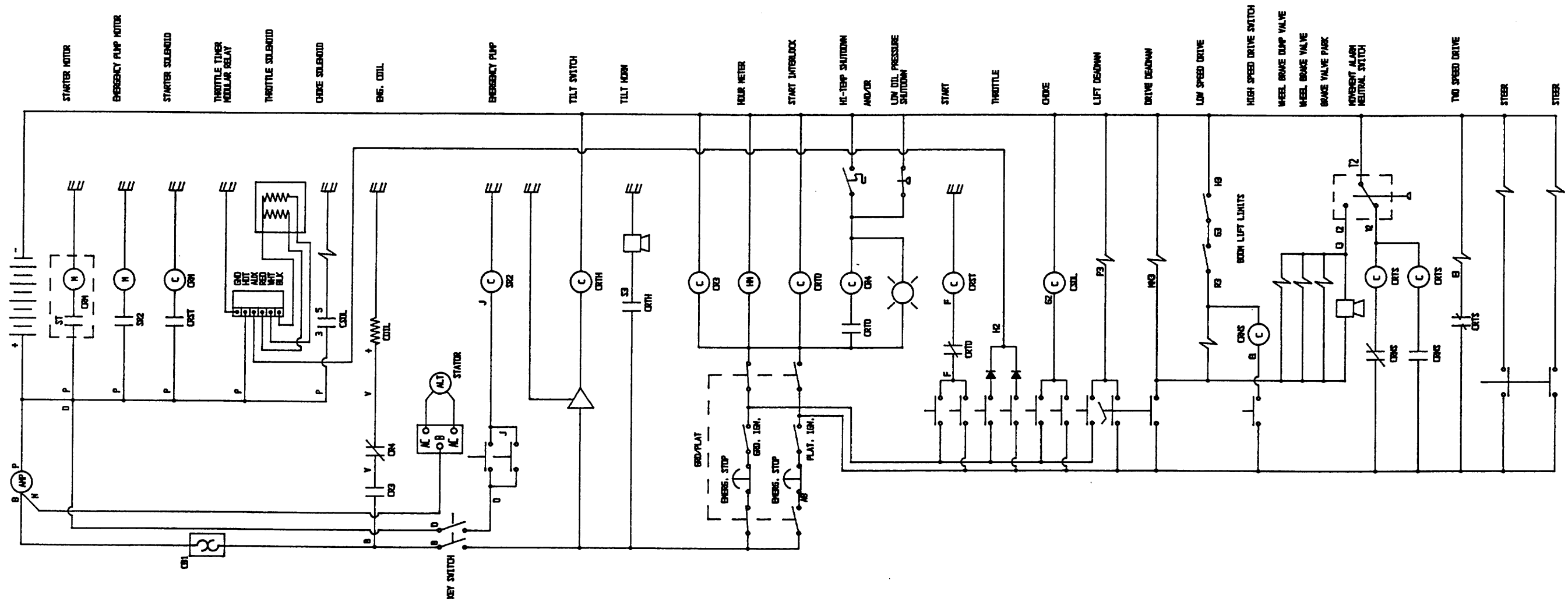

SIMON-AERIALS INC. MILWAUKEE, WI. 53224	
TITLE ELECTRICAL SCHEMATIC AT40C P224 DNAN GAS.	
REVISION	DRWG. NO. SDS-219821-0

FOR 30 FT. MACHINES CONNECT
THE SINGLE BOOM LIMIT SWITCH
FROM X3 TO R3

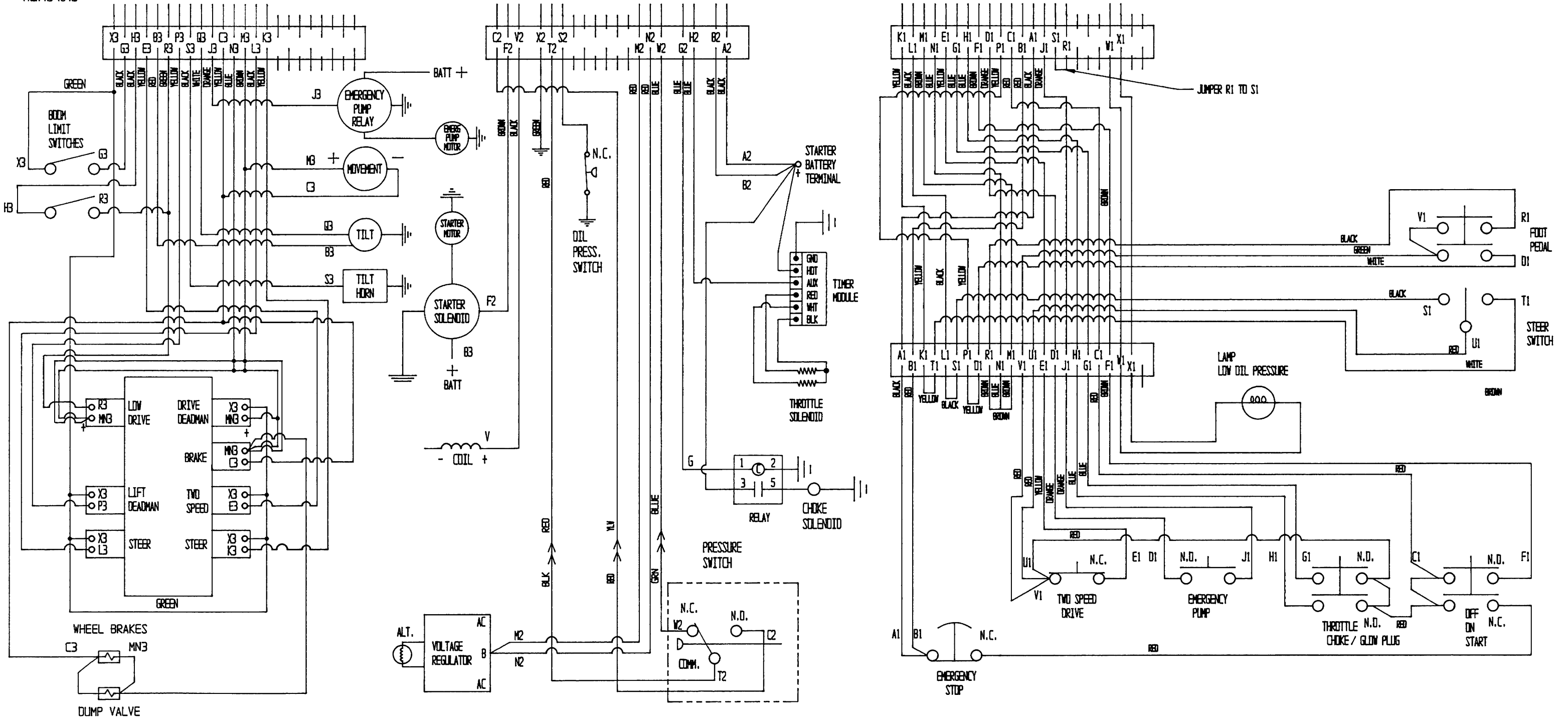

19 CONDUCTOR CONNECTION AT GND BOX		
CONN. LTR	WIRE NO.	COLOR
A	1	BLK
B	2	RED
C	7	RED/BLK
D	4	DRNG
E	5	YLV
F	6	BRN
G	3	BLU
H	8	BLU/BLK
J	9	DRNG/BLK
K	10	YLV/BLK
L	12	BLK/RED
M	11	BRN/BLK
N	13	BLU/RED
D	PLUG	
P	15	YLV/RED
B	14 (SPARE)	DRNG/RED
R	18	
S	19	
T	PLUG	
U	PLUG	
V	16	BRN/RED
W	17	BLK/BLU

19 CONDUCTOR CONNECTION AT PLATFORM		
CONN. LTR	WIRE NO.	COLOR
A	1	BLK
B	2	RED
C	7	RED/BLK
D	4	DRNG
E	5	YLV
F	6	BRN
G	3	BLU
H	8	BLU/BLK
J	9	DRNG/BLK
K	10	YLV/BLK
L	12	BLK/RED
M	11	BRN/BLK
N	13	BLU/RED
D	PLUG SW	
P	15	YLV/RED
B	14 (SPARE)	DRNG/RED
R	18	BLK
S	19	BLK
T	STEER SW	
U	STEER SW	
V	STEER SW	
W	16	GRN
X	17	BRN/RED

SIMON-AERIALS INC.
MILWAUKEE, WI. 53224

TITLE: ELECTRICAL SCHEMATIC
P224 DWAN GASOLINE

REVISION: _____ DRWG. NO.: SDS-219822-0

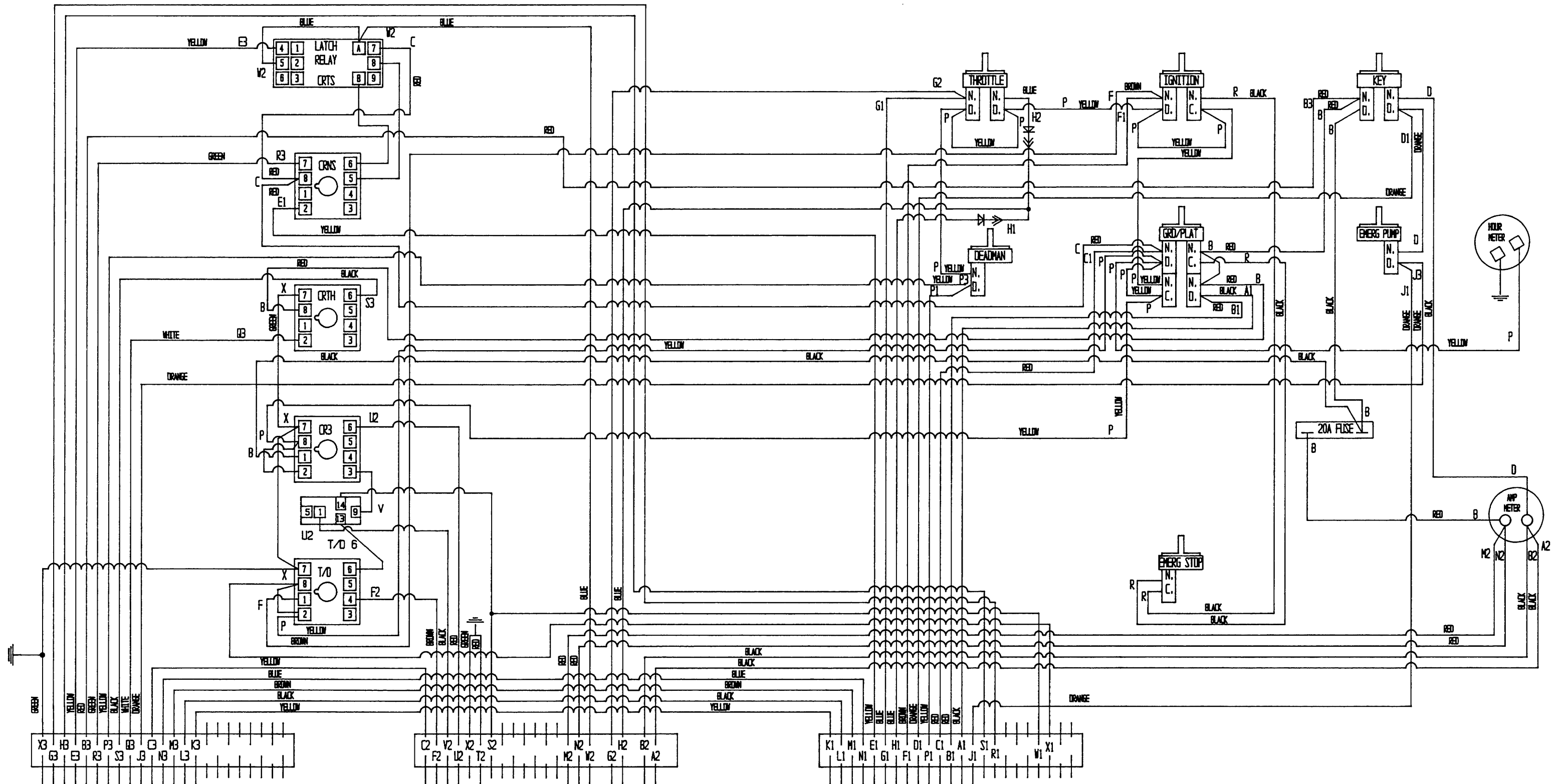

SIMON-AERIALS INC.
WILMINGTON, VT. 55224

TITLE ELECTRICAL SCHEMATIC
 P224 C/NAN GASOLINE AT40C

REVISION ORG. NO. SDS-219822-0

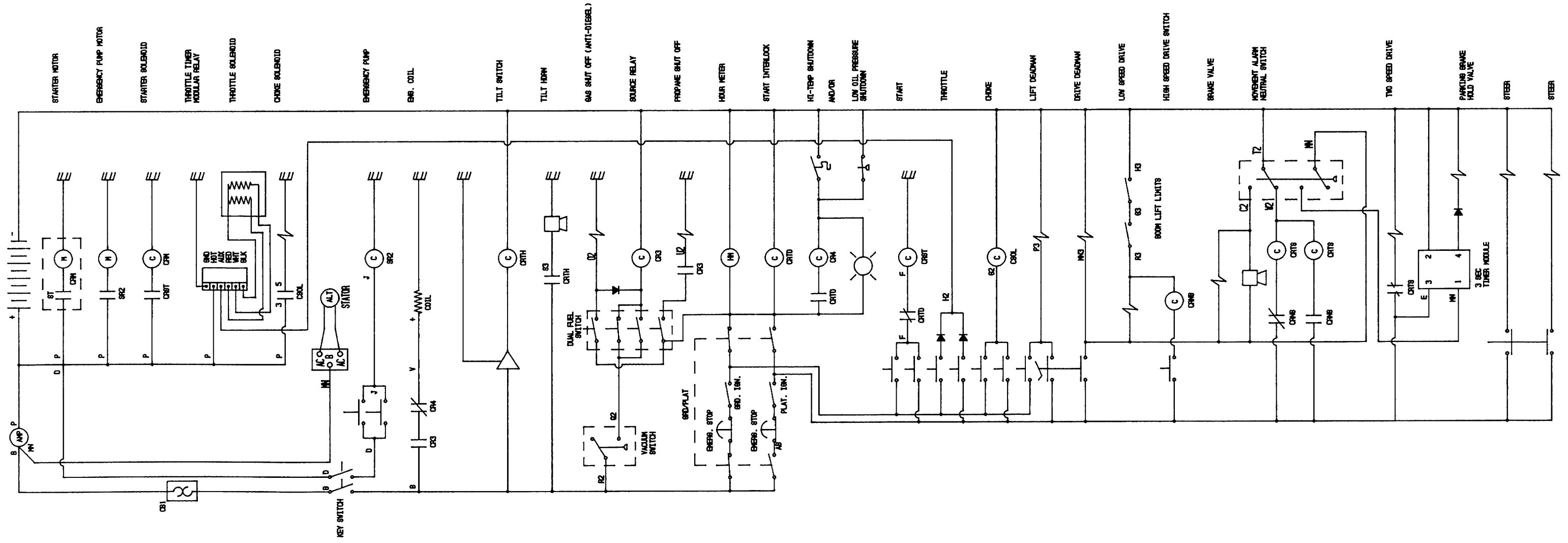

SIMON-AERIALS INC. MILWAUKEE, WI. 53224	
TITLE ELECTRICAL SCHEMATIC DUAL FUEL/P224 ONAN/AT40C	
REVISION	DRWG. NO. SDS-216353-0

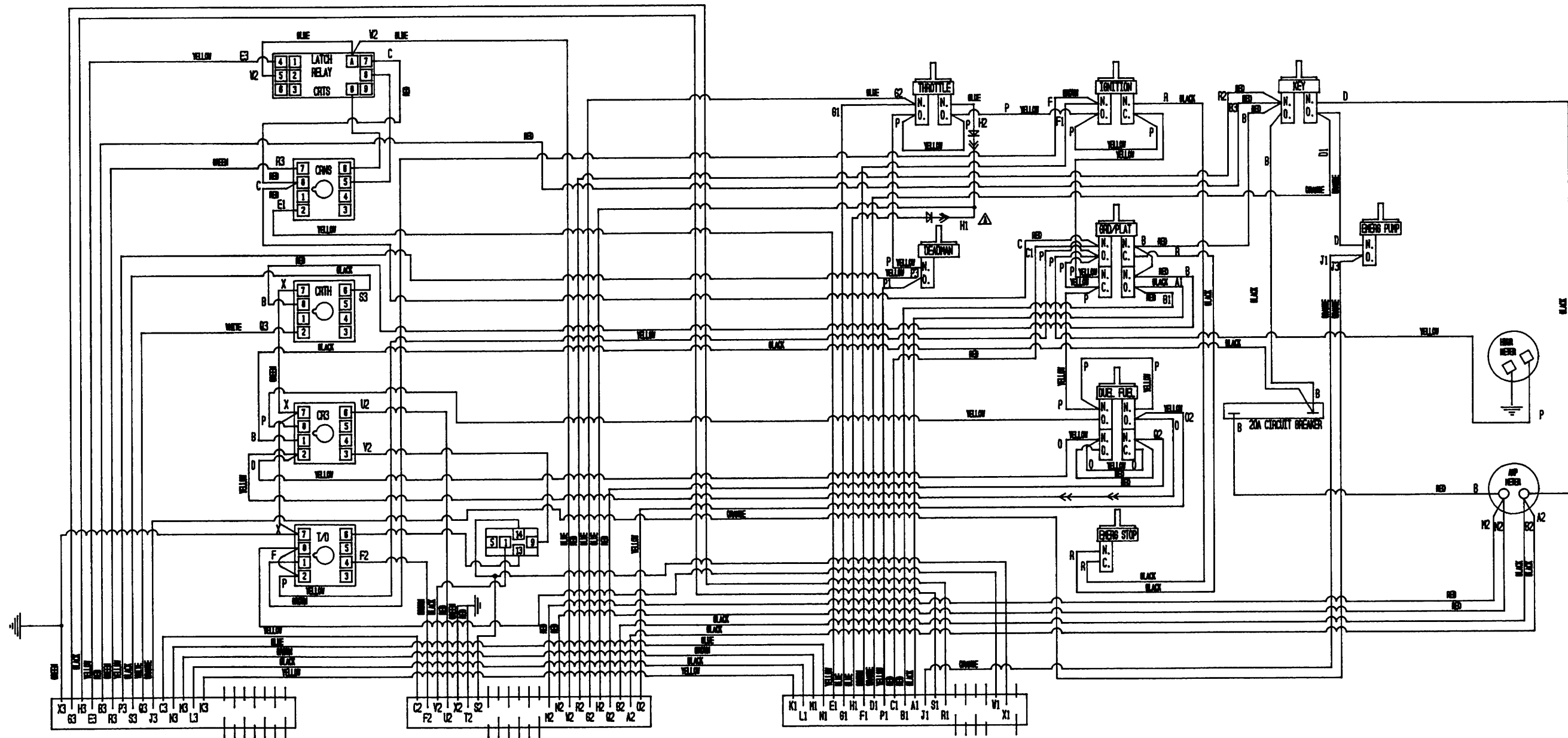

WIRE COLORS:
 GREEN
 BLACK
 YELLOW
 RED
 WHITE
 ORANGE
 BLUE
 BROWN

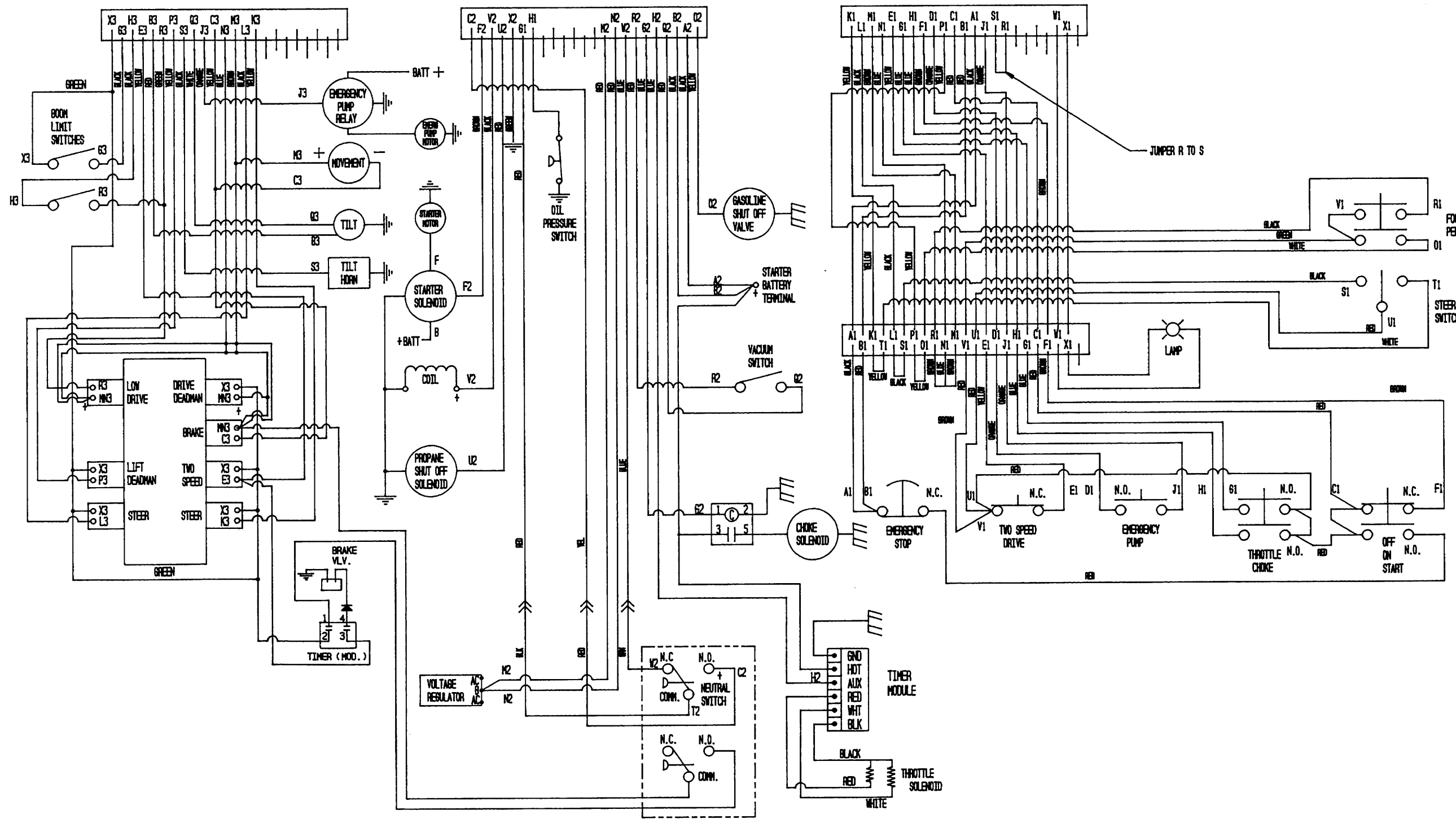

19 CONDUCTOR CONNECTIONS AT GROUND BOX

CONN. LETTER	WIRE NO.	COLOR
A	1	BLACK
B	2	RED
C	7	RED/BLACK
D	4	ORANGE
E	5	YELLOW
F	6	BROWN
G	3	BLUE
H	8	BLUE/BLACK
J	9	ORANGE/BLACK
K	10	YELLOW/BLACK
L	12	BLK/RED
N	11	GRN/BLK
O	13	BLU/RED
P	15	YELLOW/RED
Q	14 (SPARE)	ORANGE/RED
R	PLUG	---
S	PLUG	---
T	PLUG	---
U	PLUG	---
V	PLUG	---
W	16	BROWN/RED
X	17	BLACK/BLU

19 CONDUCTOR CONNECTIONS AT PLATFORM

CONN. LETTER	WIRE NO.	COLOR
A	1	BLACK
B	2	RED
C	7	RED/BLACK
D	4	ORANGE
E	5	YELLOW
F	6	BROWN
G	3	BLUE
H	8	BLUE/BLACK
J	9	ORANGE/BLACK
K	10	YELLOW/BLACK
L	12	BLK/RED
N	11	GRN/BLK
O	13	BLU/RED
P	15	WHITE
Q	14 (SPARE)	YELLOW/RED
R	14 (SPARE)	ORANGE/RED
S	FOOT SWITCH	BLACK
T	FOOT SWITCH	BLACK
U	STEER SWITCH	WHITE
V	STEER SWITCH	RED
W	FOOT SWITCH	GREEN
X	16 (SPARE)	BROWN/RED
	17 (SPARE)	BLK/BLU

SHEET 1 OF 2

SHEET 2 OF 2

SIMON-AERIALS INC.
 KELOWA, VT. 53224

TITLE: WIRING DIAGRAM
 DUEL FUEL AT40C T265 ONAN W/O BRAKES

REVISION: _____ DRWG. NO. SDS-216348-0

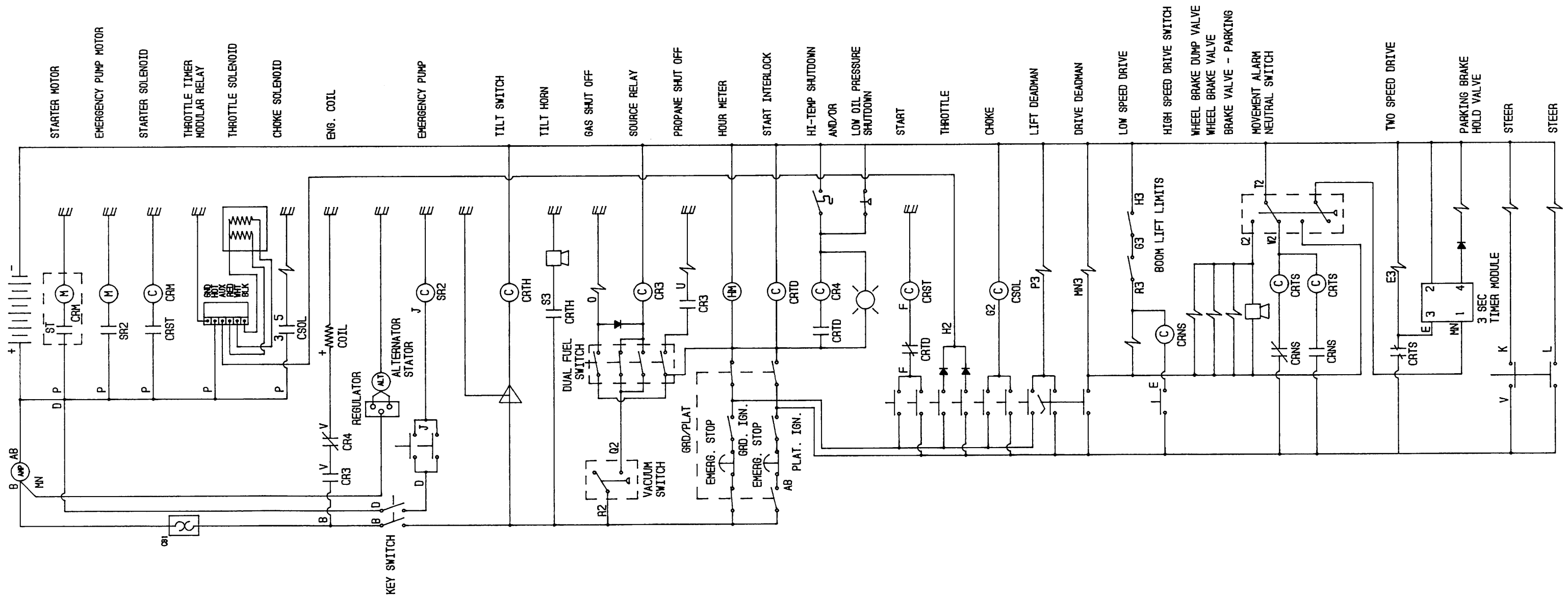

- STARTER MOTOR
- EMERGENCY PUMP MOTOR
- STARTER SOLENOID
- THROTTLE TIMER MODULAR RELAY
- THROTTLE SOLENOID
- CHOKE SOLENOID
- ENG. COIL
- EMERGENCY PUMP
- TILT SWITCH
- TILT HORN
- GAS SHUT OFF
- SOURCE RELAY
- PROPANE SHUT OFF
- HOUR METER
- START INTERLOCK
- HI-TEMP SHUTDOWN AND/OR
- LOW OIL PRESSURE SHUTDOWN
- START
- THROTTLE
- CHOKE
- LIFT DEADMAN
- DRIVE DEADMAN
- LOW SPEED DRIVE
- HIGH SPEED DRIVE SWITCH
- WHEEL BRAKE DUMP VALVE
- WHEEL BRAKE VALVE
- BRAKE VALVE - PARKING
- MOVEMENT ALARM NEUTRAL SWITCH
- TWO SPEED DRIVE
- PARKING BRAKE HOLD VALVE
- STEER
- STEER

SIMON AERIALS INC.
MILWAUKEE, WI. 53224

TITLE ELECTRICAL SCHEMATIC
 AT40C / DUAL FUEL (ONAN)

REVISION C / 7-10-90 DRAWG. NO. SDS-214178-0

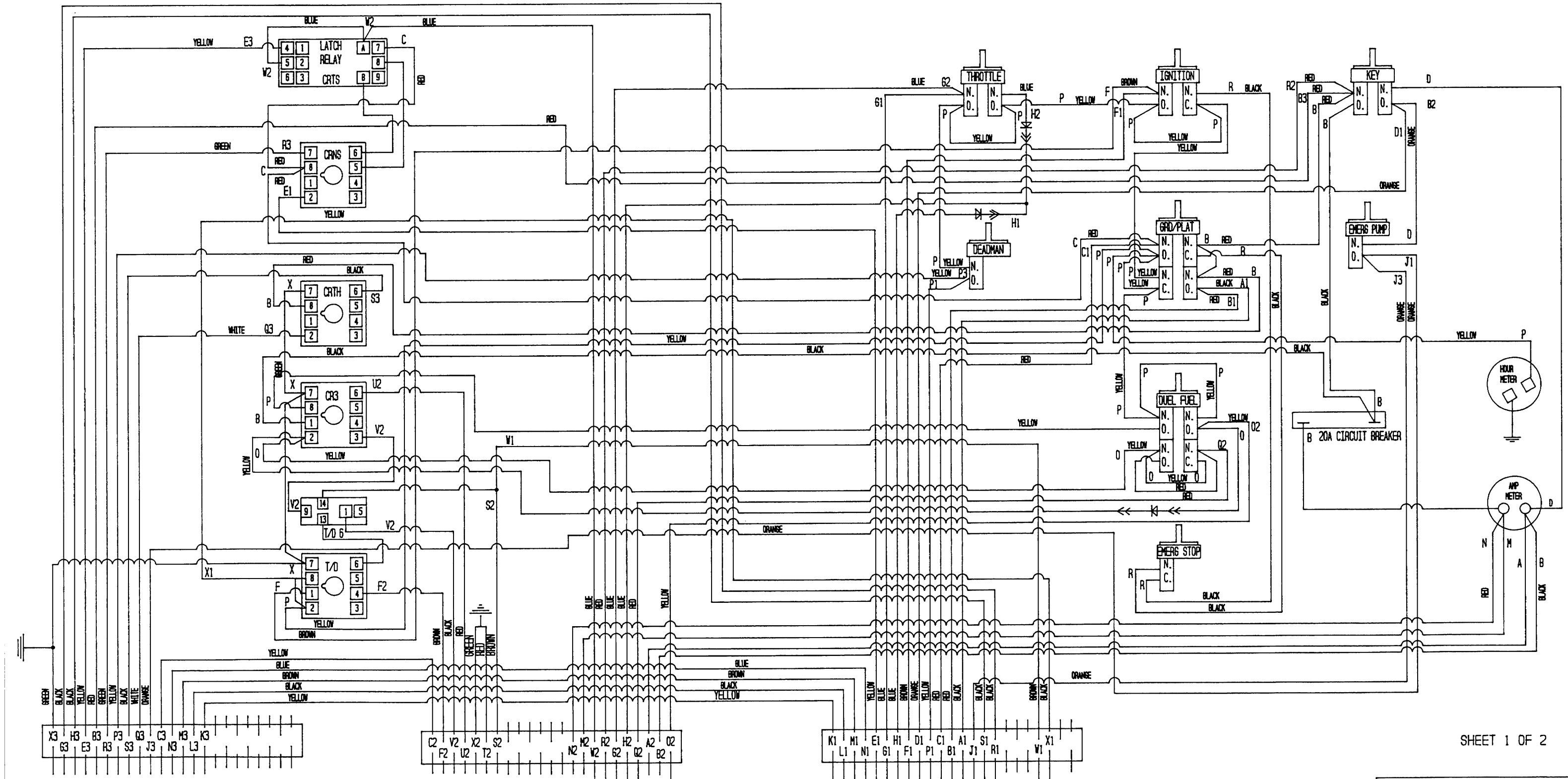

SHEET 1 OF 2

SIMON-AERIALS INC. <small>KELVUWAKE, V.I. 53224</small>	
TITLE WIRING DIAGRAM DUAL FUEL ONAN W/BRAKES AT40C	
REVISION	DRAWG. NO. SDS-216348-0

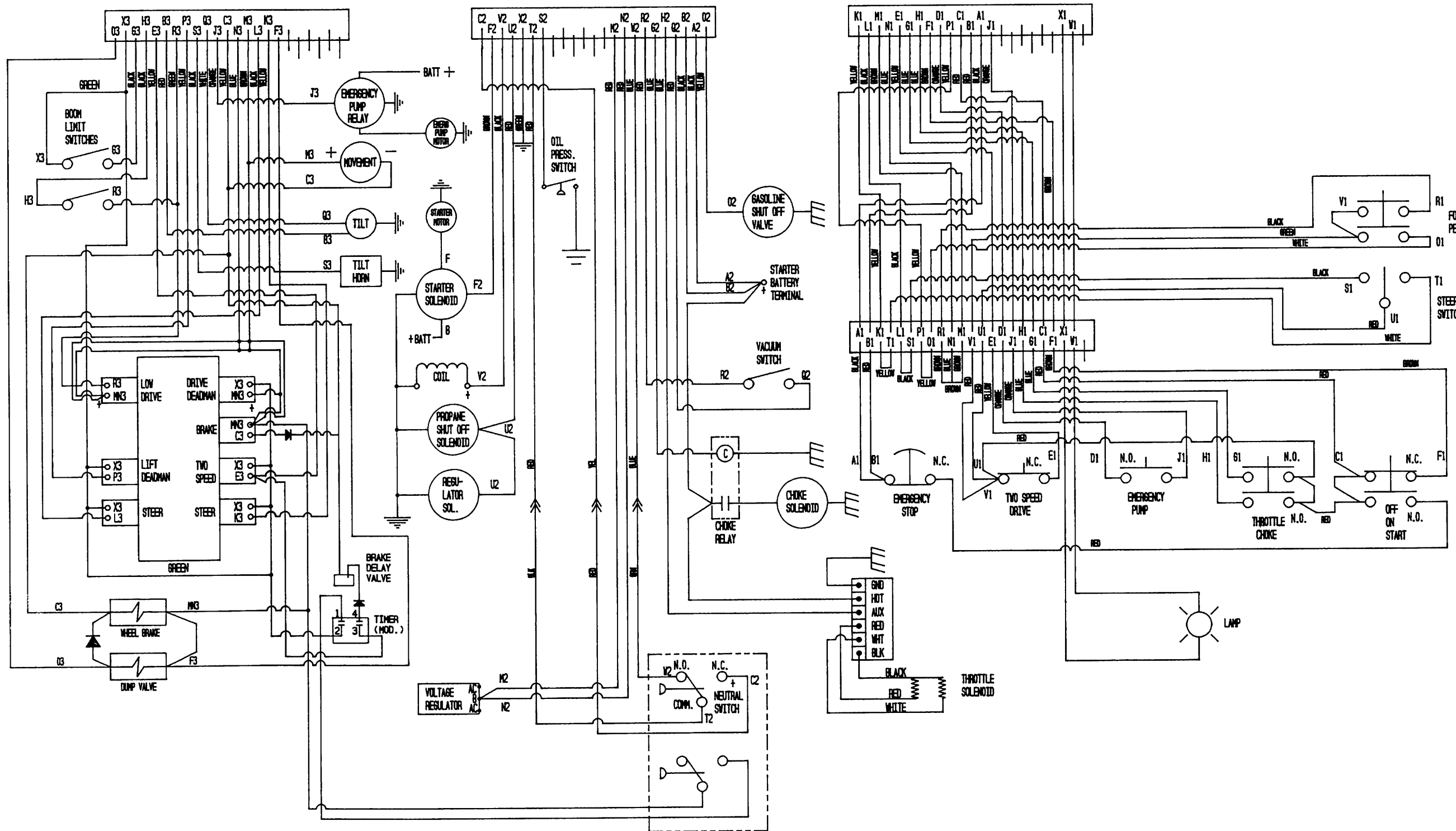

19 CONDUCTOR CONNECTIONS AT GROUND BOX

CONN. LETTER	WIRE NO.	COLOR
A	1	BLACK
B	2	RED
C	7	RED/BLACK
D	4	ORANGE
E	5	YELLOW
F	6	BROWN
G	3	BLUE
H	8	BLUE/BLACK
J	9	ORANGE/BLACK
K	10	YELLOW/BLACK
L	12	BLK/RED
N	11	BRN/BLK
O	13	BLUE/RED
P	15	YELLOW/RED
Q	14 (SPARE)	ORANGE/RED
R	PLUG	---
S	PLUG	---
T	PLUG	---
U	PLUG	---
V	PLUG	---
W	16	BRN/RED
X	17	BLK/BLU

19 CONDUCTOR CONNECTIONS AT PLATFORM

CONN. LETTER	WIRE NO.	COLOR
A	1	BLACK
B	2	RED
C	7	RED/BLACK
D	4	ORANGE
E	5	YELLOW
F	6	BROWN
G	3	BLUE
H	8	BLUE/BLACK
J	9	ORANGE/BLACK
K	10	YELLOW/BLACK
L	12	BLK/RED
N	11	BRN/BLK
O	13	BLUE/RED
P	15	YELLOW/RED
Q	14 (SPARE)	ORANGE/RED
R	FOOT SWITCH	WHITE
S	FOOT SWITCH	BLACK
T	STEER SWITCH	WHITE
U	STEER SWITCH	RED
V	FOOT SWITCH	GREEN
W	16 (SPARE)	BRN/RED
X	17 (SPARE)	BLK/BLU

SHEET 1 OF 2

SHEET 2 OF 2

SIMON-AERIALS INC.
 WILMINGTON, VT. 55224

TITLE: WIRING DIAGRAM AT40C AND S.A.I. EAGLE
 W/ BRAKES P224 ONAN

REVISION: _____ DRAW. NO.: SDS-216354-0

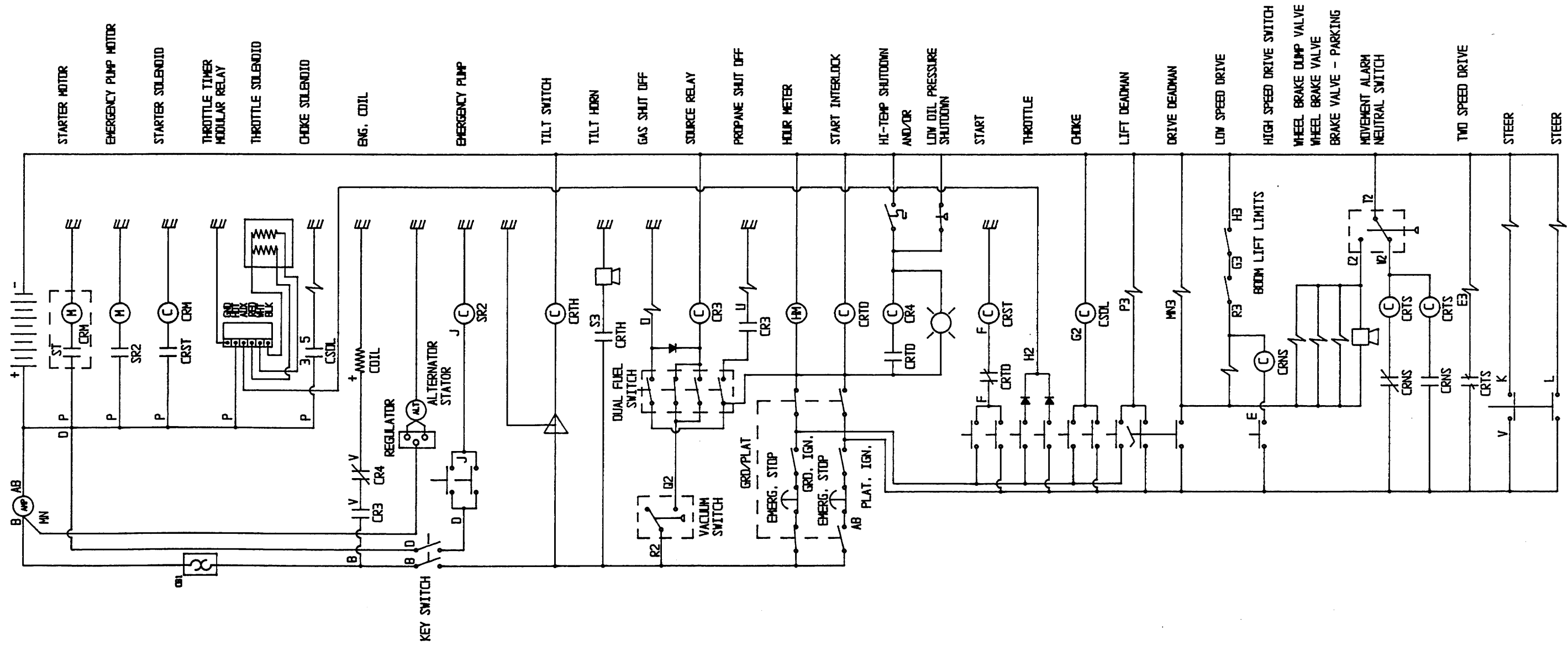

- STARTER MOTOR
- EMERGENCY PUMP MOTOR
- STARTER SOLENOID
- THROTTLE TIMER MODULAR RELAY
- THROTTLE SOLENOID
- CHOKE SOLENOID
- ENG. COIL
- EMERGENCY PUMP
- TILT SWITCH
- TILT HORN
- GAS SHUT OFF
- SOURCE RELAY
- PROPANE SHUT OFF
- HOUR METER
- START INTERLOCK
- HI-TEMP SHUTDOWN AND/OR
- LOW OIL PRESSURE SHUTDOWN
- START
- THROTTLE
- CHOKE
- LIFT DEADMAN
- DRIVE DEADMAN
- LOW SPEED DRIVE
- HIGH SPEED DRIVE SWITCH
- WHEEL BRAKE DUMP VALVE
- WHEEL BRAKE VALVE
- BRAKE VALVE - PARKING
- MOVEMENT ALARM NEUTRAL SWITCH
- TWO SPEED DRIVE
- STEER
- STEER

SIMON AERIALS INC.
 MILWAUKEE, WI. 53224

TITLE: ELECTRICAL SCHEMATIC
 AT40C / DUAL FUEL (GNAN)

REVISION: _____ DRWG. NO. SDS-219823-0

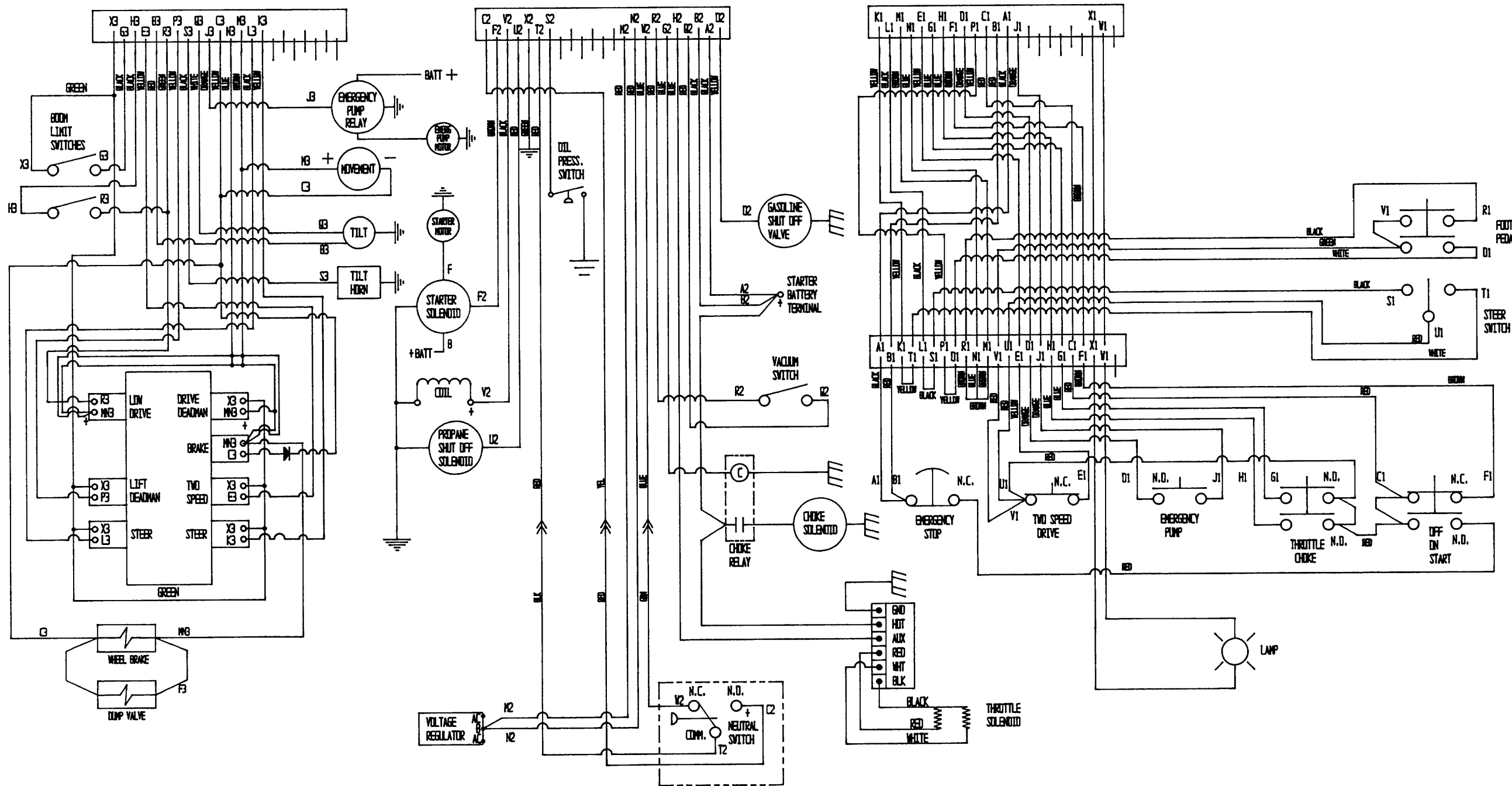

19 CONDUCTOR CONNECTIONS AT GROUND BOX

CONN. LETTER	WIRE NO.	COLOR
A	1	BLACK
B	2	RED
C	7	RED/BLACK
D	4	ORANGE
E	5	YELLOW
F	6	BROWN
G	3	BLUE
H	8	BLUE/BLACK
J	9	ORANGE/BLACK
K	10	YELLOW/BLACK
L	12	BLK/RED
N	11	GRN/BLK
O	13	BLU/RED
P	PLUG	---
R	15	YELLOW/RED
S	14 (SPARE)	ORANGE/RED
T	PLUG	---
U	PLUG	---
V	PLUG	---
W	16	BROWN/RED
X	17	BLK/YLU

19 CONDUCTOR CONNECTIONS AT PLATFORM

CONN. LETTER	WIRE NO.	COLOR
A	1	BLACK
B	2	RED
C	7	RED/BLACK
D	4	ORANGE
E	5	YELLOW
F	6	BROWN
G	3	BLUE
H	8	BLUE/BLACK
J	9	ORANGE/BLACK
K	10	YELLOW/BLACK
L	12	BLK/RED
N	11	GRN/BLK
O	13	BLU/RED
P	PLUG SWITCH	WHITE
R	15	YELLOW/RED
S	14 (SPARE)	ORANGE/RED
T	PLUG SWITCH	BLACK
U	PLUG SWITCH	WHITE
V	PLUG SWITCH	RED
W	16 (SPARE)	BROWN/RED
X	17 (SPARE)	BLK/YLU

SHEET 1 OF 2

SHEET 1 OF 2

SIMON-AERIALS INC.
 WILMANSBURG, VT. 55224

TITLE: ELECTRICAL SCHEMATIC AT40C & SAI EAGLE
 W/ BRAKES P224 ONAN

REVISION: _____ DRWG. NO.: SDS-219824-0

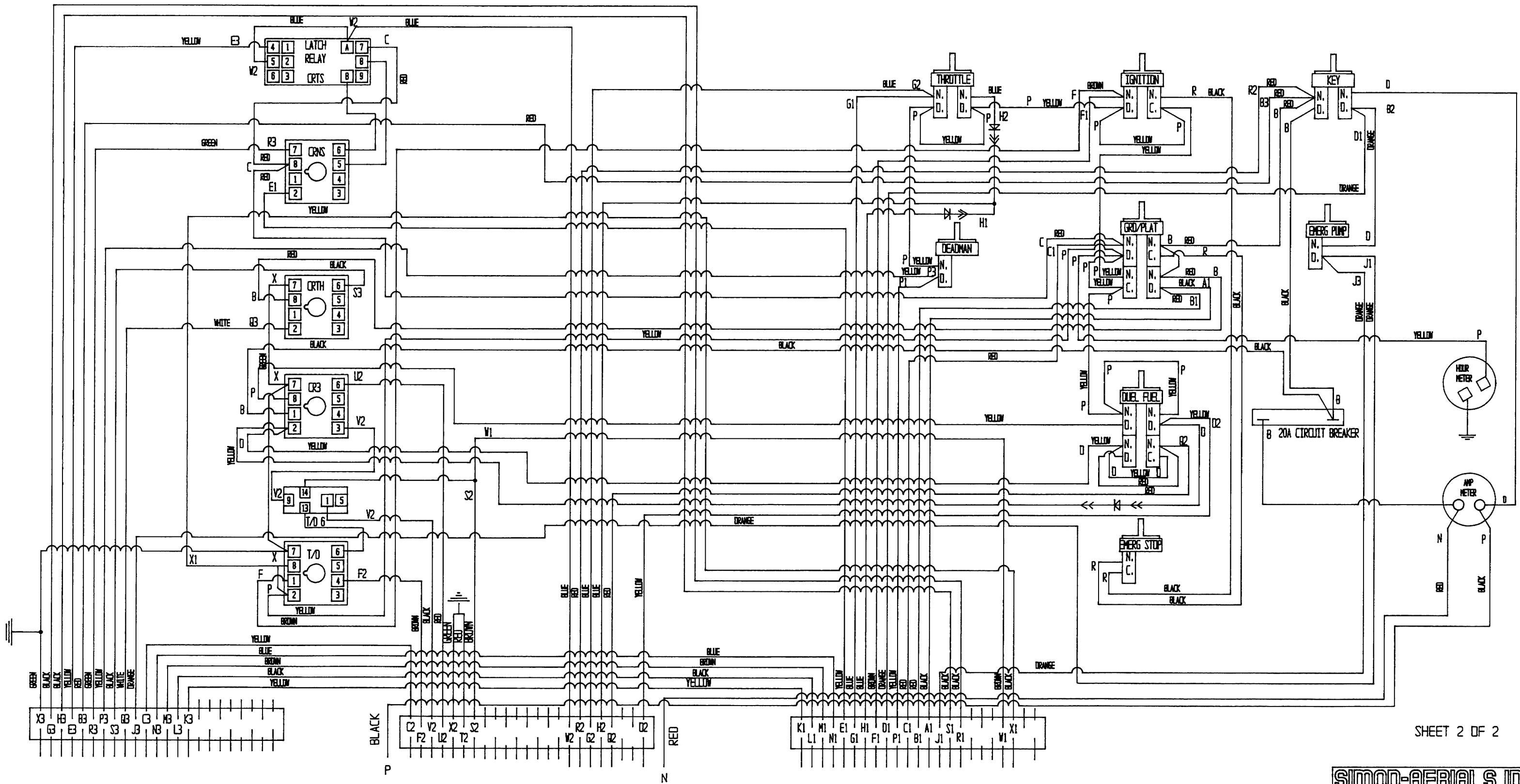

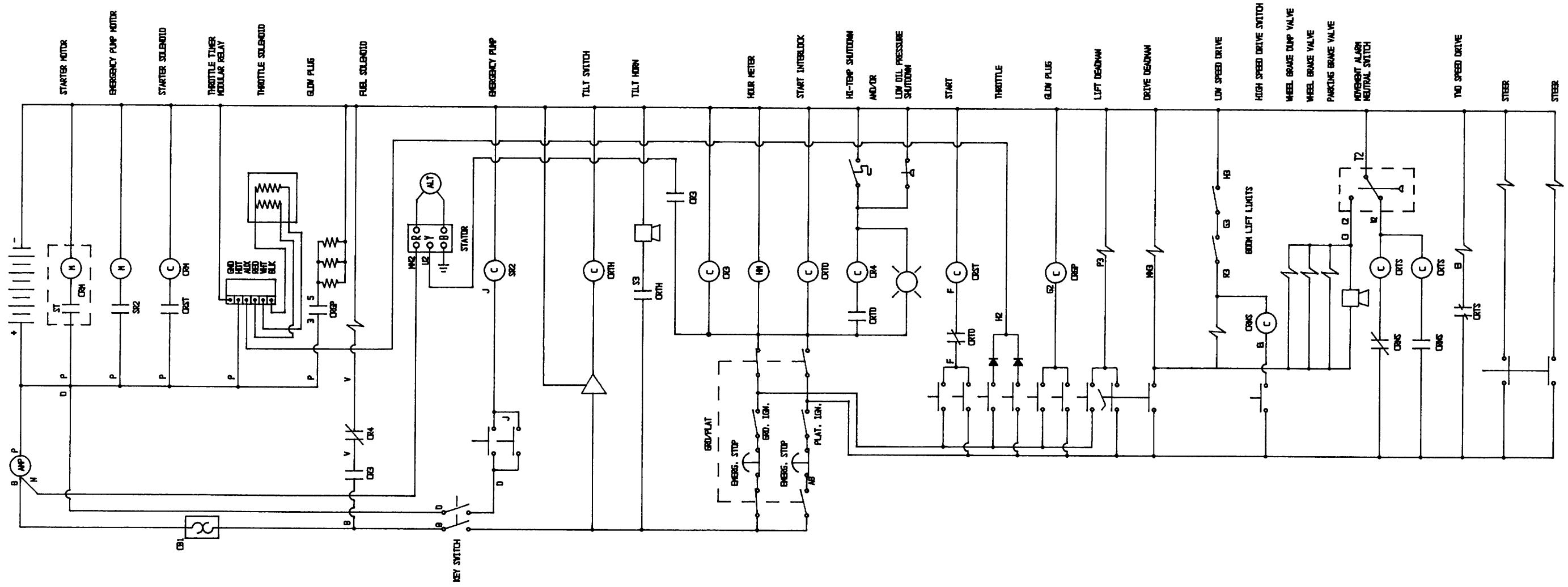

SIMON-AERIALS INC. MILWAUKEE, WI. 53224	
TITLE ELECTRICAL SCHEMATIC AT30C/AT40C-PERKINS 103.10	
REVISION 8 04-24-91	DRWG. NO. SDS-217516-0

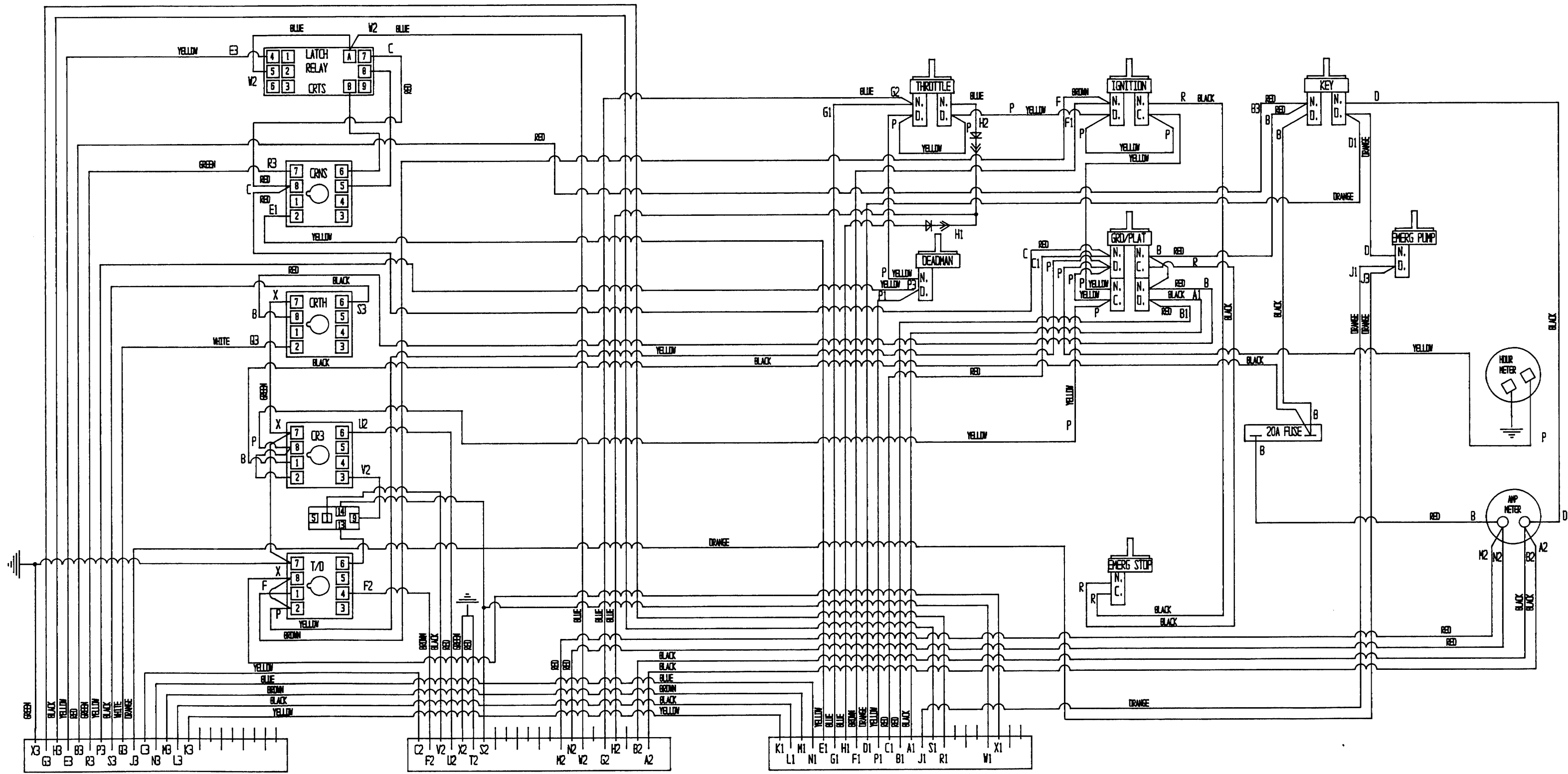

WIRE COLORS:
 GREEN
 BLACK
 YELLOW
 RED
 WHITE
 ORANGE
 BLUE
 BROWN

SIMON-AERIALS INC.
 MILWAUKEE, WI. 53224

TITLE: WIRING DIAGRAM
 AT30C/AT40C-PERKINS 103.10

REVISION: A 1-4-91 DRWG. NO.: SDS-217503-0

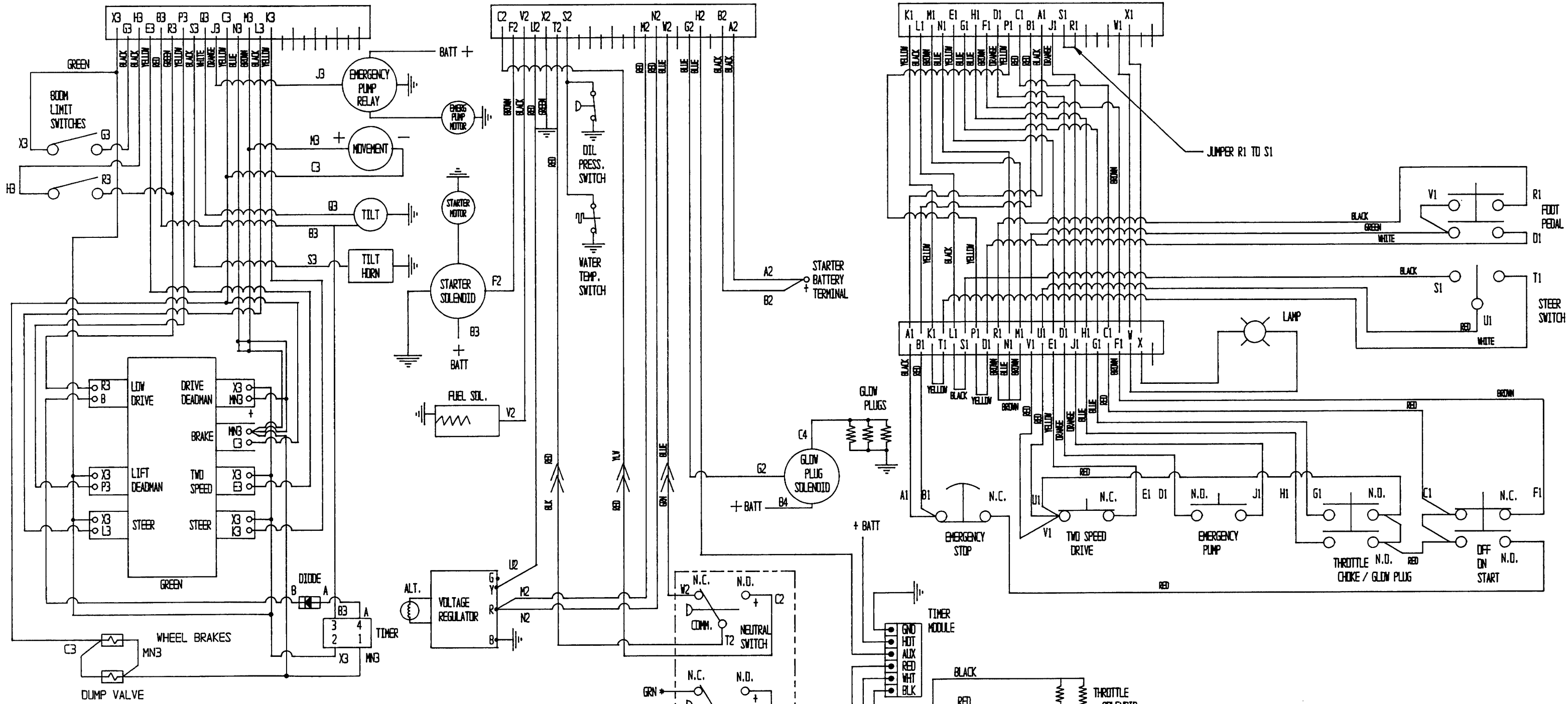

19 CONDUCTOR CONNECTIONS AT GROUND BOX

CONN. LETTER	WIRE NO.	COLOR
A	1	BLACK
B	2	RED
C	3	RED/BLACK
D	4	ORANGE
E	5	YELLOW
F	6	BROWN
G	7	BLUE
H	8	BLUE/BLACK
J	9	ORANGE/BLACK
K	10	YELLOW/BLACK
L	11	BLACK/RED
M	12	BROWN/BLACK
N	13	BROWN/RED
O	14	YELLOW/RED
P	15	ORANGE/RED
Q	16	SPARE
R	17	PLUG
S	18	PLUG
T	19	PLUG
U	20	PLUG
V	21	PLUG
W	22	PLUG
X	23	PLUG

19 CONDUCTOR CONNECTIONS AT PLATFORM

CONN. LETTER	WIRE NO.	COLOR
A	1	BLACK
B	2	RED
C	3	RED/BLACK
D	4	ORANGE
E	5	YELLOW
F	6	BROWN
G	7	BLUE
H	8	BLUE/BLACK
J	9	ORANGE/BLACK
K	10	YELLOW/BLACK
L	11	BLACK/RED
M	12	BROWN/BLACK
N	13	BROWN/RED
O	14	YELLOW/RED
P	15	ORANGE/RED
Q	16	SPARE
R	17	PLUG
S	18	PLUG
T	19	PLUG
U	20	PLUG
V	21	PLUG
W	22	PLUG
X	23	PLUG

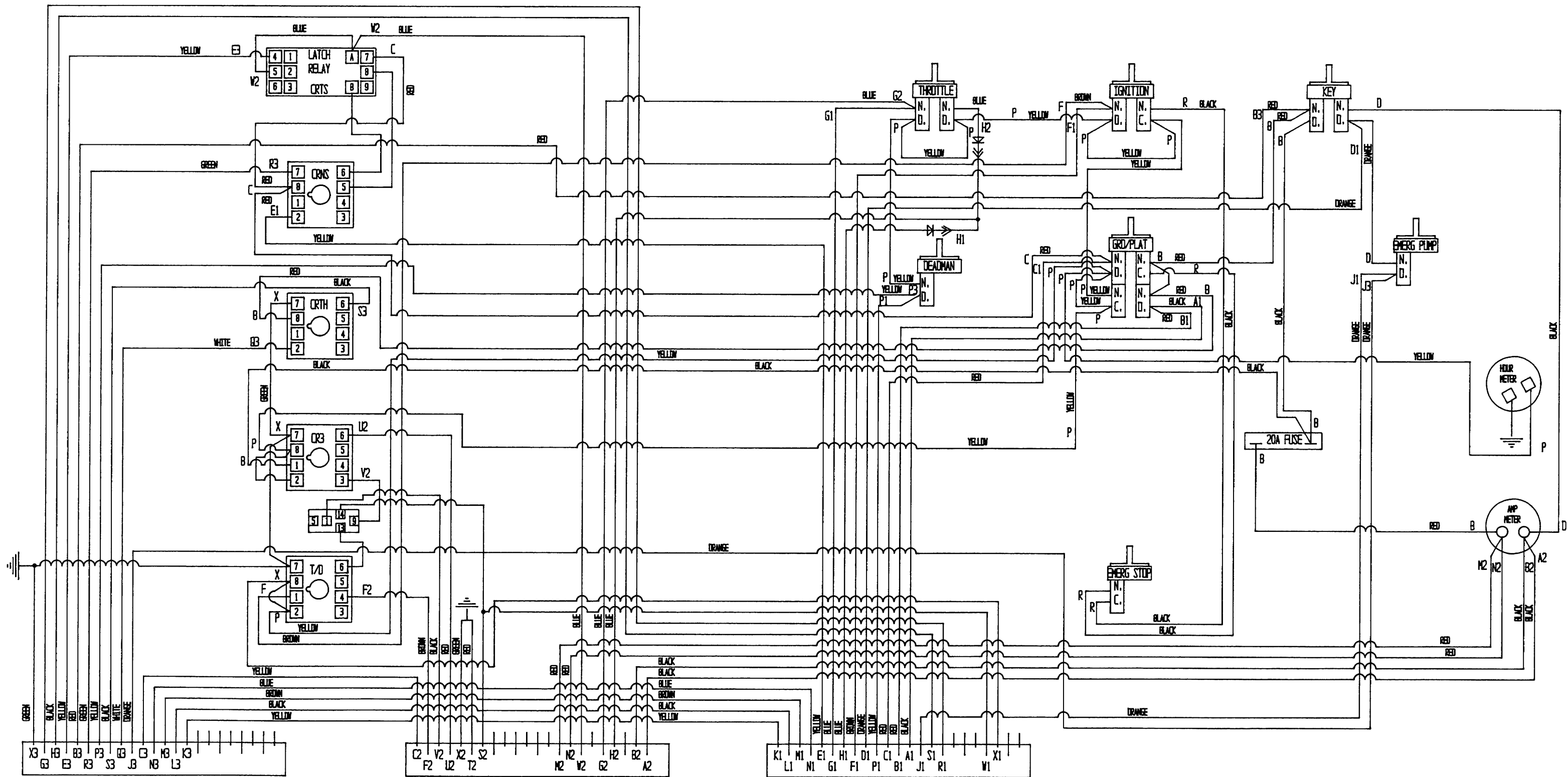

WIRE COLORS:
 GREEN
 BLACK
 YELLOW
 RED
 WHITE
 ORANGE
 BLUE
 BROWN

SIMON-AERIALS INC.
 MILWAUKEE, WI. 53224

TITLE ELECTRICAL SCHEMATICS
 AT30C/AT40C-PERKINS 103.10

REVISION _____ DRWG. NO. SDS-219825-0

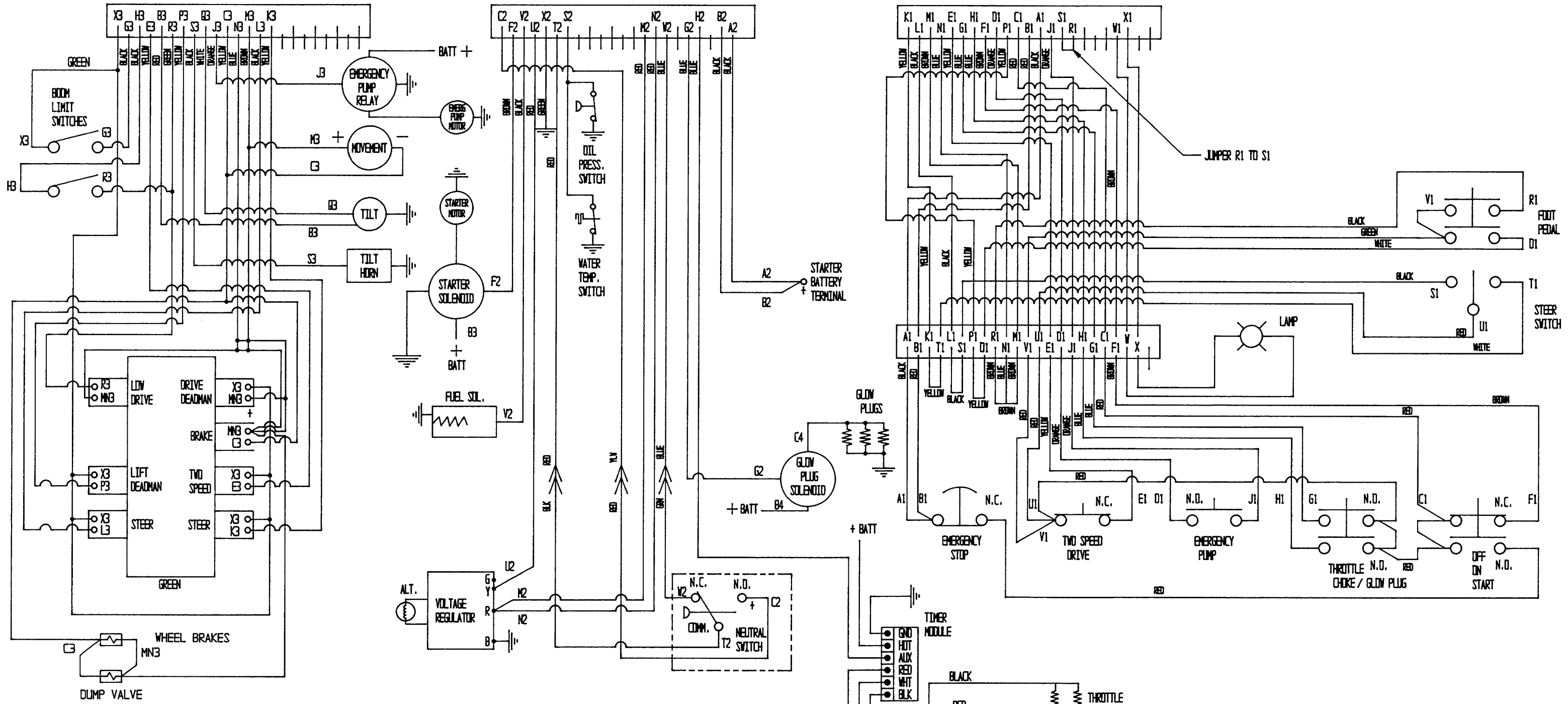

19 CONDUCTOR CONNECTIONS AT GROUND BOX

CONN. LETTER	WIRE NO.	COLOR
A	1	BLACK
B	2	RED
C	3	RED/BLACK
D	4	ORANGE
E	5	YELLOW
F	6	BROWN
G	7	BLUE
H	8	BLUE/BLACK
J	9	ORANGE/BLACK
K	10	YELLOW/BLACK
L	11	BLACK/RED
M	12	BROWN/BLACK
N	13	BROWN/RED
O	14	BLUE/RED
P	15	YELLOW/RED
Q	16	ORANGE/RED
R	17	BROWN/RED
S	18	BLACK/BLUE
T	19	BLACK/BLUE

19 CONDUCTOR CONNECTIONS AT PLATFORM

CONN. LETTER	WIRE NO.	COLOR
A	1	BLACK
B	2	RED
C	3	RED/BLACK
D	4	ORANGE
E	5	YELLOW
F	6	BROWN
G	7	BLUE
H	8	BLUE/BLACK
J	9	ORANGE/BLACK
K	10	YELLOW/BLACK
L	11	BLACK/RED
M	12	BROWN/BLACK
N	13	BROWN/RED
O	14	BLUE/RED
P	15	YELLOW/RED
Q	16	ORANGE/RED
R	17	BLACK
S	18	BLACK
T	19	WHITE

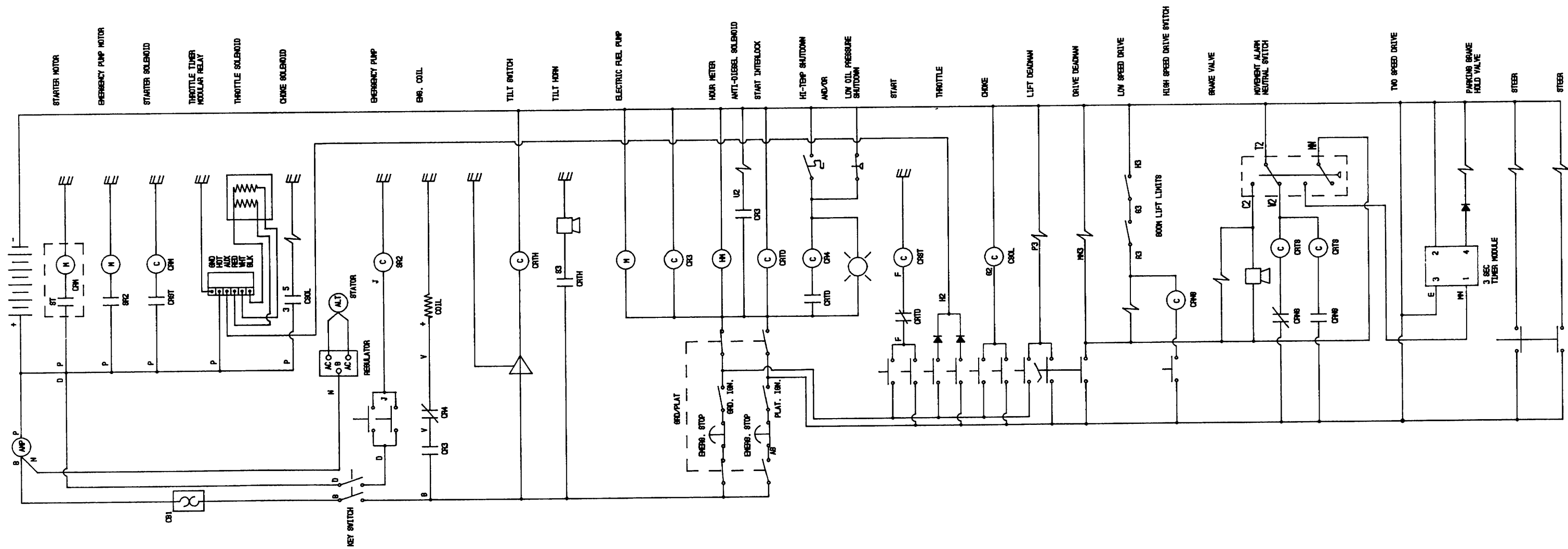

STARTER MOTOR

EMERGENCY PUMP MOTOR

STARTER SOLENOID

THROTTLE TIMER
MODULAR RELAY

THROTTLE SOLENOID

CHOKE SOLENOID

EMERGENCY PUMP

ENG. COIL

TILT SWITCH

TILT HORN

ELECTRIC FUEL PUMP

HOUR METER

ANTI-DIESEL SOLENOID

START INTERLOCK

HI-TEMP SHUTDOWN

AND/OR

LOW OIL PRESSURE
SHUTDOWN

START

THROTTLE

CHOKE

LIFT DEADMAN

DRIVE DEADMAN

LOW SPEED DRIVE

HIGH SPEED DRIVE SWITCH

BRAKE VALVE

MOVEMENT ALARM
NEUTRAL SWITCH

TWO SPEED DRIVE

PARKING BRAKE
HOLD VALVE

STEER

STEER

SIMON-AERIALS INC. MILWAUKEE, WI. 53224	
TITLE	ELECTRICAL SCHEMATIC 30 H.P. WIS. AT40C
REVISION	DRWG. NO. SDS-216331-0

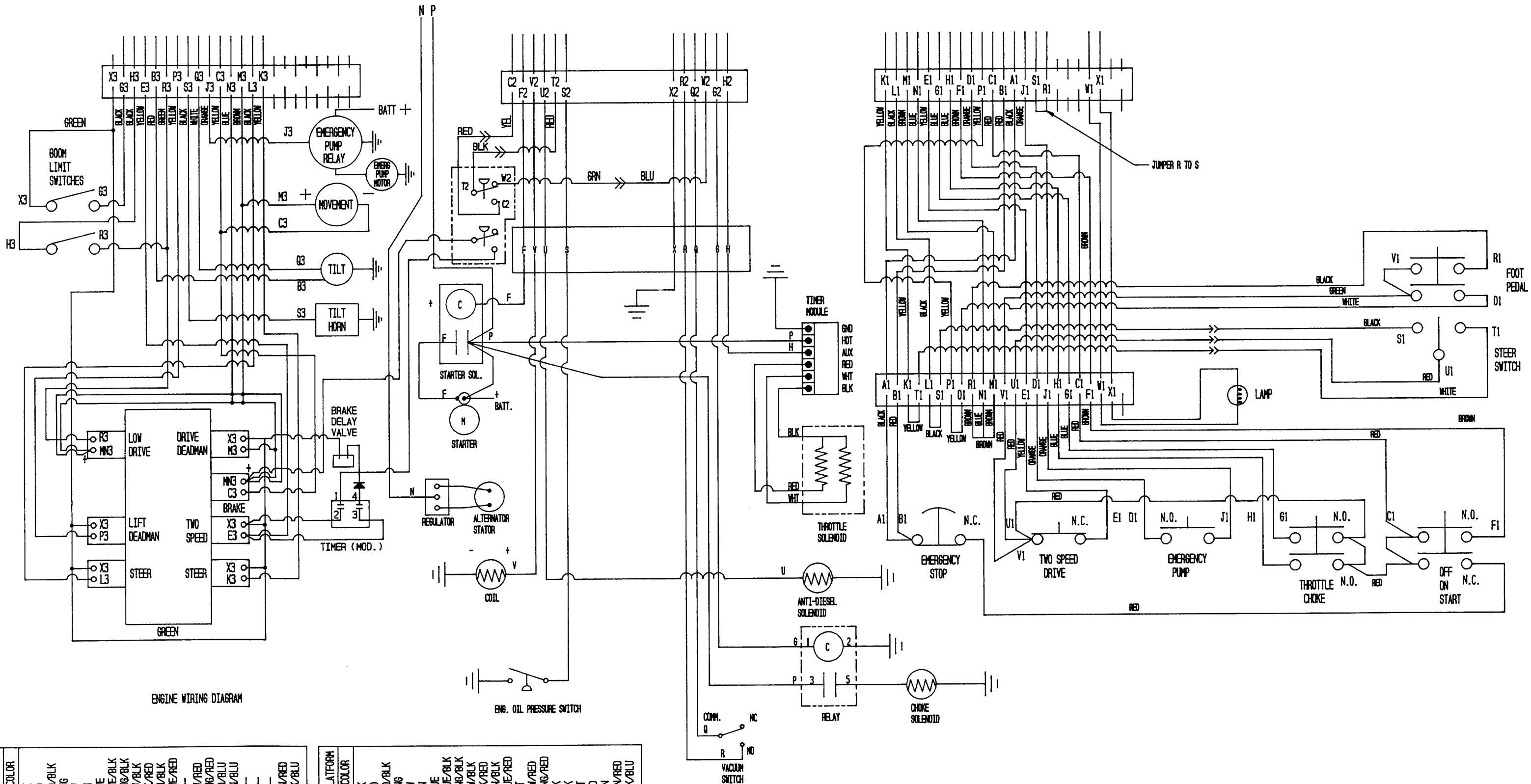

ENGINE WIRING DIAGRAM

24 CONDUCTOR CONNECTION AT GRD. BOX		
CONN. LTR	WIRE NO.	COLOR
A	1	BLK
B	2	RED
C	7	RED/BLK
D	4	ORNG
E	5	YLV
F	6	BRN
G	3	BLUE
H	8	BLUE/BLK
J	9	ORNG/BLK
K	10	YLV/BLK
L	11	BLK/RED
M	12	BRN/BLK
N	13	BLU/RED
O	PLUG	---
P	15	YLV/RED
Q	14 (SPARE)	ORNG/RED
R	18	RED/BLU
S	19	ORN/BLU
T	PLUG	---
U	PLUG	---
V	PLUG	---
W	16	BRN/RED
X	17	BLK/BLU

24 CONDUCTOR CONNECTION AT PLATFORM		
CONN. LTR	WIRE NO.	COLOR
A	1	BLK
B	2	RED
C	7	RED/BLK
D	4	ORNG
E	5	YLV
F	6	BRN
G	3	BLUE
H	8	BLUE/BLK
J	9	ORNG/BLK
K	10	YLV/BLK
L	11	BLK/RED
M	12	BRN/BLK
N	13	BLU/RED
O	FOOT SW	WHT
P	15	YLV/RED
Q	14 (SPARE)	ORNG/RED
R	FOOT SW	BLK
S	STEER SW	BLK
T	STEER SW	WHT
U	STEER SW	RED
V	FOOT SW	GRN
W	16	BRN/RED
X	17	BLK/BLU

WIRE COLORS:
 GREEN
 BLACK
 YELLOW
 RED
 WHITE
 ORANGE
 BLUE
 BROWN

SIMON-AERIALS INC.
 MILWAUKEE, WIS. 53224

TITLE: WIRING DIAGRAM
 30 H.P. WIS. GASOLINE AT40C

REVISION: _____ DRWG. NO. SDS-216330-0

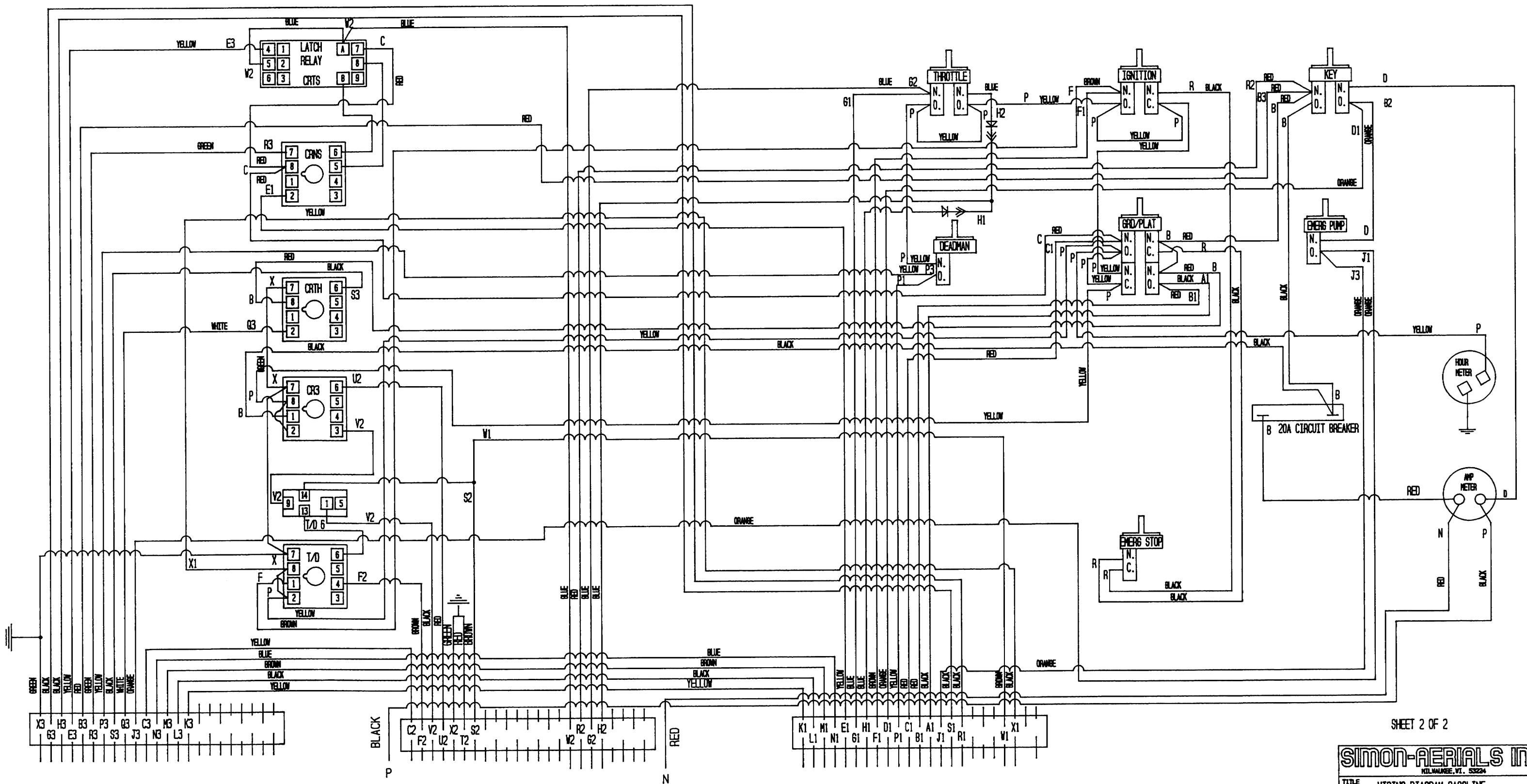

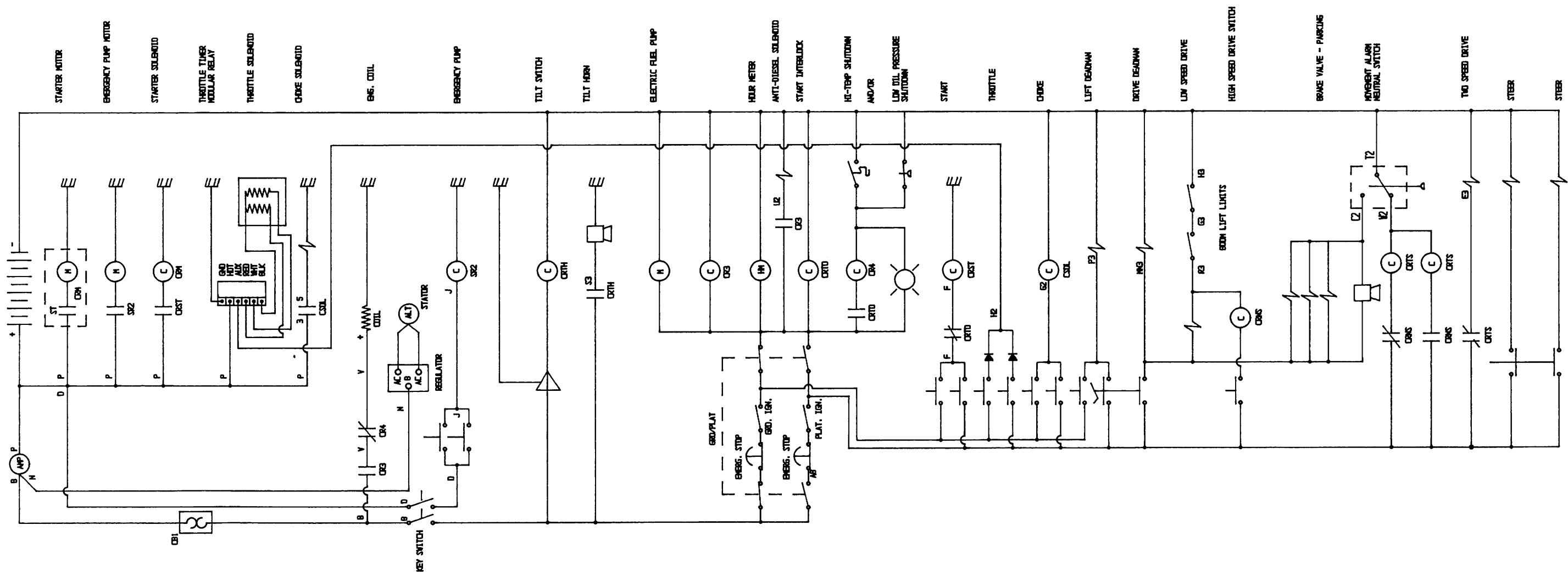

SIMON-AERIALS INC. MILWAUKEE, WI. 53224	
TITLE	ELECTRICAL SCHEMATIC 30 HP VISC. GASOLINE AT-40
REVISION	DRWG. NO. SDS-219826-0

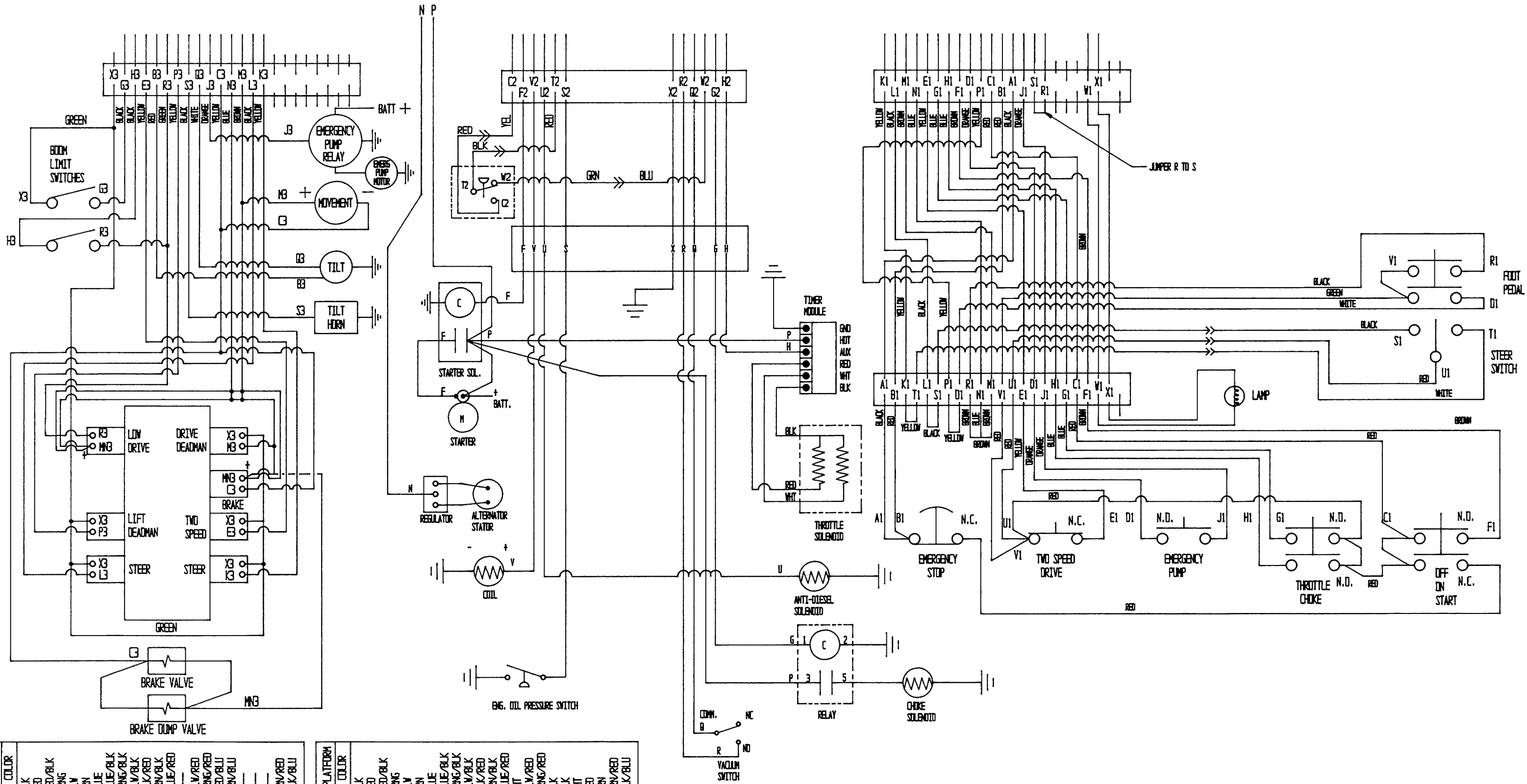

24 CONDUCTOR CONNECTION AT GND BOX

CONN. LTR	WIRE NO.	COLOR
A	1	BLK
B	2	RED
C	7	DRNG/BLK
D	4	DRNG
E	5	YLV
F	6	BRN
G	3	BLJE
H	8	BLJE/BLK
J	9	DRNG/BLK
K	10	YLV/BLK
L	12	BLK/RED
M	11	BRN/BLK
N	13	BLJE/RED
P	15	PLUG
Q	14 (SPARE)	YLV/RED
R	18	DRNG/RED
S	19	RED/BLU
T	19	DRN/BLU
U	PLUG	
V	PLUG	
W	16	BRN/RED
X	17	BLK/BLU

24 CONDUCTOR CONNECTION AT PLATFORM

CONN. LTR	WIRE NO.	COLOR
A	1	BLK
B	2	RED
C	7	DRNG/BLK
D	4	DRNG
E	5	YLV
F	6	BRN
G	3	BLJE
H	8	BLJE/BLK
J	9	DRNG/BLK
K	10	YLV/BLK
L	12	BLK/RED
M	11	BRN/BLK
N	13	BLJE/RED
P	15	PLUG
Q	14 (SPARE)	YLV/RED
R	18	DRNG/RED
S	19	RED/BLU
T	19	DRN/BLU
U	PLUG	
V	PLUG	
W	16	BRN/RED
X	17	BLK/BLU

WIRE COLORS:
 GREEN
 BLACK
 YELLOW
 RED
 WHITE
 ORANGE
 BLUE
 BROWN

SIMON-AERIALS INC.
 MILWAUKEE, WI. 53224

TITLE
 ELECTRICAL SCHEMATIC
 30 H.P. WIS. GASOLINE AT40C

REVISION
 DRNG. NO. SDS-219827-0

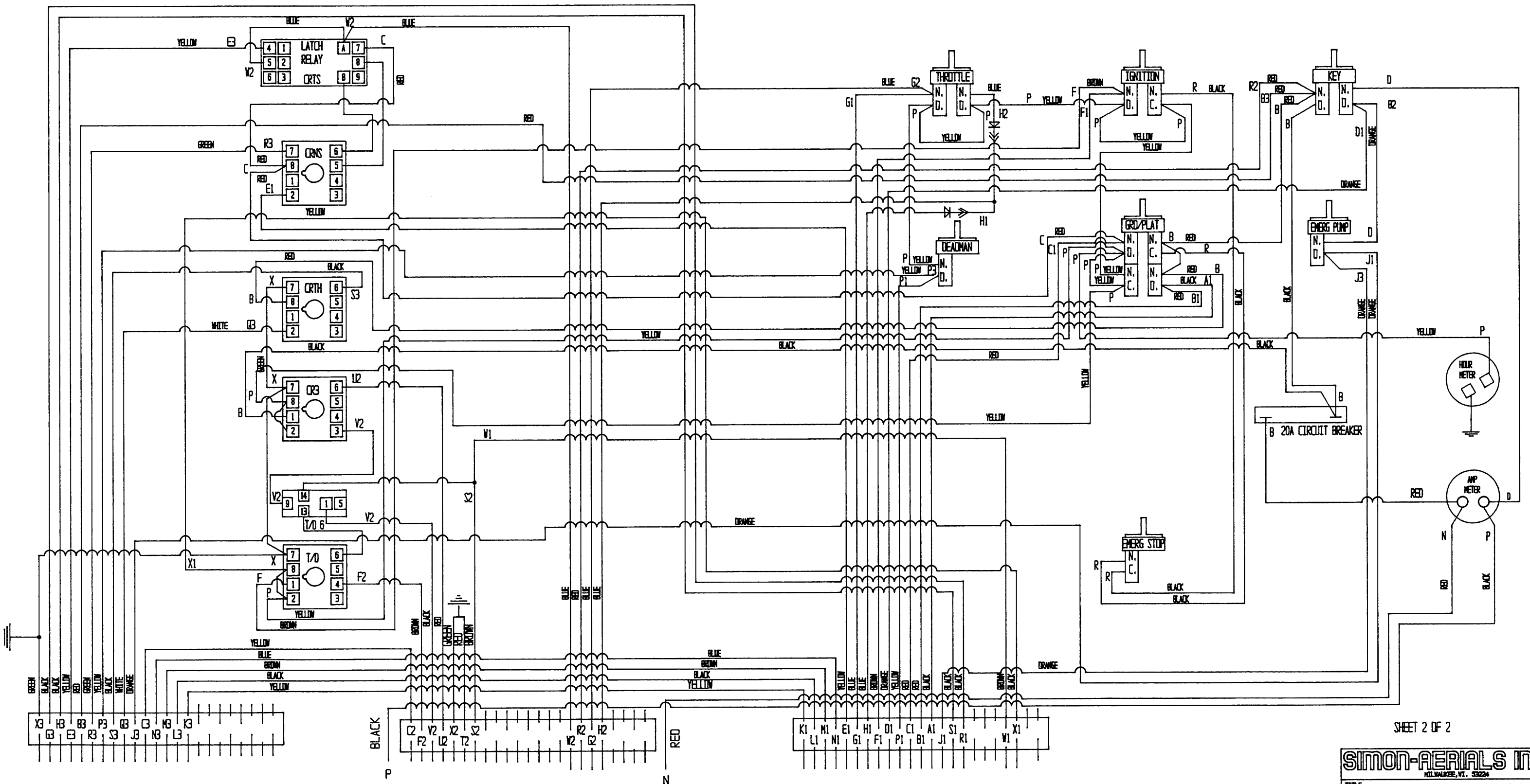

SIMON-AERIALS INC.
 MILWAUKEE, WIS. 53224

TITLE: ELECTRICAL SCHEMATIC GASOLINE
 30 H.P. WIS. AT40C

REVISION: _____ ORG. NO. SDS-219827-0

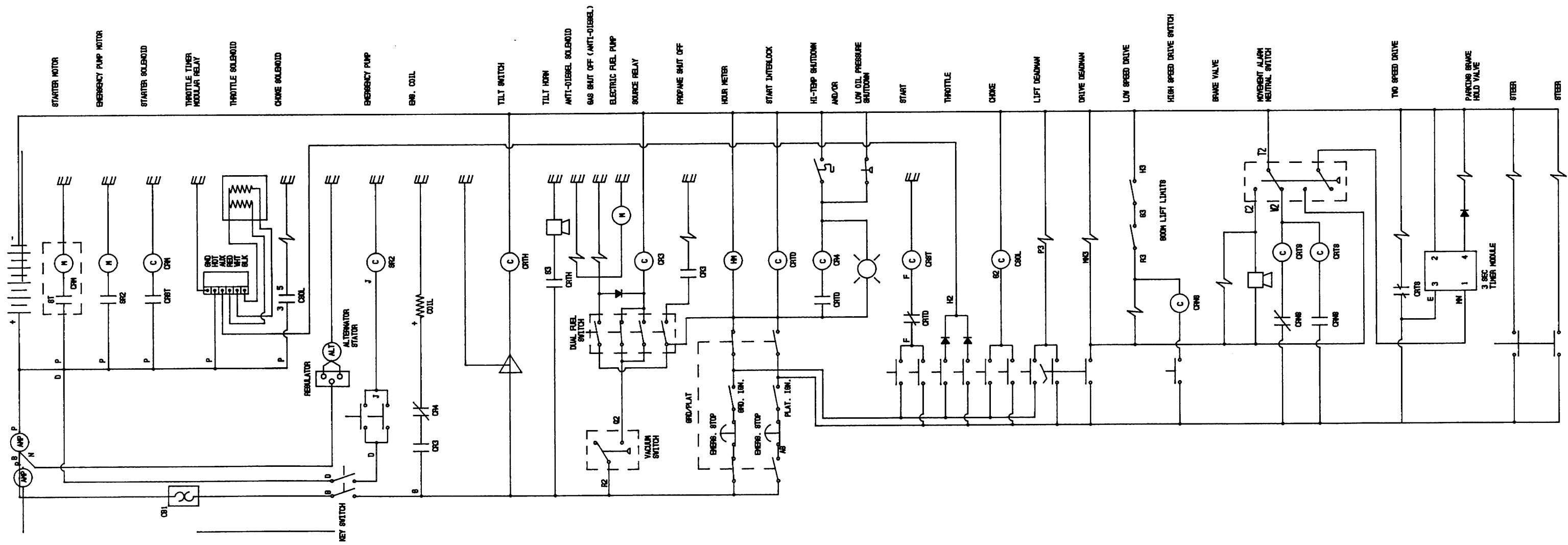

SIMON-AERIALS INC. MILWAUKEE, WI. 53224	
TITLE ELECTRICAL SCHEMATIC DUAL FUEL 30 H.P. WIS. AT40C	
REVISION	DRWG. NO. SDS-216329-0

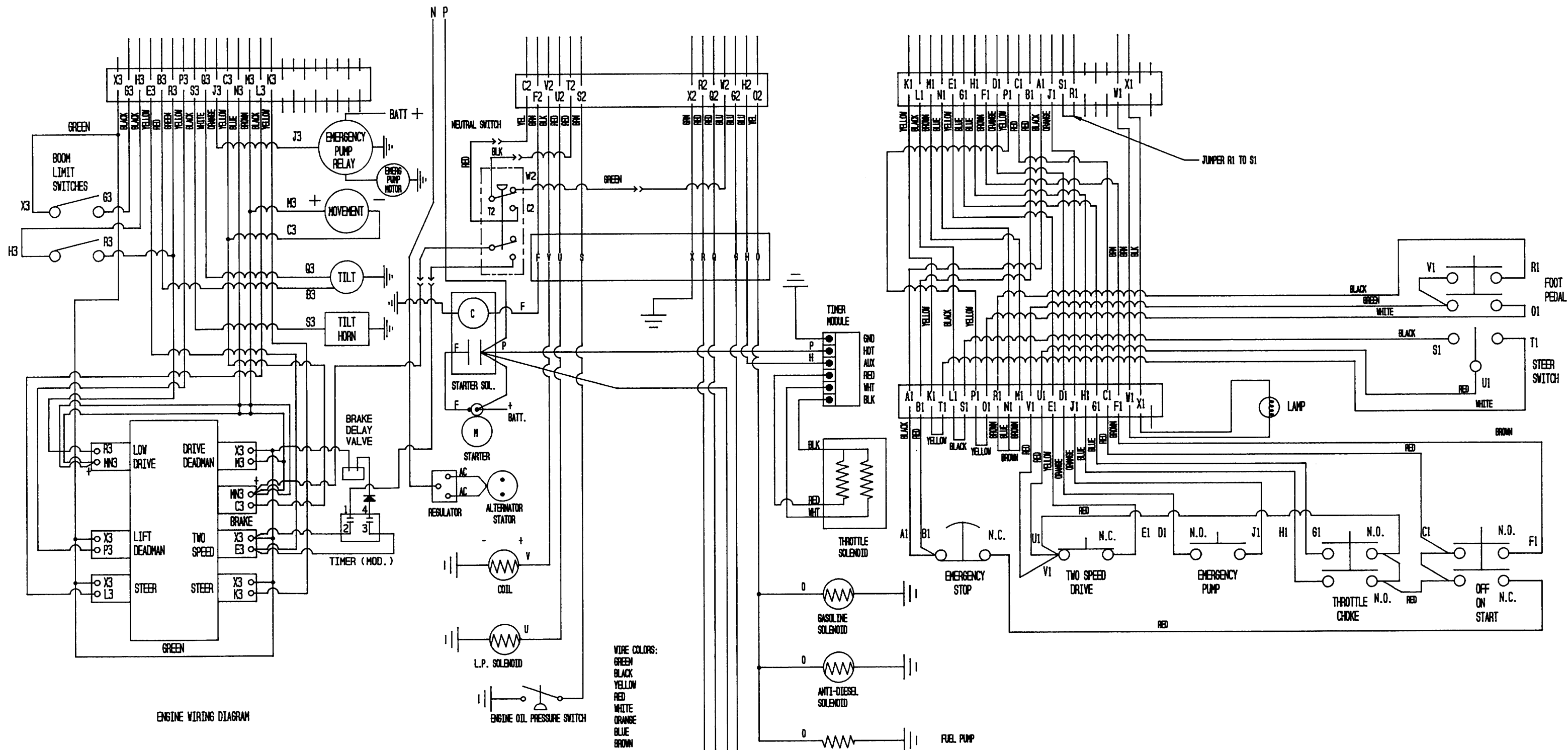

ENGINE WIRING DIAGRAM

CONN. LTR	WIRE NO.	COLOR
A	1	BLK
B	2	RED
C	7	RED/BLK
D	4	ORNG
E	5	YLV
F	6	BRN
G	3	BLUE
H	8	BLUE/BLK
J	9	ORNG/BLK
K	10	YLV/BLK
L	12	BLK/RED
M	11	BRN/BLK
N	13	BLUE/RED
O	PLUS	YLV/RED
P	14 (SPARE)	ORNG/RED
Q	18	---
R	19	---
S	PLUS	---
T	PLUS	---
U	PLUS	---
V	16	BRN/RED
W	17	BLK/BLU

CONN. LTR	WIRE NO.	COLOR
A	1	BLK
B	2	RED
C	7	RED/BLK
D	4	ORNG
E	5	YLV
F	6	BRN
G	3	BLUE
H	8	BLUE/BLK
J	9	ORNG/BLK
K	10	YLV/BLK
L	12	BLK/RED
M	11	BRN/BLK
N	13	BLUE/RED
O	FOOT SW	WHT
P	14 (SPARE)	YLV/RED
Q	15	ORNG/RED
R	FOOT SW	BLK
S	STEER SW	BLK
T	STEER SW	WHT
U	STEER SW	RED
V	FOOT SW	GRN
W	16	BRN/RED
X	17	BLK/BLU

WIRE COLORS:
 GREEN
 BLACK
 YELLOW
 RED
 WHITE
 ORANGE
 BLUE
 BROWN

SIMON-AERIALS INC.
 MILWAUKEE, WI. 53224

TITLE: WIRING DIAGRAM AT40C
 DUAL FUEL 30 H.P. WIS.

REVISION: _____ DRWG. NO. SDS-216457-0

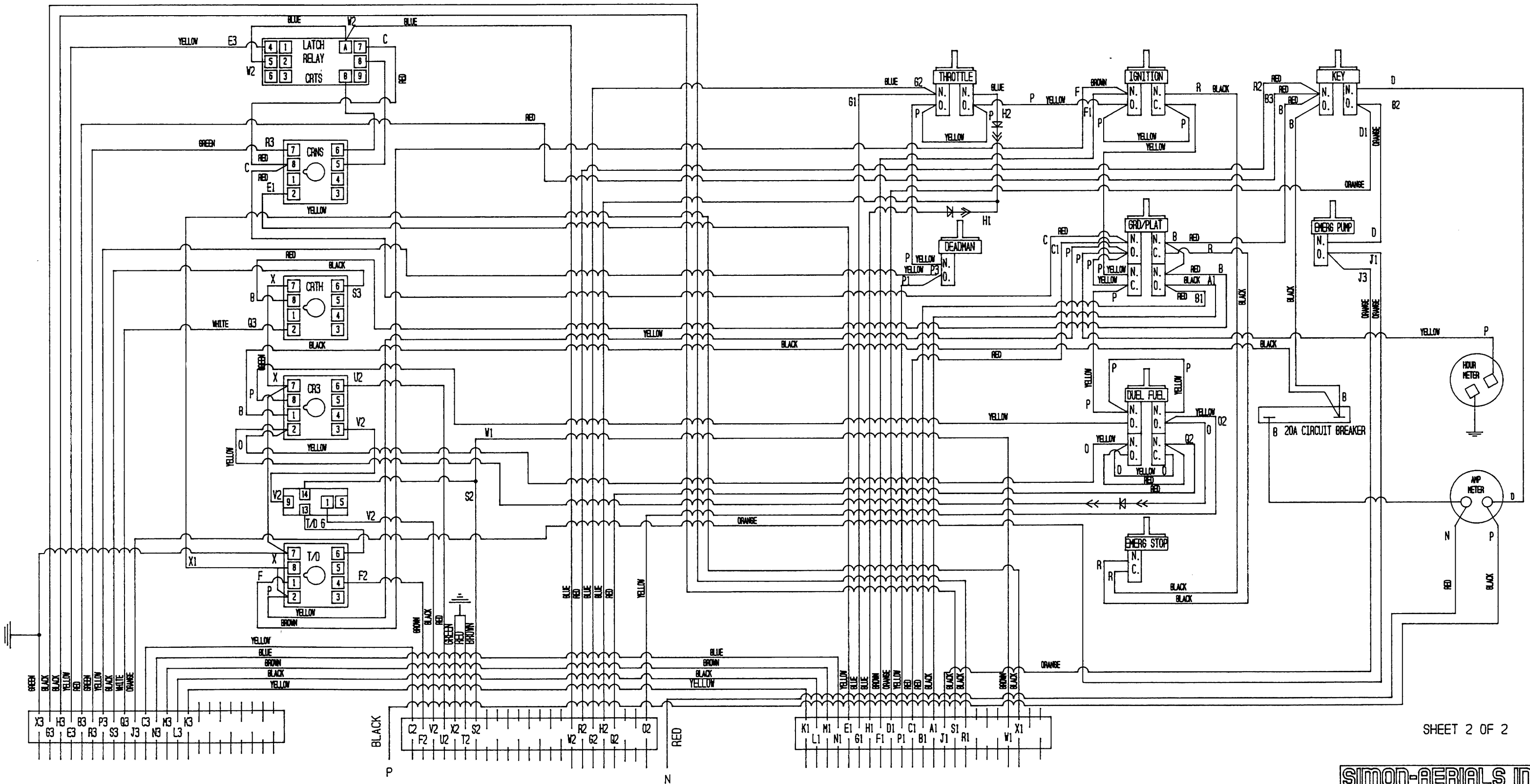

SHEET 2 OF 2

SIMON-AERIALS INC.
 MILWAUKEE, WI. 53224

TITLE: WIRING DIAGRAM DUAL FUEL
 30 H.P. WIS. AT40C

REVISION: _____ DRAW. NO.: SDS-216457-0

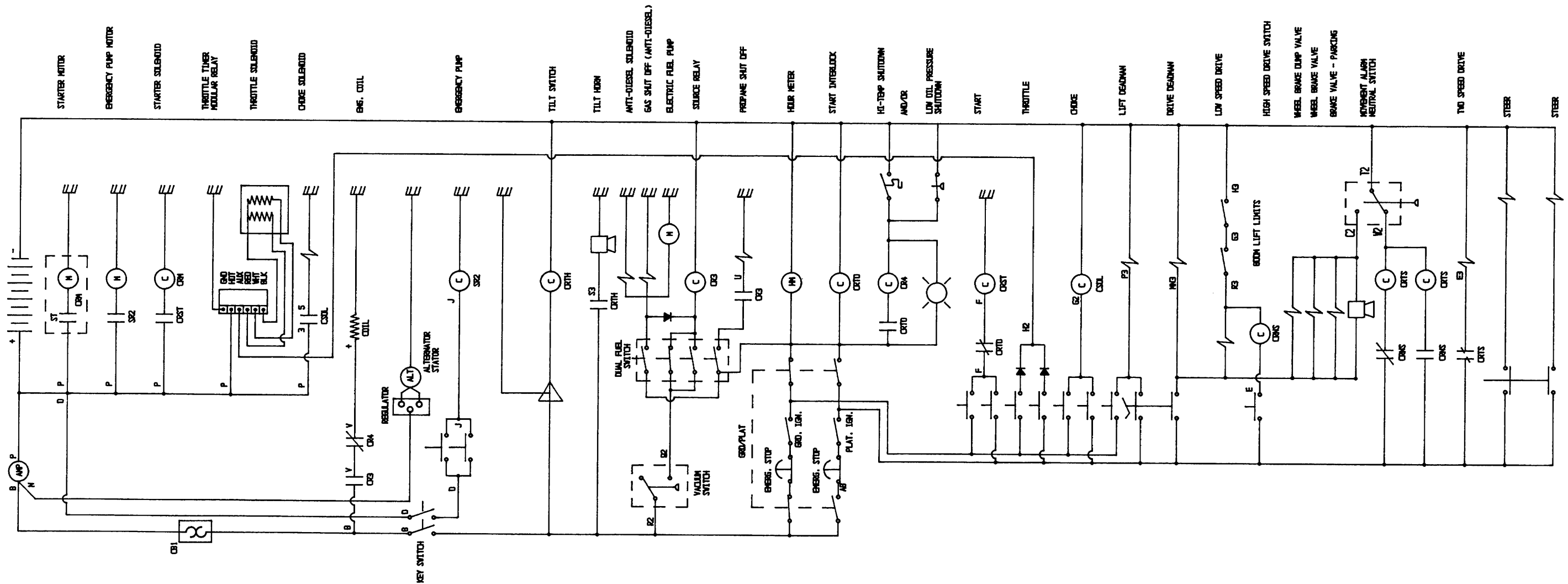

SIMON-AERIALS INC.
 MILWAUKEE, WI. 53224

TITLE	ELECTRICAL SCHEMATIC DUAL FUEL 30 H.P. V15. AT40C
REVISION	DRWG. NO. SDS-219828-0

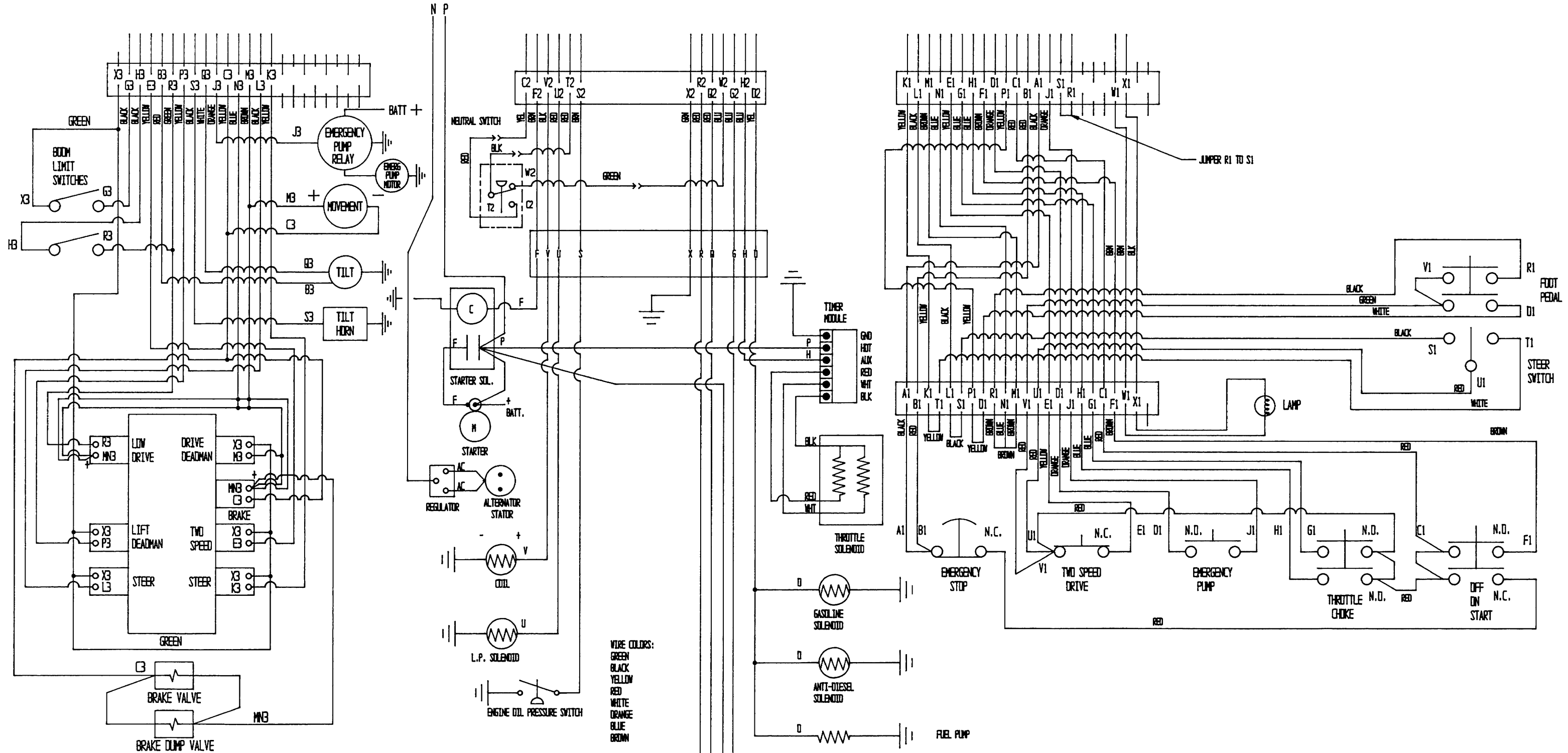

WIRE COLORS:
 GREEN
 BLACK
 YELLOW
 RED
 WHITE
 ORANGE
 BLUE
 BROWN

24 CONDUCTOR CONNECTION AT GROUND BOX

CONN. LTR	WIRE NO.	COLOR
A	1	BLK
B	2	RED
C	7	RED/BLK
D	4	DRNG
E	5	YLV
F	6	BRN
G	3	BLUE
H	8	BLUE/BLK
J	9	DRNG/BLK
K	10	YLV/BLK
L	12	BLK/RED
M	11	BRN/BLK
N	13	BLUE/RED
D	13	PLUG
P	15	YLV/RED
Q	14 (SPARE)	DRNG/RED
R	18	---
S	19	---
T	19	PLUG
U	19	PLUG
V	16	---
W	16	BRN/RED
X	17	BLK/BLU

24 CONDUCTOR CONNECTION AT PLATFORM

CONN. LTR	WIRE NO.	COLOR
A	1	BLK
B	2	RED
C	7	RED/BLK
D	4	DRNG
E	5	YLV
F	6	BRN
G	3	BLUE
H	8	BLUE/BLK
J	9	DRNG/BLK
K	10	YLV/BLK
L	12	BLK/RED
M	11	BRN/BLK
N	13	BLUE/RED
D	13	PLUG
P	15	YLV/RED
Q	14 (SPARE)	DRNG/RED
R	18	---
S	19	---
T	19	PLUG
U	19	PLUG
V	16	---
W	16	BRN/RED
X	17	BLK/BLU

SIMON-AERIALS INC.
 MILWAUKEE, WIS. 53224

TITLE
 ELECTRICAL SCHEMATIC AT40C
 DUAL FUEL 30 H.P. WIS.

REVISION 05-05-92 DRG. NO. SDS-219912-0

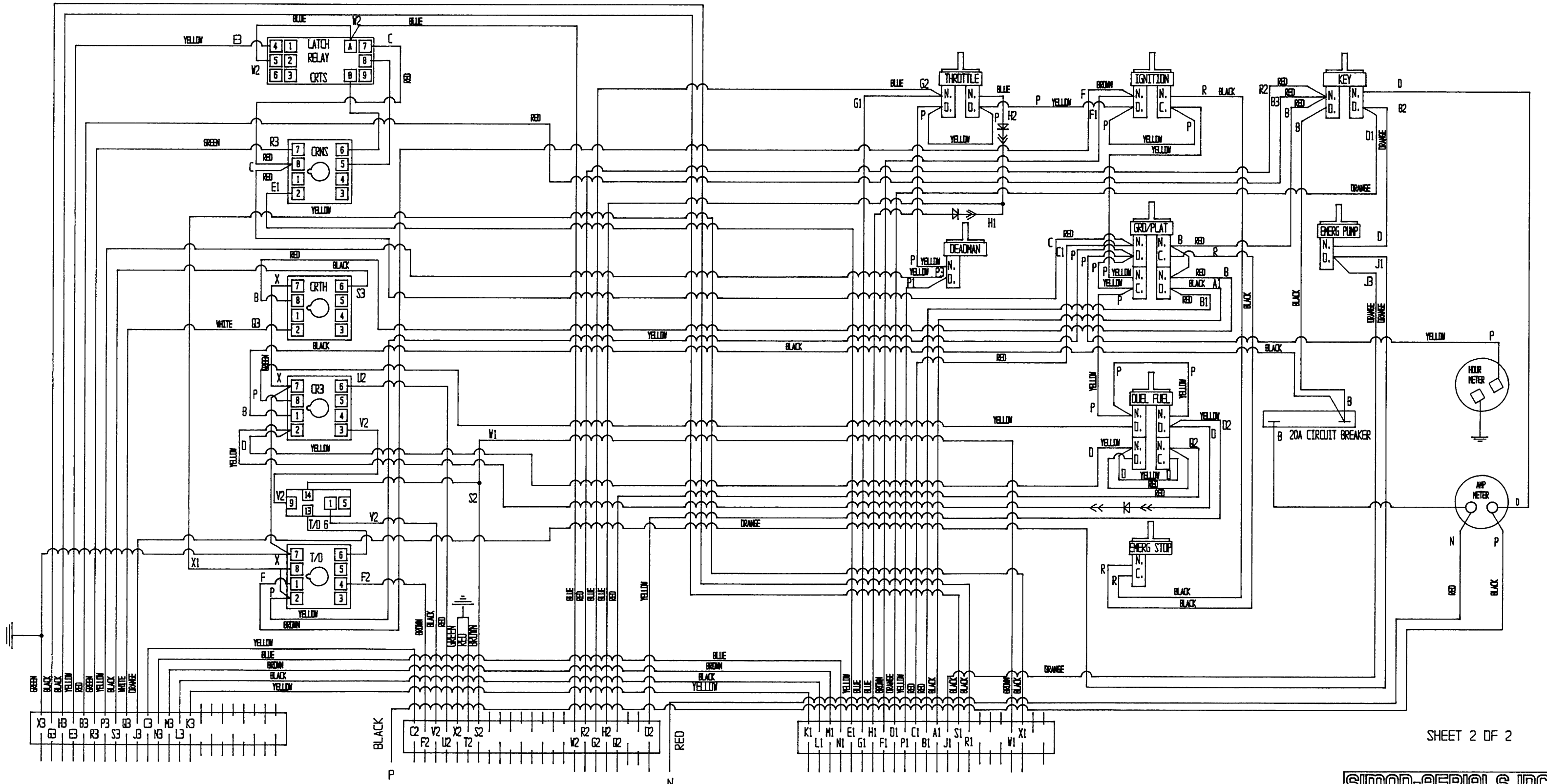

SIMON-AERIALS INC.
 MILWAUKEE, WI. 53224

TITLE: ELECTRICAL SCHEMATIC DUAL FUEL
 30 H.P. WIS. AT40C

REVISION: _____ DRG. NO. SDS-219912-0

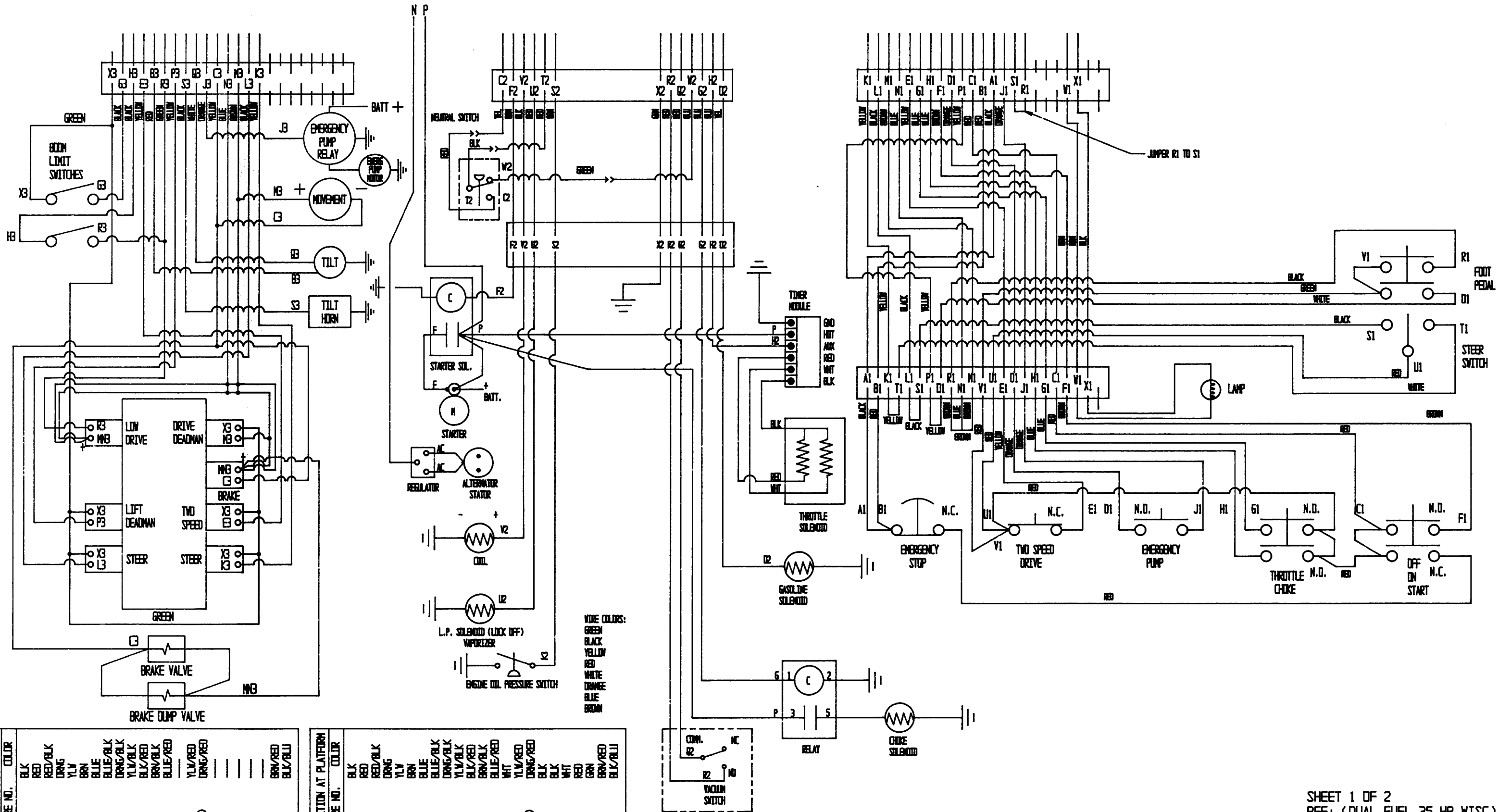

24 CONDUCTOR CONNECTION AT GND BOX

CONN. LTR	WIRE NO.	COLOR
A	1	BLK
B	2	RED
C	3	RED/BLK
D	4	DRNG
E	5	YLV
F	6	BRN
G	7	BLU
H	8	BLU/BLK
J	9	DRNG/BLK
K	10	YLV/BLK
L	11	BLK/RED
M	12	BRN/BLK
N	13	BLU/RED
P	15	YLV/RED
Q	14 (SPARE)	DRNG/RED
R	16	---
S	17	---
T	18	---
U	19	---
V	20	PLUG
W	21	PLUG
X	22	PLUG
	23	PLUG
	24	BRN/RED
		BLK/BLU

24 CONDUCTOR CONNECTION AT PLATFORM

CONN. LTR	WIRE NO.	COLOR
A	1	BLK
B	2	RED
C	3	RED/BLK
D	4	DRNG
E	5	YLV
F	6	BRN
G	7	BLU
H	8	BLU/BLK
J	9	DRNG/BLK
K	10	YLV/BLK
L	11	BLK/RED
M	12	BRN/BLK
N	13	BLU/RED
P	15	WHT
Q	14 (SPARE)	YLV/RED
R	16	DRNG/RED
S	17	BLK
T	18	BLK
U	19	WHT
V	20	RED
W	21	GRN
X	22	BRN/RED
	23	BLK/BLU
	24	---

WIRE COLORS:
 GREEN
 BLACK
 YELLOW
 RED
 WHITE
 BROWN
 BLUE
 BRN

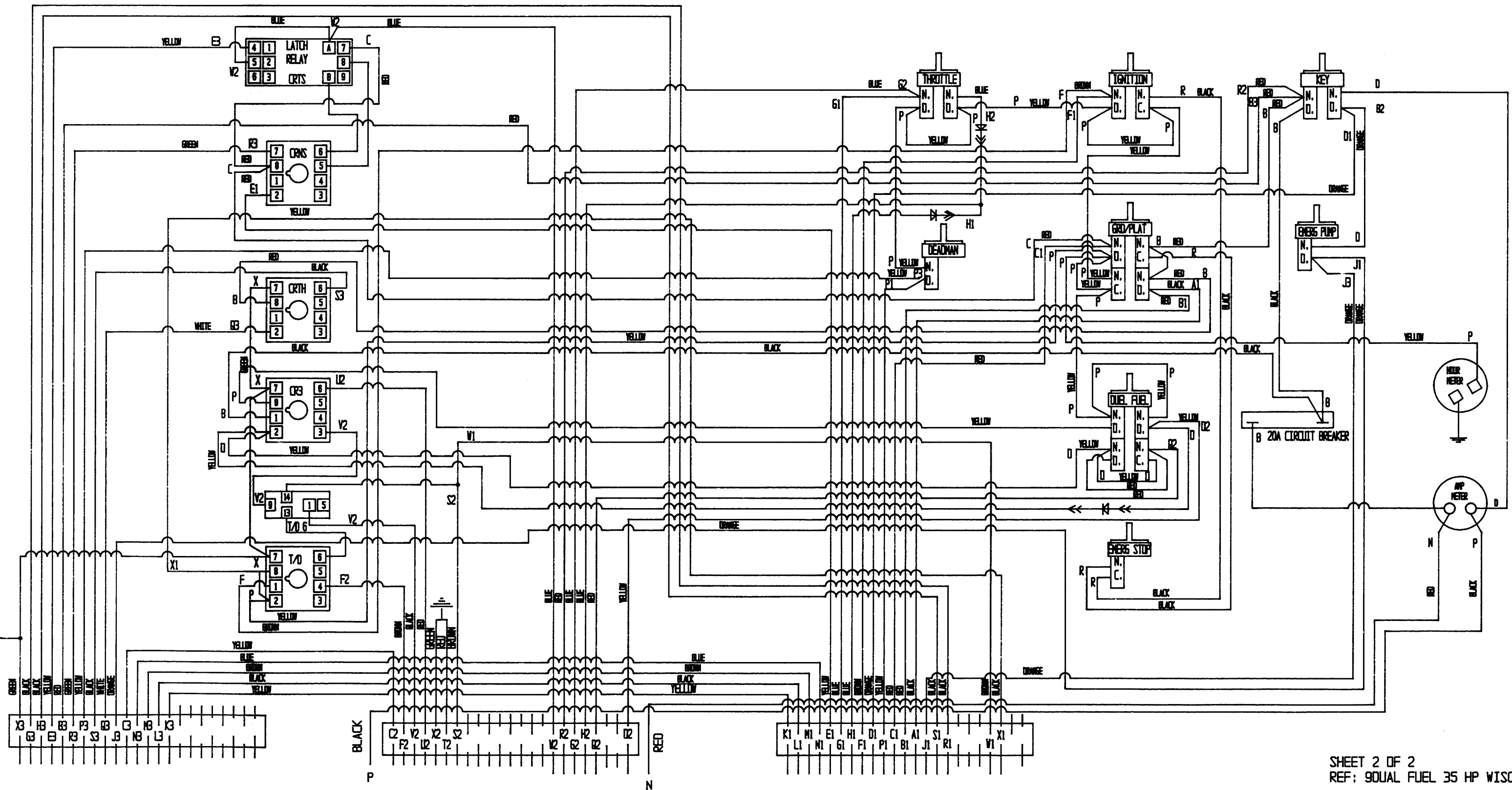

SHEET 2 OF 2
 REF: 90UAL FUEL 35 HP WISC)

SIMON AERIALS INC.
WILMINGTON, VT. 05394

TITLE: ELECTRICAL SCHEMATIC
 AT 30 & 40C, SAI GAS EAGLE

REVISED: REL/10-26-92 DWG. NO. SDS-2307000

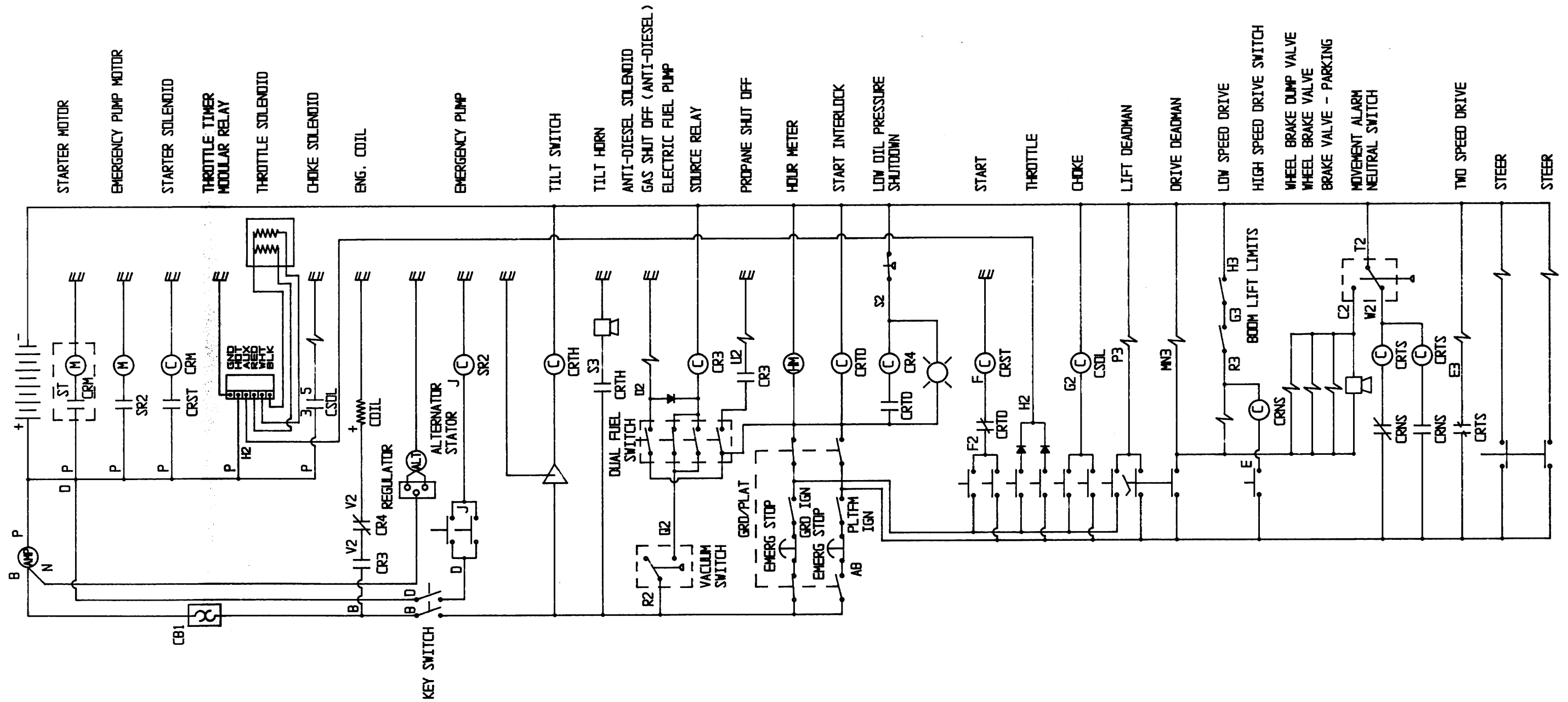

- STARTER MOTOR
- EMERGENCY PUMP MOTOR
- STARTER SOLENOID
- THROTTLE TIMER MODULAR RELAY
- THROTTLE SOLENOID
- CHOKE SOLENOID
- ENG. COIL
- EMERGENCY PUMP
- TILT SWITCH
- TILT HORN
- ANTI-DIESEL SOLENOID
- GAS SHUT OFF (ANTI-DIESEL)
- ELECTRIC FUEL PUMP SOURCE RELAY
- PROPANE SHUT OFF
- HOURL METER
- START INTERLOCK
- LOW OIL PRESSURE SHUTDOWN
- START
- THROTTLE
- CHOKE
- LIFT DEADMAN
- DRIVE DEADMAN
- LOW SPEED DRIVE
- HIGH SPEED DRIVE SWITCH
- WHEEL BRAKE DUMP VALVE
- WHEEL BRAKE VALVE
- BRAKE VALVE - PARKING
- MOVEMENT ALARM NEUTRAL SWITCH
- TWO SPEED DRIVE
- STEER
- STEER

REF: (DUAL FUEL 35 HP WISC.)

SIMON AERIALS INC.
WELLSVILLE, VT. 05224

TITLE ELECTRICAL SCHEMATIC
 AT 30 & 40C, SAI GAS EAGLE

REVISION REL/10-26-92 DRAW. NO. SDS-2307010