

SPX527

max 2700 kg

4150 x 1100 x 1960 mm

max 18.3 m

max 11.2 m

Whether it is a small job or a big construction site, the SPX527 is the mini crane par excellence: Reliable and safe, it adapts to any kind of job.



Technical Information

Dimension	L x W x H	4150 x 1100 x 1960 mm
Stab Area		4160 x 4160 mm

		Kg
Crane & Options Weights	SPX527CDH	3600
	/	
	3T-D8	30
	PP400-4D AUX	30
	JIB800G	55
	JIB600.2H	210
MR800.4	230	
JIB301GR	200	
JIB302GR	210	

SPX527CDH	Diesel Engine	KUBOTA D11 05-E3B	18.7 kW 25 Hp
-----------	---------------	-------------------	------------------

Speed		2 km/h
-------	--	--------

Gradeability		25°
--------------	--	-----



Electric Power Pack

AUX	4 kW - 3F 400 VAC 50 Hz
AUX	4 kW - 1F 110 VAC 60 Hz

Max. Track Load

	0.53 kg/cm²
--	-------------

Max. Outrigger Load

MAX	2700 kg
-----	---------

Winch & Fall Stages

Main Winch	900 kg 60 m - Ø 8 mm 40,6 m/min.
------------	--

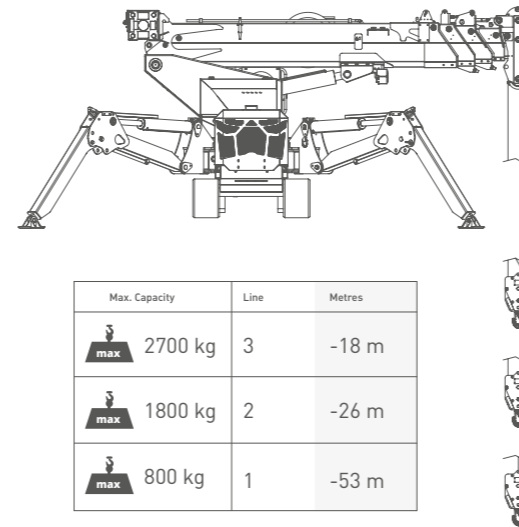

Max. Capacity	Line	Metres
max 2700 kg	3	-18 m
max 1800 kg	2	-26 m
max 800 kg	1	-53 m

Load Chart

000 Capacity with jib
(000) Pick&Carry

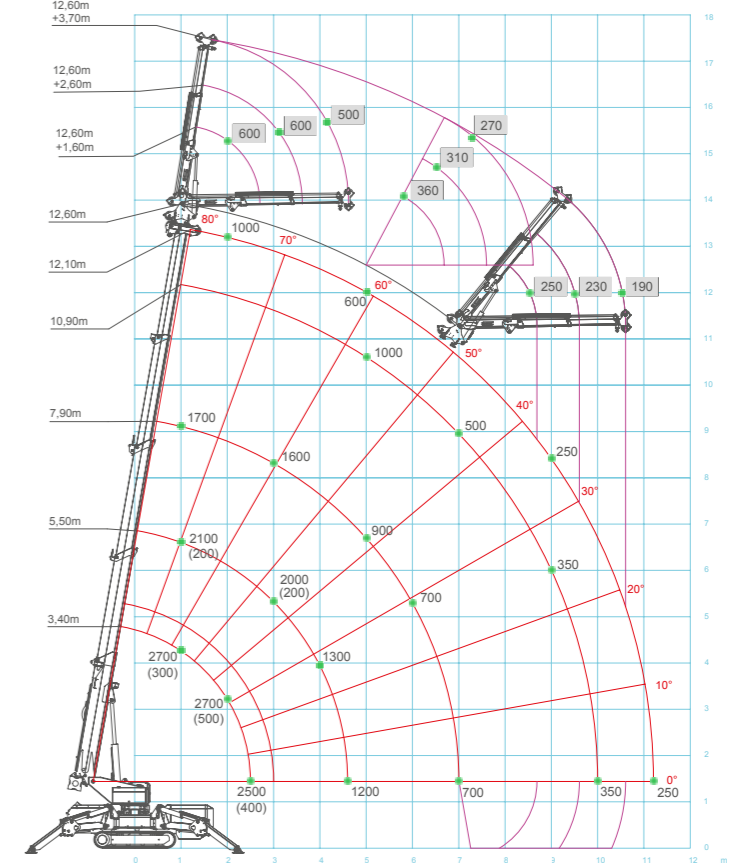

Dimensions

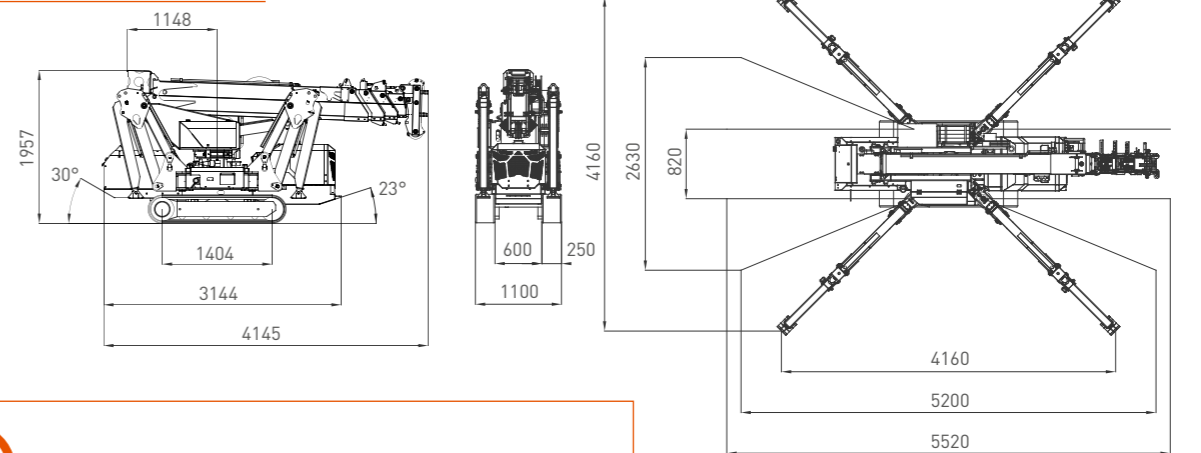

Crane Options

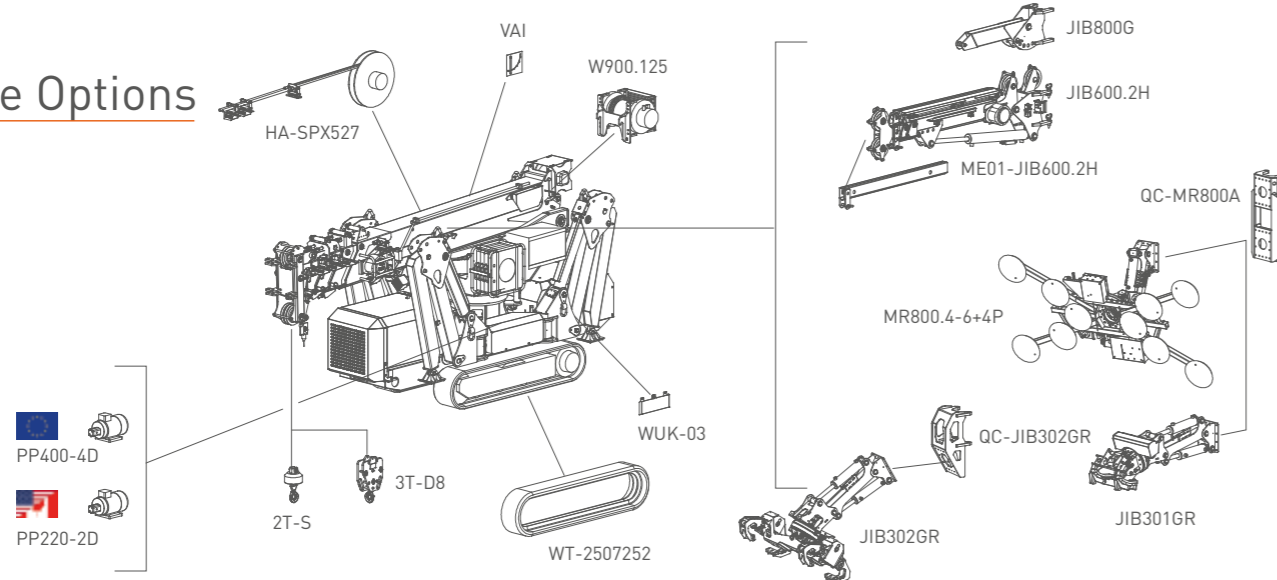

- A2B
- BPI
- CCI
- DTC
- EKT
- GSC
- LMI
- P&C
- PPA
- SCI
- TH
- VW
- RCD
- 2SW
- 2ST

Tools Configurations

	JIB800G	JIB600.2H*	MR800.4-6+4P	JIB301GR	JIB302GR
max	800 kg	600 kg	800 kg	300 kg	300 kg
max	800 kg @ 13.5m	500 kg @ 17.5m	400 kg @ 14m	300 kg @ 15m	300 kg @ 15m
max	250 kg @ 11m	190 kg @ 10.5m	150 kg @ 9m	300 kg @ 8m	300 kg @ 8m

* Manual extension (stinger) available