

# AMERICAN TOPLIFT.COM



General  
Catalogue

## ATL TRUCK CRANES

ATL truck cranes series is compact and lightweight. Their optimum ratio of lifting power to dead weight combined with their outreach make them ideal assistants for a wide range of applications. The square bolt pattern of ATL series for quick fastening system for easy for installation is appreciate by lorry body maker. This feature combine with its weight makes it possible to position the crane base in any of 4 positions during installation. It also makes it easy to change the base position later for operation convenience.



### ATL TRUCK CRANES | STANDARD



#### Stabilizer system

Offer a high degree of stability even for small vehicles. The use of different support cylinders enables the stabilizer system to be adapted to the vehicle in an ideal manner.

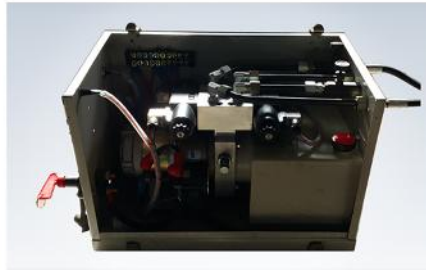

#### Power Packs

With 1.5 Kw Or 3.0 Kw Of power. Specially designed for 12 v or 24 v power packs. They are protected inside IP65 protection case and are easy to disassemble for easy maintenance.



#### Slewing Mechanism

Maximum performance in Minimal space. Greater efficiency thanks to lightweight and maintenance-friendly worm drive. This allows precise slewing of the crane.



#### Control Console

The control console can be positioned as desired as it can extend up to 2m. Operator will have clear view during operation thus will improve safety.



#### Internal Oil Feeds

The internal oil ducts enable a compact extension boom system design and ensure maximum protection against damage.



#### Hydraulic Overload Protection

In-built safety function. When the load limits are reached, all movements that could further increase the lifting moment are stopped.

A crane for every needs  
Now everybody can lift

ATL  
Cranes

## ATL 250 | SPECIFICATION

Technical data:	ATL 250
Maximum lifting capacity:	2400 kg
Telescopic boom	2 hydraulic extension - 1 manual extension
Slewing angle	360°
Net weight	360 kg
Design standard	DIN 15018 / EN 12999
<b>Power Pack:</b>	
Power	12V 100A
Motor	3 kW
Operation	electric via pushbutton on hand-held unit
Oil flow	8 l / min
Working pressure	175 bar
Oil tank capacity	12 l

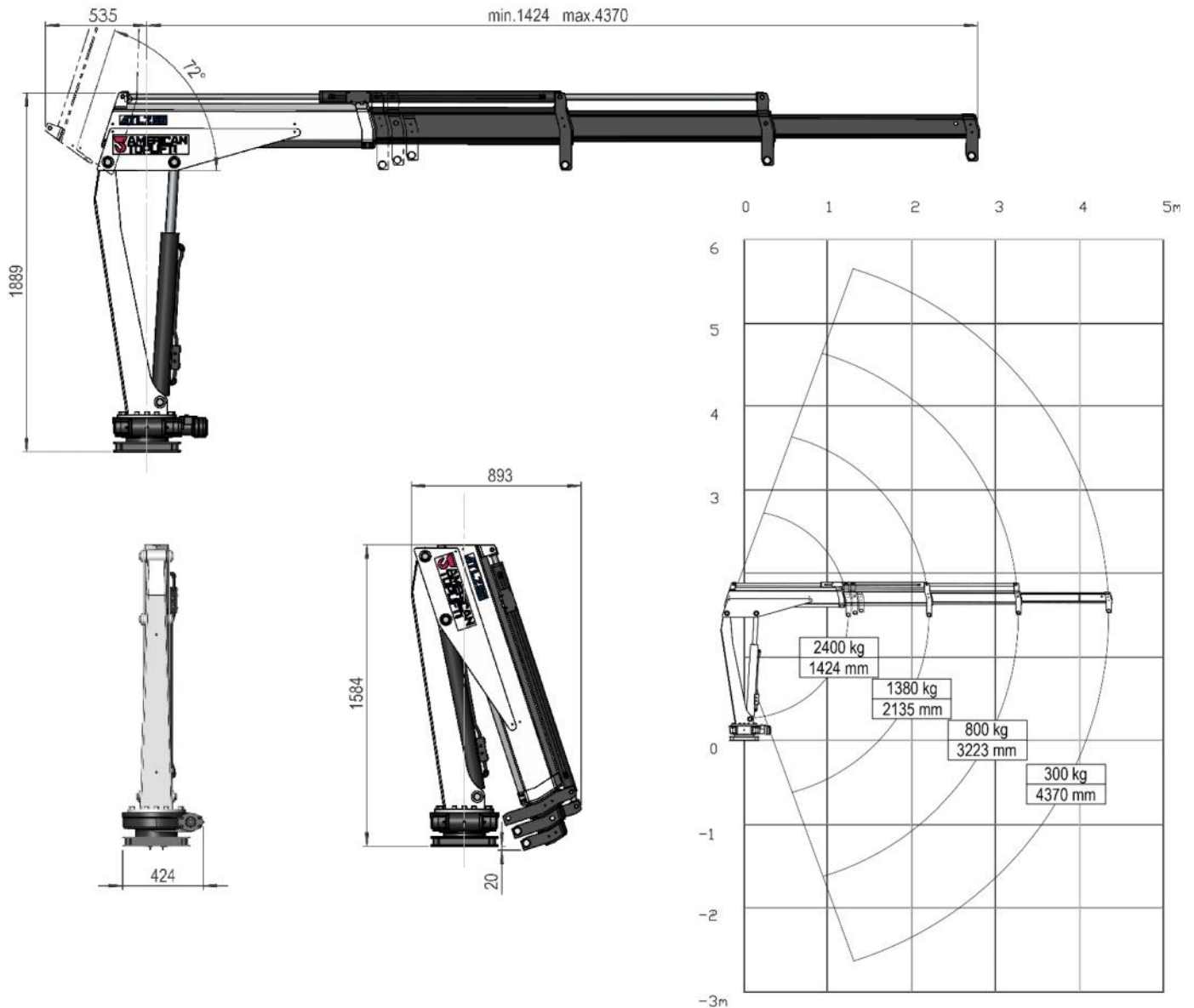

A crane for every needs  
Now everybody can lift

ATL  
Cranes

## ATL 100 | SPECIFICATION

Technical data:	ATL 100
Maximum lifting capacity:	1380 kg
Telescopic boom	1 hydraulic extension - 1 manual extension
Slewing angle	360°
Net weight	360 kg
Design standard	DIN 15018 / EN 12999
<b>Power Pack:</b>	
Power	12V 100A
Motor	2.2 kW
Operation	electric via pushbutton on hand-held unit
Oil flow	8 l / min
Working pressure	150 bar
Oil tank capacity	12 l

