

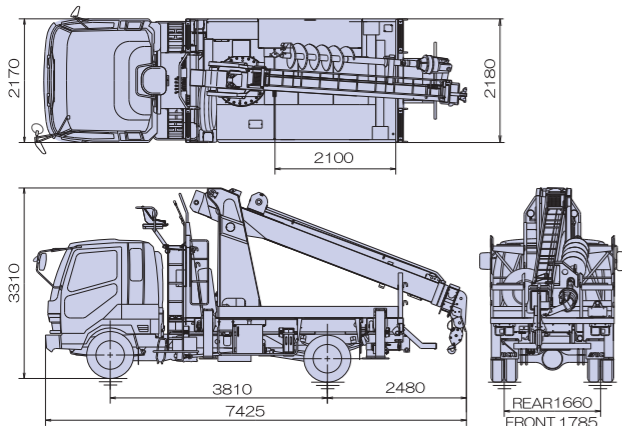

VEHICLE DIMENSIONS

These dimensions may vary depending on the chassis.



WORKING RANGE CHART

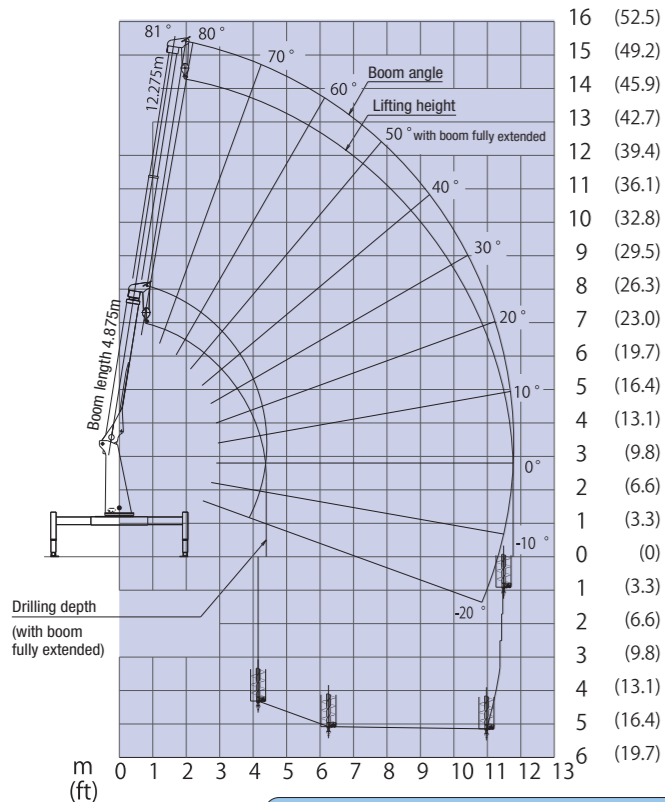

RATED LOAD CHART

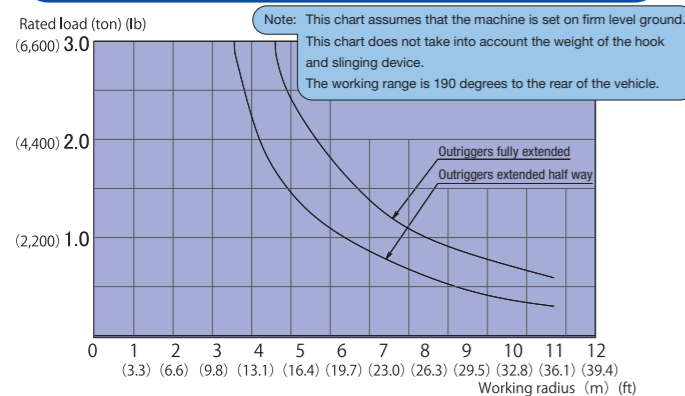

MAJOR SPECIFICATIONS

● MODEL	
Model No.	D-70A
Model Name	Crane Borer
● LIFTING SPECIFICATIONS	
Maximum Load	3.0ton (6,600lbs)
Capacity	3.0ton x 4.5m (6,600lbs x 15.1ft)
Auger Range	190° from rear (95 degrees to left and right)
Work Range	0.80 - 11.70m (2.6 - 38.4ft)
Maximum lifting height	14.15m (46.4ft)
● AUGER	
Work Radius	4.16 - 11.40m (13.6 - 37.4ft)
Max drilling depth	5.2m (17.1ft)
Wok Range	190° from rear (95 degrees to left and right)
Drilling Diameter	0.45m (1.47ft)
Torque of Auger	725kgf-m (5,240ft-lb)
● OUTRIGGER	
Extended Width	Front: 1,980 - 3,950 (78 - 155 in) Rear: 1,980 - 3,780 (78 - 149 in)
Outrigger Stroke	Front: 980mm (38.6in) Rear: 900mm (35.4in)
Jack Stroke	440mm (17.3in)
● ROTATION DEVICE	
Rotation Angle	360 degrees
Rotation Speed	2.5rpm (with pump at 2,000rpm)
● BOOM	
Length	4.875 - 12.275m (16 - 40.3ft)
Angle	-20 - 81
Elevation Speed	Full stroke: 23sec (raising), 26sec (lowering) (pump at 2000rpm)
Extension Stroke	3.70m x 2 (8.86ft x 2)
Extension Speed	Full stroke: 20sec (extension) 24sec (retraction) (pump at 2000rpm)
● WINCH	
Hook Speed	Up: 55m/min (180ft/min) Down: 40m/min (130ft/min) (pump at 2000rpm)
Wire Rope	T7 x 7 + Fi(20) class BΦ10(mm)
Number of Wires	2
● SAFETY DEVICE	
Hydraulic Circuit (Hydraulic relief valve, Holding valves on elevation and extension cylinders, Auger over winding prevention device, Winch over winding prevention device), Parallel hook movement device, Alarm horn, Hook stopper, Load meter, Boom angle meter, Auger holding device.	
● OTHER DEVICE	
Engine start and stop device, Jack check valve guard, Variable pole support horns, Water tank with electric pump, Hydraulic power outlet, Toolbox, Work light.	
● STANDARD ACCESSORIES	
Jack base, Tyre chocks, Grounding wire wheel, Sling.	
● OPTIONAL ACCESSORIES	
Auger setting pin, Pole extractor, Rear reflectors, Partition boards, Rock bit, Pole grabs.	
● GRADES	
STD L (Equipped with multi-operation lever) C (Equipped with oil cooler) LC (Equipped with multi-operation lever and oil cooler)	
● VEHICLE	
HINO GT8J 4WD 13T GVM	



HIGH-POWERED CRANE BORER POLEMASTER D70A



A STURDY AND POWERFUL MACHINE, COMBINING BOTH SAFETY AND EASE OF OPERATION



STURDY BODY TO WITHSTAND VIGOROUS USE, POWERFUL TORQUE TO IMPROVE EFFICIENCY, EXCELLENT MANOEUVRABILITY AND SAFETY.

The D-70A is our answer to various requests from worksites to lift long poles, to drill through tough ground and rock, and to set poles in remote places off the road or on a slope.

AICHI'S multilateral analysis has resulted in, a sturdier structure for improved durability, a more efficient motor, for better boom rotation, a multi operation lever for safety and efficiency, an auger setting mechanism which enables the auger to be installed from the ground, adjustable pole support on the top of the boom and a water tank.

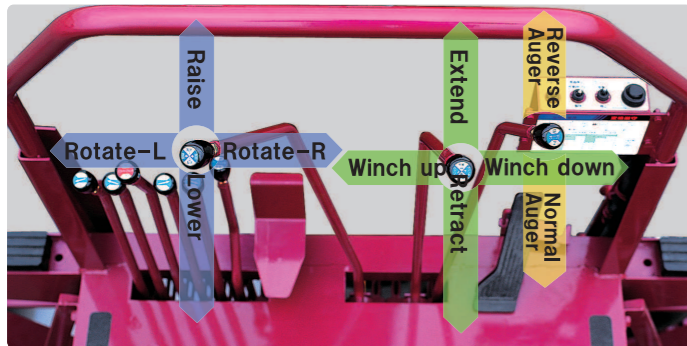

MULTI-OPERATIONAL LEVER (OPTION) (PATENT PENDING)

The operator can handle full operation of the crane or auger using the two multi-operational levers (patent pending) and the foot step. In addition, the rigid booms and efficient rotation motor provide delicate inching.

- Maximum drilling depth 5.2m (17.1ft)
- Auger working radius 4.16–11.4m (13.6–37.4ft)
- Auger torque 725kgf-m (5,240ft-lb)



Auger setting mechanism (from ground)*

This mechanism permits easy setting of the auger.



Water Tank and Electric Pump

A 100 litre (26.4gals) water tank is equipped as a standard accessory. This tank provides a convenient and effective way to compact recently dug earth, and is also useful to clean the auger and bed.

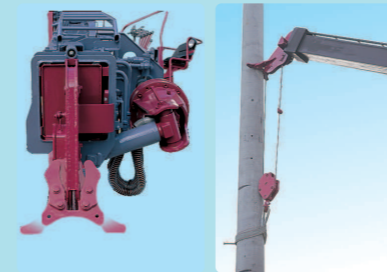

Adjustable pole support

The pole support horns have various settings to suit the wide range of jobs that the machine can be used for. To squeeze into a narrow place such as between the power lines, the horns can be retracted for compactness, and for ordinary jobs the horns can be extended to hold the pole. Hydraulic pole grabs are available as an option.



Parallel hook movement device

During extension and retraction of the boom the parallel hook movement device, maintains a constant distance between the hook and the boom head, without having to operate the winch.



Hook over-wind checking device

The device automatically stops the winch up operation before the winch overwinds preventing damage to the wire rope.



Remote Engine Stop Device (E.S.S)

E.S.S is located at the operators seat as a standard device which allows the operator to start or stop the engine without moving away from the operator's seat. This device helps to minimize the emission of noise and exhaust, and helps to save energy.



Wide and flat bed

The D-70A is equipped with a wide and flat bed for easy cleaning. A large tool box is also installed on the right side.

	Multi-operation Levers	Oil Cooler
	Two levers to operate both auger & crane simultaneously	To check temperature rise of hydraulic oil
STD		
L	○	
C		○
LC	○	○

- Maximum lifting height 14.15m (46.4ft)
- Crane lifting capacity 3.0ton×4.6m (6,600lbs×15.1ft)
- Crane working radius 0.80–11.70m (2.6–38.4ft)

Full Assortment

Three selections are available to suit the needs of worksite.

