

**SELF LOADING MOBILE  
CONCRETE MIXER**

# ARGO 1000



**ARAI CERTIFIED – CAN BE REGISTERED WITH RTO**

- Articulation Angle : 30 Degree on Both Sides
- Gradeability : 21 Degree
- 180 Degree Swivelable Operator Post
- Typical Output : 3 - 4 Cu.m / hr

Self-Loaders | Batching Plants | Pumps

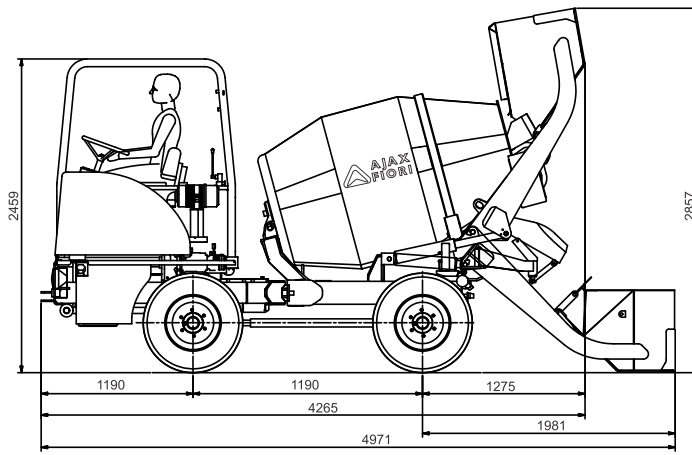
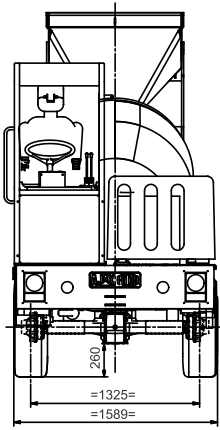

### SELF LOADING



### ARTICULATION



### SWIVELABLE OPERATOR POST



### TIGHT TURNING RADIUS

### WATER BATCHING SYSTEM

### CONCRETE BATCH CONTROLLER

**ENGINE:**  
Mahindra and Mahindra MDI 1895 engine-28.7 kw @ 2600 rpm, Maximum Torque 120 NM @ 1400 – 1600 rpm, 3 cylinders inline BS III CEV Emission Certified.

**CHASSIS:**  
Articulated, High tensile steel welded "C" type construction.

**AXLES:**  
Full floating hypoid type fixed front and rear axle.

**TRANSMISSION:**  
4 wheel drive, with hydrostatic transmission.  
Vehicle speed - 0 to 6 Km/h (Low)  
0 to 11 Km/h (High)

**STEERING**  
Full power hydraulic steering operated through independent gear pump.

**BRAKES**  
Power brake with oil cooled disc type brakes on all 4 wheels. Hand operated parking brake

**WATER SYSTEM**  
230 lpm Self priming pump & flow meter batching from external sources or from 65 L onboard water tank

**ELECTRICAL SYSTEM**  
Battery: 12V, 80 Amp-hr.  
Complete lighting & signaling system as per CMVR standards.

**HYDRAULIC DRUM DRIVE**  
Hydrostatic Drum Drive with high rotation for homogenous mix, fast and complete discharge even on inclines  
Drum volume : 1.7 cu.m  
Concrete output : 1 cu.m  
Maximum Drum rotation: 0 - 18 rpm  
infinitely variable for mixing & discharge

**SELF LOADING SYSTEM:**  
Single joystick controlled hydrostatic cylinders operated loading shovel of 370 L.

**REVERSIBLE OPERATOR POST :**  
180 degree Swivelable operator post for complete visibility during driving. The operator can face loading side during weigh batching and discharge operations.

**CONCRETE BATCH CONTROLLER**  
A system for automation of weighing. This is installed in the operator's cabin allowing easy monitoring of material weights

**SERVICE REFILL CAPACITIES**  
Fuel tank : 34 L Hydraulic tank : 45 L

**WHEEL**  
Tyre : 10.0/75 x 15.3 - 18 PR  
Rim size : 9.0" x 15"

**WEIGHT**  
Net vehicle weight : 2740 kg  
Gross vehicle weight : 5140 kg



### AJAX FIORI ENGINEERING (INDIA) PRIVATE LIMITED

# 253/1, 11th Main, 3rd Phase, Peenya Industrial Area, Bangalore-560058, INDIA  
CIN No : U28920KA1992PTC013306  
T : 91 80 6720 0082, 6720 0083, F: 91 80 6720 0031  
Email : contact@ajax-fiori.com, Website: www.ajax-fiori.com

Specifications are subject to change without prior notice

For Sales Queries : Northern Region : 096500 36628 Eastern Region : 094331 44581  
Southern Region : 098450 58628 Western Region : 099672 63628

Factory: 3, 16 & 17, KIADB Industrial Area, Bashettihalli Doddaballapur - 561 203, P: + 91 80 6720 1135

Courtesy of Machine.Market