

BLADE:
Your choice of Full-U, Semi-U or Straight Blade. Standard blade minimum of 184 inches (4673mm) wide, 76 inches (1930mm) high including full width trash screens. Bolt-on reversible cutting edges and replaceable end bits.

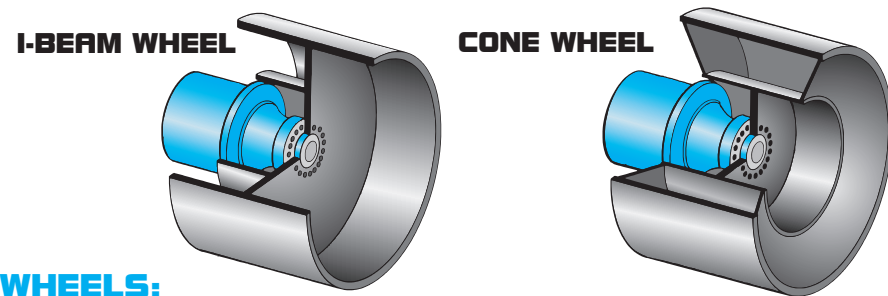

WHEELS:
Standard wheels are 48 inches (1219mm) wide I-beam style with 2 inch (50mm) thick outer drums and 8 inch (203mm) tall MacPactor M-Trax Diamond 1-piece, weld-on style cleats. Drum diameter is 58 inch (1473mm) overall diameter is 74 inch (1879mm). Cleats are arranged to provide effective traction and demolition and to prevent material plugging without the use of cleaner bars. Contact Al-jon for other available wheel options.

8 INCH TALL CLEAT OPTIONS (203mm)



**AL-JON INC. SOLID WASTE DIVISION
WIRE OR CABLE WRAP STRUCTURE
WARRANTY**

Al-jon MFG.LLC, Solid Waste Division, will warranty the following for a period of Five (5) Years or 10,000 Hours, whichever occurs first:

Wheel Inner Drum	Wheel Side Wall (Inner Cone)
Welds Attaching Cones to Drums	Planetary or Planetary Shaft Seals
Axle Structure	

This warranty guarantees repair or entire replacement of any listed component damaged by wire, cable or other foreign debris trapped between the wheels and the frame of the compactor. Exercise of this warranty and its extent by Al-jon MFG. LLC. or its representative shall be at the discretion of Al-jon MFG. LLC, Solid Waste Division. All expenditures made to exercise this warranty are the responsibility of Al-jon MFG. LLC excluding consequential damages, lost production, etc.

This warranty shall remain in effect for the time period indicated above, and shall apply to the original purchaser only.

01-27-2011

AL-JON MFG. **ADVANTAGE** LANDFILL COMPACTOR **525**



KEEPING IT SIMPLE ► BUILDING IT STRONG

AL-JON MFG. LLC SOLID WASTE DIVISION

OTTUMWA, IOWA ► 888-255-6681 ► www.aljon.com



ADVANTAGE 525 SERIES

LANDFILL COMPACTOR

OPERATING WEIGHT:
MIN. - 107,000 lbs.

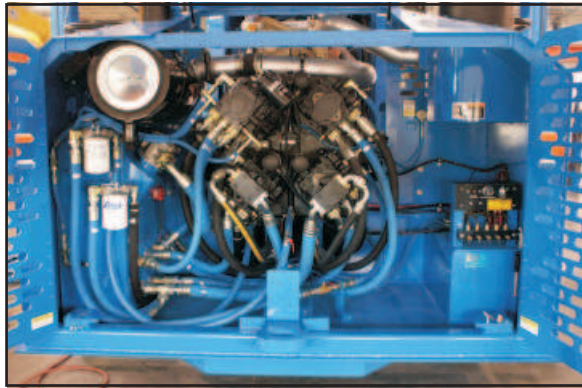

FILTRATION and COOLING:

Hydraulic system features 100 mesh screened inlet filtration, 5 micron return line filtration and independent 10 micron filtration for each individual wheel circuit. Cooling components are oversized all aluminum construction and feature in-line tubes with 6.5 cooling fins per inch for superior performance in dusty landfill conditions. Corrugated and perforated pre-screens pull out for easy maintenance.



DRIVE:

Hydrostatic drive, with each wheel driven by its own independent system, consisting of PC-controlled variable displacement pump, motor and planetary reduction final drive.



SPEED:

4 Speeds Forward,
4 Speeds Reverse.
0 to 5.2 mph
(0 to 8.4 km/hr)



GAUGES:

Illuminated, analog style gauges display engine oil pressure, engine coolant temperature, fuel level, and tachometer.

MC400 ELECTRONIC CONTROL SYSTEM:

Continuously calibrates all four wheels with the angle of the center joint to improve steering, reduce component wear and increase operator comfort. The MC400 monitors all critical components and alerts the operator via digital display and/or alarm and shuts down the machine when potentially damaging conditions exist.

CAB:

Ergonomically-designed, insulated and sound suppressed. ROPS/FOPS certified. Six-way adjustable air ride seat, adjustable head rest and 3 inch wide seat belt. Joystick steering with horn button. Joystick blade control with blade (raise, lower, float), speed selector, and directional controls. Illuminated analog style gauges, MC400 digital display screen and warning indicators. 40,000 BTU front and rear A/C system with directional vents. 30,000 BTU front and rear Heat/Defrost system. Filtered fresh air intake. AM/FM radio/CD, MP3 port, four speaker stereo. Integrated CB antenna. Rear vision camera with full color display. Four exterior West Coast Mirrors. Four front and rear, two side Halogen exterior lights. Front and rear wiper/washer (intermittent front wiper). Two 12V DC accessory. 4 cup holders, 2 coat hooks and Dome light.

CAPACITIES:

Fuel:	205 gallons	(776 liters)
Hydraulic oil, main tank:	70 gallons	(264 liters)
Hydraulic oil, reserve tank:	70 gallons	(264 liters)
Engine coolant:	19 gallons	(71 liters)
Engine lube oil system:		
Cat Engine	9.0 gallons	(34 liters)
John Deere Engine	10.5 gallons	(39 liters)

DIMENSIONS:

Overall length:	30ft 5in	(9271mm)
Overall width at wheels:	14ft 7in	(4445mm)
Overall height at ROPS:	13ft 10in	(4216mm)
Wheelbase:	12ft	(3657mm)
Turning radius (inside):	10ft 6in	(3200mm)
Ground clearance:	28 7/8in.	(733mm)
Articulation: plus/minus	35 degrees	
Oscillation: plus/minus	6 degrees	

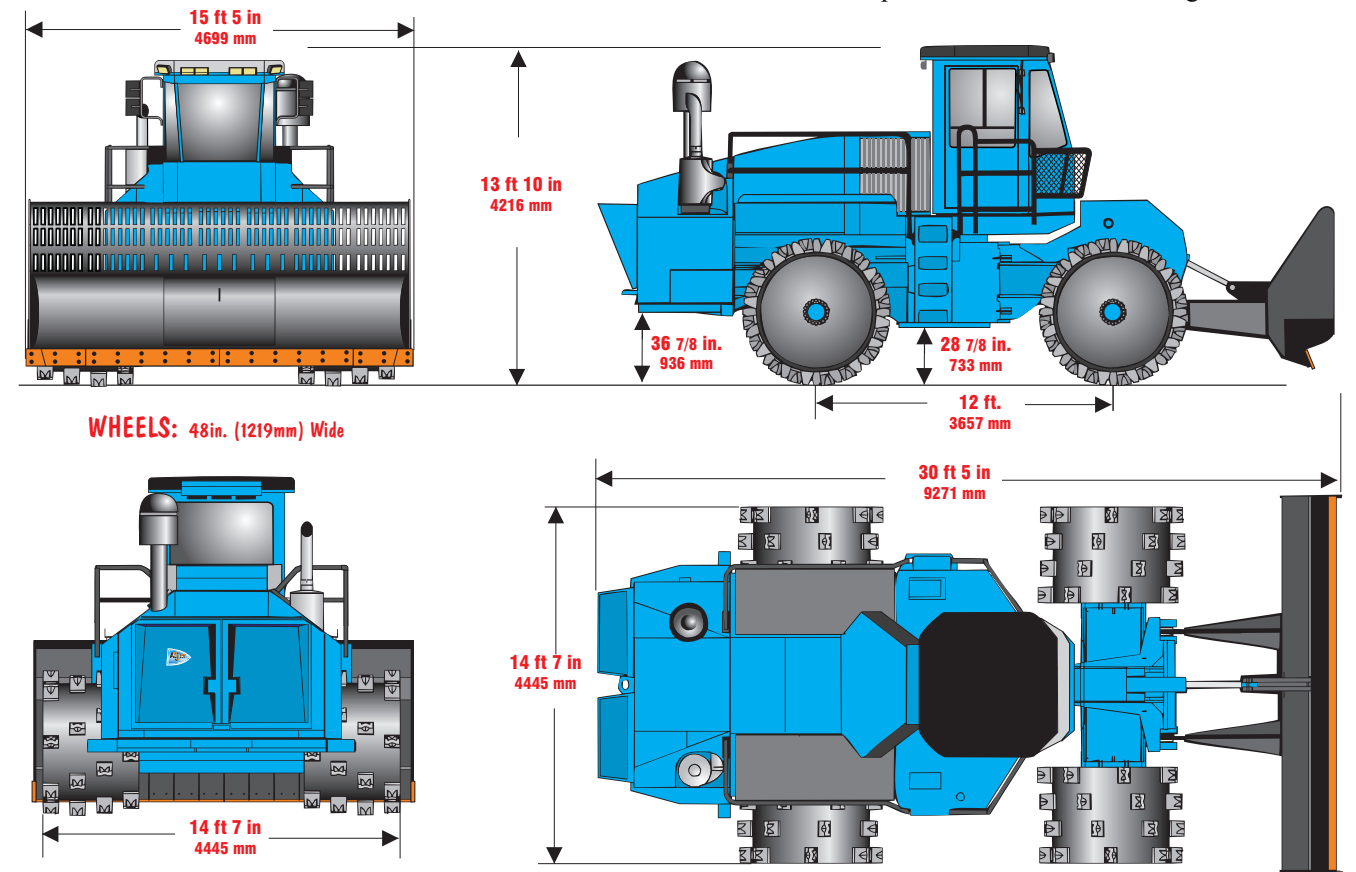

BRAKES:

OSHA-approved, all-wheel hydrodynamic braking. Independent spring-applied, hydraulic-release fail-safe parking/emergency brakes on front wheels.

FRAME:

Extra heavy box beam construction with 1 1/2 inch (38mm) flanges and 1 inch (25mm) thick webs. Center joint with 4 inch (101mm) thick rear tangs and one 2 inch (50mm) and three 1 1/2 inch (38mm) thick front tangs.

ELECTRICAL SYSTEM:

24 volt electrical system with four maintenance free, heavy duty 925CCA batteries. Cat engine has a 95 AMP and John Deere engine has a 140 AMP Alternator.

ENGINE:

Caterpillar® C15 ACERT™: 15.2 liter/540 gross horsepower - OR - John Deere® 6135H PowerTech Plus™: 13.5 liter/550 gross horsepower

These turbo-charged and after-cooled six cylinder diesel engines meet current Tier 3/Stage IIIA emissions regulations. Direct injection fuel system with adjustment-free injection pumps and valves. 1500 watt engine block heater. 24 volt direct electric starting with ether starting aid. Dual, dry-type, two-stage air cleaner. Pressure lubrication with full-flow filtered oil and heat exchange oil cooler. Al-jon hydraulic, auto-reverse cooling fan ("ARC") is standard.

OPTIONS:

Contact Al-jon for a list of available options.