



Altec L42M/L45M Overcenter Aerial Device



- Working Height to 50 ft (15.2 m)
- Side Reach to 37 ft (11.3 m)
- 1,500 lbs Maximum Jib Capacity



- 400 lbs Platform Capacity
- Compact 84" CA and Low Travel Height
- Altec ISO-Grip® System



STANDARD FEATURES

- Altec Single Handle ISO-Grip® System
- Overcenter Aerial Device with Altec Patented Walking Link
- Mechanical Platform Leveling System
- Full Pressure, Open Center Hydraulic System
- Material Handling System, 1,500 lbs Maximum
- Manual Extension, Hydraulic Tilting Jib
- 400 lbs Platform Capacity
- Continuous Rotation
- 24 x 30 x 42 in Platform with 90° Hydraulic Rotator
- Diagnostic Pressure Test Quick Disconnect Couplings
- Hydraulic Tool Circuit at Boom Tip
- Category C 46 kV with Lower Boom Insulator
- Automatic Throttle System
- Hydraulic Platform Tilt
- Outrigger Motion Alarm
- Outrigger/Boom Interlock System

GENERAL SPECIFICATIONS

	L42M		L45M	
Ground to Bottom of Platform*	42.6 ft	13.0 m	45.0 ft	13.7 m
Working Height*	47.6 ft	14.5 m	50.0 ft	15.2 m
Maximum Reach –				
Upper Boom Overcenter	34.6 ft	10.5 m	36.9 ft	11.3 m
Upper Boom Non-overcenter	35.2 ft	10.7 m	37.0 ft	11.3 m
Stowed Travel Height*	11.1 ft	3.4 m	11.1 ft	3.4 m
Platform Capacity	400 lbs	181 kg	400 lbs	181 kg
Material Handling Capacity –				
Minimum	500 lbs	227 kg	400 lbs	181.4 kg
Maximum	1500 lbs	681 kg	1350 lbs	612.4 kg
Isolation Gap –				
Upper Boom	141.9 in	3604 mm	155.9 in	3960 mm
Lower Boom	15.0 in	381 mm	15.0 in	381 mm
Upper Boom Articulation	0° to 205°		0° to 205°	
Lower Boom Articulation	0° to 125°		0° to 125°	
Unit Rotation	Continuous		Continuous	
Platform Rotation	90°		90°	

*Based on 40 in (1016 mm) Chassis Frame Height



125 degrees of lower boom articulation allows operator to access bins and the ground from the non-overcenter position.

OPTIONS

- Hydraulically Extendible Jib
- Low Stow Upper Boom
- Insulated, Category B, 46 kV
- Engine Start/Stop
- Remote Secondary Stowage System
- Multiple Platform Step Locations
- Additional Tool Circuit at Boom Tip
- Tool Circuit at Tailshelf
- Manual Throttle Control
- Lower Boom Lifting Eye

RECOMMENDED FEATURES

- Fall Protection System
- Platform Liner
- Wheel Chocks
- Outrigger Pads

REACH DIAGRAM

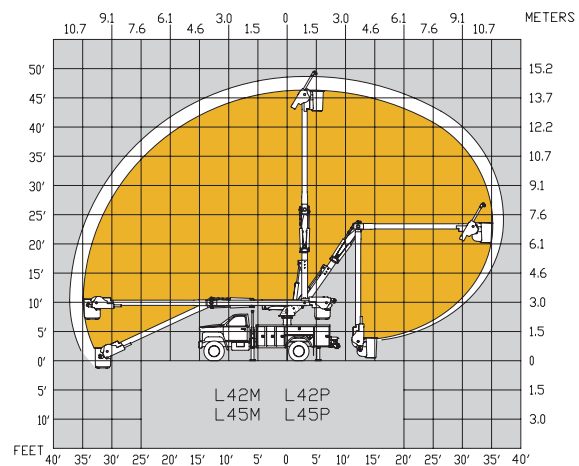

Altec Aerial Devices meet or exceed all applicable ANSI Standards as of the date of manufacture. Altec reserves the right to improve models and change specifications without notice or obligation.



Select the normal upper boom stow position for open bed space or the low stow position to simplify platform access.

Altec Sales and Service