

# ASPEN A-62

Bridge Inspection Unit

## New Technologies Lead the Industry

**Design.....**Through extensive research utilizing customer input, FEA engineering and repetitive motion testing, the Aspen A-62 was designed from the ground up resulting in greater versatility, simplicity and reliability under all types of conditions. This model has been extended to access areas over, around and under some of your widest bridges to provide you with the pinnacle of “no-compromise” performance and efficiency.

**Maneuverability.....**Two rotating turntables plus multiple articulating and telescoping booms allow the 40”x 60” rotating platform to deploy off of either side of the truck to access all of your structures. The Aspen A-62 is truly in a league of its own.

**Stabilization.....**Outriggers are not required and all counterweights stay within the width of the truck body. The redesigned sliding counterweight is installed under the truck bed and operates to either side while the Aspen A-62 is deployed to the opposite side. In the transport mode, the counterweight stays in the center of the truck for improved road handling. A torsion-box subframe and hydraulic axle locks unitize the chassis and truck axles, allowing the vehicle to travel while the unit is fully deployed.



### Reliable

#### Adjustable Turntable



Turntable no. 2 comes equipped with an automatic leveling system, providing smooth platform movement. In addition, the operator can make manual adjustments of +/- 5 degrees to compensate for the slope of the bridge. With the elimination of the leveling arms, the Aspen A-62 has more vertical clearance to get over high fences.

### Innovative

#### Telescoping & Rotating Platform



- 180 degree rotating platform
- Telescoping 4th boom
- Over 13' vertical reach

### Durable

#### Advanced Control System



As the most advanced microprocessor control system available, the “Plus 1” Graphical Terminal Interface includes a color display depicting unit operation and individual function performance while monitoring the unit’s parameters, hydraulics and enabling simple troubleshooting. Wireless controls are included at both operator stations.

# Platform Features

## Telescoping 4th boom

The Aspen A-62 has the capability of providing inspectors with over 13' (4m) of vertical reach. This fully hydraulic feature will enable you to get up and behind your deepest girders for a close-up inspection.

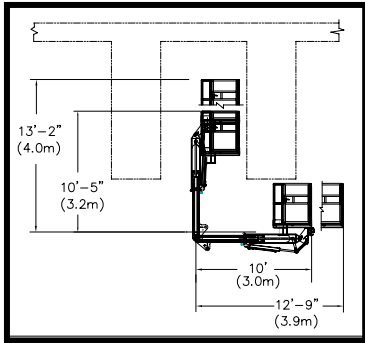

## Rotating Platform

The added flexibility of a 180 degree rotating platform makes maneuvering into working positions easy, increasing productivity and efficiency.

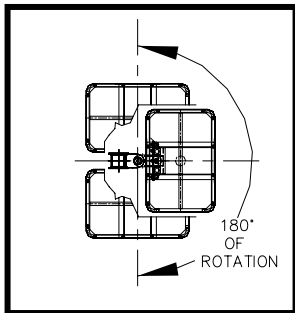

Aspen Aerials, Inc.  
4303 West 1st Street  
Duluth, MN 55807

Phone: 218-624-1111  
Toll Free: 800-888-2773  
Fax: 218-624-1714  
Web site: [www.aspenaerials.com](http://www.aspenaerials.com)



# Specifications

## Flight Diagram

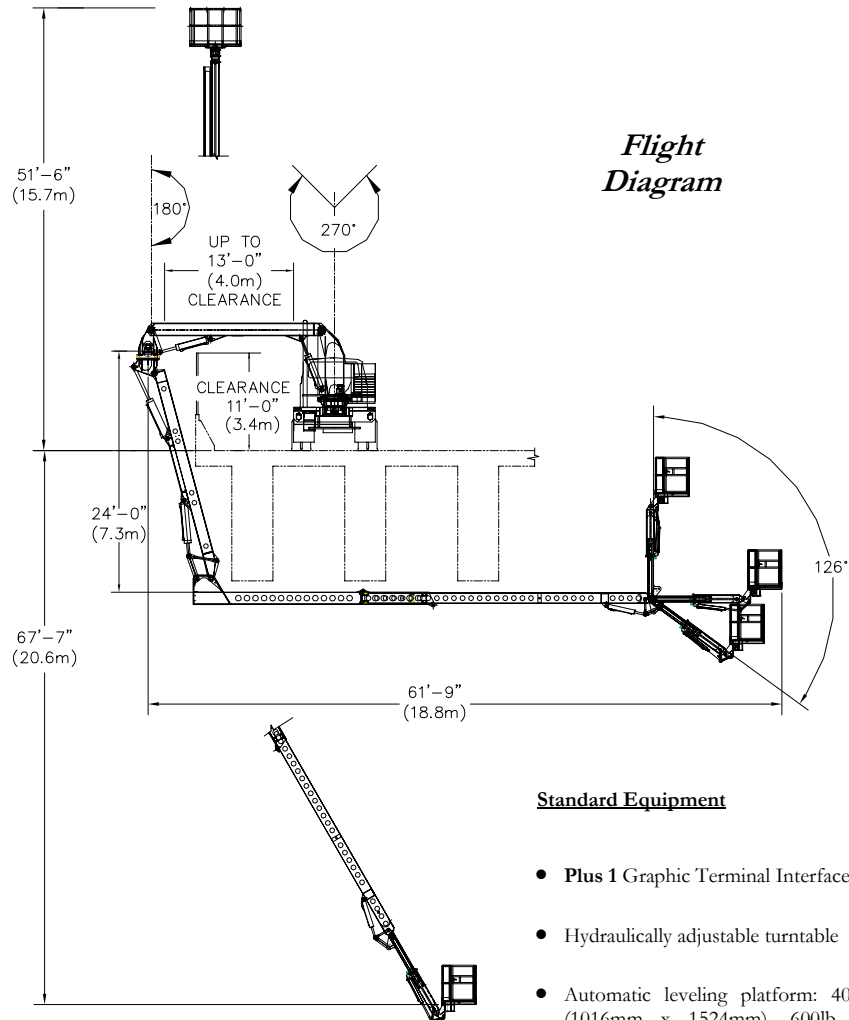

## Standard Equipment

- Plus 1 Graphic Terminal Interface
- Hydraulically adjustable turntable
- Automatic leveling platform: 40" x 60" (1016mm x 1524mm), 600lb. (272kg) capacity w/access gate
- 2 sets of controls: one set in the platform and one set at the pedestal
- 4 articulating booms (3rd & 4th booms telescope); 2 rotating turrets, rotating platform
- Stability interlocks with monitoring system
- Two power systems: power take-off from the truck's transmission and a back-up diesel power unit
- 12-volt intercom system between platform,

Horizontal Underbridge Reach	61'-9" / 18.8m
Vertical Reach Down	67'-7" / 20.6m
Vertical Reach Up	51'-6" / 15.7m
Boom no. 1 movement	+30 to -35 degrees
Boom no. 2 movement	+0 to -105 degrees
Boom no. 3 movement	+90 to -60 degrees
Boom no. 4 movement	+90 to -36 degrees
Space Required on Bridge	102" / 2.5m
Basket Capacity	600 lbs. / 272 kg.
Basket Size	40" x 60" x 42" 1010mm x 1520mm
Overall Length	40' / 12.2m *
Overall Height	13'-3" / 4.0m *

\* May vary depending on chassis

## Available Options:

- Air Compressor and air line in platform
- Generator with electrical outlet in platform
- Platform Heaters & Floodlights
- Remote Controls



Various chassis configurations available