

EFFECTIVE SERIAL NO. _____

OWNERS MANUAL

5005EH

REVISION 2/2000

PART NO. 999955

SERIAL NO. _____

AUTO CRANE COMPANY

PO BOX 580697, TULSA, OK 74158-0697

4707 N. MINGO ROAD, TULSA, OK 74117-5904

PHONE (918) 836-0463

SALES FAX (918) 438-6688 SERVICE FAX (918) 834-5979

<http://www.autocrane.com>

!! DISTRIBUTORS !!

**PROTECT YOUR CUSTOMER'S WARRANTY!
SUBMIT DELIVERY REPORT WITHIN 15 DAYS.**

Mail to: Auto Crane Company
P.O. Box 580697
Tulsa, OK 74158-0697

Or Fax to: 918/834-5979

Protect your customers warranty - Submit within 15 days from delivery date.



AUTO CRANE COMPANY

**DISTRIBUTOR
DELIVERY REPORT**

DISTRIBUTOR _____		OWNER _____	
ADDRESS _____		CITY/STATE _____	
CITY/STATE/ZIP _____		BUSINESS _____	
MODEL #	SERIAL #	DATE DELIVERED	UNIT DESTINATION

IMPORTANT: ATTACH SIGNED COPY OF CUSTOMER INVOICE / DELIVERY RECEIPT

AC-109 REPORT AUTHORIZED BY: _____

*** REGISTER ONE UNIT ONLY PER CARD ***

WARNINGS - READ THIS PAGE!

WARNING! Federal law (49 cfr part 571) requires that the Final Stage Manufacturer of a vehicle certify that the vehicle complies with all applicable federal regulations. Any modifications performed on the vehicle prior to the final stage are also considered intermediate stage manufacturing and must be certified as to compliance. The installer of this crane and body is considered one of the manufacturers of the vehicle. As such a manufacturer, the installer is responsible for compliance with all applicable federal and state regulations, and is required to certify that the vehicle is in compliance.

WARNING! It is the further responsibility of the installer to comply with the OSHA Truck Crane Stability Requirements as specified by 29 CFR part 1910.180 (C) (1).

WARNING! NEVER OPERATE THE CRANE NEAR ELECTRICAL POWER LINES! Death or serious injury will result from boom, line, or load contacting electric lines. Do not use crane within 10 feet (3.05m) of electric power lines carrying up to 50,000 volts. One foot additional clearance is required for every additional 30,000 volts or less.

WARNING! NEVER

- v **EXCEED** load chart capacities (centerline of rotation to hoist hook).
- v un-reel last 5 wraps of cable from drum!
- v wrap cable around load!
- v attempt to lift or drag a load from the side! The boom can fail far below its rated capacity.
- v weld, modify, or use unauthorized components on any Auto Crane unit! This will void any warranty or liability. Also failure of the crane may result.
- v place a chain link on the tip of the hook and try to lift a load!
- v use a sling bar or anything larger than the hook throat that could prevent the hook latch from closing, thus negating the safety feature!
- v hold on any pendant Select Switch that will cause unsafe operating conditions!

WARNING! In using a hook with latch, **ALWAYS** make sure that the hook throat is closed before lifting a load! Proper attention and common sense applied to the use of the hoist hook and various slings will prevent possible damage to material being hoisted and may prevent injury to personnel.

WARNING! Failure to correctly plumb and wire crane can cause inadvertent operation and damage to crane and/or personnel!

WARNING! Auto Crane Company remote controlled cranes are not designed or intended to be used for any applications involving the lifting or moving of personnel.

WARNING! ALWAYS operate the crane in compliance with the load capacity chart. **Do not use** the overload shutdown device to determine maximum rated loads, if your crane is equipped with this type of device.

5005EH SERIES - OWNER'S MANUAL
TABLE OF CONTENTS

	Page
INTRODUCTION	1-1.0.0
OPERATING PRACTICES & WARNINGS	1-2.0.0
OPERATION OF UNIT / OUTRIGGERS	1-3.0.0
QUALIFICATIONS FOR OPERATORS	1-2.1.0
INSPECTION, TESTING & MAINTENANCE	1-3.1.0
SAFETY DECAL SECTION	5-1.1.0
GENERAL DIMENSIONS	6-1.0.0
INSTALLATION	7-1.0.0
OUTRIGGERS (STABILIZER ASSEMBLY)	7-3.0.0
LUBRICATION & MAINTENANCE SCHEDULE	8-1.0.0
LIFE OF WIRELINE	9-1.0.0
GENERAL ASSEMBLY (PEDESTAL)	10-1.0.0
BOOM ASSEMBLY	10-2.0.0
2-BLOCK ASSEMBLY	10-4.0.0
HOIST ACTUATOR	10-5.0.0
AUTOMATIC SAFETY BRAKE	10-6.1.0
SOLENOID ASSEMBLY for HOIST ACTUATOR	10-7.0.0
ROTATION GEAR BOX	10-8.0.0
COVER INSTALLATION for POWER UNIT	10-9.0.0
HYDRAULIC SECTION	11-1.0.0
ELECTRICAL SECTION	12-1.1.1
TRAVELING BLOCK	13-1.0.0
LOAD CHART	14-1.0.0
WARRANTY	LAST PAGE

INTRODUCTION

5005EH SERIES

Auto Crane products are designed to provide many years of safe, trouble-free, dependable service when properly used and maintained.

To assist you in obtaining the best service from your crane and to avoid untimely crane and/or vehicle failure, this manual provides the following operating and service instructions. It is **specifically recommended** that all operating and service personnel consider this manual as mandatory material for reading and study before operating or servicing Auto Crane products. It is **highly recommended** that crane owners, equipment managers and supervisors also read this manual.

Auto Crane has incorporated several safety features in the 5005EH series cranes for your protection. The choice of materials and the design of the electrical system minimizes weight and lengthens durability. The hydraulic components meet or exceed a **3.5:1 safety factor**. Holding valves prevent the load from dropping if a hose should fail. The reservoir has a **40m air filter** in the filler cap. The pump has a **100 mesh strainer** in the suction line.

For your convenience the overall dimensions of the 5005EH series crane are in the General Dimension Section. Maximum turning radius at both the hoist motor and the rotation motor are also on that drawing.

Remember, the crane adds weight to the vehicle. Adding weight may change the driving and riding characteristics of the vehicle unless the appropriate overload spring(s) are installed on the truck. The payload of the vehicle is reduced by the weight of the crane. The operator should exercise care when loading the vehicle. Distributing the payload on the vehicle evenly will greatly improve the driving and riding characteristics of the vehicle. **A minimum G.V.W. of 10,500 lb with two rear jacklegs (or outriggers) is recommended for mounting the 5005EH series cranes.**

The 5005EH series cranes are attached directly to your 12 volt truck electrical system. The power cable and retaining clips are included with the crane. A typical power cable mounting and hookup is shown in the installation section. The performance of your new crane depends on the truck electrical system. The use of maintenance free batteries is **NOT** recommended for use with any Auto Crane product. The recommended alternator and battery that will give the longest life with the most useful duty cycle is a 60 amp alternator with a 120 minute reserve capacity, deep cycle battery. These specifications should be considered minimum.

Auto Crane Company issues a limited warranty certificate with each unit sold. See last page for warranty policy.

It has always been Auto Crane Company policy to handle all warranty claims we receive as promptly as possible. If a warranty claim involves discrepant material or workmanship, Auto Crane will take immediate corrective action. It is understandable that Auto Crane Company cannot assume responsibility of liability when it is obvious that our products have been abused, misused, overloaded or otherwise damaged by inexperienced persons trying to operate the equipment without reading the manual.

Auto Crane will not assume responsibility or liability for any modifications or changes made to unit, or installation of component parts done without authorization.

Auto Crane maintains a strong distributor network and a knowledgeable Customer Service Department. In most cases, an equipment problem is solved via phone conversation with our customer service department. The customer service department also has the ability to bring a local distributor, a regional sales manager, or a factory serviceman into the solution of an equipment problem. If, through no fault of Auto Crane Company, it is necessary to send an experienced factory serviceman on a field service call, the rates stated in the Auto Crane Distributor's Flat Rate Manual will apply.

Auto Crane Company's extensive Research and Development Program allow our customers to use the best equipment on the market. Our Engineering Staff and our knowledgeable sales people, are always available to our customers in solving crane and winch-type application problems. When in doubt, call the Auto Crane factory.

DISTRIBUTOR ASSISTANCE:

Should you require any assistance not given in this manual, we recommend that you consult your nearest Auto Crane Distributor. Our distributors sell authorized parts and have service departments that can solve almost any needed repair.

NOTE: THIS MANUAL SHOULD REMAIN WITH THE CRANE AT ALL TIMES.

This manual does not cover all maintenance, operating, or repair instructions pertinent to all possible situations. If you require additional information, please contact the **Auto Crane Company** at the following telephone number: **(918) 438-2760**. The information contained in the manual is in effect at the time of this printing. Auto Crane Company reserves the right to update this material without notice or obligation.

IMPORTANT OPERATING PRACTICES & WARNINGS

1. Make certain the vehicle meets minimum chassis requirements. (These requirements do not guarantee unit stability)
2. Make certain the crane is installed per factory specifications. Contact your local Distributor or the Auto Crane factory if any questions arise.
3. Keep the vehicle in as level a position as possible while loading or unloading.
4. **ALWAYS** set the vehicle emergency brake before beginning crane operations.
5. **ALWAYS** use outriggers from vehicle to the ground during crane operation. Make sure they are firmly positioned on solid footings.
6. All load ratings are based on crane capacity, **NOT** truck/crane stability.
7. Keep objects and personnel clear of crane path during operation.
8. Keep hoist cable pulled tight at all times.
9. **REMEMBER**, in lifting a heavy load, the weight can create enough tipping momentum to overturn the vehicle.
10. **ALWAYS** keep load as close to ground as possible.
11. Oil gears as required.
12. Periodic adjustment of hoist worm brake may be required (see automatic safety brake drawing in this manual).
13. Hydraulic hoses need to be inspected frequently for signs of deterioration, and be replaced as required.
14. The hoist hook is an important item that an operator should consider and use properly. It should be checked on a daily basis for distortion or cracks.
15. **ALWAYS** store outriggers before road travel.
16. **WARNING! NEVER OPERATE THE CRANE NEAR ELECTRICAL POWER LINES!** Death or serious injury will result from boom, line, or load contacting electric lines. Do not use crane within 10 feet (3.05m) of electric power lines carrying up to 50,000 volts. One foot additional clearance is required for every additional 30,000 volts or less.
17. **WARNING! NEVER EXCEED** load chart capacities (centerline of rotation to hoist hook).
18. **WARNING! NEVER** unreel last 5 wraps of cable from drum!
19. **WARNING! NEVER** wrap cable around load!
20. **WARNING! NEVER** attempt to lift or drag a load from the side! The boom can fail far below its rated capacity.
21. **WARNING! NEVER** weld, modify, or use unauthorized components on any Auto Crane unit! This will void any warranty or liability. Also failure of the crane may result.
22. **WARNING! NEVER** place a chain link on the tip of the hook and try to lift a load!
23. **WARNING! NEVER** use a sling bar or anything larger than the hook throat that could prevent the hook latch from closing, thus negating the safety feature!
24. **WARNING!** In using a hook with latch, **ALWAYS** insure that the hook throat is closed before lifting a load! Proper attention and common sense applied to the use of the hoist hook and various slings will prevent possible damage to material being hoisted and may prevent injury to personnel.
25. **WARNING! NEVER** hold any pendant Select Switch on that will cause unsafe operating conditions!

WARNING!

Auto Crane Company remote controlled, stiff boom cranes are not designed or intended to be used for any applications involving the lifting or moving of personnel.

--- IMPORTANT --- OPERATION OF UNIT

26. Make sure this manual has been thoroughly read by all crane operating personnel and supervisors.
27. A routine inspection of the crane should be mandatory before each operating day. Any defects should be corrected immediately.
28. At a job site the vehicle should be positioned so that the crane can adequately reach the load within the rated capacity (centerline of rotation to hoist hook).
29. Keep the vehicle as level as possible during operation.
30. For electric cranes, **engage emergency brake** and leave ignition on with transmission in neutral (or in park for automatic transmissions). Activate any crane power switches. For Auto Crane units requiring battery and hydraulic operation, **engage emergency brake**, place gear selector in neutral, press clutch, activate PTO, release clutch and after hydraulic fluid is warm, set throttle control to proper engine speed.
31. Always use outriggers from the truck to the ground. Be sure these are firm and adequately positioned. When rotating, **keep load as low to the ground as possible**.
32. Remove pendant control from cab or storage area. On smaller units, plug pendant into receptacle on crane. On larger units, remove pendant control from guard and unwrap cable from boom. Do not operate crane until cable is unwound completely. On all cranes, detach hook from dead man. Crane is now ready for operation.
33. Always boom up before rotating so the boom will clear the required boom support.
34. When extending the boom, always maintain clearance between the boom crown and the traveling block or hoist hook.
35. Always observe safe and practical operation to avoid possible accidents. Refer to Safety Tips and Precautions.
36. After completing lifting operations, return the boom to stowed position on the boom support. Avoid unneeded pressure on the boom support.
37. Store pendant control on proper location (in cab or on crane).
38. Return outriggers to stowed position. Make sure they are pinned in place or jacklegs are returned to compartment.
39. Check work area for any tools or equipment not stored.
40. Release throttle control, depress clutch and disengage PTO. Deactivate any crane power switches.
41. Report any unusual occurrence during crane operation that may indicate required maintenance or repair.
42. **NEVER** use two cranes to support a load too large for either crane.
43. Spray all electrical equipment with special corrosion resistant coating. This eliminates rust or corrosion due to melting and freezing action of condensation.

OPERATION OF OUTRIGGERS

For hydraulic outriggers:

1. Shift crane/outrigger control valve to "outrigger" position.
2. While operating the outrigger control valves (located on the outrigger cylinders) simultaneously operate the boom-up control switch. This will allow the hydraulic system to build pressure.
3. After outriggers are positioned, return crane/outrigger selector to "crane" position.
4. Crane is now ready to operate.

For manual outriggers:

1. Pull lock pins to release jack leg or drop down outrigger and move to outermost lock position.
2. Make sure lock pins are reinstalled properly.
3. Lower outrigger pad to firm ground and adjust foot to take out slack.
4. Crane is now ready to operate.

QUALIFICATIONS FOR AND CONDUCT OF OPERATORS AND OPERATING PRACTICES

OPERATORS

- 1 Crane operation shall be limited to personnel with the following minimum qualifications:**
 - A. designated persons
 - B. trainees under the direct supervision of a designated person
 - C. maintenance and test personnel (when it is necessary in the performance of their duties)
 - D. inspectors (crane).
- 2 No one other than the personnel specified above shall enter the operating area of a crane with the exception of persons such as oilers, supervisors, and those specified persons authorized by supervisors whose duties require them to do so and then only in the performance of their duties and with the knowledge of the operator or other persons.**

QUALIFICATIONS FOR OPERATORS

- 3 Operators shall be required by the employer to pass a practical operating examination. Qualifications shall be limited to the specific type of equipment for which examined.**
- 4 Operators and operator trainees shall meet the following physical qualifications:**
 - A. Vision of at least 20/30 Snellen in one eye and 20/50 in the other, with or without corrective lenses.
 - B. Ability to distinguish colors, regardless of position, if colors differentiation is required for operation.
 - C. Adequate hearing with or without hearing aid for the specific operation.
- 5 Evidence of physical defects or emotional instability which render a hazard to operator or others, which in the opinion of the examiner could interfere with the operator's performance may be sufficient cause for disqualification. In such cases, specialized clinical or medical judgment and tests may be required.**
- 6 Evidence that the operator is subject to seizures or loss of physical control shall be sufficient reason for disqualification. Specialized medical tests may be required to determine these conditions.**

- 7 Operators and operator trainees should have normal depth perception, coordination, and no tendencies to dizziness or similar undesirable characteristics.**
- 8 In addition to the above listed requirements, the operator shall:**
 - A. Demonstrate the ability to comprehend and interpret all labels, operator's manuals, safety codes and other information pertinent to correct crane operations.
 - B. Possess knowledge of emergency procedures and implementation of same.
 - C. Demonstrate to the employer the ability to operate the specific type of equipment.
 - D. Be familiar with the applicable safety regulations.
 - E. Understand responsibility for maintenance requirements of crane.
 - F. Be thoroughly familiar with the crane and its control functions.
 - G. Understand the operating procedures as outlined by the manufacturer.

CONDUCT OF OPERATORS

- 9 The operator shall not engage in any practice which will divert his attention while actually operating the crane.**
- 10 Each operator shall be responsible for those operations under the operator's direct control. Whenever there is any doubt as to safety, the operator shall consult with the supervisor before handling the loads.**
- 11 The operator should not leave a suspended load unattended unless specific precautions have been instituted and are in place.**
- 12 If there is a warning sign on the switch or engine starting controls, the operator shall not close the switch or start the engine until the warning sign has been removed by the appointed person.**
- 13 Before closing the switch or starting the engine, the operator shall see that all controls are in the "OFF" or neutral position and all personnel are in the clear.**
- 14 If power fails during operation, the operator shall:**
 - A. move power controls to the "OFF" or neutral position.

QUALIFICATIONS FOR AND CONDUCT OF OPERATORS AND OPERATING PRACTICES

B. land the suspended load and boom, if practical.

15 The operator shall be familiar with the equipment and its proper care. If adjustments or repairs are necessary, the operator shall report the same promptly to the appointed person, and shall also notify the next operator.

16 All controls shall be tested by the operator at the start of each shift. If any controls do not operate properly, they shall be adjusted or repaired before operations are begun.

17 Stabilizers shall be visible to the operator while extending or setting unless operator is assisted by a signal person.

OPERATING PRACTICES

HANDLING THE LOAD

18 Size of load

- A. No crane shall be loaded beyond the rated load except for test purposes.
- B. The load to be lifted is to be within the rated load of the crane and its existing configuration.
- C. When loads which are not accurately known are to be lifted, the person responsible for the job shall ascertain that the weight of the load does not exceed the crane rated load at the radius at which the load is to be lifted.

19 Attaching the load

- A. The load shall be attached to the hook by means of slings or other devices of sufficient capacity.
- B. Hoist rope shall not be wrapped around the load.

20 Moving the load

- A. The operator shall determine that:
- B. The crane is level and, where necessary, the vehicle/carrier is blocked properly.
- C. The load is well secured and balanced in the sling or lifting device before it is lifted more than a few inches.
- D. Means are provided to hold the vehicle stationary while operating the crane.
- E. Before starting to lift, the hook shall be brought over the load in such a manner as to minimize swinging.

F. During lifting care shall be taken that:

- 1. **there is no sudden acceleration or deceleration of the moving load.**
- 2. **load, boom or other parts of the crane do not contact any obstruction.**

G. Cranes shall not be used for dragging loads sideways.

H. This standard recognizes that articulating boom cranes are designed and intended for handling materials. They do not meet personnel lift or elevator requirements. Therefore, no lifting, lowering, swinging or traveling shall be done while a person is on the hook or load. Hook attached suspended work platforms (baskets) shall not be used with cranes covered by this standard. Work platforms attached to the boom must be approved by crane manufacturer.

I. The operator should avoid carrying loads over people.

J. When the crane is so equipped, the stabilizers shall be fully extended and set. Blocking under stabilizers shall meet the requirements as follows:

- 1. **strong enough to prevent crushing.**
- 2. **of such thickness, width and length as to completely support the stabilizer pad.**

K. Firm footing under all tires, or individual stabilizer pads should be level. Where such a footing is not otherwise supplied, it should be provided by timbers, cribbing, or other structural members to distribute the load so as to not exceed allowable bearing capacity or the underlying material.

L. In transit, the boom shall be carried in stowed position.

M. When rotating the crane, sudden starts and stops shall be avoided. rotational speed shall be such that the load does not swing out beyond the radius at which it can be controlled.

N. The crane shall not be transported with a load on the hook unless recommended by the manufacturer.

O. No person should be permitted to stand or pass under a suspended load.

21 Stowing procedure. Follow the manufacturer's procedure and sequence when stowing and un-stowing the crane.

QUALIFICATIONS FOR AND CONDUCT OF OPERATORS AND OPERATING PRACTICES

MISCELLANEOUS

OPERATING NEAR ELECTRICAL POWER LINES

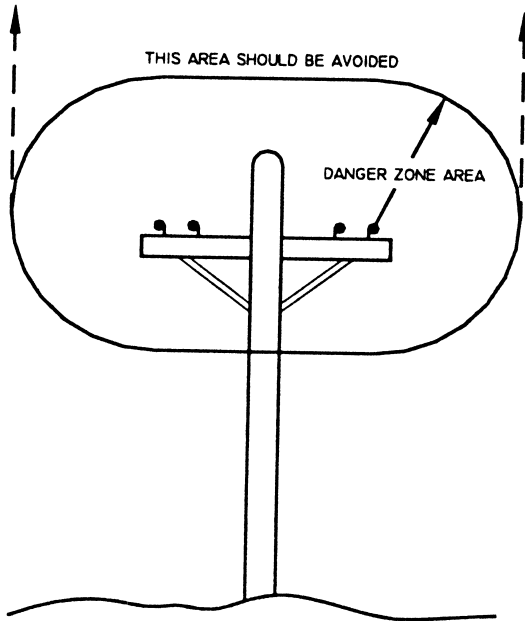

22 Cranes shall be operated so that no part of the crane or load enters into the danger zone shown above.

EXCEPTIONS

- A. The danger zone may be entered after confirmation by an appointed person that the electrical distribution and transmission lines have been de-energized and visibly grounded at the point of work; or
- B. The danger zone may be entered if insulating barriers (not a part of nor an attachment to the crane) have been erected to prevent physical contact with the lines.

23 For lines rated 50 kV or below, minimum clearance between the lines and any part of the crane or load (including handling appendages) shall be 10 ft. (3m). For higher voltages, see Table 1.

24 Caution shall be exercised when working near overhead lines, because they can move horizontally or vertically due to wind, moving the danger zone to new positions.

25 In transit with no load and boom lowered the clearance shall be specified in Table 1.

26 A qualified signalperson shall be assigned to observe the clearance and give warning before approaching the above limits.

- A. Any overhead wire shall be considered to be an energized line unless and until the person owning such line or the electrical utility authorities verify that it is not an energized line.
- B. Exceptions to this procedure, if approved by the administrative or regulatory authority if the alternate procedure provides equivalent protection and set forth in writing.
- C. Durable signs shall be installed at the operator's station and on the outside of the crane, warning that electrocution or serious bodily injury may occur unless a minimum clearance of 10 ft. (3.0m) between the crane or the load being handled and energized power lines. Greater clearances are required because of higher voltage as stated above. These signs shall be revised but not removed when local jurisdiction requires greater clearances.

TABLE 1

normal voltage, kV (phase to phase)		minimum required clearance	
		ft	(m)
<u>when operating near high voltage power lines</u>			
over	to 50	10	(3.05)
over	50 to 200	15	(4.6)
over	200 to 350	20	(6.1)
over	350 to 500	25	(7.62)
over	500 to 750	35	(10.67)
over	750 to 1000	45	(13.72)
<u>while in transit with no load and boom lowered</u>			
over	to 0.75	4	(1.22)
over	0.75 to 50	6	(1.83)
over	50 to 345	10	(3.83)
over	345 to 750	16	(4.87)
over	750 to 1000	20	(6.1)

INSPECTION, TESTING AND MAINTENANCE

GENERAL

INSPECTION CLASSIFICATION

27 Initial inspection. Prior to initial use, all new, altered, modified or extensively repaired cranes shall be inspected by a designated person to insure compliance with provisions of this standard.

28 Regular inspection. Inspection procedure for cranes in regular service is divided into two general classifications based upon the intervals at which inspection should be performed. The intervals in turn are dependent upon the nature of the components of the crane and the degree of their exposure to wear, deterioration, or malfunction. The two general classifications are herein designated as "frequent" and "periodic" with respective intervals between inspections as defined below.

- A. frequent inspection - daily to monthly intervals
- B. periodic inspection - one to twelve intervals, or as specifically recommended by the manufacturer

FREQUENT INSPECTION

29 Inspection shall be performed by designated personnel.

- A. control mechanisms for maladjustment interfering with proper operation - daily, when used
- B. control mechanisms for excessive wear of components and contamination by lubricants or other foreign matter
- C. safety devices for malfunction
- D. all hydraulic hoses, particularly those which flex in normal operation of crane functions, should be visually inspected once every working day, when used
- E. hooks and latches for deformation, chemical damage, cracks, and wear. Refer to ANSI/ASME B30.10
- F. rope reeving for compliance with crane manufacturer's specifications, if optional winch is used

G. electrical apparatus for malfunctioning, signs of excessive deterioration, dirt and moisture accumulation

H. hydraulic system for proper oil level and leaks daily

I. tires for recommended inflation pressure, cuts and loose wheel nuts

J. connecting pins and locking device for wear and damage

PERIODIC INSPECTION

30 Deformed, cracked or corroded members in the crane structure and carrier.

31 Loose bolts, particularly mounting bolts.

32 Cracked or worn sheaves and drums.

33 Worn, cracked, or distorted parts such as pins, bearings, shafts, gears, rollers and devices.

34 Excessive wear on brake and clutch system parts and lining.

35 Crane hooks inspected for cracks.

36 Travel steering, braking, and locking devices, for malfunction.

37 Excessively worn or damaged tires.

38 Hydraulic and pneumatic hose, fittings, and tubing inspection.

A. evidence of leakage at the surface of the flexible hose or its junction with metal and coupling

B. blistering, or abnormal deformation to the outer covering of the hydraulic or pneumatic hose

C. leakage at threaded or clamped joints that cannot be eliminated by normal tightening or recommended procedures

D. evidence or excessive abrasion or scrubbing on the outer surface of a hose, rigid tube, or fitting. Means shall be taken to eliminate the interference of

INSPECTION, TESTING AND MAINTENANCE

GENERAL

elements in contact or otherwise protect the components

necessary to determine origin of the problem before corrective action can be taken.

39 Hydraulic and pneumatic pumps and motors inspection.

- A. loose bolts or fasteners
- B. leaks at joints between sections
- C. shaft seal leaks
- D. unusual noises or vibrations
- E. loss of operating speed
- F. excessive heating of the fluid
- G. loss of pressure

40 Hydraulic and pneumatic valves inspection.

- A. cracks in valve housing
- B. improper return of spool to neutral position
- C. leaks at spools or joints
- D. sticking spools
- E. failure of relief valves to attain or maintain correct pressure setting
- F. relief valve pressure shall be checked as specified by the manufacturers

41 Hydraulic and pneumatic cylinders inspection.

- A. drifting caused by fluid leaking across piston
- B. rod seals leaking
- C. leaks at welding joints
- D. scored, nicked, or dented cylinder rods
- E. damaged case (barrel)
- F. loose or deformed rod eyes or connecting joints

42 Hydraulic filters. Evidence of rubber particles on the filter elements may indicate hose, "O" ring, or other rubber component deterioration. Metal chips or pieces on the filter may denote failure in pumps, motors, or cylinders. Further checking will be

43 Labels are to be in place and legible.

CRANES NOT IN REGULAR USE

44 A crane which has been idle for a period of over one month or more, but not less than six months, shall be given an inspection conforming with the initial-regular- frequent inspections.

45 A crane which has been idle for a period of over six months shall be given a complete inspection conforming with the initial-regular-frequent inspection requirements.

INSPECTION RECORDS

46 Dated records for periodic inspection should be made on critical items such as brakes, crane hooks, rope, hydraulic and pneumatic cylinders, and hydraulic and pneumatic relief pressure valves. Records should be kept available to an appointed person.

OPERATIONAL TESTS

47 Prior to initial use, all new, altered, modified, or extensively repaired cranes shall be tested for compliance with the operational requirements of this section, including functions such as the following:

- A. load lifting and lowering mechanisms
- B. boom lifting and lowering mechanisms
- C. boom extension and retraction mechanisms
- D. swing mechanisms
- E. safety devices
- F. operating controls comply with appropriate function labels

Operational crane test results shall be made available to an appointed person.

RATED TEST LOAD

Prior to initial use, altered, modified, or extensively repaired cranes shall be load

INSPECTION, TESTING AND MAINTENANCE

GENERAL

tested by or under the direction of an appointed person.

48 Test loads shall not exceed 110% of the manufacturer's load ratings.

49 Written reports shall be maintained showing test procedures and confirming the adequacy of repairs.

MAINTENANCE

PREVENTIVE MAINTENANCE

50 Before adjustment and repairs are started on a crane, the following precautions shall be taken as applicable:

- A. crane placed where it will cause the least interference with other equipment or operations
- B. all controls at the "off" position
- C. starting means rendered inoperative
- D. boom lowered to the ground if possible or otherwise secured against dropping
- E. relieve hydraulic oil pressure from all hydraulic circuits before loosening or removing hydraulic components

51 Warning or "OUT OF ORDER" signs shall be placed on the crane controls.

52 After adjustments and repairs have been made, the crane shall not be returned to service until all guards have been reinstalled, trapped air removed from hydraulic system (if required), safety devices reactivated, and maintenance equipment removed.

ADJUSTMENTS AND REPAIRS

53 Any hazardous conditions disclosed by the inspection requirements shall be corrected before operation of crane is resumed, Adjustments and repairs shall be done only by designated personnel.

54 Adjustments shall be maintained to assure correct functioning of components, The following are examples:

- A. functional operating mechanism
- B. safety devices
- C. control systems

55 Repairs or replacements shall be provided as needed for operation.

The following are examples:

- A. critical parts of functional operating mechanisms which are cracked, broken, corroded, bent, or excessively worn
- B. critical parts of the crane structure which are cracked, bent, broken, or excessively corroded
- C. crane hooks showing cracks, damage, or corrosion shall be taken out of service. Repairs by welding are not recommended

56 Instructions shall be provided by the manufacturer for the removal of air from hydraulic circuits.

LUBRICATION

All moving parts of the crane, for which lubrication is specified, should be regularly lubricated per the manufacturer's recommendations and procedures.

ROPE INSPECTION

57 Frequent Inspection

- A. All running ropes in service should be visually inspected once each working day. A visual inspection shall consist of observation of all rope which can be in use during the days operations. These visual observations should be considered with discovering gross damage such as listed below, which may be an immediate hazard.

- 1. distortion of the rope such as kinking, crushing, un-stranding, birdcaging, main strand displacement, or core protrusion. Loss of rope diameter in a short length or unevenness of outer strands should be replaced**

- 2. general corrosion**

INSPECTION, TESTING AND MAINTENANCE

GENERAL

3. broken or cut strands;
4. number, distribution and type of visible broken wires. When such damage is discovered, the rope shall either be removed from service or given as inspection.

B. Care shall be taken when inspecting sections of rapid deterioration such as flange points, crossover points, and repetitive pickup points on drums.

58 Periodic inspection

A. The inspection frequency shall be determined by a qualified person and shall be based on such factors as:

1. expected rope life as determined by experience on the particular installation or similar installations
2. severity of environment
3. percentage of capacity lifts
4. frequency rates of operation
5. exposure to shock loads

Inspection need not be at equal calendar intervals and should be more frequent as the rope approaches the end of it's service life. This inspection shall be made at least annually.

B. Periodic inspection shall be performed by a designated person. This inspection shall cover the entire length of the rope. Only the surface wires need be inspected. No attempt should be made to open the rope. Any deterioration results in appreciable loss of original strength, such as described below, shall be noted and determination made as to whether use of the rope would constitute a hazard: points listed above reduction of rope diameter below nominal diameter due to loss of core support, internal or external corrosion, or wear of outside wires; severely corroded, cracked, bent, worn or improperly applied connections;

C. Care shall be taken when inspecting sections subject to rapid deterioration such as the following:

1. sections in contact with saddles, equalizer sheaves, or other sheaves where rope travel is limited
2. sections of the rope at or near terminal ends where corroded or broken wires may protrude

ROPE REPLACEMENT

59 No precise rules can be given for determination of the exact time for replacement of rope, since many variable factors are involved.

Continued use in this respect depends upon good judgement by a designated person in evaluating remaining strength in a used rope after allowance for deterioration disclosed by inspection. Continued rope operation depends upon this remaining strength.

60 Conditions such as the following shall be reason for questioning continued use of the rope or increasing the frequency of inspection:

- A. in running ropes, six randomly distributed broken wires in one lay or three broken wires in one strand in one lay
- B. one outer wire broken at the contact point with the core of the rope structure and protrudes or loops out of the rope structure. Additional inspection of this section is required
- C. wear of one third of the original diameter of the outside individual wire
- D. kinking, crushing, birdcaging, or any other damage resulting in distortion of the rope structure
- E. evidence of any heat damage from any cause
- F. reduction from nominal diameter of more than 1/64 in. (0.4mm) for diameters up to and including 5/16 in. (8 mm), 1/32 in. (0.8 mm) for diameter 3/8 in. (9.5 mm) to and including 1/2 in. (13 mm), 3/64 in. (1.2 mm) for diameter 9/16 in. (14.5 mm) to and including 3/4 in. (19 mm). 1/16 in. (1.6 mm) for diameter 7/8 in. (22 mm) to and including 11/8 in. (29 mm), 3/32 in. (2.4 mm) for diameters 11/4 in. (32 mm) to and including 11/2 in. (38 mm)

INSPECTION, TESTING AND MAINTENANCE

GENERAL

G. In standing ropes, more than two broken wires in one lay in sections beyond end connections or more than one broken wire at an end connection.

H. Replacement rope shall have a strength rating at least as great as the original rope furnished or recommended by the crane manufacturer. Any deviation from the original size, grade, or construction shall be specified by a rope manufacturer, or a qualified person.

61 Rope not in regular use: all rope which has been idle for a period of a month or more due to shutdown or storage of a crane on which it is installed, shall be given an inspection in accordance with above information before it is placed in service. This inspection shall be for all types of deterioration and shall be performed by a qualified person.

62 Inspection records

- A. frequent inspection- no records required
- B. periodic inspections- in order to establish data as a basis for judging the proper time for replacement, a dated report condition at each periodic inspection should be kept on file. This report shall cover points of deterioration listed above.

ROPE MAINTENANCE

63 Rope should be stored to prevent damage or deterioration.

64 Unreeling or uncoiling of rope shall be done as recommended by the rope manufacturer and with care to avoid kinking or inducing twist.

65 Before cutting a rope, seizing shall be placed on each side of the place where the rope is to be cut to prevent unlaying of the strands. On pre-formed rope, one seizing on each side of the cut is required. On non-preformed ropes of 7/8 in. (22 mm) diameter or smaller, two seizings on each side of the cut are required, and for non-preformed rope 1 in. (25 mm) diameter or larger, three seizings on each side of the cut are required.

66 During installation care should be exercised to avoid dragging of the rope in the dirt or around objects which will scrape, nick crush or induce sharp bends in it.

67 Rope should be maintained in a well-lubricated condition. It is important that lubricant applied as a part of a maintenance program shall be compatible with the original lubricant and to this end the rope manufacturer should be consulted. Lubricant applied shall be the type which does not hinder visual inspection. Those sections of rope which are located over sheaves or otherwise hidden during inspection and maintenance procedures require special attention when lubricating rope. The object of rope lubrication is to reduce internal friction and to prevent corrosion.

68 When an operating rope shows greater wear or well defined localized areas than on the remainder of the rope, rope life can be extended in cases where a section at the worn end, and thus shifting the wear to different areas of the rope.

Safety Decal Section

5005EH

PART NO.: 040579
 DECAL: OPERATION INSTRUCTIONS
 FUNCTION: To inform the operator of the proper procedure to follow for safe operation of the crane.
 USED ON: All Cranes
 QUANTITY: 1
 PLACEMENT: Left side plate (5005EH)

FIG.

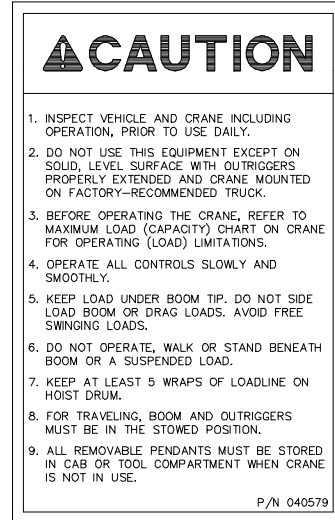

PART NO.: 040580
 DECAL: OPERATOR TRAINING
 FUNCTION: To inform the operator of the need to receive proper training before using the crane.
 USED ON: All Cranes
 QUANTITY: 1
 PLACEMENT: Left side plate (5005EH)

FIG. SD-2

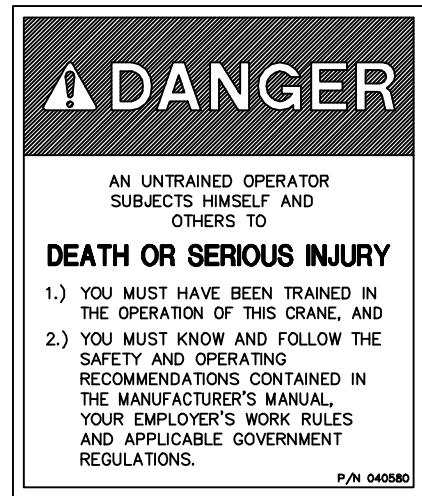

PART NO.: 040632
 DECAL: TAMPERING WITH OVERLOAD DEVICE
 FUNCTION: To inform the operator that tampering with the overload device may cause a unit failure or possible personnel injury.
 USED ON: 5005EH
 QUANTITY: 1
 PLACEMENT: Right side of lift cylinder

FIG. SD-3

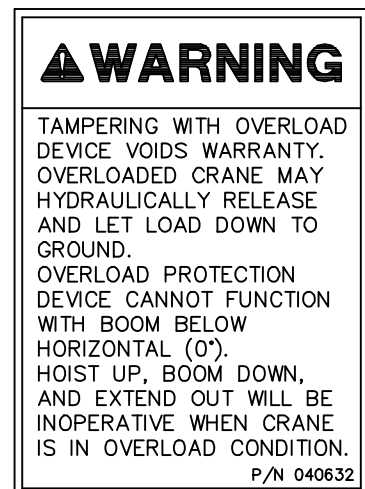

5-1.1.0

Safety Decal Section

5005EH

PART NO.: 040529
 DECAL: ELECTROCUTION HAZARD
 FUNCTION: To inform the operator of the hazard involved with contacting electrical power lines with crane boom.
 USED ON: Articulated & Stiff Boom Cranes
 QUANTITY: 2
 PLACEMENT: Both sides of end of lower boom

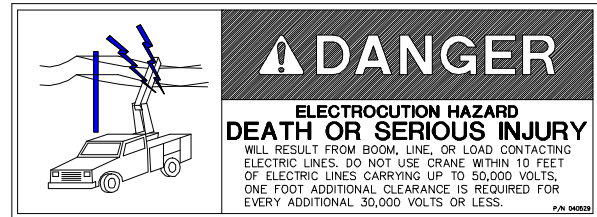

FIG. SD-4

PART NO.: 040517
 DECAL: STAY CLEAR OF BOOM
 FUNCTION: To inform the operator of the hazard of proximity or contact with the crane boom during operation.
 USED ON: All cranes
 QUANTITY: 2
 PLACEMENT: Both sides of crown

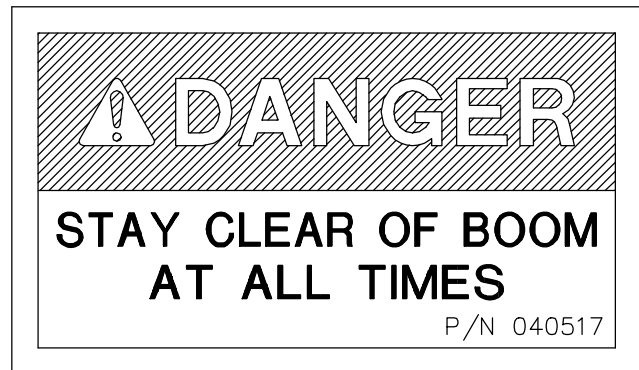

FIG. SD-5

PART NO.: 040518
 DECAL: STAY CLEAR OF LOAD
 FUNCTION: To inform the operator of the hazard of proximity or contact with the crane load during operation.
 USED ON: All cranes
 QUANTITY: 2
 PLACEMENT: Both sides of crown plate

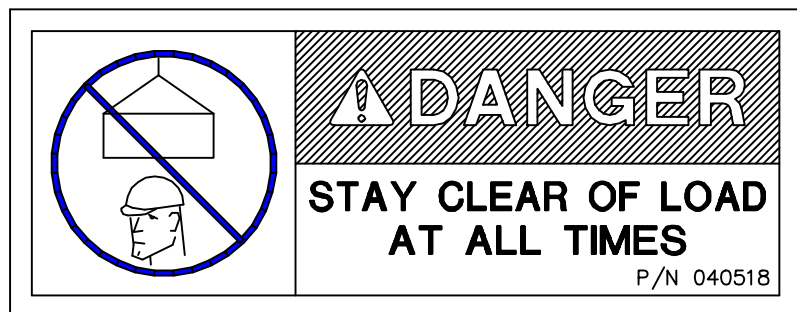

FIG. SD-6

Safety Decal Section

5005EH

PART NO.: 040587
DECAL: LOAD SENSOR, DON'T TAMPER
FUNCTION: To inform the operator that the load sensor is pre-set and that tampering with the sensor may cause potentially hazardous situation.
USED ON: All cranes equipped with a load sensor.
QUANTITY: 1
PLACEMENT: On the lift cylinder near the load sensor

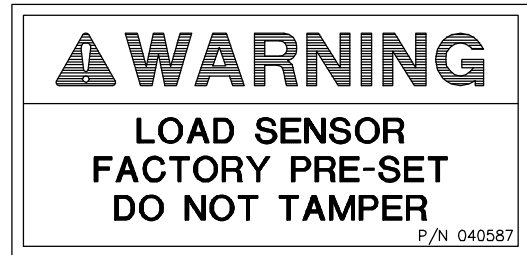

FIG. SD-7

PART NO.: 040519
DECAL: SCISSORS POINT
FUNCTION: To inform the operator of possible danger at scissors point on crane.
USED ON: All cranes
QUANTITY: 2
PLACEMENT: Both sides of the lift cylinder

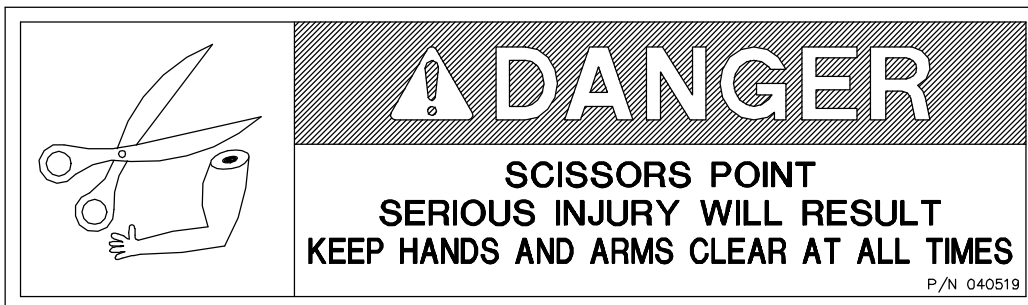
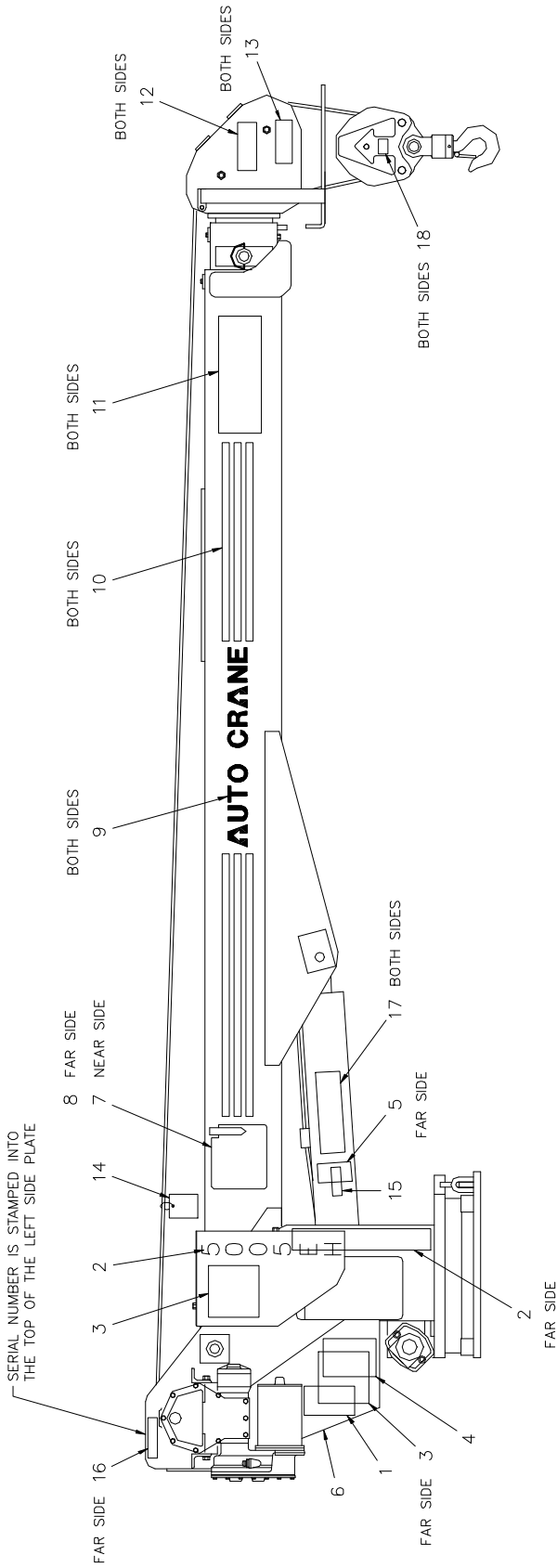
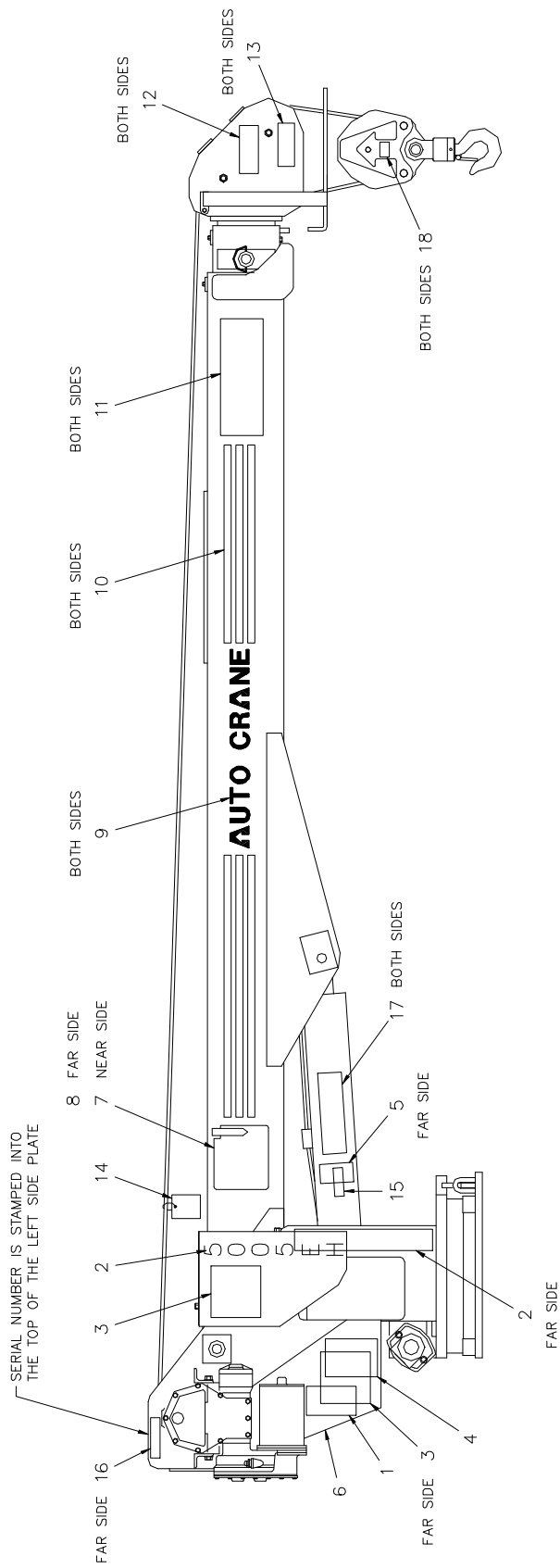

FIG. SD-8



AW-360809-100
5005EH DECAL LAYOUT (BLACK)

ITEM	QTY	PART NO.	DESCRIPTION	ITEM	QTY	PART NO.	DESCRIPTION
1	1	040579	DECAL, CAUTION-WORK RULES	10	13'	040620	STRIPING
2	2	360839-100	DECAL, 5005EH	11	2	040529	DECAL, DANGER-SHOCK
3	1	360838-100	DECAL, LOAD CHART	12	2	040517	DECAL, DANGER-STAY CLEAR
4	1	040580	DECAL, DANGER-OPERATE	13	2	040518	DECAL, DANGER-STAY CLEAR
5	1	040632	DECAL, DANGER-CYL. OPERATION	14	1	999960	INSTALLATION CHECKLIST
6	1	360034-100	DECAL, LOGO	15	1	040587	DECAL, WARNING-LOAD SENSOR
7	1	360036-100	DECAL, ANGLE INDICATOR, RIGHT	16	1	330622-100	DECAL, SERIAL NO.
8	1	360037-100	DECAL, ANGLE INDICATOR, LEFT	17	2	040519	DECAL, DANGER-SCISSOR POINT
9	2	040624-100	DECAL, AUTO CRANE	18	2	360480-100	DECAL, BLOCK WEIGHT & MAX. LOAD



ITEM	QTY	PART NO.	DESCRIPTION	ITEM	QTY	PART NO.	DESCRIPTION
1	1	040579	DECAL, CAUTION-WORK RULES	10	13'	040620	STRIPING
2	2	360839	DECAL, 5005EH	11	2	040529	DECAL, DANGER-SHOCK
3	1	360838	DECAL, LOAD CHART	12	2	040517	DECAL, DANGER-STAY CLEAR
4	1	040580	DECAL, DANGER-OPERATE	13	2	040518	DECAL, DANGER-STAY CLEAR
5	1	040632	DECAL, DANGER-CYL. OPERATION	14	1	999960	INSTALLATION CHECKLIST
6	1	360034	DECAL, LOGO	15	1	040587	DECAL, WARNING-LOAD SENSOR
7	1	360036	DECAL, ANGLE INDICATOR, RIGHT	16	1	330622	DECAL, SERIAL NO.
8	1	360037	DECAL, ANGLE INDICATOR, LEFT	17	2	040519	DECAL, DANGER-SCISSOR POINT
9	2	040624	DECAL, AUTO CRANE	18	2	360480-100	DECAL, BLOCK WEIGHT & MAX. LOAD

AW-360809
5005EH DECAL LAYOUT (BLUE)

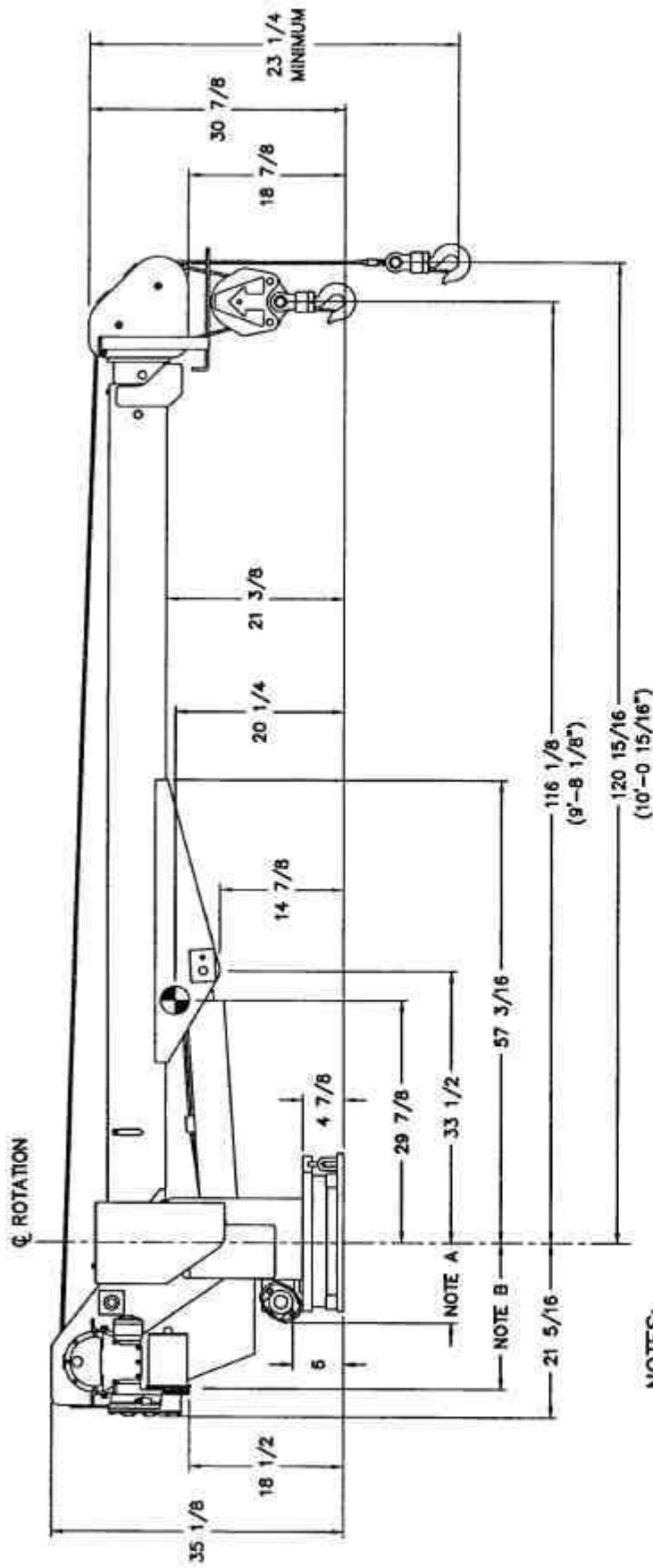

NOTES:

- A. MAX TURNING RADIUS AT ROTATION MOTOR = 14 1/2"
- B. MAX TURNING RADIUS AT HOIST ACTUATOR = 24 1/2"

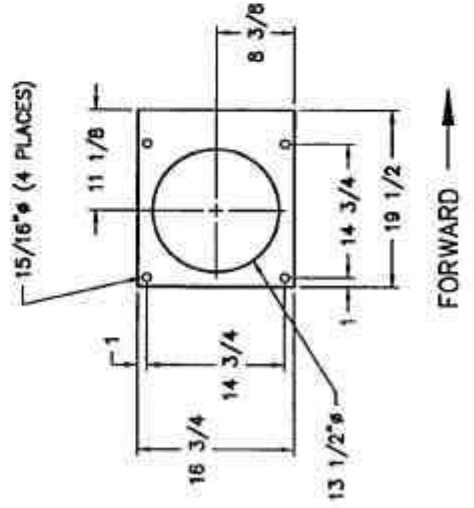

SPECIFICATIONS:

- LENGTH = 12'-0"
- WIDTH = 22 1/2"
- HEIGHT = 35 1/8"
- BOOM LENGTH = 10'-0 15/16" (SINGLE LINE, RETRACTED)
- BOOM EXTENSION = 6' POWER
- CRANE WEIGHT = APPROX. 1200 LBS.
- POWER SOURCE = 24 VOLT DC W/ HYD POWER UNIT
- REMOTE MOUNTED VOLTAGE SWITCHING UNIT AND PENDANT CONNECTION BOX
- 370° ROTATION
- HYD RELIEF SETTING = 2200 PSI
- MAX AMP DRAW FOR HOIST = APPROX. 95 AMPS
- MAX AMP DRAW FOR HYD UNIT = APPROX. 120 AMPS

**AW-361
5005EH GENERAL DIMENSIONS & SPECIFICATIONS (10-16)**

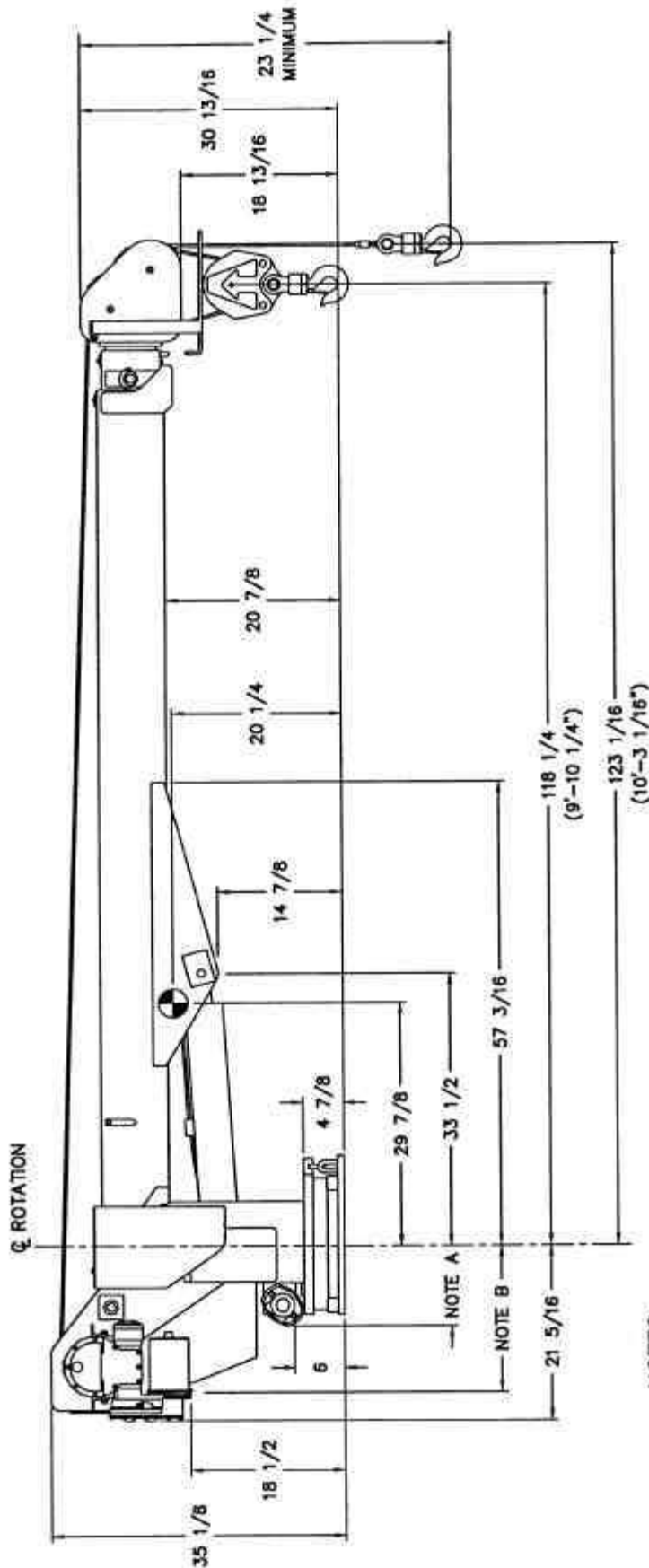

NOTES:

- A. MAX TURNING RADIUS AT ROTATION MOTOR = 14 1/2"
- B. MAX TURNING RADIUS AT HOIST ACTUATOR = 24 1/2"

SPECIFICATIONS:

- LENGTH = 12'-2"
- WIDTH = 22 1/2"
- HEIGHT = 35 1/8"
- BOOM LENGTH = 10'-3 1/16" (SINGLE LINE, RETRACTED)
- BOOM EXTENSION
 - POWER - 6'
 - MANUAL - 4'
 - TOTAL - 10'
- CRANE WEIGHT = APPROX. 1337 LBS.
- POWER SOURCE = 24 VOLT DC W/ HYD POWER UNIT
- REMOTE MOUNTED VOLTAGE SWITCHING UNIT AND PENDANT CONNECTION BOX
- 370° ROTATION
- HYD RELIEF SETTING = 2200 PSI
- MAX AMP DRAW FOR HOIST = APPROX. 95 AMPS
- MAX AMP DRAW FOR HYD UNIT = APPROX. 120 AMPS

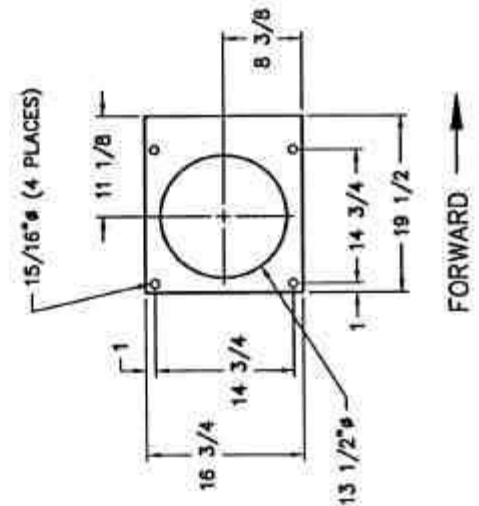

**AW-351
5005EH GENERAL DIMENSIONS & SPECIFICATIONS (10-16-20)**

1. DRILL 13/16 DIAMETER HOLE IN COMPARTMENT FLOOR OR BACK WALL. INSTALL CABLE AND BUSHING (No.BB-50 FURNISHED ON CABLE) AS SHOWN. WRAP ELECTRICAL TAPE AROUND CABLE TO GIVE THE WIRE A SNUG FIT IN BUSHING.
2. RUN CABLE INSIDE CHASSIS FRAME TO STARTER SOLENOID BATTERY CONNECTION. LOCATE CABLE SO THAT IT WILL BE PROTECTED, AVOID SHARP EDGES. INSTALL THE NO.838 FRAME CLIPS TO HOLD CABLE SECURELY IN PLACE. IF SURPLUS CABLE EXISTS, THE CABLE CAN BE CUT OFF, AND EXTRA TERMINAL FURNISHED WITH CABLE INSTALLED.
3. REMOVE NUT ON SOLENOID BATTERY TERMINAL POST, INSTALL CRANE POWER CABLE, REPLACE NUT AND TIGHTEN.
4. IF THE BATTERY IS GROUNDED TO THE ENGINE, IT MAY BE NECESSARY TO ADD AN ADDITIONAL GROUND CABLE FROM THE ENGINE TO THE CHASSIS FRAME IN ORDER TO OBTAIN MAXIMUM POWER AT THE CRANE. THE CRANE SHOULD BE GROUNDED TO THE CHASSIS FRAME. THIS IS USUALLY ACCOMPLISHED THROUGH THE BODY MOUNTING BRACKET.

CAUTION:
BOOM MUST BE PROPERLY SECURED IN PLACE, ON A BOOM SUPPORT BRACKET, WHEN CRANE IS NOT IN USE. (TO PREVENT GEAR DAMAGE)

BOOM SUPPORT BRACKET
AUTO CRANE P/N 726175
FOR 10-16-20 BOOM,
AUTO CRANE P/N 726173
FOR 10-16 BOOM

AW-350 5005EH INSTALLATION

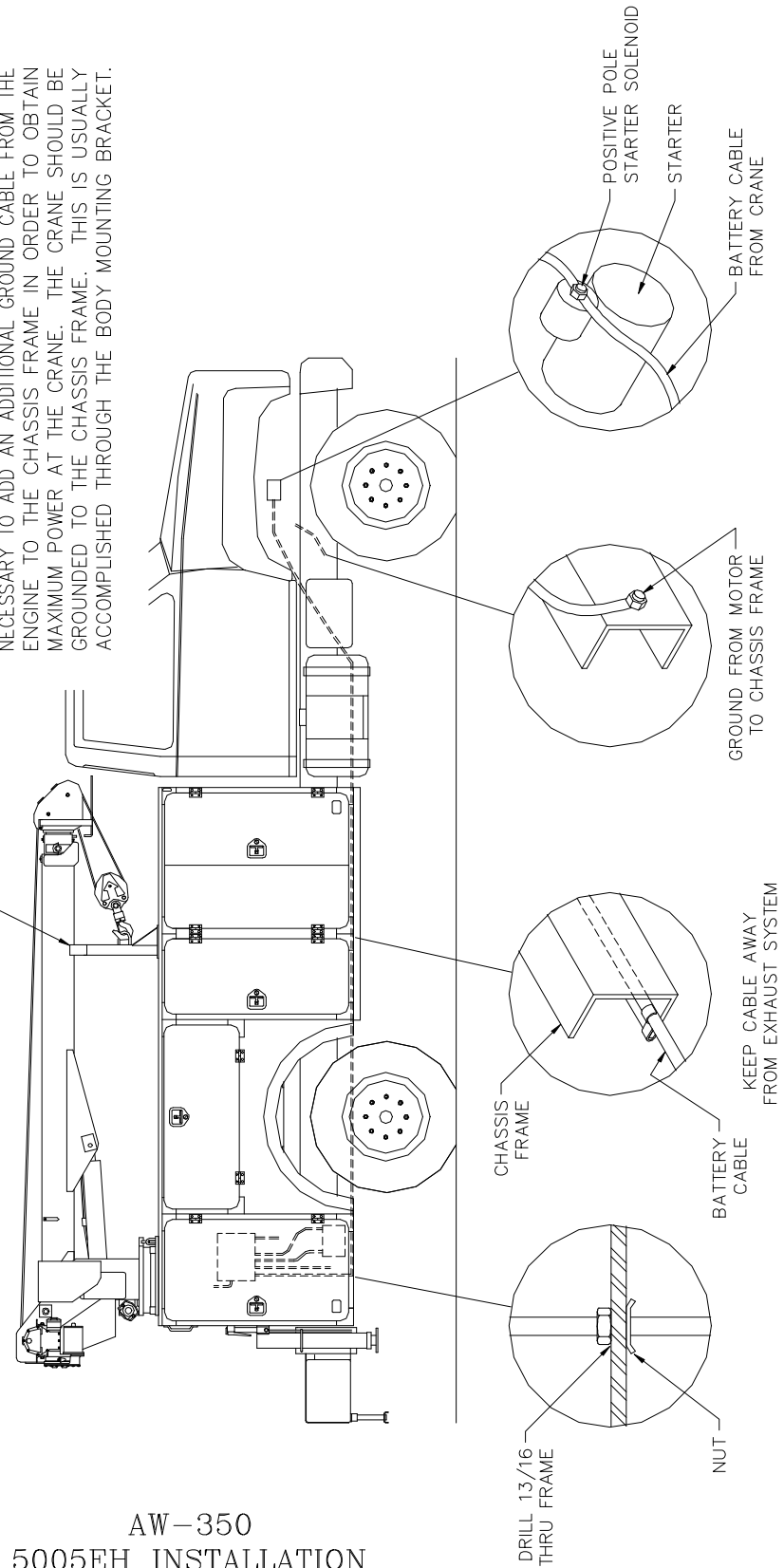

INSTALLATION (CRANE COMPARTMENT)

MODEL 5005EH

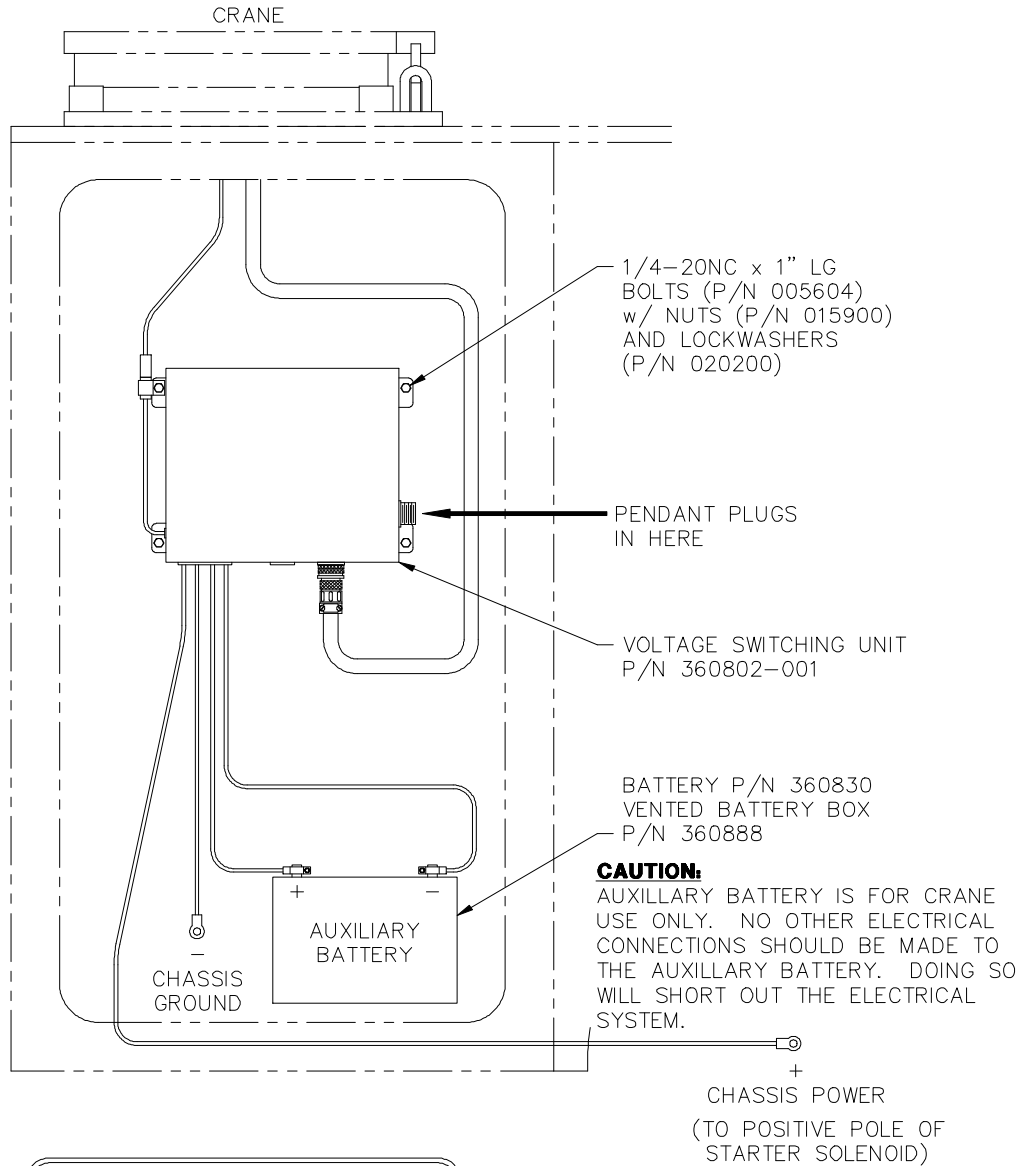

NOTICE:

WE RECOMMEND REPLACING ANY NO-MAINTENANCE TRUCK BATTERY WITH A MAINTENANCE TYPE TRUCK BATTERY

NOTE:

SEE ELECTRICAL SECTION FOR WIRING DIAGRAMS

BOOM SUPPORT

5005EH SERIES

WARNING:

As with all Auto Crane power rotation units, the 5005EH does require a boom support.

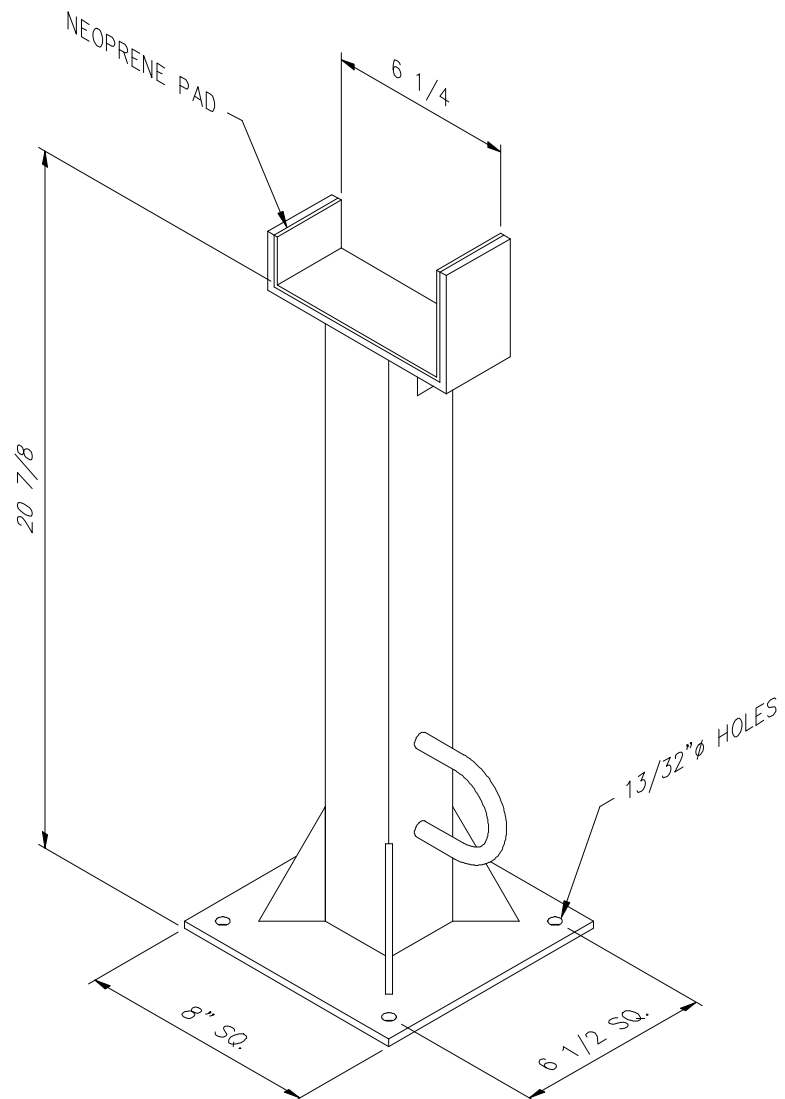

**Suggested Boom Support:
Auto Crane P/N 726175**

LUBRICATION & MAINTENANCE SCHEDULE

5005EH CRANE

SERVICE PERFORMED	DAY	WEEKLY	3 MOS	6 MOS	YEAR	NOTES
LOAD HOOK	X					INSPECT HOOK & LATCH FOR DEFORMATION, CRACKS, & CORROSION
CABLE DRUM	X					MAKE SURE CABLE IS WOUND EVENLY ON DRUM
HOIST CABLE	X					CHECK FOR FLATTENING, KINKS, & BROKEN STRANDS, SEE MANUAL
HYD. HOSES	X					VISUAL INSPECTION
HYD. FLUID	X					CHECK FLUID LEVEL
MOUNTING BOLTS		X				CHECK-TORQUE TO 440 FT-LBS (DRY) AS REQUIRED
ROTATION RING GEAR		X				LUBE WITH MOBILETAC LL, OR LUBRI-PLATE P/N 15263, OR EQUAL
SHEAVE BEARINGS		X				SEALED BEARING, REPLACE IF ROUGH OR LOOSE
ALL OTHER BOLTS		X				CHECK-TIGHTEN AS REQUIRED
BOOM PIVOTS		X				GREASE WITH MOBILPLEX EP-2 OR EQUIVALENT @ ZERKS
BOOM CYLINDER		X				CHECK AROUND CYLINDER ROD FOR EXCESS FLUID LEAKAGE
BOOM CYLINDER PINS		X				GREASE WITH MOBILPLEX EP-2 OR EQUIVALENT @ ZERKS
EXTENSION DETENT PIN		X				LUBE DETENT SPRING & BALL W/ WD-40
ROTATION BEARING			X			GREASE WITH MOBILPLEX EP-2 OR EQUIVALENT @ ZERKS
ROTATION BEARING BOLTS			X			CHECK TORQUE TO 150 FT-LBS (DRY) AS REQUIRED
ROTATION GEAR BOX			X			CHECK TORQUE TO 85 FT-LBS (DRY) AS REQUIRED
ROTATION GEAR BOX				X		EP GEAR LUBE SAE 140
HOIST GEARBOX				X		EP GEAR-EP GEAR LUBE SAE 80-90, SPUR GEAR SAE 30 OIL
HYDRAULIC FLUID					X	DRAIN, FLUSH, AND REFILL WITH SUN2105 HYD. OIL, SAE 5W-20
BOOM SLIDE PADS	PADS GREASED WHEN REPLACED					

LUBRICATION & MAINTENANCE SCHEDULE

5005EH CRANE

SERVICE PERFORMED	DAY	WEEKLY	3 MOS	6 MOS	YEAR	NOTES
FOR ADDITIONAL INFORMATION SEE:	1) OWNER'S MANUAL 2) OSHA SECTION 1910.180 3) ANSI B30.5-1989					

CAUTION: Routine maintenance insures trouble-free operation and protects your investment. All warranties are void if maintenance is neglected.

NOTES:

1. Use only authorized parts. Any damage or malfunction caused by the use of unauthorized parts is not covered by Warranty or Product Liability.
2. Once a bolt has been torqued to its rated capacity and then removed; the bolt should be replaced with a new one.
3. Auto Crane Company recommends that this crane be serviced per "Crane Inspection Log" P/N 999978. These logs should be filled in at the intervals noted and kept as a permanent record. Additional copies are available from your local distributor.

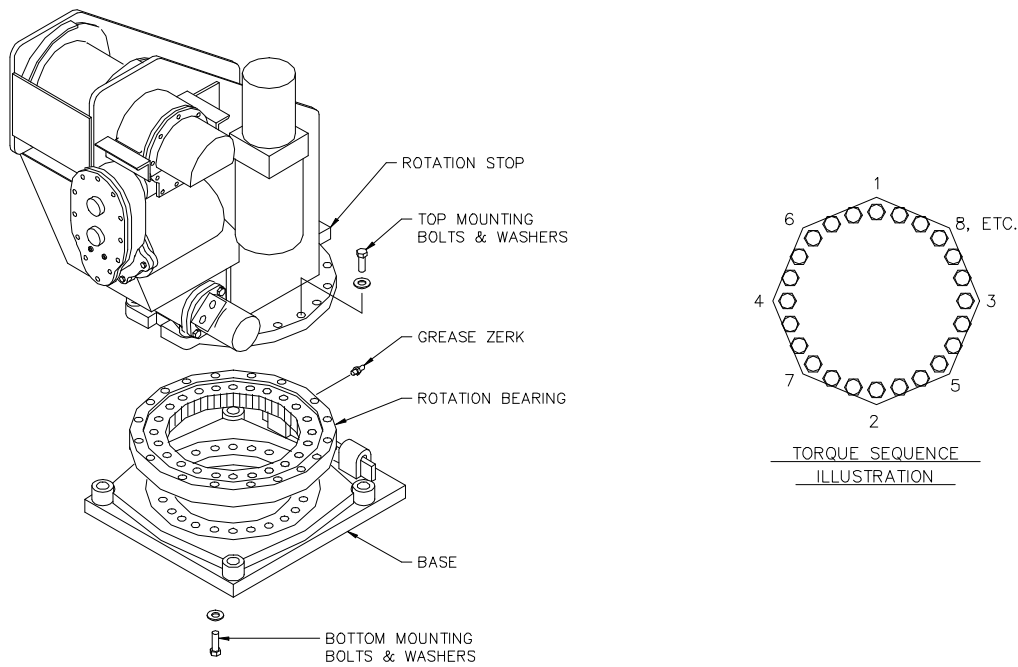

LUBRICATION OF ROTATION BEARING

RACE

1. LUBRICATE BEARING RACE AT THE GREASE ZERK LOCATED ON THE OUTSIDE OF THE ROTATION BEARING DIRECTLY UNDER THE ROTATION STOP OF THE PEDESTAL.
2. LISTED IN THE CHART BELOW ARE SEVERAL LUBRICANTS WHICH ARE ACCEPTABLE FOR BOTH RUST INHIBITING AND EXTREME PRESSURE CHARACTERISTICS.
 - A. LUBRICATE THE BEARING DAILY IF THE CRANE IS USED ON A DAILY BASIS.
 - B. LUBRICATE THE BEARING EVERY 30 DAYS IF THE CRANE IS USED INTERMITTENTLY.
 - C. ROTATE THE BEARING THROUGH TWO OR MORE ROTATIONS DURING LUBRICATION PROCCESS.

GEAR

1. THE CHART BELOW LISTS SEVERAL LUBRICANTS FOR THE GEAR. IT IS RECOMMENDED THAT THE TEETH BE LUBRICATED WITH A SMALL AMOUNT OF GREASE EVERY 8 HOURS IF THE CRANE IS USED DAILY. THE GREASE IS PURGED FROM THE TEETH BY THE VERY NATURE OF BEING EXPOSED TO THE ELEMENTS. THEREFORE CLOSE ATTENTION TO THE GEAR LUBRICANT WILL PROVIDE A LONGER TOOTH LIFE. GREASE THE GEAR TEETH AT THE PINION LOCATION.

INSTALLATION OF ROTATION BEARING

1. MAKE SURE MOUNTING SURFACES ARE FLAT AND CLEAR OF DEBRIS.
2. INSTALL BEARING SUCH THAT THE GREASE ZERK ON THE BEARING IS LOCATED DIRECTLY UNDER THE ROTATION STOP OF THE PEDESTAL.
3. INSTALL TOP AND BOTTOM BOLTS AND FLAT WASHERS. ALL BOLTS MUST BE GRADE 8 AND USED WITH HARDENED FLAT WASHERS. REFER TO PEDESTAL ASSEMBLY FOR PART NUMBERS.
4. SNUG ALL BOLTS , THEN TIGHTEN ACCORDING TO THE TORQUE SEQUENCE ILLUSTRATION UNTIL ALL BOLTS ARE TORQUED TO 150 FT.-LBS (NON-PLATED) OR 110 FT.-LBS (PLATED).

NOTE: BOLTS SHOULD BE CHECKED PERIODICALLY AND RETIGHTENED TO PROPER TORQUE.

5. GREASE THE ROTATION BEARING ACCORDING TO LUBRICATION INSTRUCTIONS AT LEFT.
6. SET BACKLASH OF THE ROTATION ACTUATOR AND THE ROTATION BEARING AT THE HIGH POINT OF THE ROTATION BEARING GEAR TEETH. IDENTIFIED BY A YELLOW PAINT MARK ON THE TEETH.

	MOBIL	TEXACO	SUNOCO	PURE	SOHIO	LUBRIPLATE
RACE	MOBILPLEX EP #2	MARFAC MP #2	PRESTIGE 742EP	POCO HT EP #2	SOHITRAN EP #1	---
GEAR	MOBILCOTE-S	CRATER COMPOUND	407 COMPOUND B	POCO GEARSHIELD	SOHITAC #1	GEARSHIELD EXTRA HEAVY #L0152-063

AW-346
ROTATION BEARING MAINTENANCE

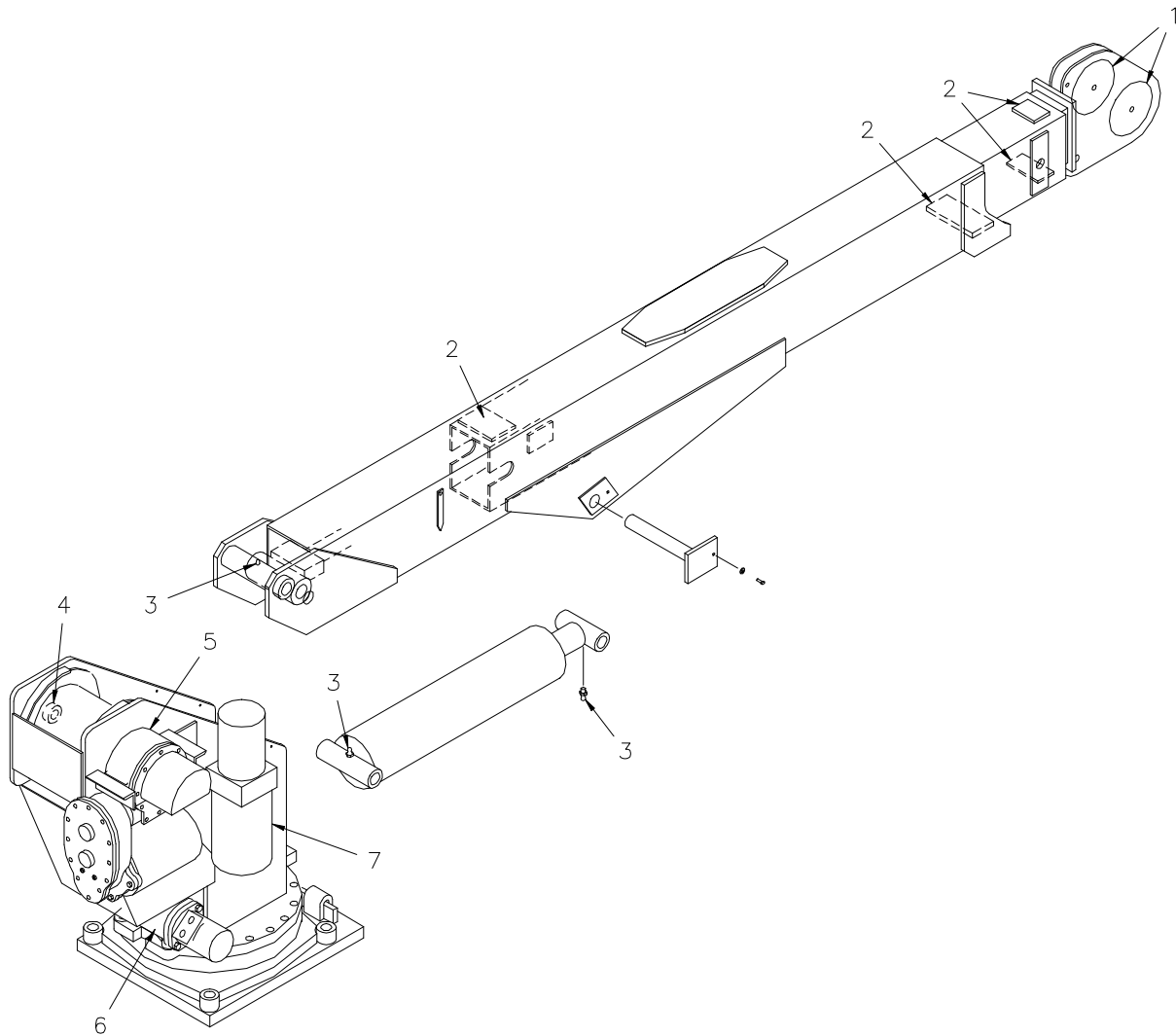

- | | |
|---|--|
| <p>1. SHEAVE ROLLER BEARINGS:
SEALED TYPE, NO LUBE REQUIRED.</p> <p>2. BOOM PADS:
IF REPLACED, GREASE UPON INSTALLATION WITH CHASSIS LUBRICANT.</p> <p>3. PIVOT POINT GREASE ZERKS:
LUBE ONCE A WEEK WITH MOBILPLEX EP-2 OR EQUIVALENT.</p> <p>4. HOIST ROLLER BEARINGS:
SEALED TYPE, NO LUBE REQUIRED.</p> | <p>5. HOIST ACTUATOR:
MAINTAIN GEAR BOX LUBRICANT AT FILL PLUG. USE ONE PINT OF EP GEAR LUBE SAE 80-90. REPLACE EVERY SIX MONTHS.</p> <p>6. ROTATION ACTUATOR:
MAINTAIN OIL LEVEL OF 1 1/2 PINTS OF EP GEAR LUBE, SAE 140. REPLACE EVERY SIX MONTHS.</p> <p>7. HYDRAULIC FLUID:
USE DTE-13 OR EQUIVALENT. RESERVOIR SHOULD BE FLUSHED AND NEW FLUID ADDED ONCE A YEAR, OR IF A HYDRAULIC FAILURE OCCURS.</p> |
|---|--|

AW-347
5005EH LUBRICATION MAINTENANCE

MAINTENANCE OF BATTERIES

Maintenance of Auto Crane unit batteries differs very little from the generally prescribed maintenance of any lead acid battery. All batteries must be kept *properly charged, properly filled with water, and relatively clean.*

Keep Properly Charged

Many things affect the proper charge to a battery, such as:

- 1 Regulator settings
- 2 Proper tightness of belts on the alternator or generator
- 3 Good, clean connections of all cables and wires at the following places:
 - A. Battery
 - B. Regulator
 - C. Starting motor
 - D. Alternator or generator
 - E. Ground connections (most important)

It is of extreme importance to keep the battery as fully charged as possible without overcharging, especially when vehicles are left outside for extended periods in extremely cold climates. A battery *can* freeze. Freezing points for various specific gravities of acid are as follows:

Specific Gravity (Corrected to 80°F)	Freezing Temp. Degrees F.
1.280	-90°F
1.250	-62°F
1.200	-16°F
1.150	5°F
1.100	19°F

As shown, a half-charged battery (about 1.200 specific gravity) cannot stand for any length of time at 20°F or it will freeze.

The *main reason* for keeping the battery as fully charged as possible without over-charging is to ensure that power is available even though the vehicle has been standing for some time.

Keep Properly Filled with Water

The battery should *always* be properly filled with water. If the electrolyte level is allowed to fall below the top of the plates, the results become threefold:

- 1 The exposed portion of the plate will become sulfated.
- 2 The portion of the plate exposed is not usable.
- 3 That portion of the acid remaining becomes more concentrated and may cause more rapid deterioration of the remaining parts of the battery.

Keep A Relatively Clean Battery

The battery should be kept clean. Batteries filled with acid and which are not in use self-discharge to a limited degree because of the nature of the materials within the battery. If dirt is allowed to collect on the top of the battery (and this dirt absorbs moisture) and electrical path can be set up between the various terminals of the battery and the ground. Once such a path has been established, the self-discharge of the battery is accelerated. This also accelerates corrosion of the battery cables at the terminals.

Periodic Maintenance is Needed

A definite program of periodic maintenance of all batteries should be conducted on a regular basis. Periodic maintenance includes:

- 1 Checking belts for tightness on the charging equipment
- 2 Checking battery electrolyte levels
- 3 Checking cables for good connections
- 4 Cleaning where corrosion is apparent

When corrosion is cleaned off, the cable terminals and battery terminals should be coated with a light coating of petroleum jelly before they are replaced. When terminals are cleaned, the top of the battery should be cleaned with a mild solution of soda water.

MAINTENANCE OF BATTERIES

Low Maintenance Batteries (Maintenance Free)

Low maintenance batteries should not be used on Auto Cranes or trucks equipped with Auto Cranes. The batteries are not designed for "deep" discharge.

Testing Your Battery

If the condition of the battery is in question, it should be removed from the vehicle, taken to the shop, and allowed to reach room temperature. It should then be recharged until specific gravity readings taken at one-half hour intervals. If the specific gravity readings are fairly uniform, the battery should be checked with a high rate tester. Use the tester in accordance with the manufacturer's instructions. The high rate tester is the best method to test a questionable battery.

If, after charging, it is noted that the specific gravity reading of one cell is 30 points less than any of the other cells, it may be assumed that the cell is bad and that the battery should be replaced. If all cells are uniform but not up to full charge, a low rate of charge

should be attempted for an extended time. This usually will recover a badly sulfated battery.

Replacing a Battery

If it is necessary to replace a battery, and a dry charge battery is used, the following procedure applies:

- 1 Fill the battery with electrolyte of the proper specific gravity.
- 2 Place the battery on charge according to the manufacturer's instructions.

It is essential that the second step above be followed to ensure that the battery going on the vehicle is fully charged.

It is also very important that the battery hold-downs be checked periodically to ensure that the batteries are properly positioned to avoid vibration problems, breakage of cables or terminals. Care must be taken to avoid cracking or breaking containers or covers by tightening hold-down fixtures excessively. They also must not be so loose that breakage results from a hold-down that is too loose.

LIFE OF WIRE LINE

So many variable factors can cause the deterioration of wire line cable that it is not possible to determine a definite life expectancy. Some of these factors are:

- **Load being handled.**
- **Corrosive conditions.**
- **Maintenance of the unit:**
 - Keep the sheaves turning freely.
 - Maintain tension on cable to insure proper spooling.
 - Avoid kinks in cable.
 - Avoid abrasive action and contact with sharp corner.
- **Frequency of use.**

Auto Crane units, up to 2,400 pound ratings use 3/16 inch diameter galvanized pre-formed 7 x 19 aircraft cable. This cable has a working strength, when new, of 4,200 pounds. It is recommended when 1,200 pound loads are exceeded to use a two part line with a traveling block. This will ensure a 3.5 to 1 safety factor when the cable is new.

Keeping the above factor of safety in mind and knowing the kind of loads that will be handled, the user can determine by inspection of the cable as to when it should be replaced.

Items to look for while inspecting the cables are:

- Broken strands.
- Kinks and flattened sections.
- Corrosion and abrasion.

WIRE LINE LUBRICATION

Lubrication of the wire line serves two important purposes:

- Prevent corrosion.
- Reduce wear due to flexing and abrasion caused by contact with the sheaves, rollers, and cable on the drum.

Preparation

Remove rust and foreign matter with a wire brush and wipe clean. Be sure cable is dry.

Application

Method 1: Dip a brush into a light weight motor oil and apply. In some cases, dip a rag or a piece of sheepskin into the lubricant and swab the lubricant on to the rope.

Method 2: Apply a heavier lubricant such as a grease gun lubricant with hands while wearing leather gloves. (Leather gloves give greater protection and less penetration of the grease than canvas gloves.)

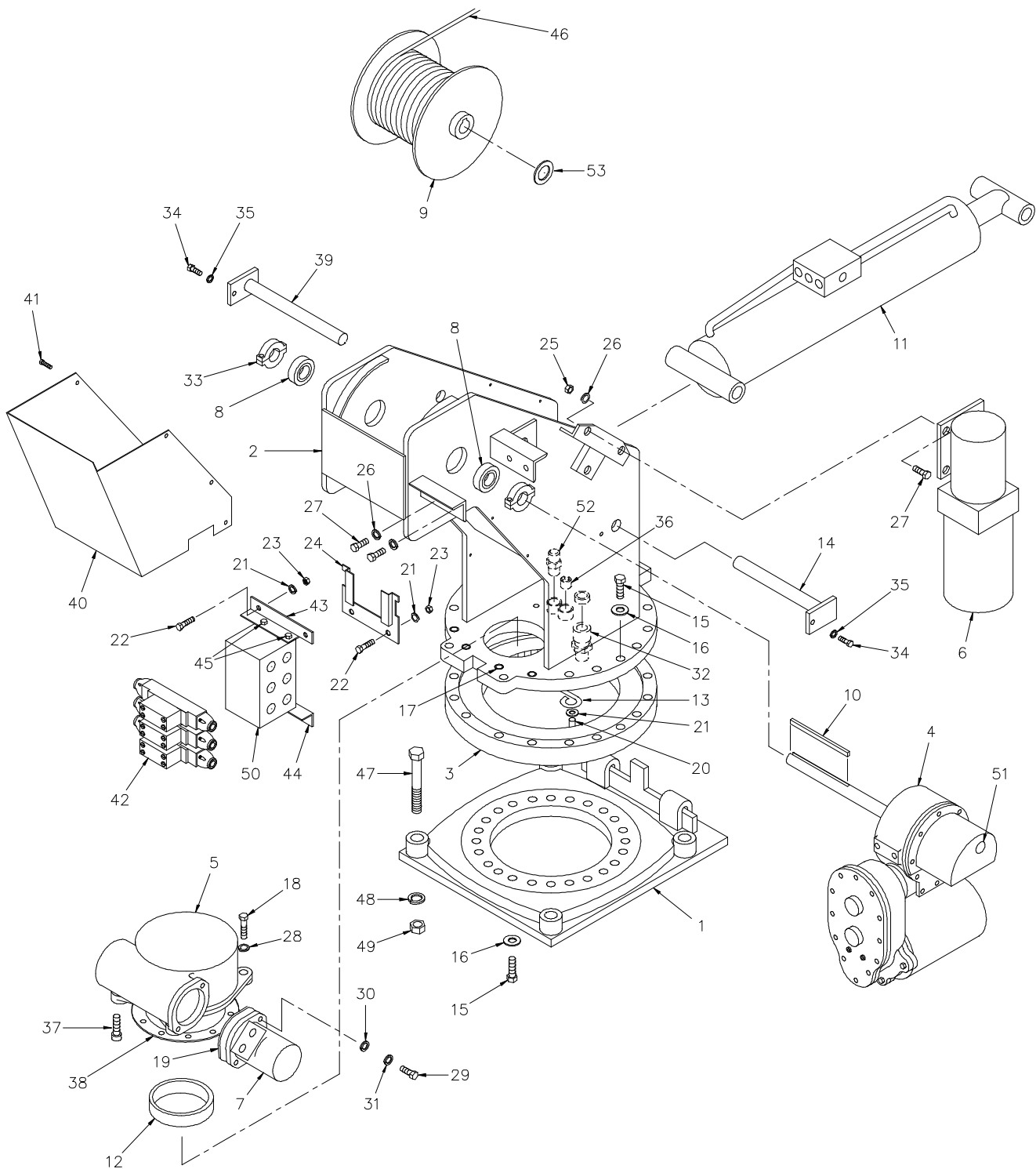

AW-360801
5005EH PEDESTAL ASSEMBLY

10-1.0.0

R 10/96

AW-360801
5005EH PEDESTAL ASSEMBLY

ITEM	QTY.	PART NO.	DESCRIPTION
1	1	360536	BASE PLATE ASSEMBLY
2	1	360825	PEDESTAL WELDMENT
3	1	480023-002	ROTATION BEARING
4	1	360807	WINCH, 24V
5	1	480028	ROTATION GEAR BOX
6	1	360798	POWER UNIT, (HYD. PUMP & RESERVOIR)
7	1	480027	MOTOR, HYD. (ROTATION)
8	2	400500	BEARING
9	1	360543	DRUM, HOIST
10	1	360557	KEY, 5/16
11	1	360805	CYLINDER, BOOM UP
12	1	360162	RING, ECCENTRIC
13	1	360207	RETAINER, ECCENTRIC RING
14	1	360624	PIN, PEDESTAL/CYLINDER
15	38	012198	SCREW, HX HD 5/8NC X 1 3/4 G8
16	38	023902	WASHER, FLAT 5/8 HARDENED
17	4	006205	SCREW, HX HD 5/8NC X 1 1/4 G8
18	2	011608	SCREW, HX HD 1/2NC X 2 G5
19	1	480019	GASKET, MOTOR
20	1	007402	SCREW, HX HD 5/16NC X 5/8 G5
21	7	020600	WASHER, SP LK 5/16
22	6	007811	SCREW, HX HD 5/16NC x 1
23	6	016500	NUT, HEX 5/16NC
24	1	366987	RETAINER, RELAY BOX
25	3	017100	NUT, HEX 3/8NC
26	7	021100	WASHER, SP LK 3/8
27	7	008601	SCREW, HX HD 3/8NC X 7/8 G5
28	2	021500	WASHER, SP LK 1/2
29	2	012197	SCREW, SOC HD 1/2NC X 1 1/2 G5
30	2	021502	WASHER, SP LK 1/2 (HI-COLLAR)
31	2	021601	WASHER, FLAT 1/2 SAE (SPECIAL)
32	1	370433	CABLE CONNECTOR
33	2	330468	COLLAR, SPLIT-LOCK
34	2	005500	SCREW, HX HD 1/4NC X 3/4
35	2	020200	WASHER, SP LK 1/4
36	1	750477	PLUG, PIPE 1/2
37	2	009118	SCREW, SOC HD 1/2NC X 2 G5
38	1	480011	SEAL, ROTATION BOX
39	1	360625	PIN, LOWER BOOM PIVOT
40	1	360867	COVER
41	6	002608	SCREW, HX HD 1/4NC X 3/4 S.T.
42	3	300204	DIRECTIONAL VALVE ASSEMBLY
43	1	320392	BRACKET, MANIFOLD (TOP)
44	1	320393	BRACKET, MANIFOLD (BOTTOM)
45	4	002614	SCREW, HX HD 5/16NC X 5/8 S.T.
46	1	360155	WIRE ROPE ASSEMBLY, 5/16
47	4	015104	SCREW, HX HD 7/8NF X 5 G8
48	4	022200	LOCKWASHER, 7/8

AW-360801
5005EH PEDESTAL ASSEMBLY

ITEM	QTY.	PART NO.	DESCRIPTION
49	4	018900	NUT, HEX 7/8NF
50	1	202710	MANIFOLD
51	1	360848	PLUG, PLASTIC 1"ø
52	1	642908	CORD CONNECTOR
53	2	480073	SPACER, WINCH SHAFT

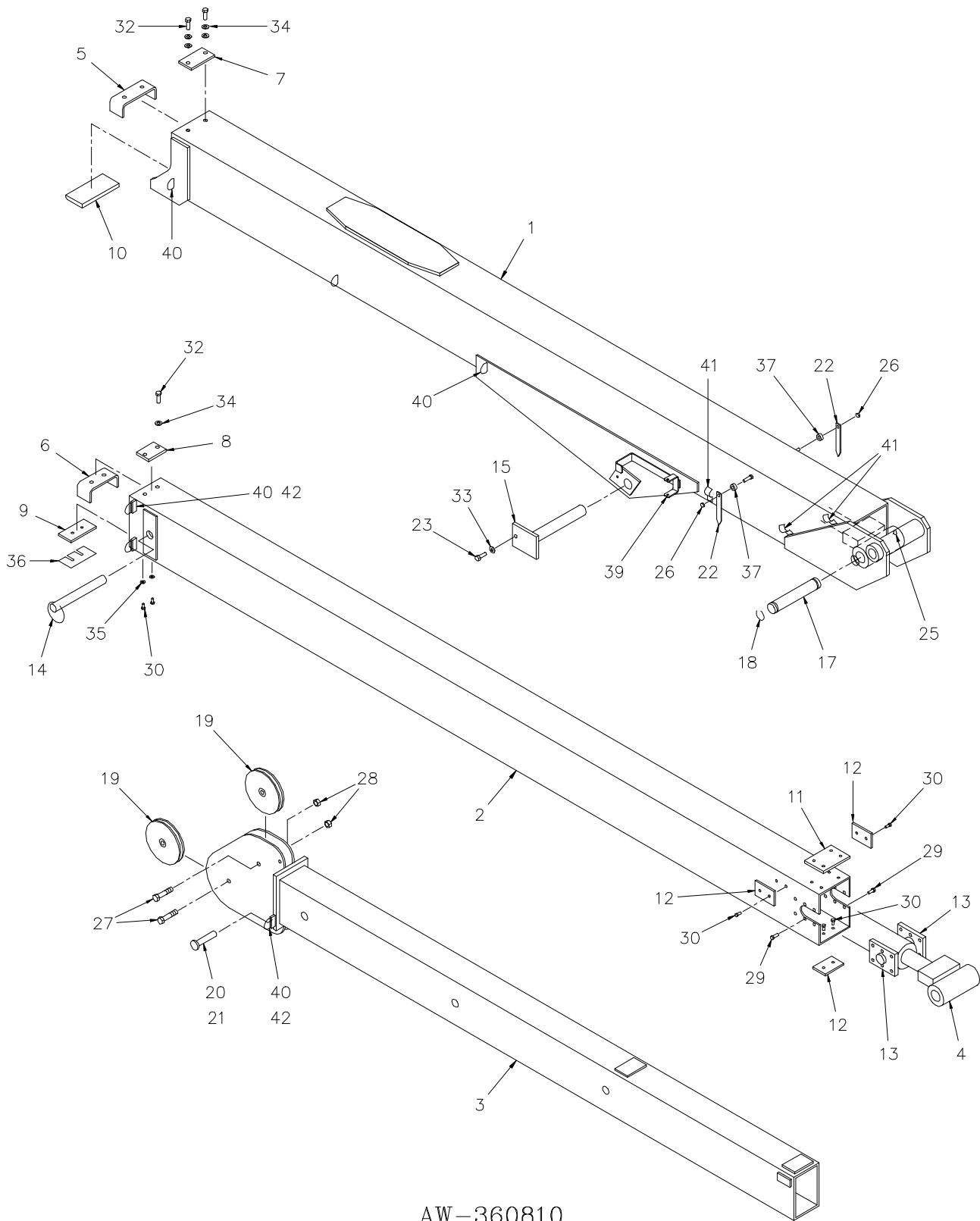

AW-360810
 5005H/EH BOOM ASSEMBLY
 10-16-20

10-2.0.0

R 10/96

AW-360810
5005H/EH BOOM ASSEMBLY (10-16-20 BOOM)

ITEM	QTY.	PART NO.	DESCRIPTION
1	1	360815	BOOM, LOWER
2	1	366080	BOOM, CENTER
3	1	360820	BOOM, MANUAL
4	1	366162	CYLINDER, BOOM EXTENSION
5	1	366183	STOP, CENTER BOOM
6	1	366112	STOP, UPPER BOOM
7	1	366201	PAD, BOTTOM TOP
8	1	366202	PAD, BOOM TOP
9	1	366199	PAD, BOOM
10	1	366187	PAD, RETAINER LOWER
11	1	366185	PAD, BOOM TOP (CENTER BOOM)
12	3	366186	PAD, BOOM (CENTER BOOM)
13	2	366184	RETAINER, EXTENSION CYLINDER
14	1	366190	PIN, ASSEMBLY WITH LANYARD
15	1	360819	PIN, BOOM CYLINDER
16	-	-	-
17	1	366193	PIN, EXTENSION CYLINDER
18	2	480029	RING, RETAINING
19	2	240236	SHEAVE ASSEMBLY
20	1	360814	PIN, CROWN
21	1	360124	PIN, HITCH
22	2	360038	ANGLE INDICATOR
23	1	366158	SCREW, HEX HD 3/8NC X 3/4 GR.8
24	-	-	-
25	1	239000	GREASE ZERK
26	2	016300	NUT, HEX LK 1/4NC
27	2	011511	SCREW, HEX HD 1/2NF X 2 1/4 GR.5
28	2	017700	NUT, HEX LK 1/2NF
29	12	008400	SCREW, HEX HD 3/8NC X 3/4
30	8	007808	SCREW, HEX HD 5/16NC 1/2
31	4	005406	SCREW, HEX HD 1/4NF X 1/2
32	4	008800	SCREW, HEX HD 3/8NF X 1
33	5	021100	WASHER, SP LK 3/8 SAE
34	6	021200	WASHER, FLAT 3/8
35	2	020600	WASHER, SP LK 5/16
36	A/R	480037	SHIM
37	2	360849	SPACER, PLASTIC 1/4"Ø
38	1	366166	SEAL KIT
39	1	REF	CORD REEL BRACKET (320551)
40	6	REF	D-RING (366108)
41	3	REF	CLIP (000115)
42	3	REF	SPACER (800246-025)

BOOM ASSEMBLY (10-16)

P/N 360860 - MODEL 5005H/EH

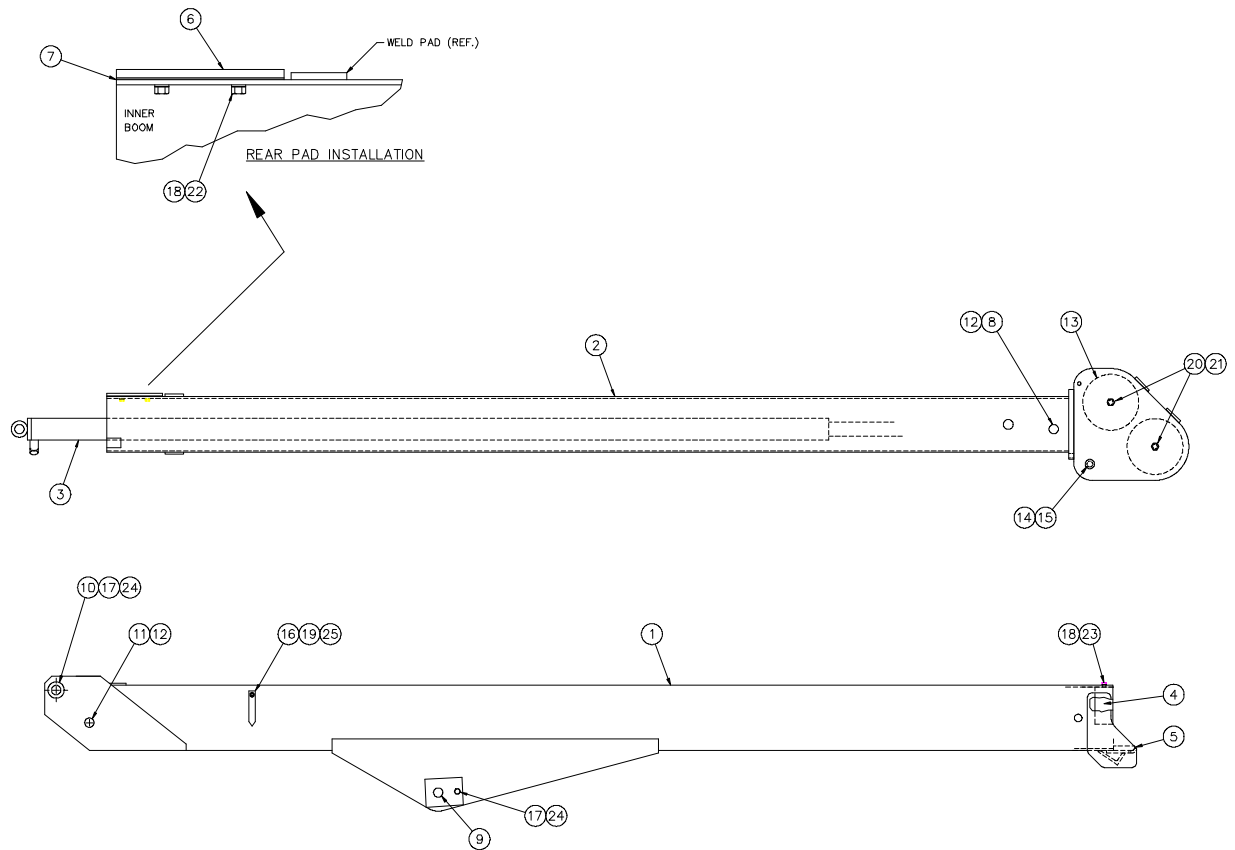

BOOM ASSEMBLY (10-16)

P/N 360860 - MODEL 5005H/EH

<u>ITEM</u>	<u>QTY</u>	<u>P/N</u>	<u>DESCRIPTION</u>
1	1	360861	LOWER BOOM
2	1	360862	UPPER BOOM
3	1	360152	BOOM EXTENSION CYLINDER
4	1	360545	INNER BOOM RETAINER
5	1	360167	LOWER SLIDE PAD RETAINER
6	1	480032	BOOM PAD
7	2	480033	LARGE SHIM .032 THICK
8	1	360121	UPPER BOOM EXTENSION CYLINDER PIN
9	1	360621	BOOM/CYLINDER PIN
10	1	360625	LOWER BOOM PIVOT PIN
11	1	360120	LOWER BOOM EXTENSION CYLINDER PIN
12	4	360122	RETAINING RING
13	2	240236	SHEAVE ASSEMBLY
14	1	360814	CROWN PIN
15	1	360124	HITCH PIN
16	2	360038	ANGLE INDICATOR
17	2	366158	CAPSCREW 3/8-16NC x 3/4
18	6	020200	SPLIT LOCK WASHER 1/4
19	2	016300	HEX LOCK NUT 1/4-20NC
20	2	011511	CAPSCREW 1/2-20NF x 2 1/4
21	2	017700	HEX LOCK NUT 1/2-20NC
22	4	005406	CAPSCREW 1/4-28NF x 1/2
23	2	005901	CAPSCREW 1/4-20NC x 1/2
24	2	021100	SPLIT LOCK WASHER 3/8
25	2	360849	PLASTIC SPACER
26	5	015900	HEX NUT 1/4-20NC
27	1	360069	EXTENSION CYLINDER TUBE ASSEMBLY
28	1	360070	EXTENSION CYLINDER TUBE ASSEMBLY
29	2	360075	EXTENSION CYLINDER HOSE ASSEMBLY
30	1	360091	U-BOLT
31	1	360092	CLAMP
32	1	360153	COUNTERBALANCE VALVE

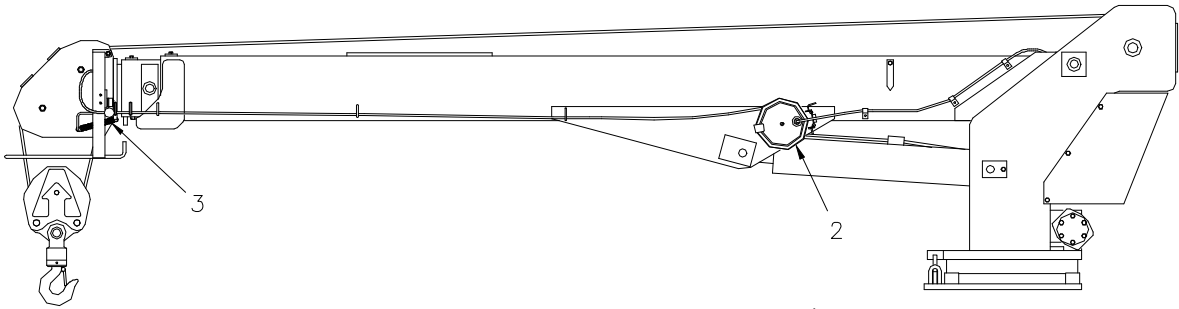

CORD REEL & 2-BLOCK ASS'Y

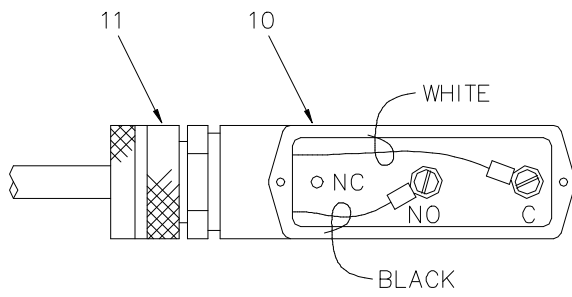

REFERENCE-SWITCH WIRING

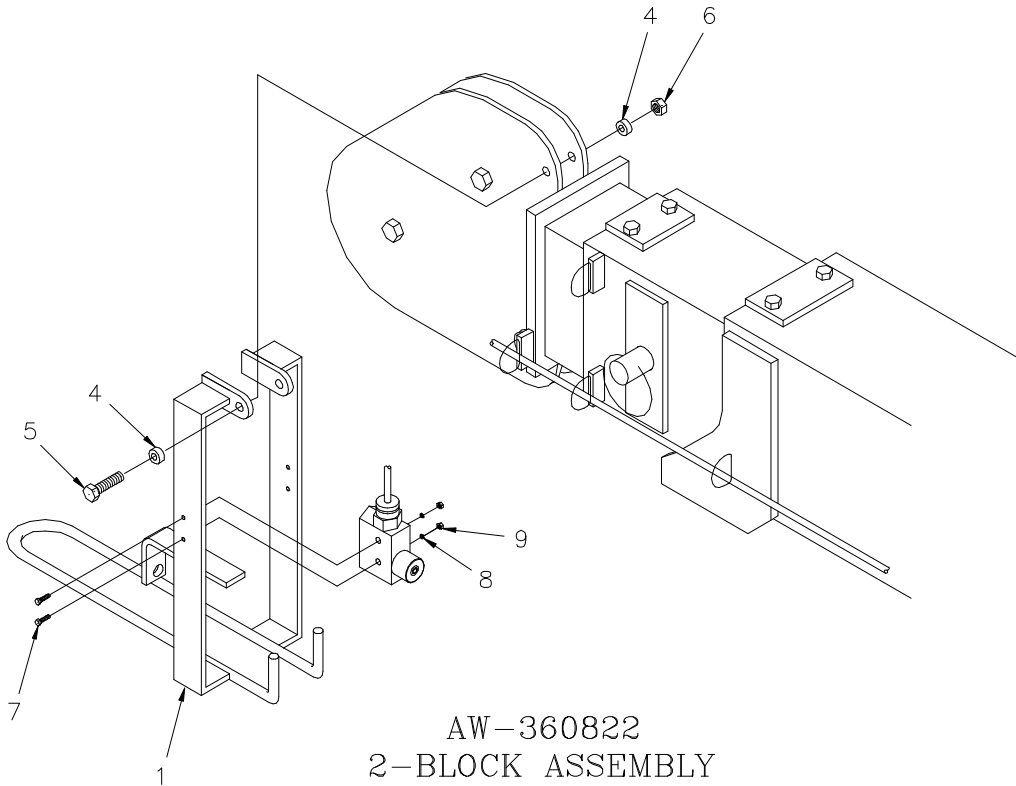

AW-360822
2-BLOCK ASSEMBLY
5005H/EH

AW-360822
2-BLOCK ASSEMBLY, 5005H/EH

ITEM	QTY.	PART NO.	DESCRIPTION
1	1	360823	2-BLOCK WELDMENT
2	1	366973-001	CORD REEL ASSY w/WEATHER PACK CONNECTORS
3	1	360824	SPRING, 2-BLOCK
4	2	360852	SPACER, PLASTIC
5	1	009800	SCREW, HX. HD. 3/8-24NF X 3 1/2 LG.
6	1	017400	NUT, LOCK 3/8-24NF
7	2	000610	SCREW, ROUND HD. #6-32NC X 1 1/2 LG.
8	2	019600	WASHER, SP. LK. #6
9	2	015400	NUT, #6-32NC
10	1	646900	SWITCH
11	1	642908	CORD CONNECTOR

OVERLOAD SYSTEM / ANTI-2-BLOCK

TROUBLE SHOOTING GUIDE

IF THE THREE FUNCTIONS, BOOM DOWN, HOIST UP AND EXTEND OUT, QUIT WORKING,

the problem probably lies in either the Overload System or the Anti-2-block system or both. If these three functions are NOT WORKING and most other functions are, an investigation should be made as follows: (reference: Figure 1)

1 ANTI-2-BLOCK

- A. Unplug the anti-2-block system from the overload system and connect A and B to bypass the anti-2-block system.
 - 1. **If the three functions work, check continuity of anti-2-block system using continuity tester at disconnected. Weather pack connectors, and investigate switch at end of boom, cable and cable reel.**
 - 2. **If the three functions do not work, continue on with section #2.**

2 LOAD SENSOR (Pressure Switch)

- A. With crane unloaded, unplug weather pack connector on load sensor wire.
 - 1. **If the three functions work, recheck the Pressure Switch by taking a ohm reading on the two wires coming from the Switch. The switch has normally open contacts, so the reading should be the maximum. If less than maximum ohm reading is indicated (usually a dead short), replace the Switch.**
 - 2. **If the three functions do not work, continue with section #3.**

3 RELAY BOX

- A. Inside this box are two 320355 relays. Since these are inexpensive relays, the easiest way to trouble shoot this device is to replace both relays.
 - 1. **The two relays are identical but serve different functions. RELAY A is the one with the most wires going to its connector. RELAY A breaks the circuit between the ground side of the solenoid valves on boom down, extend out, and hoist up functions. This happens whenever the overload switch on the lift cylinder senses more than normal pressure indicating an overload condition. When overload happens then 12 volts is passed through the overload switch to pull in RELAY A which then interrupts the ground circuit of the valves controlling those**

functions which could cause additional overload. In addition to this, when there is also a signal from the boom down solenoid to RELAY B at the same time, RELAY B latches RELAY A so that even if the overload signal from the pressure switch to RELAY A is removed, RELAY A will continue to be on and interrupt the ground circuit until the signal from the boom down solenoid and pressure switch are removed.

- 2. **The purpose of RELAY A is to interrupt the ground circuit and stop hoist up, boom down, and extend out functions from operating. The purpose of RELAY B is to stop boom bounce caused by the overload system cycling on and off.**

4 OPERATIONAL TEST AND TROUBLE SHOOTING OF RELAY BOX

- A. After the anti-2-block test and the load sensor tests have been performed and the overload system still does not operate, check the relay box.
 - 1. **Disconnect the weatherpak connector in the load sensor pressure switch wires going from the pressure switch to the relay box. Disconnect the weatherpak connector between the cord reel and the relay box.**
 - 2. **Check for 12 volts at pin B of load sensor connector on relay box side of harness. Short from pin A to pin B of weatherpak. When pins A & B are shorted there should NOT be continuity from the cord reel weatherpak on the relay box side of the connection to ground. When A & B are not shorted there should be continuity to ground. Replace relay A if these conditions are not met.**
 - 3. **If the boom tends to bounce when booming down due to intermittent cycling of the overload system, then RELAY B should be replaced after verifying that the sense wire from the relay box to the boom down solenoid valve control terminal is connected.**

OVERLOAD SYSTEM / ANTI-2-BLOCK

TROUBLE SHOOTING GUIDE

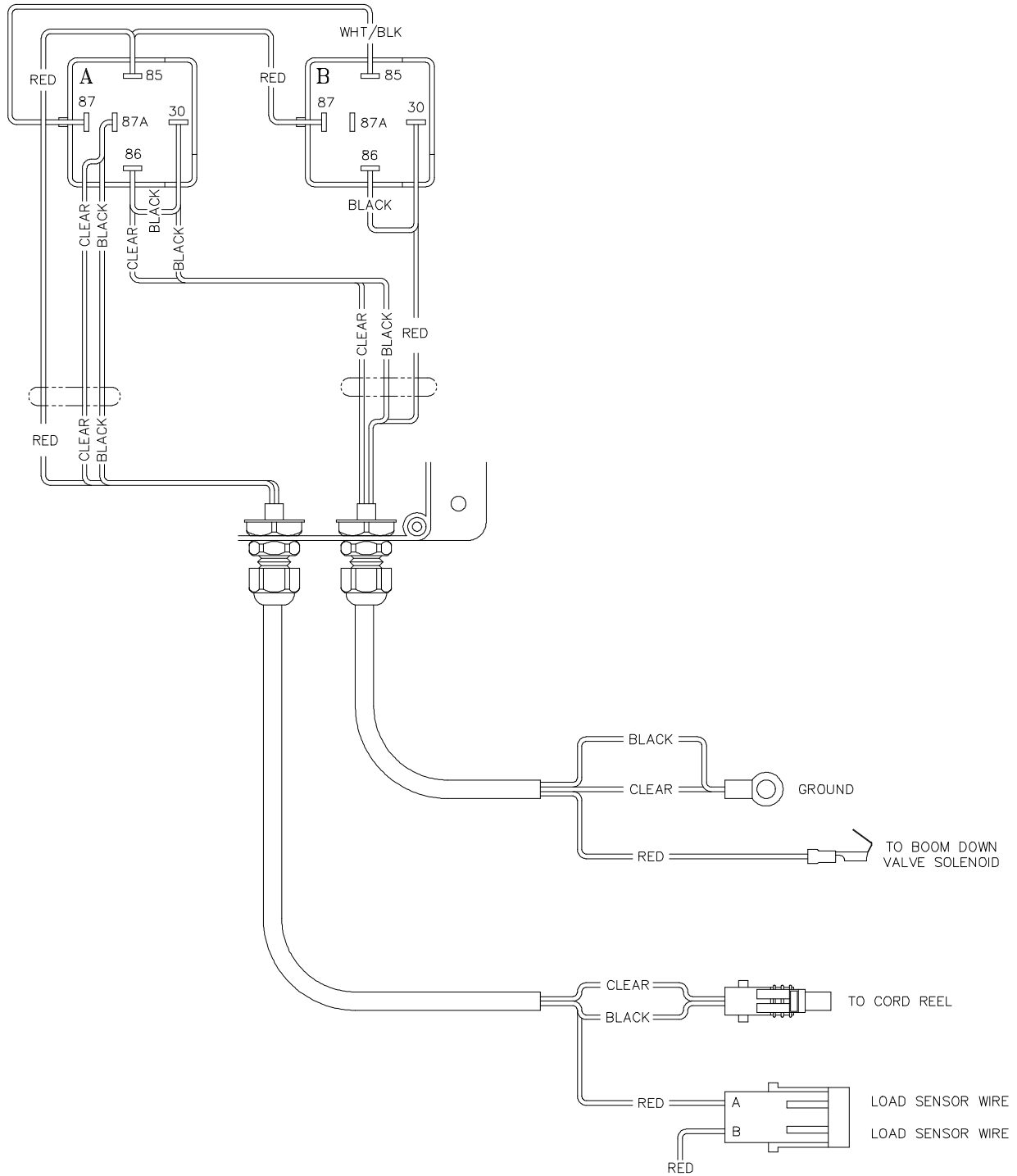

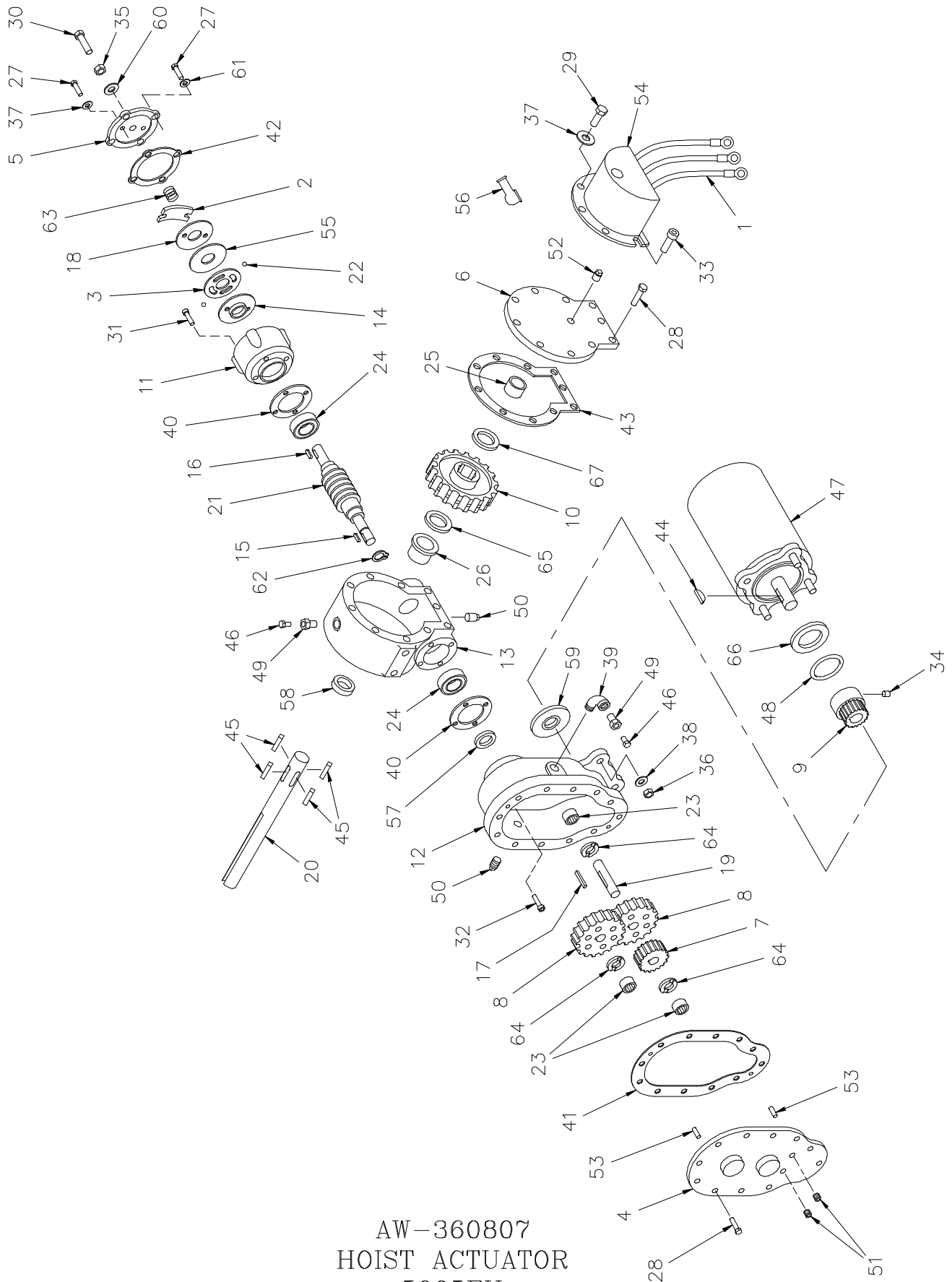

AW-360807
 HOIST ACTUATOR
 5005EH

AW-360807
5005EH HOIST ACTUATOR

ITEM	QTY.	PART NO.	DESCRIPTION
1	1	360467	SOLENOID ASSEMBLY - 12V
2	1	360367	SPRING, FLAT
3	1	360331	PLATE, CAM
4	1	300042	COVER, SPUR GEAR HOUSING
5	1	360450	COVER, BRAKE
6	1	360458	COVER, WORM GEAR HOUSING
7	1	300043	GEAR, IDLER
8	2	300044	GEAR, SPUR
9	1	300046	GEAR, PINION
10	1	360460	GEAR, WORM R.H.
11	1	360336	HOUSING, BRAKE
12	1	300047	HOUSING, SPUR GEAR
13	1	360461	HOUSING, GEAR
14	1	360339	HUB, BRAKE
15	1	300049	KEY, SQ. END
16	1	360341	KEY, RD. END
17	1	300050	KEY, SQ. END
18	1	360342	PLATE, RETAINER
19	1	300053	SHAFT, SPUR
20	1	360556	SHAFT, OUTPUT
21	1	360558	WORM, R.H. 46:1
22	2	360345	BALL
23	3	300056	BEARING, NEEDLE
24	2	300057	BEARING, BALL
25	1	360462	BUSHING, COVER
26	1	360348	BUSHING, HOUSING
27	6	360453	SCREW, 1/4-20NC x 1" LG. HX.HD. Z.P. GR.5 NYLOK HVY. PATCH
28	17	005500	SCREW, 1/4-20NC x 3/4 LG. HX.HD. GR.5
29	3	005604	SCREW, 1/4-20NC x 1" LG. HX.HD. Z.P. GR.5
30	1	360456	SCREW, 3/8-16NC x 1 1/2 LG. HX.HD. GR.5 ALL-THD
31	4	360463	SCREW, 1/4-20NC x 7/8 LG. HX.SOC. BUTTON HD.
32	4	320310	SCREW, 1/4-20NC x 1" LG. SOC.HD. LOC-WEL
33	2	005610	SCREW, 1/4-20NC x 3/4 LG. SOC. HD. Z.P.
34	1	300061	SETSCREW
35	1	360353	NUT, JAM 3/8-16NC
36	3	071012	NUT, 3/8-24NF HEX REG. Z.P.
37	5	360455	WASHER, 1/4 FLAT ALUM.
38	3	021100	LOCKWASHER
39	1	320314	ELBOW, 90°
40	2	300062	GASKET
41	1	300063	GASKET
42	1	360359	GASKET
43	1	360459	GASKET
44	1	360065	KEY, WOODRUFF
45	4	360464	KEY, BARTH
46	2	300066	FITTING, RELIEF
47	1	360807-005	MOTOR, 24V
48	1	300068	O-RING

AW-360807
5005EH HOIST ACTUATOR

ITEM	QTY.	PART NO.	DESCRIPTION
49	2	300069	REDUCER
50	2	360362	PLUG, PIPE SQ.HD.
51	2	320382	PLUG, PIPE SOC.HD.
52	1	300073	PLUG, PIPE SOC.HD.
53	2	300075	PIN
54	1	360468	COVER, SOLENOID
55	1	360364	PLATE, THRUST
56	1	360469	BOOT, RUBBER
57	1	300076	SEAL, OIL
58	1	300077	SEAL, OIL
59	1	300078	SEAL, OIL
60	1	360371	SEAL, THREAD
61	4	360465	SEAL, THREAD
62	1	300079	SNAP RING
63	1	360368	SPRING
64	3	300080	WASHER, THRUST
65	1	300081	WASHER, THRUST
66	1	300082	WASHER, FIBER
67	1	360466	WASHER, THRUST

AUTOMATIC SAFETY BRAKE ASSEMBLY (OIL COOLED) HOIST

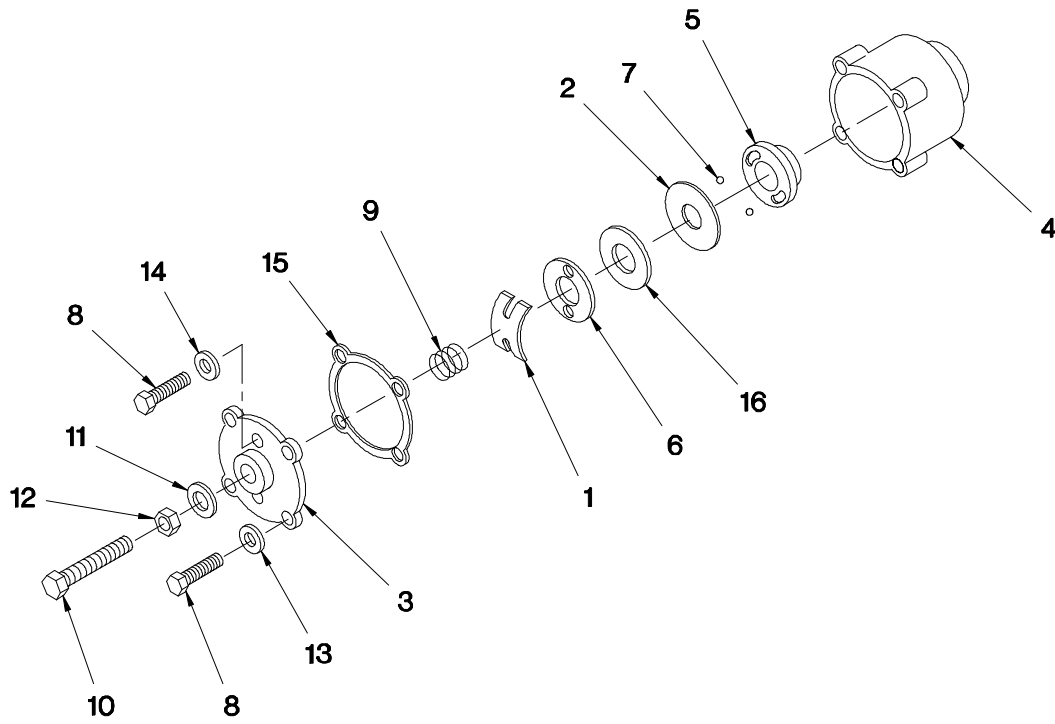

<u>ITEM</u>	<u>QTY</u>	<u>P/N</u>	<u>DESCRIPTION</u>
1	1	360367	FLAT SPRING
2	1	360331	CAM PLATE
3	1	360450	HOUSING COVER
4	1	360336	BRAKE HOUSING
5	1	360339	BRAKE HUB
6	1	360342	RETAINER PLATE
7	2	360345	BRAKE BALL
8	6	360453	CAPSCREW 1/4 NC x 1
9	1	360368	COIL SPRING
10	1	360456	CAPSCREW 3/8 NC x 1 1/2
11	1	360371	THREAD SEAL
12	1	360353	JAM NUT 3/8 NC
13	4	360465	THREAD SEAL
14	2	360455	WASHER FLAT 1/4 ALUM
15	1	360359	GASKET
16	1	360364	THRUST PLATE

AUTOMATIC SAFETY BRAKE ASSEMBLY

(OIL COOLED) HOIST

ASSEMBLY INSTRUCTIONS:

1. Winch has right hand worm and gear. Cable spools over drum. Use number one slots for brake balls(7) in cam plate(2).
2. Install brake hub(5) through brake housing(4) on winch worm with key.
3. Assemble balls(7) in cam plate(2) using hard grease to hold balls in place.
4. Place cam plate(2) on brake hub(5), matching its holes with the balls.
5. Install thrust plate(16).
6. Thread capscrew(10) with jam nut (12) and thread seal (11) through housing cover(3).
7. Place gasket(15) on housing cover(3).
8. Install coil spring(9) on capscrew(10).
9. Install flat spring(1) on capscrew(10).
10. Secure retainer plate(6) and flat spring(1) to housing cover(3) using capscrews(8) and washers(14).
11. Using capscrews(8) and thread seals(13) attach housing cover(3) to brake housing(4).
12. Test brake by shifting winch to UP then DOWN to see if brake is working in proper rotation. If not, remove housing cover(3) and locate brake balls(7) in opposite set of slots of cam plate(2).
13. Adjust to suit by tightening or loosening capscrew(10) on outside of housing cover(3). When proper adjustment is obtained, secure capscrew(10) with jam nut(12).

SOLENOID ASSEMBLY

P/N 360467 - MODEL 5005EH

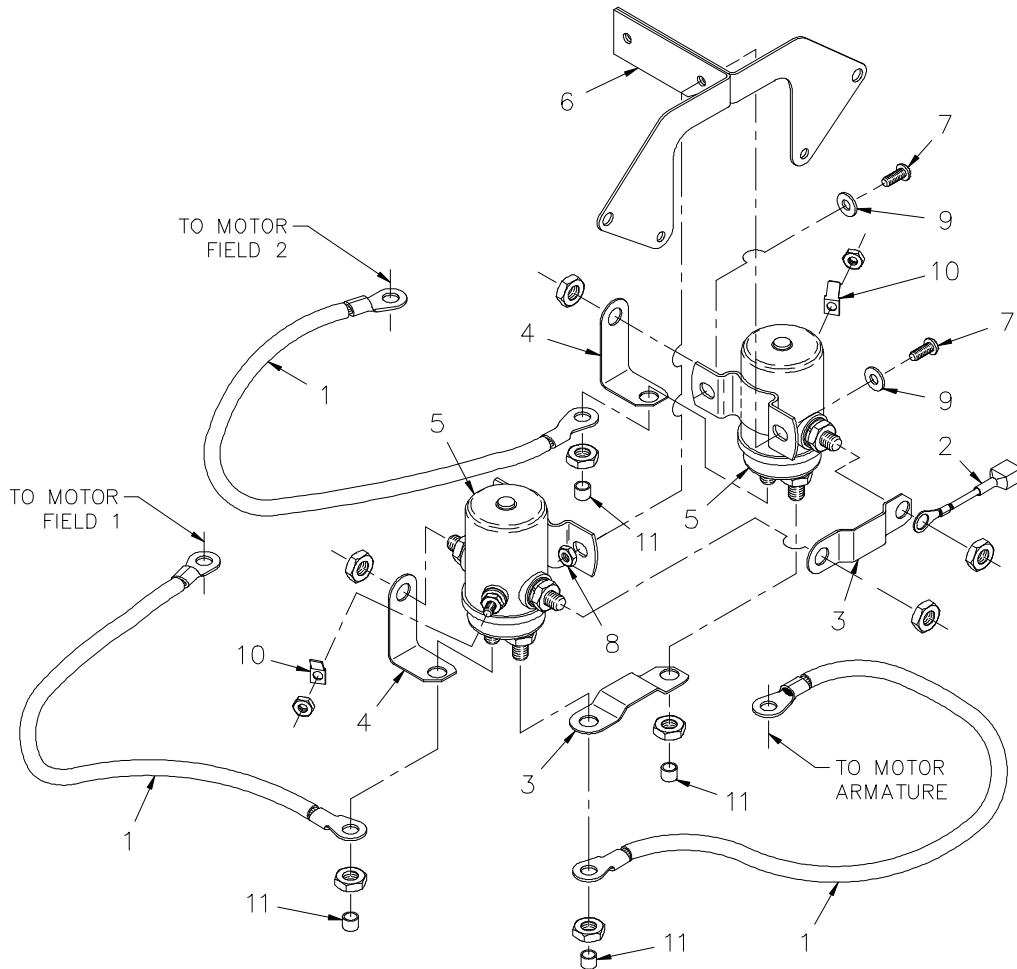

<u>ITEM</u>	<u>QTY</u>	<u>P/N</u>	<u>DESCRIPTION</u>
1	3	360470	BLACK WIRE ASSEMBLY #6 GA x 11 1/2
2	1	360471	RED WIRE ASSEMBLY #16 GA x 1 1/2
3	2	360472	COPPER STRAP
4	2	360473	COPPER STRAP
5	2	200182	12V SOLENOID
6	1	360474	SOLENOID MOUNTING BRACKET
7	2	360475	RD HD SCREW #10 NC x 1/2
8	2	360476	NUT #10 NC
9	2	360477	FLAT WASHER #10
10	2	360478	TERMINAL TAB
11	4	360479	SOLENOID TERMINAL COVER

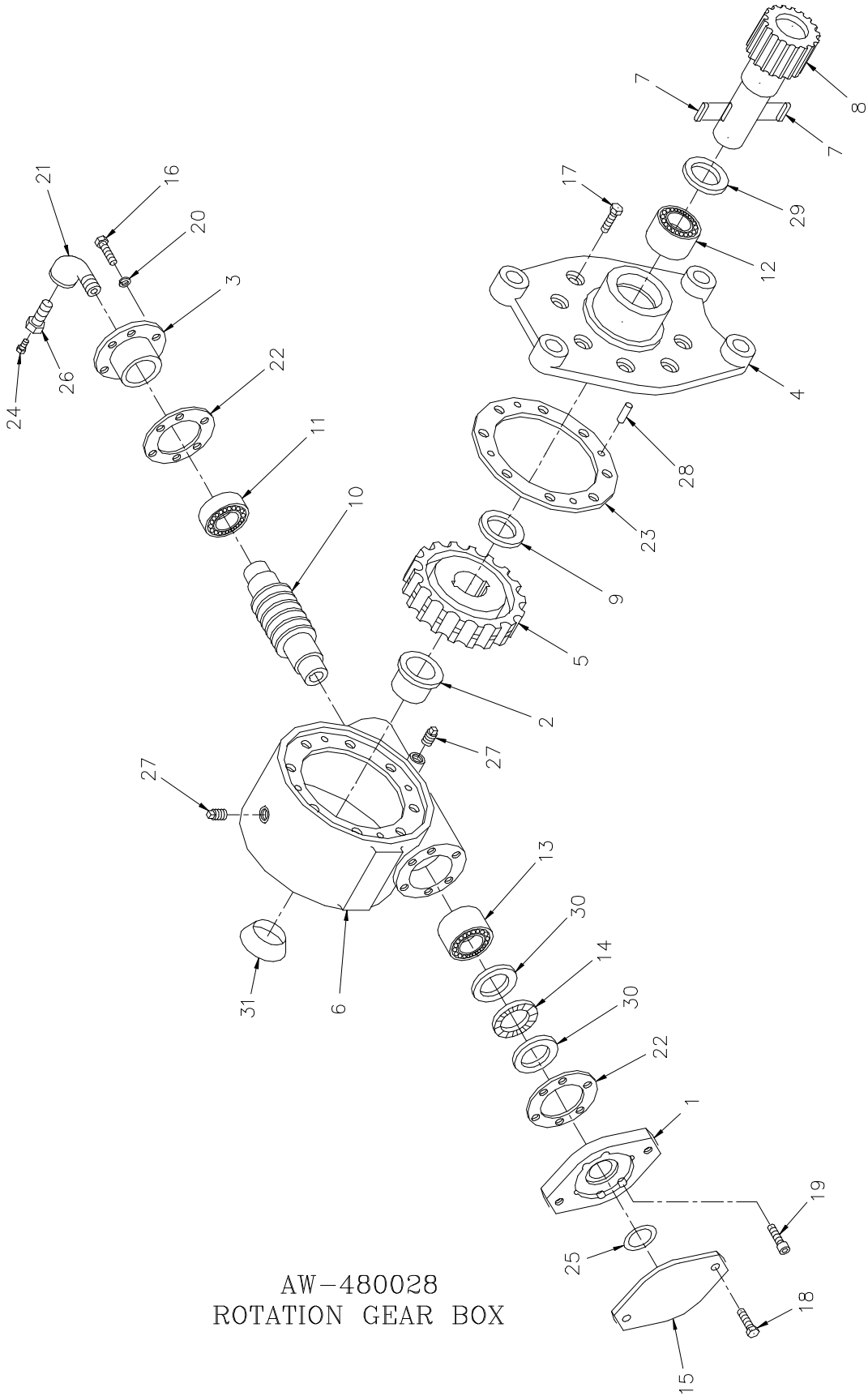

AW-480028
ROTATION GEAR BOX

AW-480028
ROTATION GEAR BOX

AW-480028
ROTATION GEAR BOX

ITEM	QTY.	PART NO.	DESCRIPTION
1	1	480240	ADAPTER
2	1	480241	BUSHING
3	1	480242	CAP, BEARING
4	1	480243	COVER
5	1	480244	GEAR, R.H.
6	1	480237	HOUSING, GEAR
7	2	480246	KEY
8	1	480247	SHAFT, OUTPUT
9	1	480248	WASHER, THRUST
10	1	480249	WORM, R.H.
11	1	480251	BEARING, BALL
12	1	480252	BEARING, NEEDLE
13	1	480253	BEARING, NEEDLE
14	1	480254	BEARING, THRUST
15	1	480255	COVER
16	6	007400	CAPSCREW, 5/16-18NC X 1" LG. HX. HD.
17	8	480238	CAPSCREW, 5/16-18NC X 1 1/4 LG. HX. NYLOC HVY PATCH
18	2	011508	CAPSCREW, 1/2-13NC X 3/4 LG. HX. HD.
19	6	480256	CAPSCREW, 5/16-18NC X 1" LG. SOC. HD. LOC.-WEL
20	6	480258	LOCKWASHER, 5/16 MED. SECT. C.P.
21	1	480259	ELBOW, 90°
22	2	480260	GASKET
23	1	480250	GASKET
24	1	480262	FITTING, RELIEF
25	1	480239	O-RING
26	1	480263	REDUCER
27	2	480264	PLUG, PIPE
28	4	480265	PIN, DOWEL
29	1	480266	SEAL, OIL
30	2	480268	WASHER, THRUST
31	1	480269	PLUG, EXPANSION

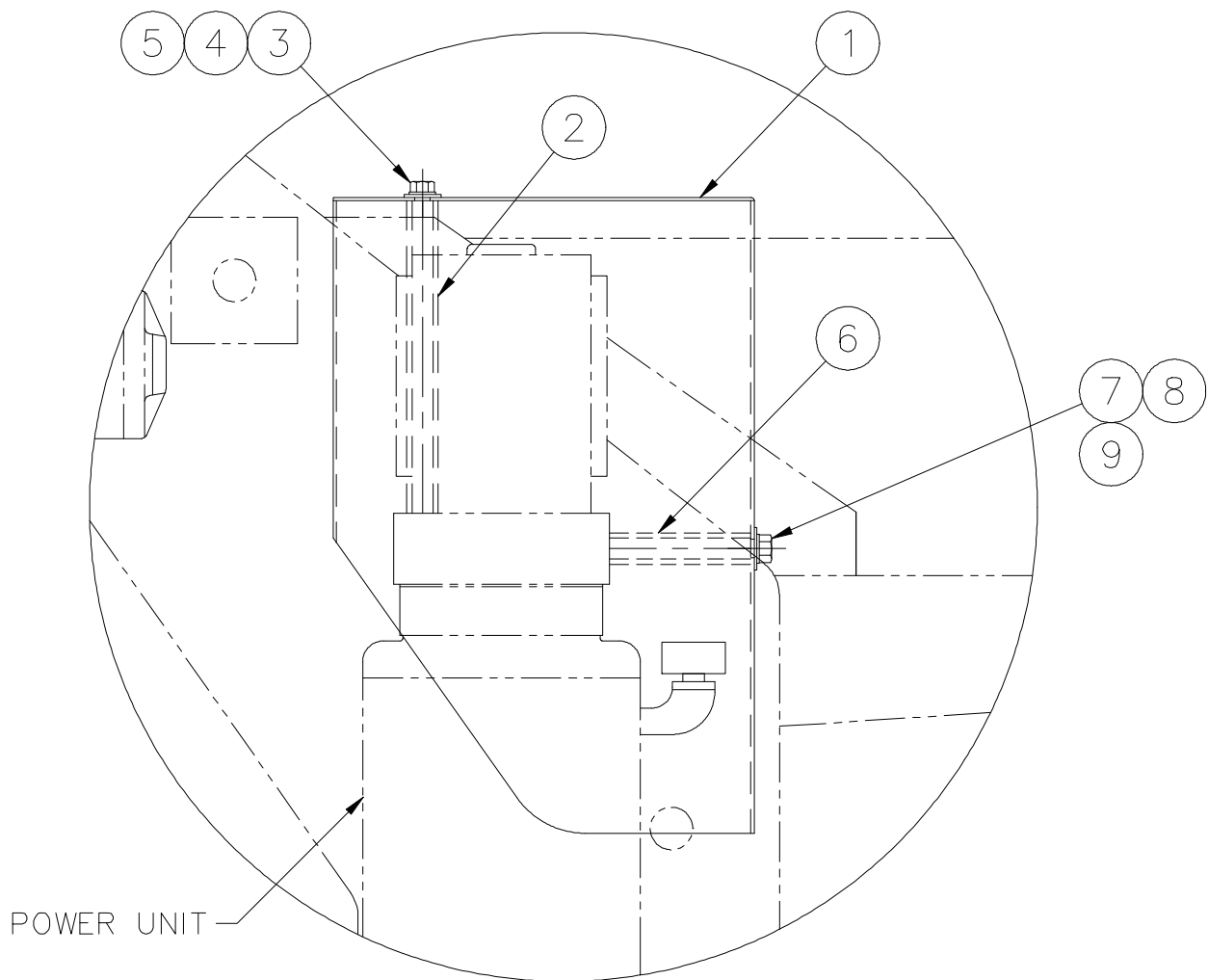

<u>ITEM</u>	<u>QTY</u>	<u>P/N</u>	<u>DESCRIPTION</u>	<u>ITEM</u>	<u>QTY</u>	<u>P/N</u>	<u>DESCRIPTION</u>
1	1	360836	COVER, POWER UNIT	6	2	360855	SPACER, 3 3/8 LG.
2	1	360854	SPACER, 7 7/16 LG.	7	2	811023	SCW, 3/8 x 4 LG.
3	1	007817	SCW, 5/16NC x 8" LG.	8	2	021200	WASHER, FLAT 3/8
4	1	020901	WASHER, FLAT 5/16	9	2	021100	WASHER, SP LK 3/8
5	1	020600	WASHER, SP LK 5/16				

AW-360835
 COVER INSTALLATION
 5005EH POWER UNIT

HYDRAULICS

5005EH

Counterbalance Valve Adjustment

- { With PTO disengaged and boom properly supported, remove O-ring plug (item 17) shown on AW-573 marked "X" port (see CB valve diagram). Install a pressure gauge (0-2500 PSI) into the port.
- { Engage PTO and insure pump flow is 10

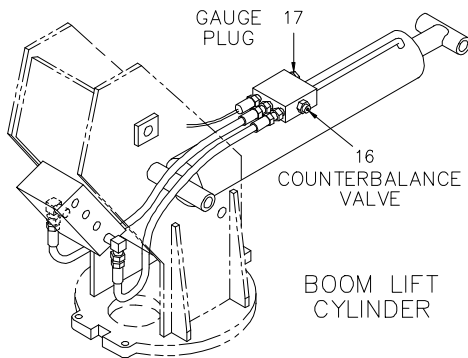

AW-573

GPM and main relief is set to 2500 PSI. With no load on boom, boom up to an angle of 70 degrees. Boom down and note pressure. If pressure reading is not approximately 1050 PSI, the counterbalance valve requires adjustment.

- v To increase the CB valve setting, loosen nut and turn Allen head screw counter clockwise. (Reference item 16, located on the side of the CB valve block towards the right side of the boom.)
- v To reduce the CB valve setting, loosen nut and turn Allen head screw clockwise.

- { Tighten nut on adjustment screw and repeat procedure if needed to obtain the proper pressure setting.
- { Disengage PTO, remove the pressure gauge and install -6 plug. Crane is now ready for operation.

Notice:

- { In an EMERGENCY situation when it becomes necessary to lower the boom without flow present, the CB valve adjustment can be turned in until the boom begins to descend. Make sure the boom will lower onto a proper support. Loosen the lock nut and carefully turn adjustment screw clockwise! Count the number of turns. *Turn slowly until the boom just begins to lower, and remove hand/arm/fingers from cranes while boom is lowering.*
- { Turning adjustment screw too far will cause valve to come apart on the inside. This condition is not repairable
- { After boom is lowered, turn adjustment screw counter clockwise the approximate number of turns made during lowering procedure. After the problem is corrected, readjust the counterbalance valve using the procedure in this manual.

WARNING:
DO NOT TRY TO ADJUST VALVES WHILE BOOM IS MOVING. Failure to heed warning may result in personal injury!

HYDRAULIC ASSEMBLY (10-16-20)

P/N 360803 - MODEL 5005EH

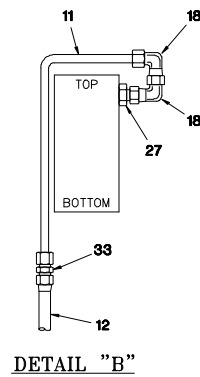
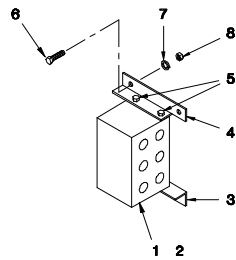
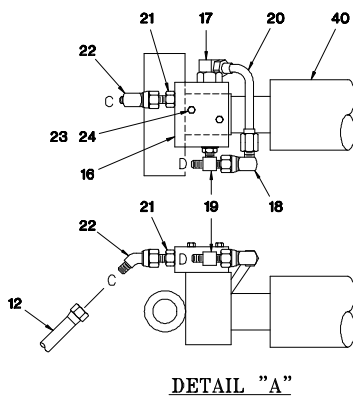
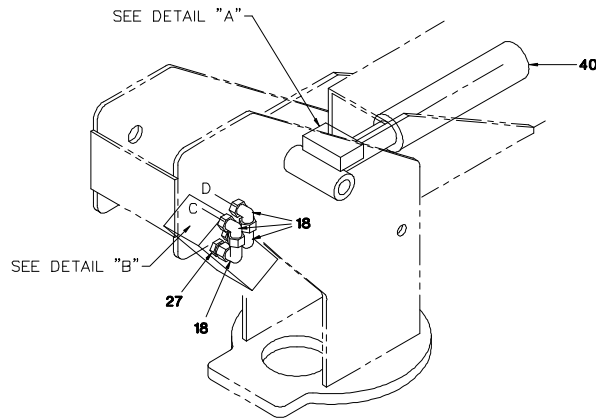
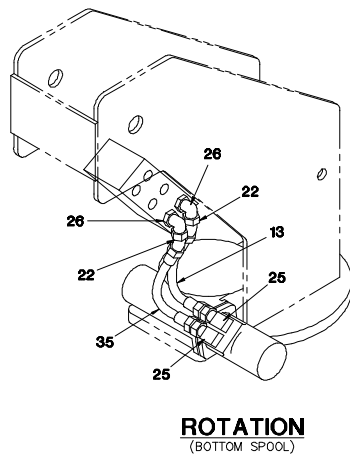
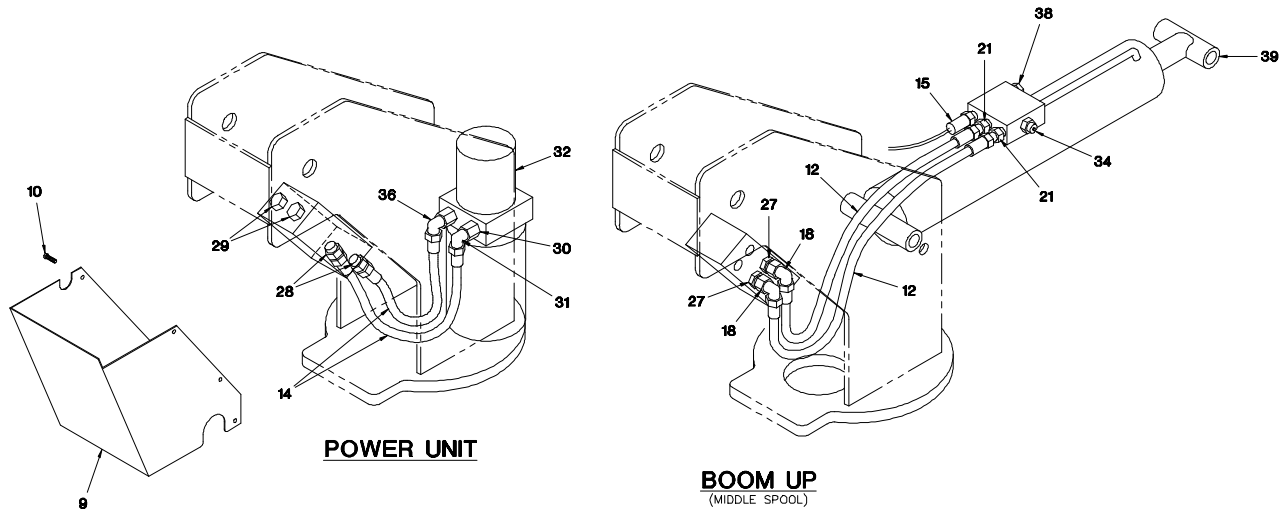

HYDRAULIC ASSEMBLY (10-16-20)

P/N 360803 - MODEL 5005EH

<u>ITEM</u>	<u>QTY</u>	<u>P/N</u>	<u>DESCRIPTION</u>
1	1	202710	MANIFOLD
2	3	REF	DIRECTIONAL VALVE ASSEMBLY (300204)
3	1	320393	BOTTOM MANIFOLD BRACKET
4	1	320392	TOP MANIFOLD BRACKET
5	4	002614	CAPSCREW 5/16-NC x 5/8
6	4	007811	CAPSCREW 5/16-NC x 1
7	4	020600	SPLIT LOCK WASHER 5/16
8	4	016500	HEX HEAD NUT 5/16-NC
9	1	360544	VALVE COVER
10	6	002608	CAPSCREW 1/4-NC x 3/4
11	2	320489	TUBE ASSEMBLY
12	4	480208	HOSE ASSEMBLY
13	1	812203-013	HOSE ASSEMBLY
14	2	360573	HOSE ASSEMBLY
15	1	320543	LOAD SENSOR
16	1	330412	COUNTERBALANCE VALVE
17	1	200892	90° ELBOW -6 NPT/-6 JIC
18	7	480194	90° ELBOW -6 JIC SWIVEL/-6 JIC
19	1	241168	TEE -6 ORB/-6 JIC RUN
20	1	480212	TUBE ASSEMBLY
21	3	200876	ADAPTER -6 ORB/-6 JIC
22	3	330647	45° ELBOW -6 JIC SWIVEL
23	2	005810	CAPSCREW 1/4-NC x 1 3/4
24	2	020200	SPLIT LOCK WASHER 1/4
25	2	202759	90° ELBOW -8 NPT/-6 JIC
26	2	330272	90° ELBOW -8 ORB/-6 JIC
27	4	202756	ADAPTER -8 ORB/-6 JIC
28	2	202755	ADAPTER -10 ORB/-6 JIC
29	2	330072	HEX HEAD PLUG -10 ORB
30	1	320336-002	RETURN PORT PLUG
31	1	241175	90° ELBOW -6 ORB/-6 JIC
32	1	REF	POWER UNIT (360798)
33	2	241170	UNION -6 JIC
34	1	480188	COUNTERBALANCE VALVE CARTRIDGE
35	1	812203-014	HOSE ASSEMBLY

HYDRAULIC ASSEMBLY (10-16-20)

P/N 360803 - MODEL 5005EH

<u>ITEM</u>	<u>QTY</u>	<u>P/N</u>	<u>DESCRIPTION</u>
36	1	330645	90° EXTRA LONG ELBOW -6 ORB/-6 JIC
37	-	-	-
38	1	REF	PLUG -6 O-RING
39	1	REF	BOOM UP CYLINDER (360805)
40	1	REF	EXTENSION CYLINDER (366162)

HYDRAULIC ASSEMBLY (10-16)

P/N 360866 - MODEL 5005EH

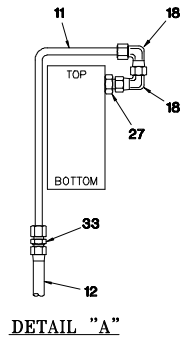
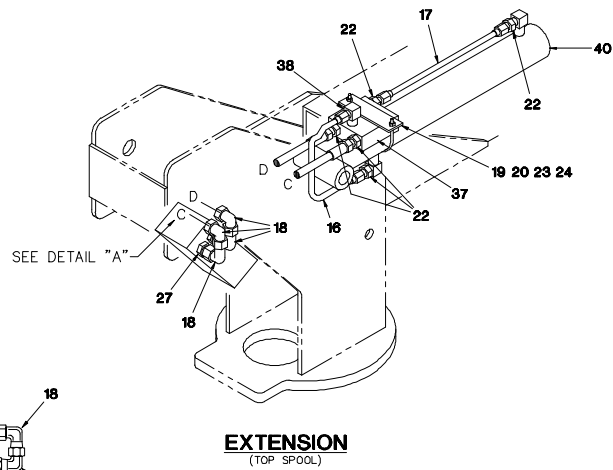
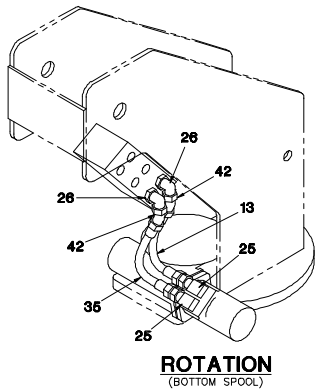
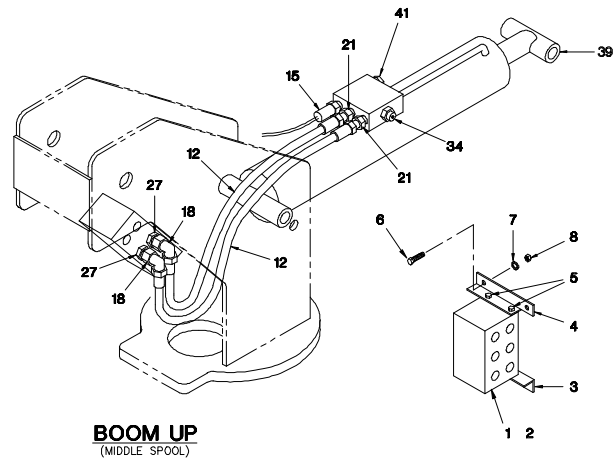
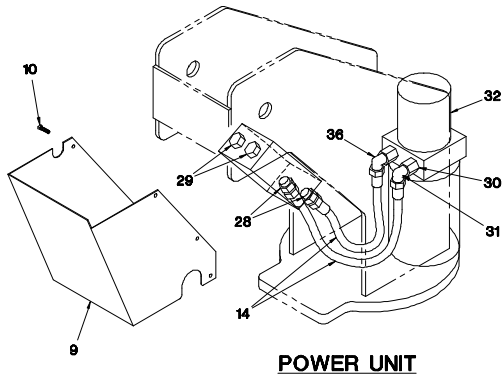

HYDRAULIC ASSEMBLY (10-16)

P/N 360866 - MODEL 5005EH

<u>ITEM</u>	<u>QTY</u>	<u>P/N</u>	<u>DESCRIPTION</u>
1	1	202710	MANIFOLD
2	3	REF	DIRECTIONAL VALVE ASSEMBLY (300204)
3	1	320393	BOTTOM MANIFOLD BRACKET
4	1	320392	TOP MANIFOLD BRACKET
5	4	002614	CAPSCREW 5/16-NC x 5/8
6	4	007811	CAPSCREW 5/16-NC x 1
7	4	020600	SPLIT LOCK WASHER 5/16
8	4	016500	HEX HEAD NUT 5/16-NC
9	1	360544	VALVE COVER
10	6	002608	CAPSCREW 1/4-NC x 3/4
11	2	320489	TUBE ASSEMBLY
12	4	480208	HOSE ASSEMBLY
13	1	812203-013	HOSE ASSEMBLY
14	2	360573	HOSE ASSEMBLY
15	1	320543	LOAD SENSOR
16	1	360069	TUBE ASSEMBLY
17	1	360070	TUBE ASSEMBLY
18	6	480194	90° ELBOW -6 JIC SWIVEL/-6 JIC
19	1	360091	U-BOLT
20	1	360092	CLAMP
21	2	200876	ADAPTER -6 ORB/-6 JIC
22	5	360042	ADAPTER -6 NPT/-6 JIC
23	2	015900	HEX HEAD NUT 1/4-NC
24	2	020200	SPLIT LOCK WASHER 1/4
25	2	202759	90° ELBOW -8 NPT/-6 JIC
26	2	330272	90° ELBOW -8 ORB/-6 JIC
27	4	202756	ADAPTER -8 ORB/-6 JIC
28	2	202755	ADAPTER -10 ORB/-6 JIC
29	2	330072	HEX HEAD PLUG -10 ORB
30	1	320336-002	RETURN PORT PLUG
31	1	241175	90° ELBOW -6 ORB/-6 JIC
32	1	REF	POWER UNIT (360798)
33	2	241170	UNION -6 JIC
34	1	480188	COUNTERBALANCE VALVE CARTRIDGE
35	1	812203-014	HOSE ASSEMBLY

HYDRAULIC ASSEMBLY (10-16)

P/N 360866 - MODEL 5005EH

<u>ITEM</u>	<u>QTY</u>	<u>P/N</u>	<u>DESCRIPTION</u>
36	1	330645	90° EXTRA LONG ELBOW -6 ORB/-6 JIC
37	1	360153	COUNTERBALANCE VALVE
38	1	200892	90° ELBOW -6 NPT/-6 JIC
39	1	REF	BOOM UP CYLINDER (360805)
40	1	REF	EXTENSION CYLINDER (360152)
41	1	REF	PLUG -6 O-RING
42	2	330647	45° ELBOW -6 JIC SWIVEL

HYDRAULIC PUMP & RESERVOIR

P/N 360798

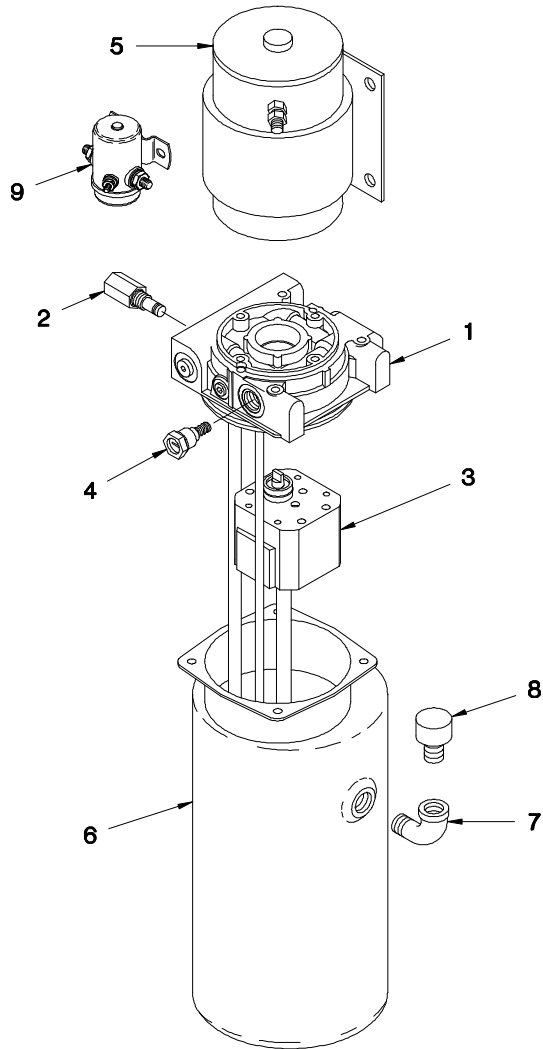

<u>ITEM</u>	<u>QTY</u>	<u>P/N</u>	<u>DESCRIPTION</u>
1	1	360808-003	ADAPTER KIT
2	1	320336-002	RETURN PORT PLUG KIT
3	1	360808-001	PUMP KIT
4	1	320336-003	RELIEF VALVE KIT
5	1	360808-002	MOTOR
6	1	360799	RESERVOIR KIT
7	1	320335-008	ELBOW FITTING
8	1	200545	BREATHER CAP
9	1	330630	SOLENOID

(BB) NEXT PAGE

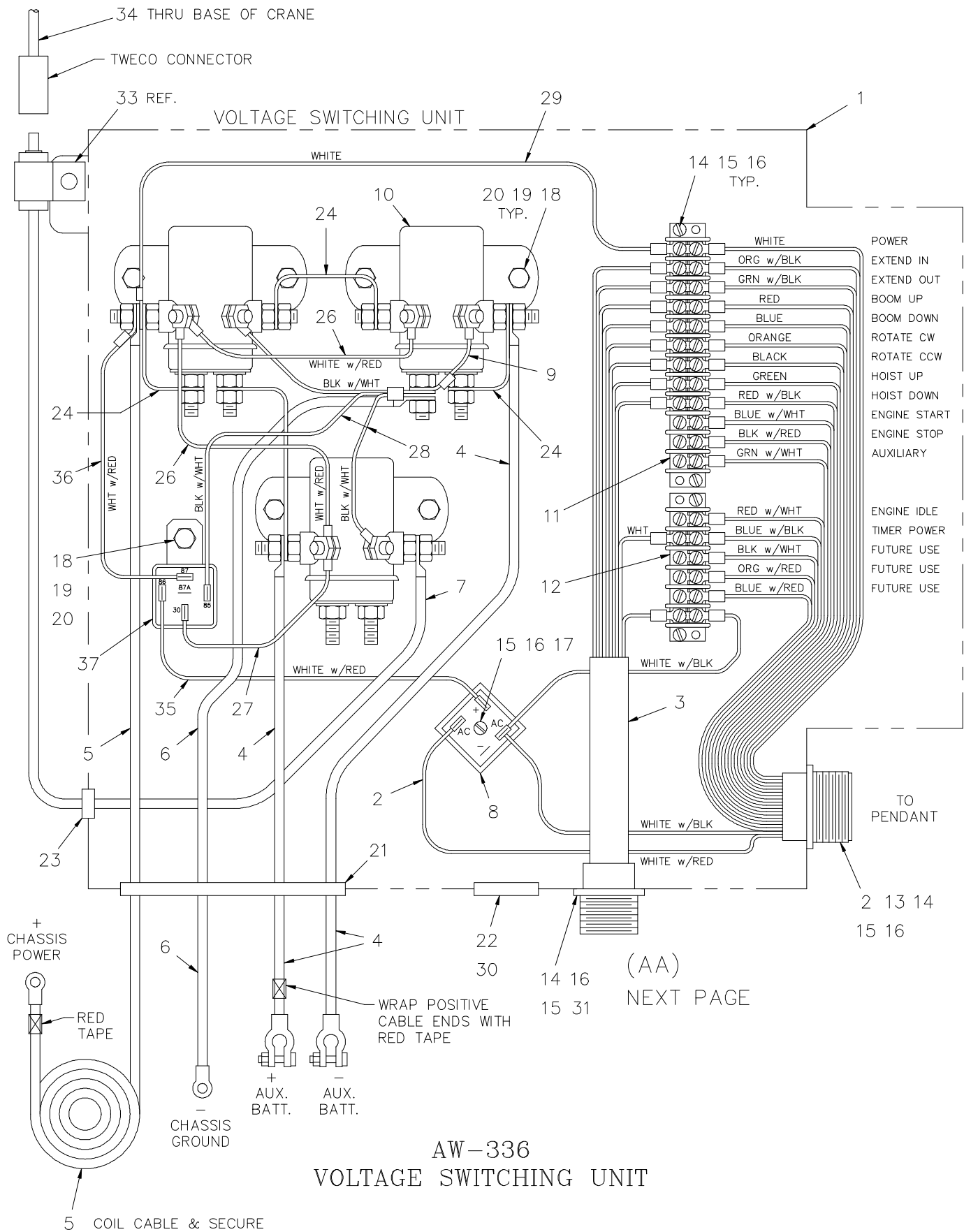

(AA)
NEXT PAGE

AW-336 VOLTAGE SWITCHING UNIT

AW-336, VOLTAGE SWITCHING UNIT

ITEM	QTY.	PART NO.	DESCRIPTION
1	1	360832	ENCLOSURE ASSEMBLY
2	1	680081	RECEPTACLE ASSEMBLY
3	1	360834	POWER CABLE, RECEPTACLE ASSY
4	2	360853	BATTERY CABLE
5	1	360858	CONDUCTOR ASSEMBLY (25'-9")
6	1	360859	CONDUCTOR ASSEMBLY (6'-9")
7	1	360844-002	CONDUCTOR ASSEMBLY (w/ MALE TWECO)
8	1	751138	RECTIFIER, BRIDGE 25 AMP
9	1	360845	CONDUCTOR ASSEMBLY
10	3	200182	RELAY
11	1	635200	TERMINAL BLOCK, 12 STATION
12	1	635203	TERMINAL BLOCK, 6 STATION
13	1	480547	CAP, RECEPTACLE
14	8	000404	SCREW, #6-32NC x 5/8 LG.
15	9	015400	NUT, HEX #6-32NC
16	9	019600	WASHER, SP LK #6
17	1	000602	SCREW, #6-32NC x 1 LG.
18	6	005901	SCREW, HEX HD 1/4-20NC x 1/2 LG.
19	6	015900	NUT, HEX 1/4-20NC
20	6	020200	WASHER, SP LK 1/4
21	1	750282	GROMMET
22	1	371024	GROMMET
23	1	750169	GROMMET
24	4	658300	CONDUCTOR ASSEMBLY (COPPER STRIP)
25	2	360872	CONDUCTOR ASSEMBLY
26	2	360873	CONDUCTOR ASSEMBLY
27	1	360841	CONDUCTOR ASSEMBLY
28	1	360876	CONDUCTOR ASSEMBLY
29	1	360877	CONDUCTOR ASSEMBLY
30	1	360878	CAP PLUG, TAPERED
31	1	360879	CAP PLUG (10 PIN RECEPTACLE)
32	1	360837	DECAL, V.S.U. WIRING DIAGRAM
33	1	480024	MOUNT, CABLE RETAINER
34	1	360844-001	CONDUCTOR ASSEMBLY (w/ FEMALE TWECO)
35	1	360868	CONDUCTOR ASSEMBLY
36	1	360871	CONDUCTOR ASSEMBLY
37	1	320355	RELAY, DROP OUT

ELECTRICAL SCHEMATIC

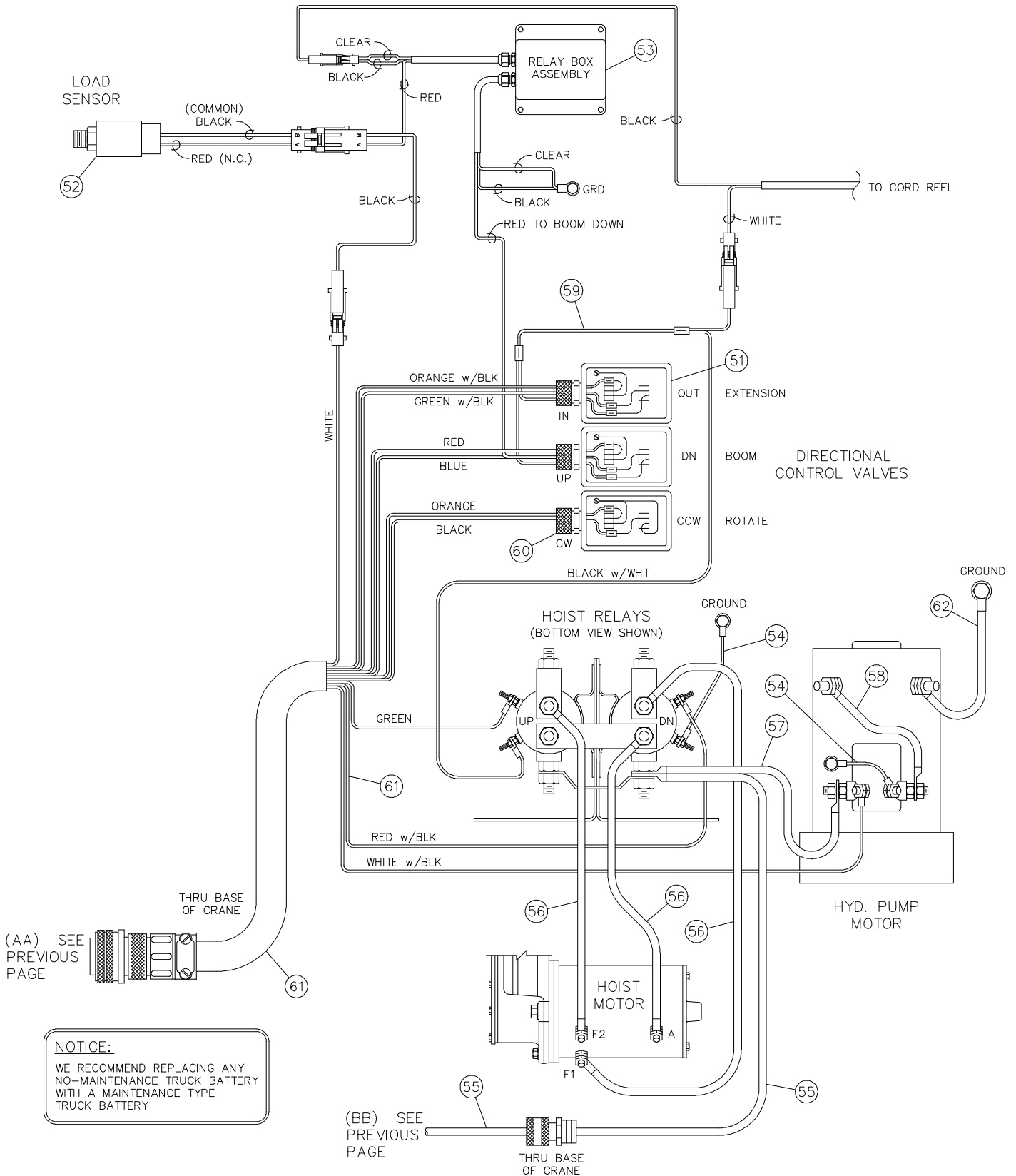

ELECTRICAL SCHEMATIC

<u>ITEM</u>	<u>QTY</u>	<u>P/N</u>	<u>DESCRIPTION</u>
50	1	REFERENCE	VOLTAGE SWITCHING UNIT (360802-001)
51	3	300204	DIRECTIONAL CONTROL VALVE
52	1	320543	LOAD SENSOR ASSEMBLY
53	1	366999	RELAY BOX ASSEMBLY
54	2	360872	CONDUCTOR ASSEMBLY
55	1	360844-001	CONDUCTOR ASSEMBLY (WITH FEMALE TWECO)
56	3		CONDUCTOR ASSEMBLY (SUPPLIED WITH HOIST)
57	1	360011	CONDUCTOR ASSEMBLY
58	1		CONDUCTOR ASSEMBLY (SUPPLIED WITH POWER UNIT)
59	1	360846	CONDUCTOR ASSEMBLY
60	3	642908	CONDUCTOR CORD
61	1	360857	POWER CABLE PLUG ASSEMBLY
62	1	360843	CONDUCTOR ASSEMBLY
63	6 FT	750736	CONVOLUTED LOOM
64	1	360844-002	CONDUCTOR ASSEMBLY (WITH MALE TWECO)

PENDANT

P/N 680050

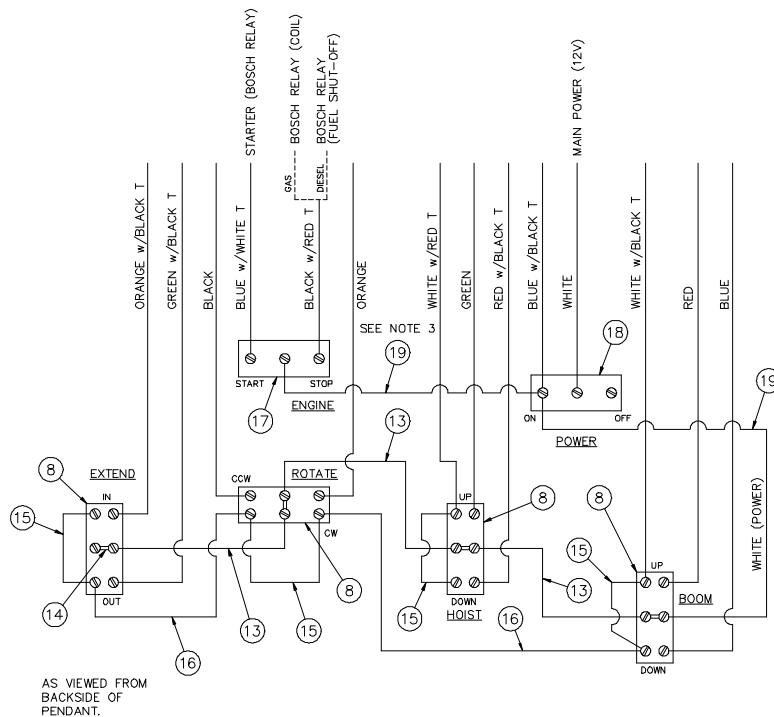
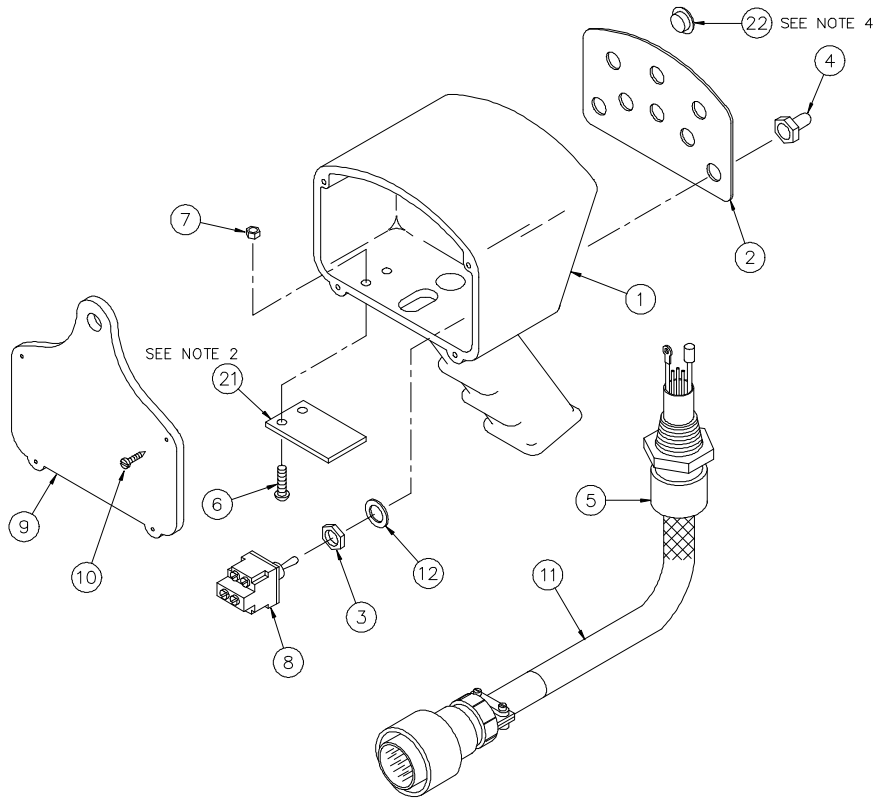

PENDANT

P/N 680050

<u>ITEM</u>	<u>QTY</u>	<u>P/N</u>	<u>DESCRIPTION</u>
1	1	-	PENDANT HOUSING
2	1	-	DECAL/COVER PLATE
3	6	-	NUT
4	6	-	TOGGLE BOOT
5	1	480567	HUBBELL CONNECTOR CORD GRIP
6	2	-	CAPSCREW #10-24 NC x 3/4
7	2	-	HEX LOCK NUT #10-24 NC
8	4	-	TOGGLE DPDT SWITCH
9	1	-	HOUSING BACK PLATE
10	4	-	SELF THREADING ROUND HEAD SCREW #6 x 3/4
11	1	680041	BAYONET CABLE ASSEMBLY
12	6	-	LOCK WASHER
13	3	660302	CONDUCTOR ASSEMBLY
14	4	636600	JUMPER
15	4	622346	CONDUCTOR ASSEMBLY
16	2	622347	CONDUCTOR ASSEMBLY
17	1	-	TOGGLE SPDT SWITCH
18	1	-	TOGGLE ON/OFF SWITCH
19	1	480526	CONDUCTOR ASSEMBLY
20	2	750737	CABLE TIE
21	1	-	TRIGGER OPENING COVER
22	2	-	PLASTIC 1/2" PLUG (<i>see note 4</i>)

NOTES:

1. Tie-off the following unused conductors with Item #20 inside of pendnat.
Blue w/ Red T Orange w/ Red T Black w/ White T
2. Before installing Item #21 (Cover), add RTV Sealant between cover & Pendant Housing.
3. Securely wrap unused power connector terminals (Ref. Item #19) with electrical tape; terminals must be unwrapped when adding switches for options.
4. Item #22 (Plastic Plugs) are to be installed in any unused holes in Cover Plate Item #2.
5. Items 3, 4, 8, & 12 may be purchased as a **REPLACEMENT DPDT SWITCH KIT** using **P/N 380005**.
6. Items 3, 4, 12, & 18 may be purchased as a **REPLACEMENT ON/OFF SWITCH KIT** using **P/N 380001**.
7. Items 1, 2, 6, 7, 9, 10, 21, & 22 may be purchased as a **REPLACEMENT HOUSING KIT** using **P/N 380002**.
8. Items 3, 4, 12, & 17 may be purchased as a **REPLACEMENT SPDT KIT** using **P/N 380004**.

PENDANT

P/N 680008

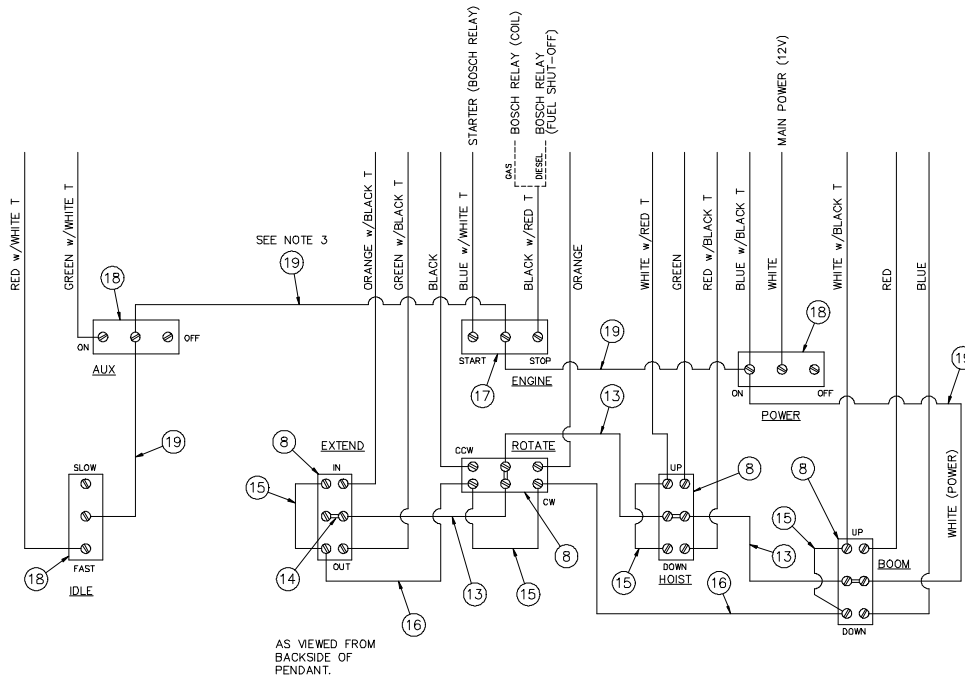
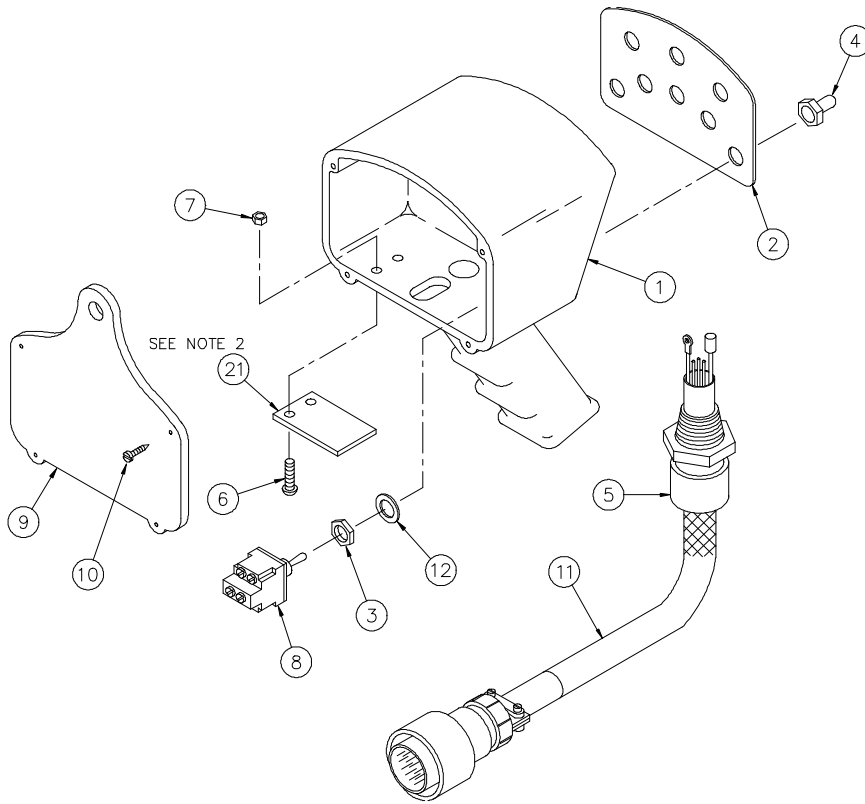

PENDANT

P/N 680008

<u>ITEM</u>	<u>QTY</u>	<u>P/N</u>	<u>DESCRIPTION</u>
1	1	-	PENDANT HOUSING
2	1	-	DECAL/COVER PLATE
3	6	-	NUT
4	8	-	TOGGLE BOOT
5	1	480567	HUBBELL CONNECTOR CORD GRIP
6	2	-	CAPSCREW #10-24 NC x 3/4
7	2	-	HEX LOCK NUT #10-24 NC
8	4	-	TOGGLE DPDT SWITCH
9	1	-	HOUSING BACK PLATE
10	4	-	SELF THREADING ROUND HEAD SCREW #6 x 3/4
11	1	680041	BAYONET CABLE ASSEMBLY
12	6	-	LOCK WASHER
13	3	660302	CONDUCTOR ASSEMBLY
14	4	636600	JUMPER
15	4	622346	CONDUCTOR ASSEMBLY
16	2	622347	CONDUCTOR ASSEMBLY
17	1	-	TOGGLE SPDT SWITCH
18	3	-	TOGGLE ON/OFF SWITCH
19	1	480526	CONDUCTOR ASSEMBLY
20	2	750737	CABLE TIE
21	1	-	TRIGGER OPENING COVER

NOTES:

1. Tie-off the following unused conductors with Item #20 inside of pendant.
Blue w/ Red T Orange w/ Red T Black w/ White T
2. Before installing Item #21 (Cover), add RTV Sealant between cover & Pendant Housing.
3. Securely wrap unused power connector terminals (Ref. Item #19) with electrical tape; terminals must be unwrapped when adding switches for options.
4. Items 3, 4, 8, & 12 may be purchased as a **REPLACEMENT DPDT SWITCH KIT** using **P/N 380005**.
5. Items 3, 4, 12, & 18 may be purchased as a **REPLACEMENT ON/OFF SWITCH KIT** using **P/N 380001**.
6. Items 1, 2, 6, 7, 9, 10, & 21 may be purchased as a **REPLACEMENT HOUSING KIT** using **P/N 380002**.
7. Items 3, 4, 12, & 17 may be purchased as a **REPLACEMENT SPDT KIT** using **P/N 380004**.

PENDANT

P/N 680009

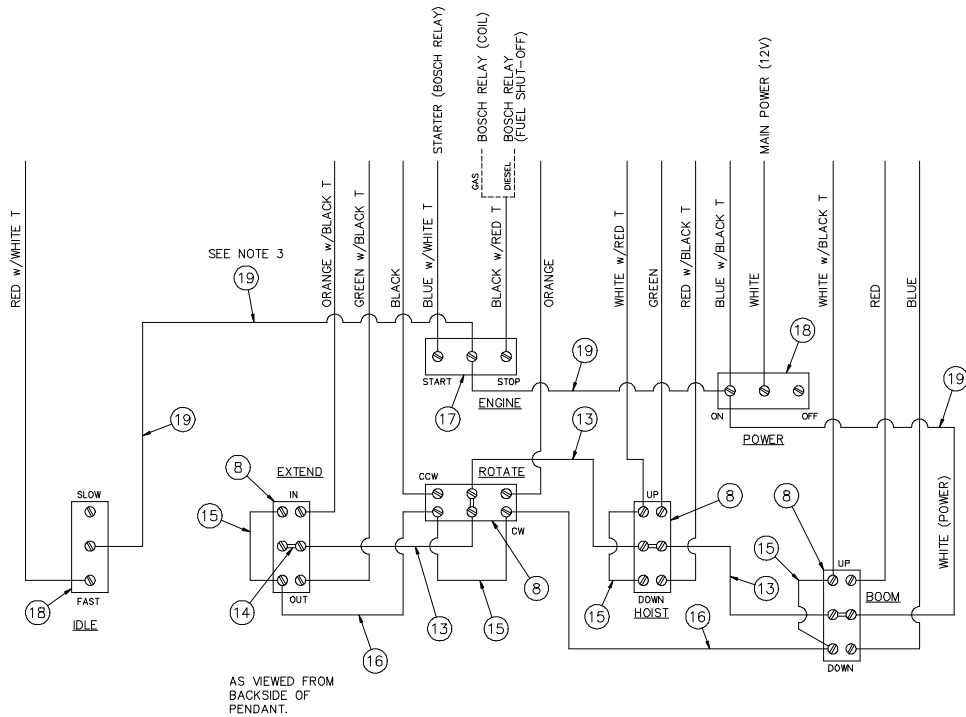
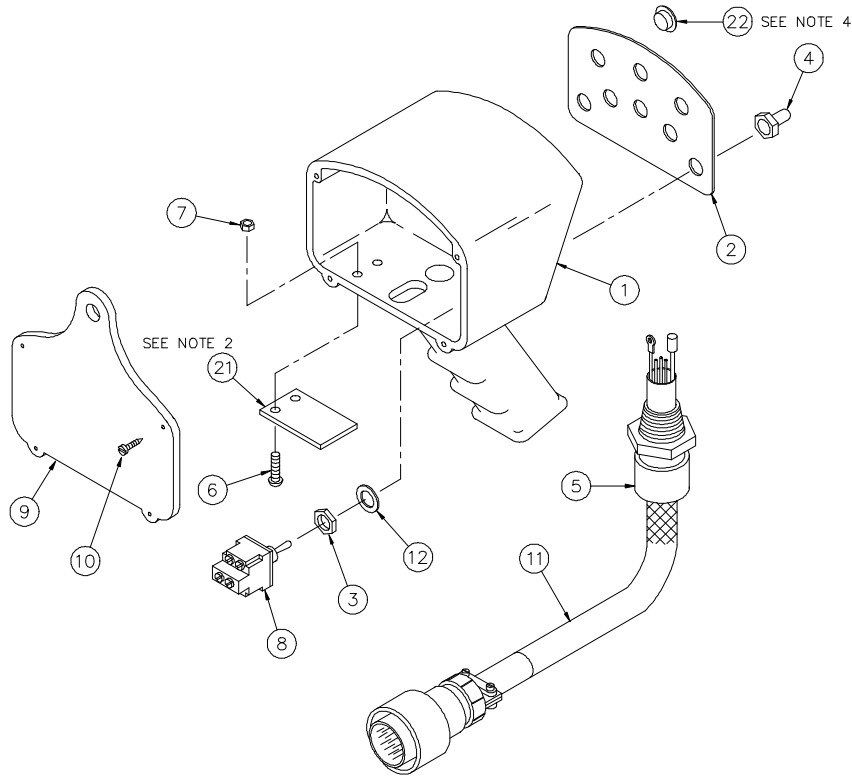

PENDANT

P/N 680009

<u>ITEM</u>	<u>QTY</u>	<u>P/N</u>	<u>DESCRIPTION</u>
1	1	-	PENDANT HOUSING
2	1	-	DECAL/COVER PLATE
3	6	-	NUT
4	6	-	TOGGLE BOOT
5	1	480567	HUBBELL CONNECTOR CORD GRIP
6	2	-	CAPSCREW #10-24 NC x 3/4
7	2	-	HEX LOCK NUT #10-24 NC
8	4	-	TOGGLE DPDT SWITCH
9	1	-	HOUSING BACK PLATE
10	4	-	SELF THREADING ROUND HEAD SCREW #6 x 3/4
11	1	680041	BAYONET CABLE ASSEMBLY
12	6	-	LOCK WASHER
13	3	660302	CONDUCTOR ASSEMBLY
14	4	636600	JUMPER
15	4	622346	CONDUCTOR ASSEMBLY
16	2	622347	CONDUCTOR ASSEMBLY
17	1	-	TOGGLE SPDT SWITCH
18	1	-	TOGGLE ON/OFF SWITCH
19	1	480526	CONDUCTOR ASSEMBLY
20	2	750737	CABLE TIE
21	1	-	TRIGGER OPENING COVER
22	3	-	PLASTIC 1/2" PLUG (see note 4)

NOTES:

1. Tie-off the following unused conductors with Item #20 inside of pendant.
Blue with Red T Orange with Red T Black with White T
2. Before installing Item #21 (Cover), add RTV Sealant between cover & Pendant Housing.
3. Securely wrap unused power connector terminals (Ref. Item #19) with electrical tape; terminals must be unwrapped when adding switches for options.
4. Item #22 (Plastic Plugs) are to be installed in any unused holes in Cover Plate Item #2.
5. Items 3, 4, 8, & 12 may be purchased as a **REPLACEMENT DPDT SWITCH KIT** using P/N **380005**.
6. Items 3, 4, 12, & 18 may be purchased as a **REPLACEMENT ON/OFF SWITCH KIT** using P/N **380001**.
7. Items 1, 2, 6, 7, 9, 10, 21, & 22 may be purchased as a **REPLACEMENT HOUSING KIT** using P/N **380002**.
8. Items 3, 4, 12, & 17 may be purchased as a **REPLACEMENT SPDT KIT** using P/N **380004**.

PENDANT

P/N 680010

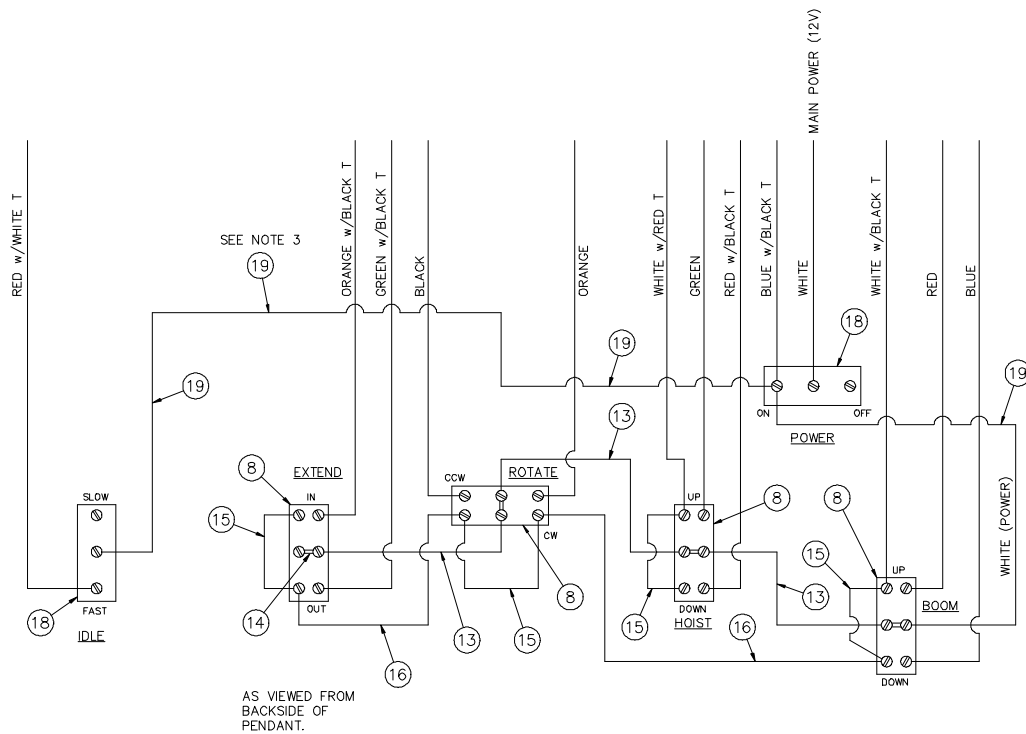
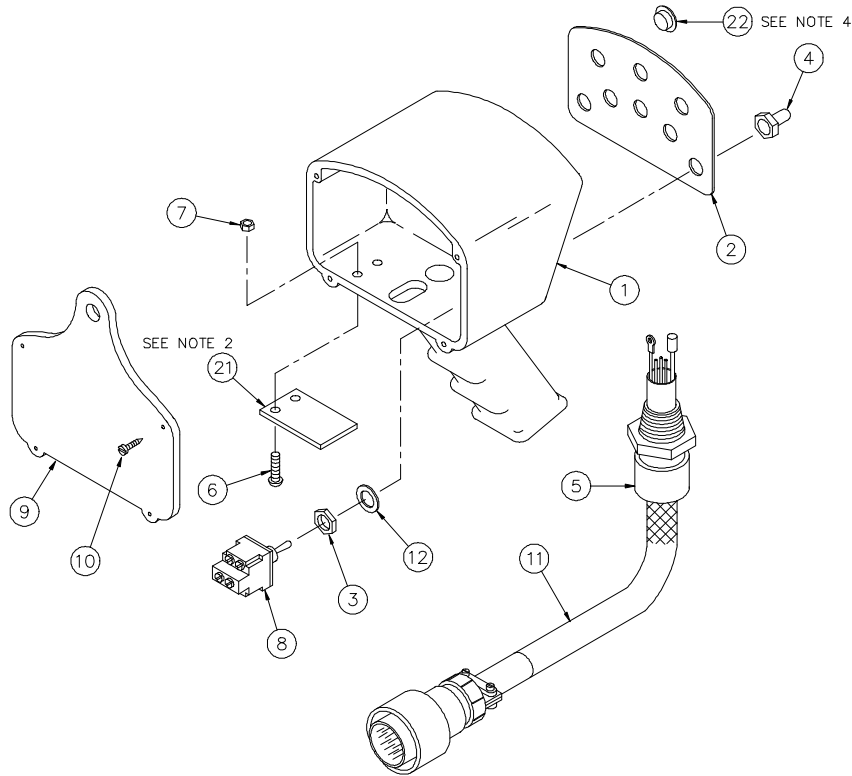

PENDANT

P/N 680010

<u>ITEM</u>	<u>QTY</u>	<u>P/N</u>	<u>DESCRIPTION</u>
1	1	-	PENDANT HOUSING
2	1	-	DECAL/COVER PLATE
3	6	-	NUT
4	6	-	TOGGLE BOOT
5	1	480567	HUBBELL CONNECTOR CORD GRIP
6	2	-	CAPSCREW #10-24 NC x 3/4
7	2	-	HEX LOCK NUT #10-24 NC
8	4	-	TOGGLE SWITCH DPDT
9	1	-	HOUSING BACK PLATE
10	4	-	SELF THREADING ROUND HEAD SCREW #6 x 3/4
11	1	680041	BAYONET CABLE ASSEMBLY
12	6	-	LOCK WASHER
13	3	660302	CONDUCTOR ASSEMBLY
14	4	636600	JUMPER
15	4	622346	CONDUCTOR ASSEMBLY
16	2	622347	CONDUCTOR ASSEMBLY
17	-	-	-
18	1	-	TOGGLE ON/OFF SWITCH
19	1	480526	CONDUCTOR ASSEMBLY
20	2	750737	CABLE TIE
21	1	-	TRIGGER OPENING COVER
22	3	-	PLASTIC 1/2" PLUG <i>(see note 4)</i>

NOTES:

1. Before installing Item 21 (Cover), add RTV Sealant between cover & Pendant Housing.
2. Securely wrap unused power connector terminals (Ref. Item #19) with electrical tape; terminals must be unwrapped when adding switches for options.
3. Item #22 (Plastic Plugs) are to be installed in any unused holes in Cover Plate Item #2.
4. Items 3, 4, 8, & 12 may be purchased as a **REPLACEMENT DPDT SWITCH KIT** using **P/N380005**.
5. Items 3, 4, 12, & 18 may be purchased as a **REPLACEMENT ON/OFF SWITCH KIT** using **P/N380001**.
6. Items 1, 2, 6, 7, 9, 10, 21, & 22 may be purchased as a **REPLACEMENT HOUSING KIT** using **P/N 380002**.

PENDANT

P/N 680021

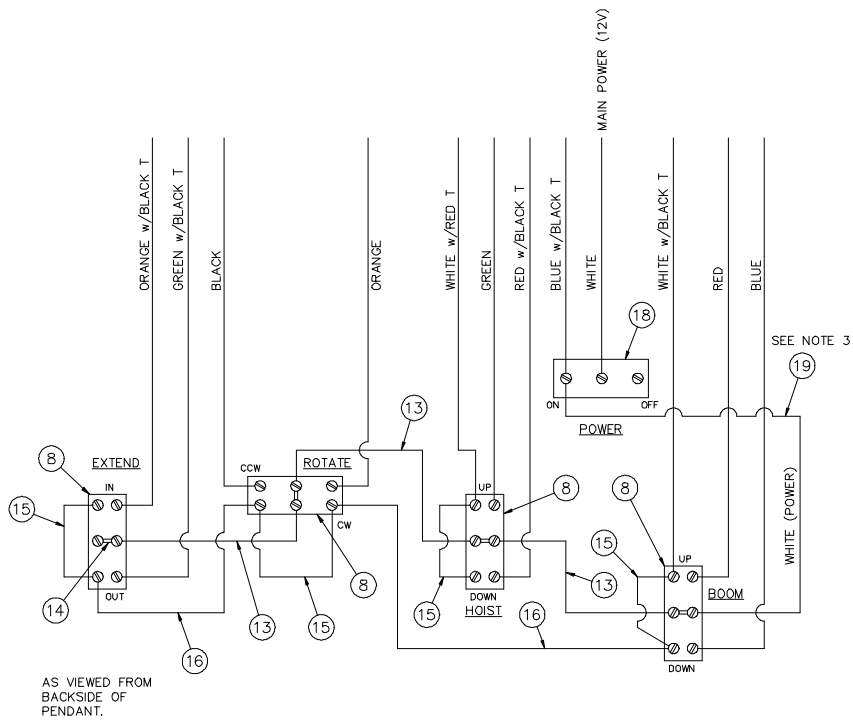
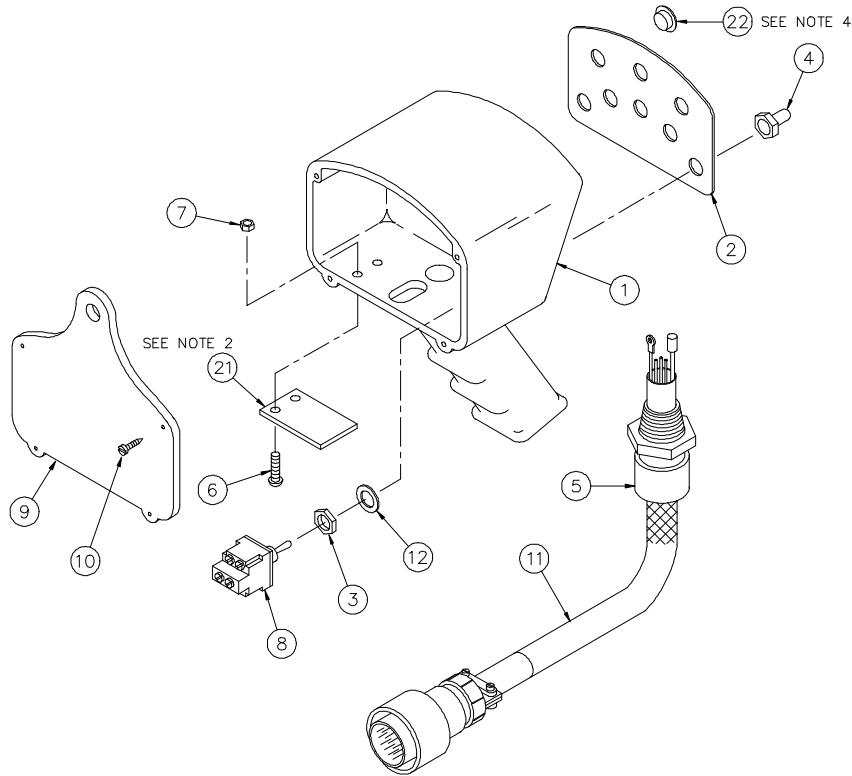

PENDANT

P/N 680021

<u>ITEM</u>	<u>QTY</u>	<u>P/N</u>	<u>DESCRIPTION</u>
1	1	-	PENDANT HOUSING
2	1	-	DECAL/COVER PLATE
3	6	-	NUT
4	6	-	TOGGLE BOOT
5	1	480567	HUBBELL CONNECTOR CORD GRIP
6	2	-	CAPSCREW #10-24 NC x 3/4
7	2	-	HEX LOCK NUT #10-24 NC
8	4	-	TOGGLE SWITCH DPDT
9	1	-	HOUSING BACK PLATE
10	4	-	SELF THREADING ROUND HEAD SCREW #6 x 3/4
11	1	680041	BAYONET CABLE ASSEMBLY
12	6	-	LOCK WASHER
13	3	660302	CONDUCTOR ASSEMBLY
14	4	636600	JUMPER
15	4	622346	CONDUCTOR ASSEMBLY
16	2	622347	CONDUCTOR ASSEMBLY
17	-	-	-
18	1	-	TOGGLE ON/OFF SWITCH
19	1	480526	CONDUCTOR ASSEMBLY
20	2	750737	CABLE TIE
21	1	-	TRIGGER OPENING COVER
22	3	-	PLASTIC 1/2" PLUG <i>(see note 4)</i>

NOTES:

1. Tie-off the following unused conductors with Item 20 inside of pendant:
Blue with Red T Orange with Red T Black with White T
2. Before installing Item 21 (Cover), add RTV Sealant between cover & Pendant Housing.
3. Securely wrap unused power connector terminals (Ref. Item #19) with electrical tape; terminals must be unwrapped when adding switches for options.
4. Item #22 (Plastic Plugs) are to be installed in any unused holes in Cover Plate Item #2.
5. Items 3, 4, 8, & 12 may be purchased as a **REPLACEMENT DPDT SWITCH KIT** using **P/N 380005**.
6. Items 3, 4, 12, & 18 may be purchased as a **REPLACEMENT ON/OFF SWITCH KIT** using **P/N 380001**.

PENDANT

P/N 680021

7. Items 1, 2, 6, 7, 9, 10, 21, & 22 may be purchased as a **REPLACEMENT HOUSING KIT** using **P/N 380002**.

PENDANT CABLE ASSEMBLY

P/N 680041

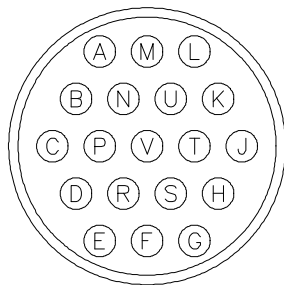
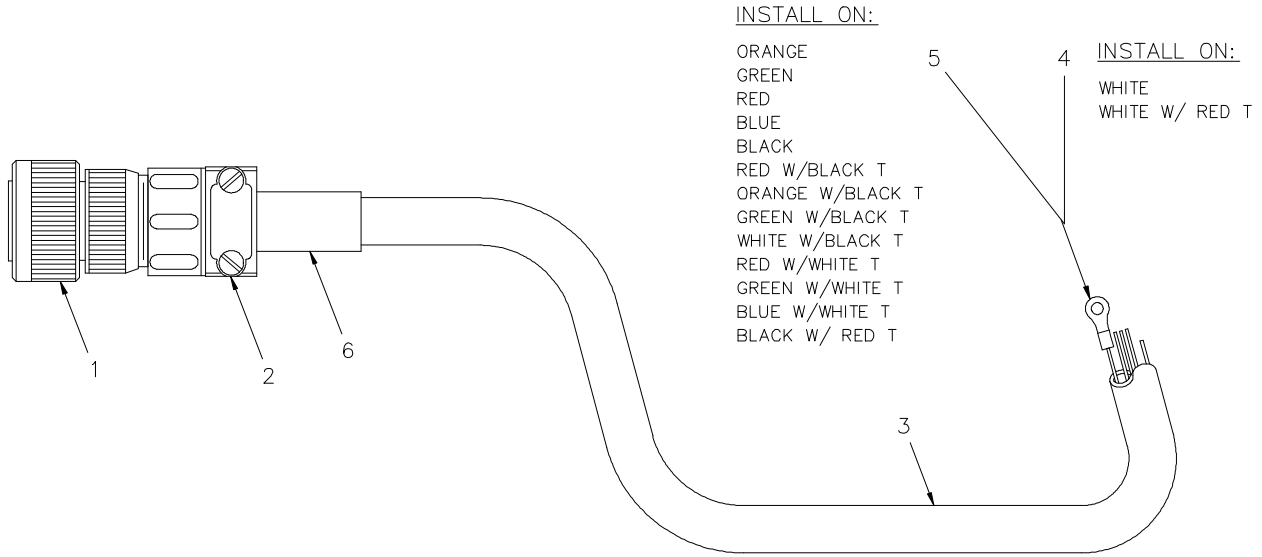

WIRING GUIDE

A-RED	L-WHITE
B-GREEN	M-BLUE W/BLACK T
C-ORANGE	N-BLACK W/WHITE T
D-RED W/WHITE T	P-GREEN W/WHITE T
E-BLACK	R-BLUE W/WHITE T
F-RED W/BLACK T	S-BLACK W/RED T
G-BLUE	T-WHITE W/RED T
H-ORANGE W/BLACK T	U-ORANGE W/RED T
J-GREEN W/BLACK T	V-BLUE W/RED T
K-WHITE W/BLACK T	

ITEM	QTY	P/N	DESCRIPTION
1	1	366098	19 PIN BAYONET PLUG
2	1	480515	CABLE CLAMP
3	30'	480594	19 PIN CONDUCTOR CABLE
4	2	000101	RING TERMINAL #6 / 14-16 GA
5	13	002012	RING TERMINAL #6 / 18-22 GA
6	6"	490243	HEAT SHRINK TUBING x 6"

TRAVELING BLOCK ASSEMBLY

P/N 360480

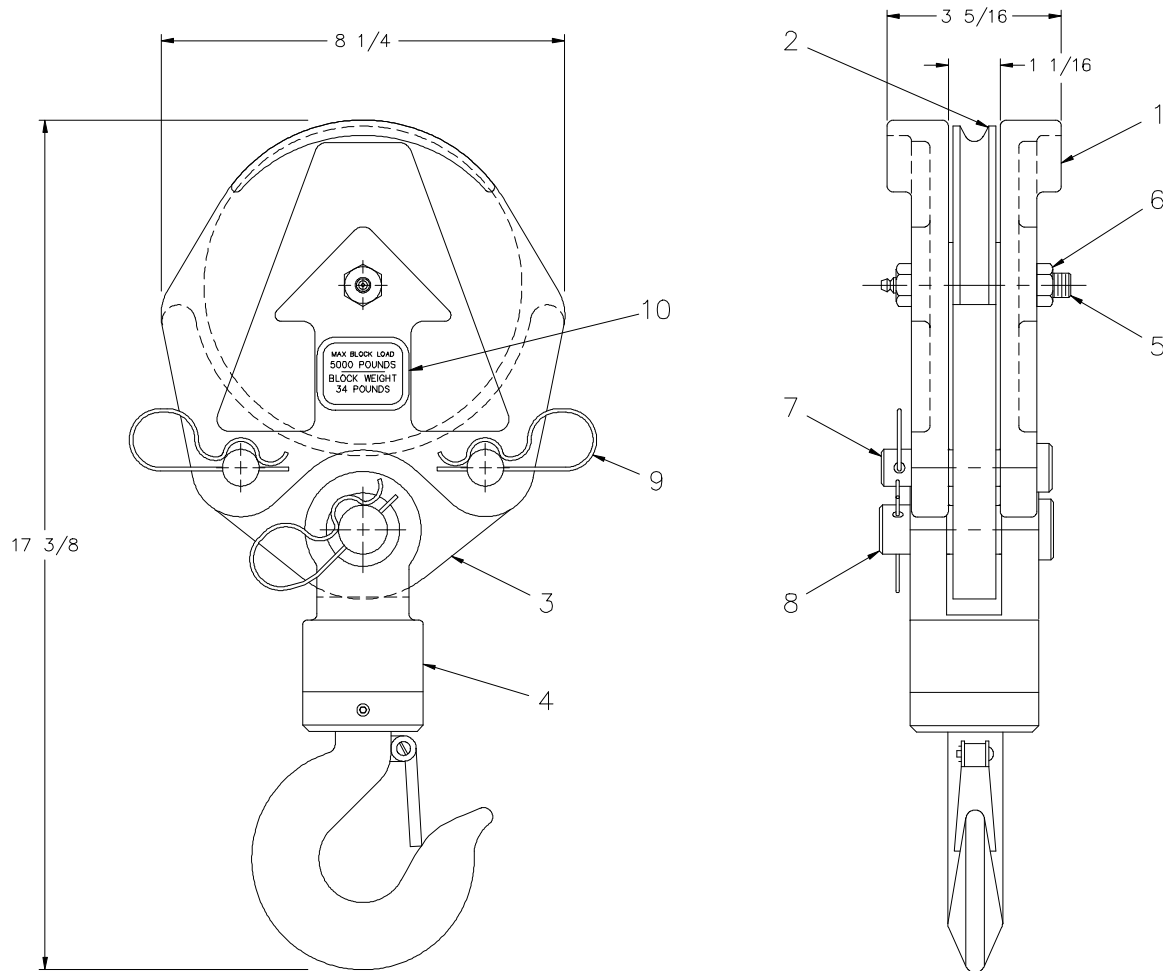

<u>ITEM</u>	<u>QTY</u>	<u>P/N</u>	<u>DESCRIPTION</u>
1	2	480362	SIDE PLATE
2	1	240236	SHEAVE ASSEMBLY
3	1	480364	LOWER TACKLE
4	1	480371	SWIVEL HOOK - 3 TON
5	1	480372	BOLT x 3 1/4 GR8 w/ GREASE ZERK
6	1	017800	LOCK NUT 1/2 NC
7	2	480367	BLOCK PIN
8	1	480368	SWIVEL HOOK PIN
9	3	360124	HITCH PIN
10	2	360480-100	MAXIMUM LOAD DECAL

LOAD CHART 10-16-20 BOOM

MODEL 5005EH

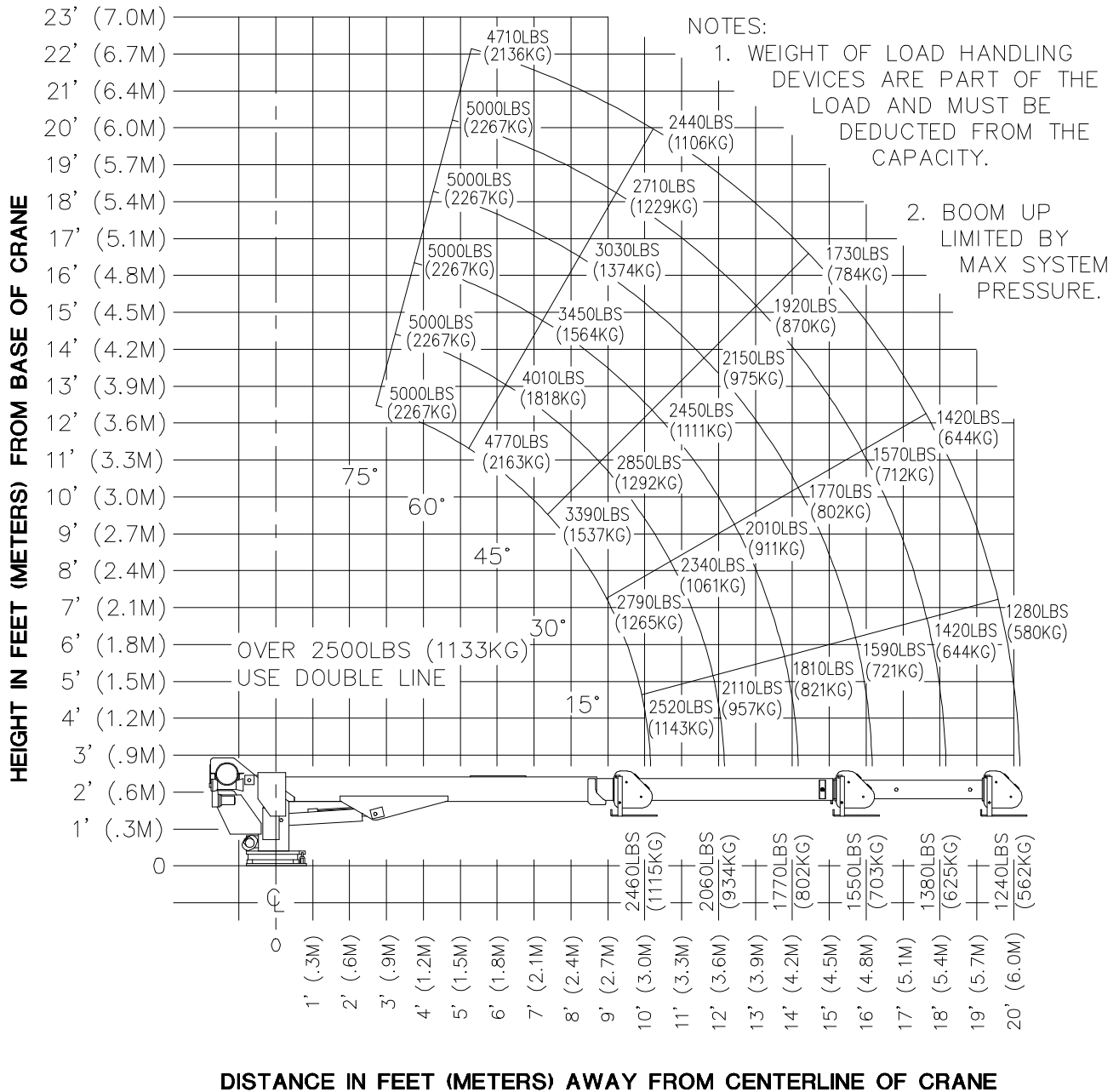

MODEL 5005EH 10-16 MAXIMUM LOAD CHART

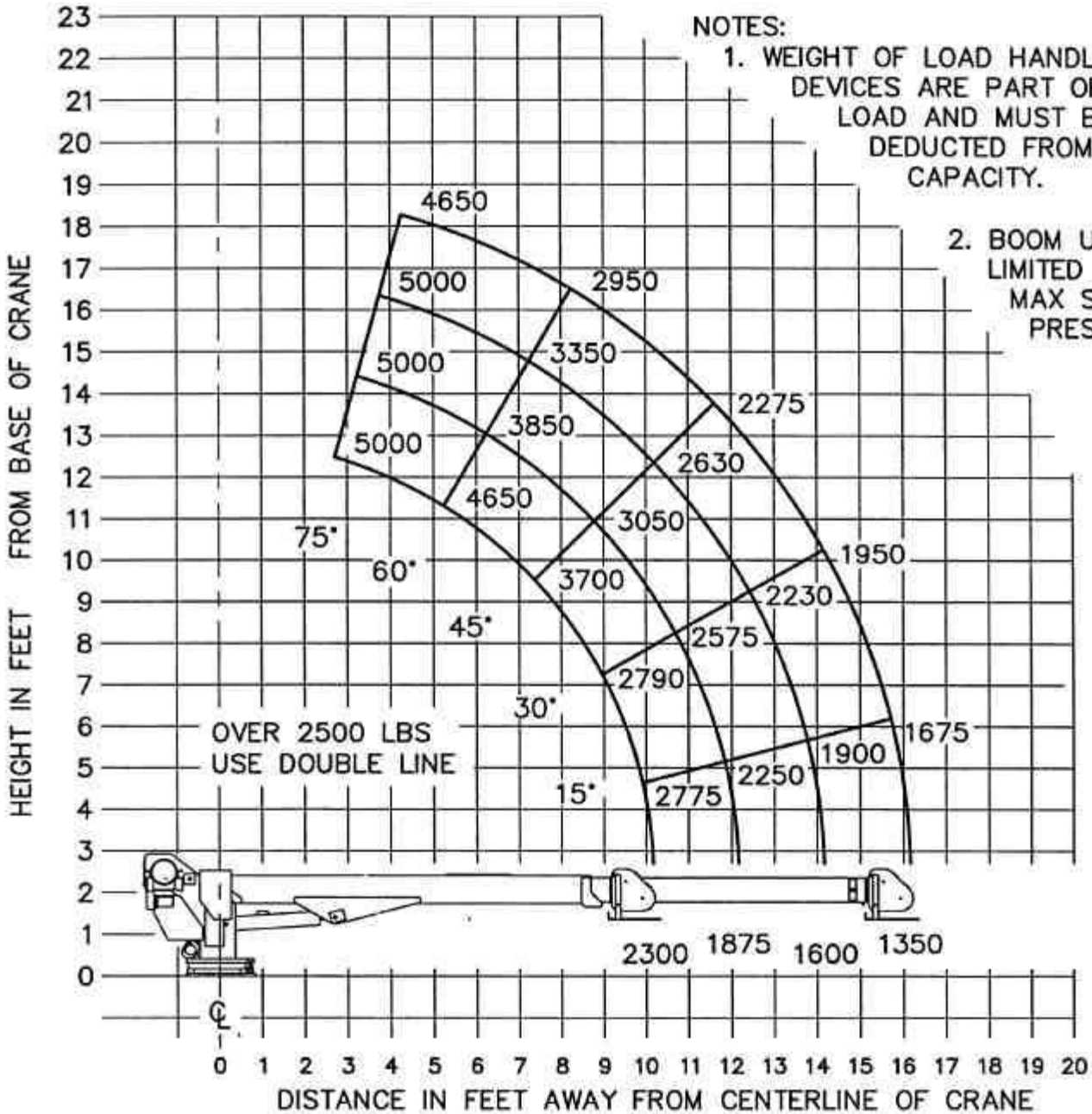

AW-349
5005EH LOAD CHART
10-16 BOOM



AUTO CRANE COMPANY

P. O. BOX 581510 • TULSA, OKLAHOMA 74158

Limited Warranty

Auto Crane will warranty to consumer for a period of twelve months from date of purchase that each new Auto Crane product it sells will be free under normal use and service, from defects in material and workmanship. Date of purchase will be honored as either date of purchase by distributor or his date of sale of the product as substantiated by Distributor Delivery Report.

Obligation of Auto Crane under this warranty is limited to replacement or repair of parts that appear to manufacturer after review and / or inspection to be defective. This warranty does not obligate Auto Crane to bear the cost of labor or transportation charges in connection with the replacement or repair of defective parts. Responsibility for customer's claims arising from misapplication, abuse, misuse or alteration of equipment or parts lies with the distributor or user and no warranty obligation is assumed in the circumstances by Auto Crane.

Auto Crane will in no event be liable for any consequential damages or contingent liabilities arising out of the failure of any Auto Crane product or parts to operate properly.

Auto Crane makes no warranty in respect to component accessories, same being subject to the warranties of their respective manufacturers.

If field service, at the request of buyer, is rendered and fault is found not to be with Auto Crane's product, the buyer shall pay the time and expense of the field representative. Claims for service labor or other expenses that have been incurred by the buyer without approval or authorization of Auto Crane will not be accepted.

AUTO CRANE COMPANY IS UNDER NO OBLIGATION TO EXTEND THIS WARRANTY TO ANY CUSTOMER FOR WHICH AN AUTO CRANE WARRANTY REGISTRATION CARD HAS NOT BEEN COMPLETED AND MAILED TO AUTO CRANE COMPANY WITHIN FIFTEEN (15) DAYS AFTER DATE OF PURCHASE.

AC-57

11/87