

D-series

ARTICULATED DUMP TRUCKS
Mk VII

B25D | B30D | B35D | B40D | B45D | B50D



Blu@dvantage™

BELL

Courtesy of Machine.Market

Get more from your truck

If you're looking to deliver more to your bottom line, choose Bell Articulated Dump Trucks.

These D-series ADTs handle heaped payloads with faster cycle times and best-in-class fuel efficiency - so you'll move more material at lower cost. They're highly reliable, too, with high-strength, welded-alloy steel chassis and components that are durable and optimised for no unnecessary weight. And with their oscillating frame joint, articulated steering, and high-floatation tyres, these hard working haulers won't let wet weather or steep grades dampen your plans.

- Extensive use of high-strength, lightweight materials gives these trucks the best payload-to-mass ratios and hauling efficiencies in each class.
- With their oscillating frame and high-floatation tyres, Bell trucks won't leave you stuck on muddy, rutted or hilly terrain.
- The redesigned sound-suppressed cab features fatigue beating controls, advanced diagnostic monitor and a sealed switch module for convenient, fingertip operation of numerous functions.
- Fuel-efficient Stage 3b emission certified engines deliver clean power without compromise in all conditions. Leading-edge emissions technology ensures rapid engine response and dependable cold-start performance.



Specifications	B25D	B30D	B35D	B40D	B45D	B50D
Gross power	210 kW 282 hp	240 kW 322 hp	295 kW 402 hp	335 kW 450 hp	375 kW 503 hp	375 kW 503 hp
Operating mass						
Empty	18 400 kg	18 690 kg	28 230 kg	29 850 kg	32 980 kg	34 520 kg
Loaded	41 600 kg	45 990 kg	60 730 kg	66 851 kg	73 980 kg	79 920 kg
2:1 heaped capacity	14 m ³	17 m ³	20.5 m ³	23 m ³	25.5 m ³	28 m ³
Rated payload	23 200 kg	27 300 kg	32 500 kg	37 000 kg	41 000 kg	45 400 kg



Add enhancements such as a Stage 3b emission-certified engine, solid state electrical system and spacious, redesigned cab with refined controls, and you have everything you need to maximise uptime and productivity.

- Limited-slip differentials (B25D to B30D), controlled traction differentials (B35D to B50D) and transfer case diff-lock provide a traction boost in poor underfoot conditions.
- The best-in-class payload-to-weight ratio means that more of your fuel cost is spent moving the material, not the machine - decreasing your cost per tonne.
- The fully automatic six-speed planetary transmission with torque converter lock up maximises fuel efficiency.
- Automatic retardation slows the truck when the operator backs off the accelerator pedal - for more confidence on steep grades and enhanced brake life.
- Electronic unit injection and common-rail fuel systems provide high injection pressures even at low engine speed for improved cold-starting ability, low-speed response, and reduced emissions.
- High-travel suspension keeps all tyres in constant ground contact for optimum traction.
- The short front end provides an industry-best approach angle that allows these ADTs to attack steep terrain.



1

1. Transfer case inter-axle differential delivers equal torque to each axle when traction is favourable. When conditions get ugly, engage the diff-lock on the go to deliver torque to the tyres that can best use it.



2

2. The central oscillation joint, high suspension travel on all axles, and balanced weight distribution provide the agility and ability to navigate hostile terrain.

3. Front-suspension damping helps minimize vibration, while the centre-mounted seat reduces the roll often experienced in off-road conditions - for comfortable productivity.



3



4

4. Available tailgate helps retain more material for bigger loads. It automatically opens as dump body is raised.



Haul of Fame



Bell ADTs give you the competitive edge. Boasting faster haul cycles and industry-leading fuel economy, they move material at the lowest cost per tonne of any comparable-size truck. Best in-class payload-to-mass ratio gives you more power and agility to carry the load, for maximum productivity and profitability. What really sets these apart from other material movers is their ability to thrive on rough terrain, steep grades and mud. Try one to appreciate the difference.

Bringing you tomorrow technology today



Bell Equipment has implemented an SCR system to meet stage 3b emissions standards. Called Bell Blu@dvantage™, it is an SCR package designed specially for the off-highway market.

With SCR technology customers are able to reduce harmful Nitrogen Oxides while being able to save on fuel. So Blu@dvantage™ is not just healthy for the environment; it's healthy for your wallet too.

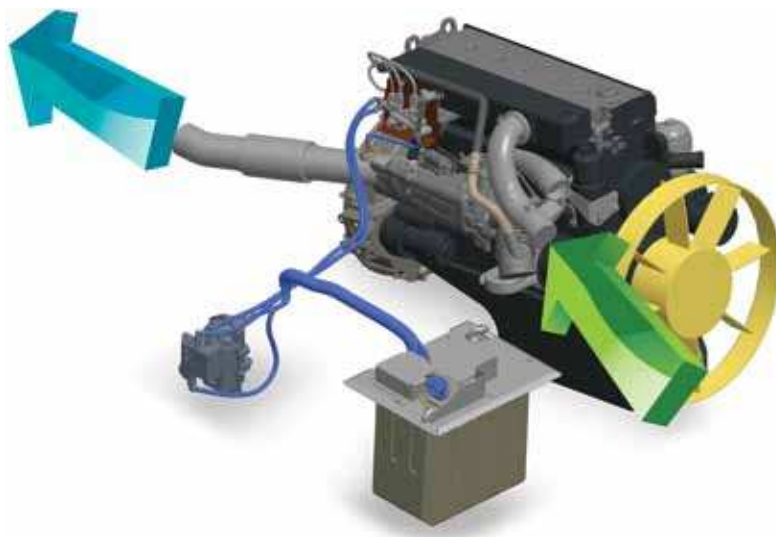

Blu@dvantage™

And with world leading benefits

- Reduced emissions
- Improved engine efficiency
- Lower fuel consumption
- Improved power on certain models
- Improved torque
- Improved engine response

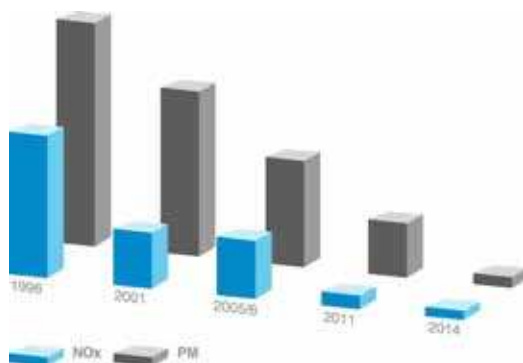

A combination of an optimally tuned engine and weight optimised complete machine package ensure that Bell ADT's have a minimal carbon footprint

AdBlue® is non-toxic, odourless and simple to refill

AdBlue® is injected into the flow of the exhaust gases and reacts with the NOx gases in the catalytic convertor to form harmless Nitrogen and water

Field tests on the new Blu@dvantage™ system show up to 15% saving in fuel over the previous Bell ADT's.

AdBlue® usage is approximately 3-5% of your fuel usage.

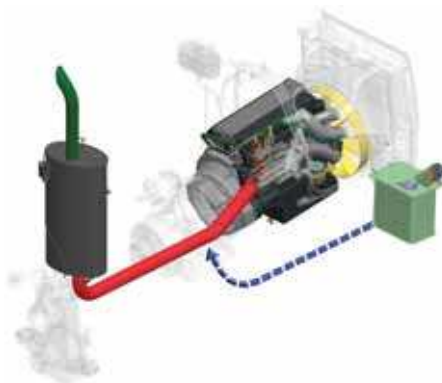

12 km/H	AdBlue Level 0% 100%	MENU
62 ←	Bintip Count 22.0	BACK
100.0 oDO	87.3 HRS	NEXT
		SELECT



Built for comfort

What operator wouldn't want to climb behind the wheel of a Bell ADT? It's spacious, quiet, climate-controlled cab is loaded with productivity-boosting comfort and convenience features that rival some SUVs.

From the state-of-the-art multifunction monitor and fully customisable controls to air-suspension seat, tilt/telescoping steering wheel and optional CD player with high-output speakers, the D-series provides everything your operators need to perform at their best. Unparalleled comfort.

Our innovative Comfort Ride system...

...is available as an option on the B35, B40, B45 and B50 trucks to even further enhance ride comfort by ensuring minimal whole body vibration exposure. Productivity increases, through increased cycle times, and reduced haul road maintenance are even further benefits of the simple, but extremely successful system. Long haul cycles with rough, hard roads will see maximum benefit, especially on the unladen run.



- Who says you can't take it with you? There's a place for a coffee cup, in-door storage for an insulated flask or other carry-ons, and even a hot/cold box for refreshments.



- An intuitive monitor reveals vital operating information, detailed diagnostic readings of most sensors and switches and dump body function settings.



- Convenient sealed switch pad provides fingertip control of numerous productivity enhancing functions including: **Dump body upper limit. Soft stop / hard stop selection, I-Tip and Speed Control.**



- The standard sound-suppression package significantly reduces noise levels and operator fatigue.
- The adaptive transmission control adjusts clutch engagement to ensure smooth, consistent shifts throughout the life of the truck.
- A fully adjustable air-suspension seat is optimally positioned behind the front axle to help smooth out the ride when the going gets rough.
- Easy-to-understand instruments and intuitive controls wrap around the operator so they're easier to view and operate.
- A heavy-duty bi-level climate-control system with automotive-style louvres keeps the glass clear and cab comfortable.
- The spacious centre-mount seat and a comprehensive mirror package provide exceptional all-around visibility.
- You won't find retarder pedals or levers in a Bell truck. Retarder aggressiveness is simply set on the switch pad. Everything else is automatic.

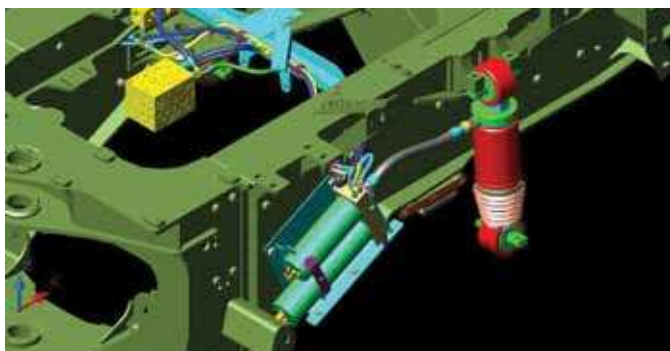

The front suspension consists of independent suspension cylinders that allow the oil flow and pressure to be constantly changed to minimise the effects of machine movement. Sensors in the frame continually measure and accommodate for bumps in the surface while lateral sensors also measure any roll and constantly adjust cylinders to accommodate for this.

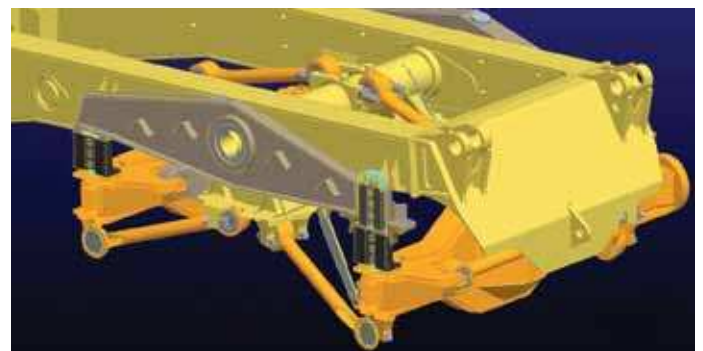

The incorporation of the dual stage sandwich block allows for differing suspension characteristics between laden and unladen runs. The simple mechanical solution has proved durable while being extremely effective in smoothing out the ride.

- Automatic transmission retardation provides superior braking power and reduces service brake wear.
- Hydraulically actuated dry-disc brakes deliver consistent “on-the-mark” braking, even in cold weather. Simplified design makes them easy to maintain.
- Oil-immersed wet-disc brakes on the B50D, B45D and B40D (optional on B35D and B30D) are virtually maintenance-free.
- B50D, B45D and B40D hydraulic, transmission, and transfer case oil coolers employ a hydraulically driven fan that runs only as needed, helping conserve power and fuel.
- Efficient viscous direct-drive fans in all Bell trucks provide engine and charge-air cooling.

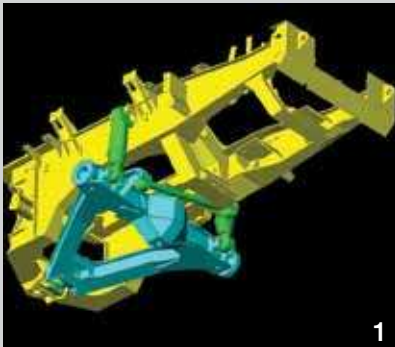

1



2



3

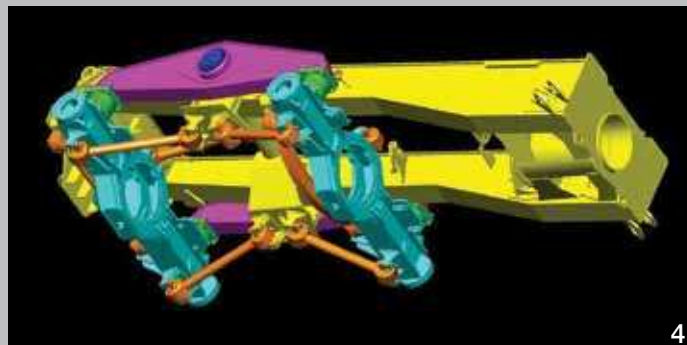

4

Nothing's built as strong as a Bell

Built smarter to work harder, these lean machines boast the material-moving muscle you need without the mass to feed.

Their lower mass reduces powertrain and structural stress. Other uptime-boosting features include enhanced diagnostics, solid-state sealed switches and re-inforced articulation joints to list but a few. When you know how they're built, you'll run a Bell.



1. The high-strength steel chassis delivers strength and rigidity without excess weight.
2. Planetary powershift transmission controls optimise shift points and protect the transmission from operator error and abuse. Thicker clutch plates, generous lubrication flow, and heavy-duty cooling ensure long life.
3. High-strength steel and widely spaced taper roller bearings in the articulation area enhance long-term durability.
4. Rough terrain demands tough suspensions such as the kind on a Bell ADT. Heavy-duty components absorb shocks and come back for more. You get best-in-class ground clearance, too.

Here's the lowdown daily operating cost

You won't have to dig deep to uncover the many ways we've simplified service and made the D-series less expensive to maintain. Easy-to-reach dipsticks, see-through reservoirs, sight gauges and grouped service points make quick work of the daily routine. High-hour oil and filter change intervals reduce costs and planned downtime. Quick-change filters and extended engine and hydraulic oil-service intervals reduce costs and provide more uptime. Plus, an advanced diagnostic monitor and diagnostic test ports help you troubleshoot problems and make informed maintenance decisions.

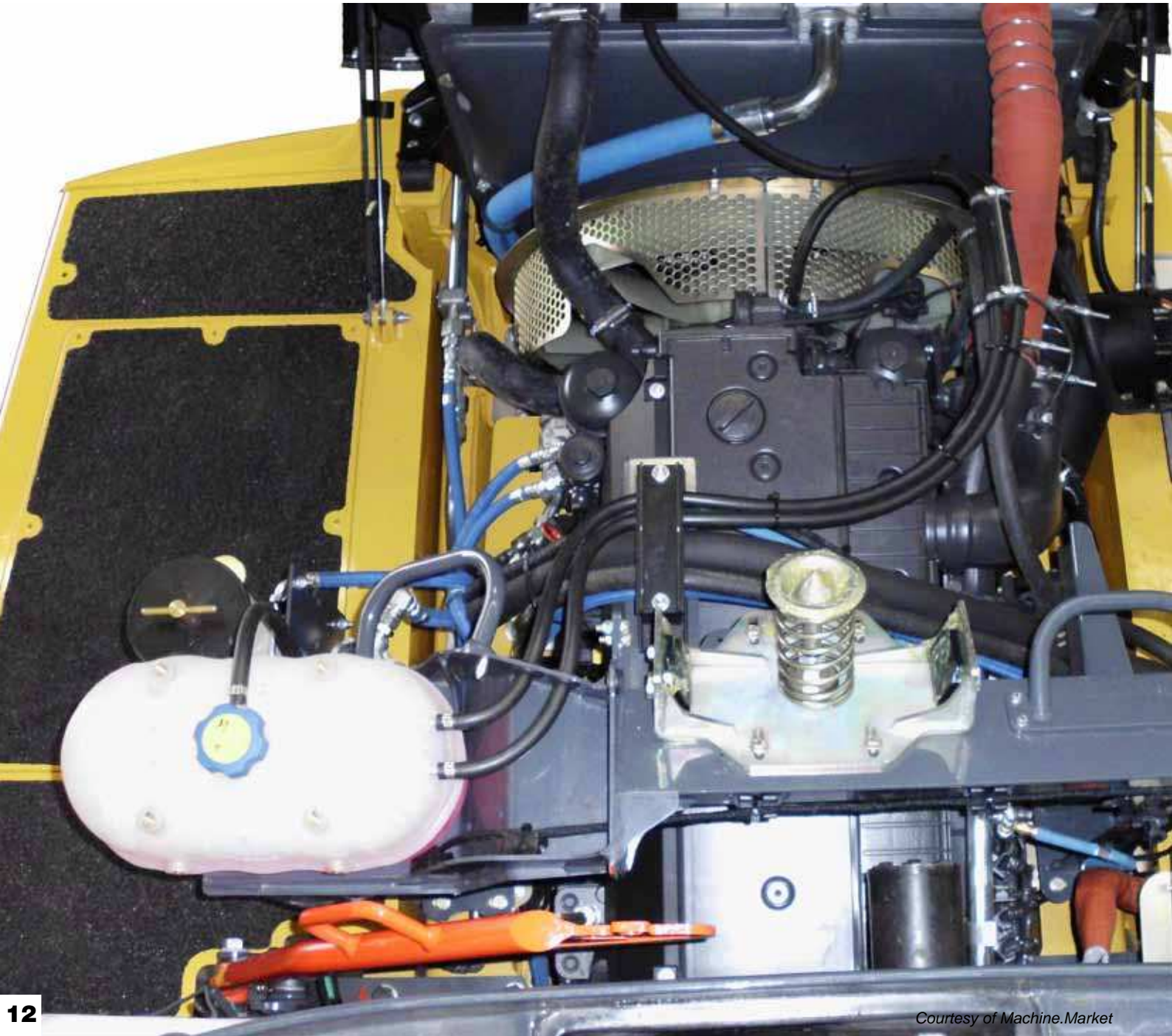

on ts

- The engine dipstick and oil fill, oil and fuel filters and coolant reservoir are readily accessible.
- Available environmental drains allow quick, no-spill changes.
- Engine, transmission and hydraulic oil-change intervals of 500 hrs and 2 000 hrs add up to more uptime and less expense.
- The load-sensing hydraulic system was designed with simplicity in mind. Fewer components result in greater reliability and service ease.
- Your Bell Service Centre has the parts and back-up you need to stay productive and offers a wide variety of preventative maintenance and support programmes to help you control costs.



1. The cab can be tilted without special tools in minutes, for convenient service access to drivetrain components.



2. If something goes wrong, the diagnostic monitor provides service codes and supporting info to help you quickly pinpoint the problem.

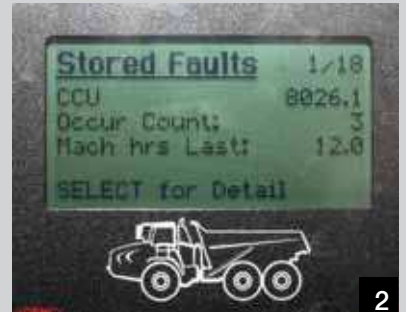

3. Easily accessible test ports allow technicians to troubleshoot problems more quickly.



4. An in-cab load centre simplifies fuse replacement. Fewer relays, connectors and harnesses mean higher reliability.



5. See-through fluid reservoirs (B25D and B30D) and sight gauges let you check fluid levels at a glance.



6. The centralised lube bank places difficult-to-reach nipples within reach. The convenient lube chart helps ensure that nothing gets overlooked.



Safety is our Business

By listening to our customers and reacting quicker to a changing workplace we provide a vehicle that exceeds application safety standards.



- The exclusive on-board weighing option presents the operator with real time information on the payload while the machine is being loaded. A 'limp home' mode can also be activated if the machine is significantly over-loaded.



- The park brake automatically applies when neutral is selected and it is not possible to engage neutral at speed. Torque dependent park brake release (hill assist) ensures no roll back on slopes.



ess too



- The incorporation of a Pitch and Roll sensor in the vehicle allows the bin to not be operated if the truck is in an unsafe position.



- Keyless start, driver identity, and access codes ensures no unauthorized operation of your equipment.



- Our quiet operator cabins are ROPS/FOPS certified with air suspension operator seat. Both operator and trainer seat have retractable lap belts with automatically locking retractors.



- Reverse cameras are available for factory or on site fitment ensuring full view when reversing.



- Full hand-rails (to ISO 2876) can be installed to provide even more safety when performing engine checks.



- Both operator or site selectable maximum speed control allows the vehicle to automatically decelerate and apply the retarder to prevent onsite speeding.



- Optional Tyre pressure - monitoring System ensures that the operator has real time information on all tyres pressure and temperature conditions.



- The best in class retarder and engine braking automatically applies when the operator lifts his foot off the accelerator. Retarder aggressiveness can be simply adjusted on the sealed switch module ensuring maximum descent control for all conditions.

- All trucks can be set up to automatically sound the horn when starting or switching between forward and reverse.

Where ever you are...

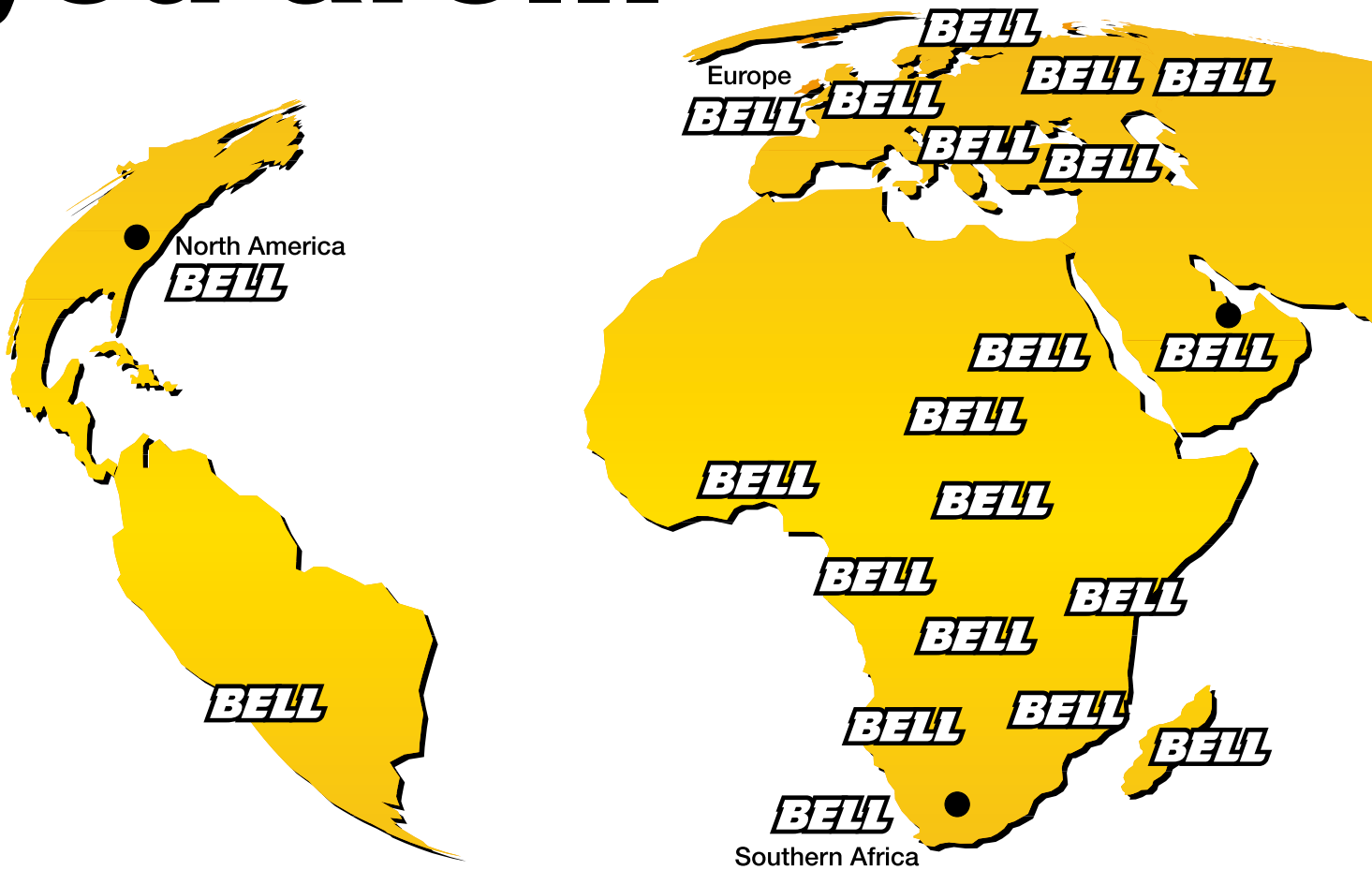

...we got you covered

Through our own Network as well as approved dealers and strategic alliances we can supply and support to the Global market. Develop a lasting and meaningful partnership with Bell Equipment through Bell Assure, your tailor made support structure furnished with all the after-sales tools you need to give you best value, peace of mind and a unique aftersales experience.

South African Manufacturing Facility



Global Logistics Center



BELL

ASSURE



red

German Manufacturing Facility



Used - Through the Bell Equipment used network, global opportunities can be explored to ensure best residual value when upgrading your trucks. Used units include full condition assessments guaranteeing peace of mind as well as different options to meet your criteria and budget.



Finance - Finance options can be tailored to your business needs through strong partnerships in all regions. Professional interaction and industry know how ensures fast and easy access to packages that meet your business profile - helping you win.



Parts - We believe there is more to Bell Equipment Company than simply our machines. We have an international network of dealers and subsidiaries stocking genuine Bell Parts you would expect available immediately. We pride ourselves that all care is taken to ensure the quality of replacement Bell Parts we stock meets the same stringent quality requirements as the parts we use in building our machines.



Technical Support - Bell Customer Support centres are located in key positions throughout all territories in which we operate to ensure that Bell Equipment is able to effectively support its products worldwide through parts availability and technical backup. As the worlds one stop shop, Bell Equipment also provides factory direct support for a full line of solid equipment 24 hours a day 365 days a year through Bell Technical Support. Such support includes Factory Technical Analysts, International Product Support, Training and complete literature.

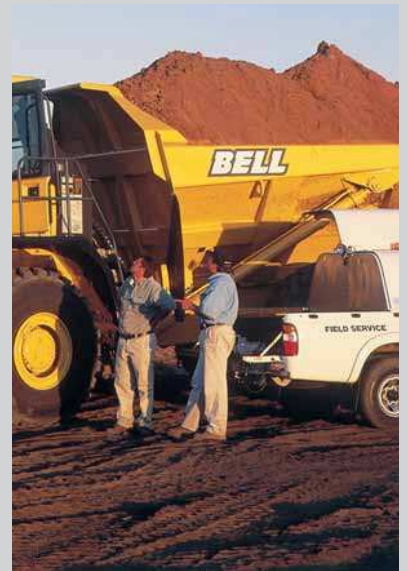

Fleetm@tic - Fleet management just got smarter. In its quest to provide lowest cost per tonne solutions to its customers and push the boundaries of earthmoving technology, Bell Equipment has developed Fleetm@tic, its own remote satellite fleet management tool.



Fleet management got smarter



global positioning satellite

Bell Fleetm@tic is an essential tool in running your business whether used for optimising your production, controlling your fleet or detecting any losses. The cutting edge Fleetm@tic technology keeps Bell owners in touch with their equipment all the time. It provides accurate up-to-date operational data, production data, fault data as well as machine location and movements, in a cost effective and effortless manner.

Packages:

Fleetm@tic Lite

gives a daily report. This data includes fuel burn, location and machine hours; in effect, information from the previous day. Reports are available in a downloadable daily, weekly and monthly format. All Mk VI ADT's are equipped with our LITE Package at no extra cost.



Fleetm@tic Std

has all the features of Lite, and in addition packaged production data is sent every shift. Reports can be split by up to three different shifts. Ten event messages per day are also included in the reports. Events can also be set up for immediate reporting via a predetermined cell phone number.



Fleetm@tic Max

has all the features of Lite and Std, but offers virtually real-time monitoring. Packaged data is sent at ignition on and off, and at loading and tipping. Individual load cycle reports are also available. For instance it is possible to see the machine's location within the last several minutes, or fuel consumption and tonnage for the last haul cycle for virtual real-time control.



t just



Easily Locate and track your machine on an interactive web based map, which allows you to zoom into your worksite to within several meters. Cutting edge Iridium technology ensures global coverage and unsurpassed reliability. Geofence boundaries can easily be set up with notification to both operator and owner when these boundaries have been crossed.

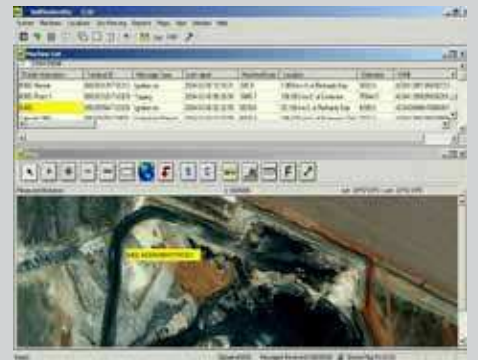

Receive on-line or email reports that cover each machine in your fleet. Reports cover everything you need to manage your site effectively. A Spreadsheet format can also be simply downloaded which will allow you to manipulate the data to meet your current reporting structure.



Historic playback allows you to check on which stockpiles are being worked on to ensure optimal efficiency. Data can be used to reconstruct events, giving you all the information to take any corrective action. Time bar reporting is also beneficial to those machines out on rent.

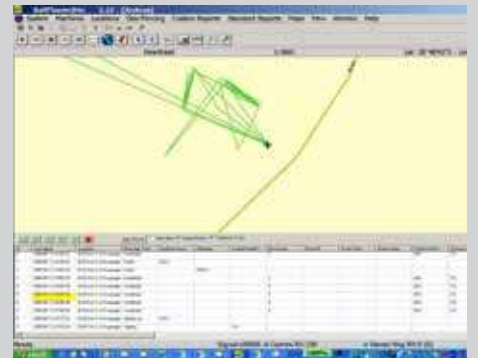

Solid state, sealed componentry ensures maximum reliability in even the harshest environments.



Fleetsm@tic Max Plus has all the features of Lite, Std and Max, and in addition has individualised tipping reports with coordinates for each loading and tipping.



Information below is included in the basic data download.

- Date
- Odometer (km)
- Hours
- Tonnes moved
- Loads
- Distance
- Fuel level (litres)
- Fault codes
- Fuel burn (l/hr)
- Idle time laden (%)
- Idle time un-laden (%)
- Overload (%)
- Speed (km/h)
- Over rev count
- Brake usage (%)
- Events
- Cycle Times



Specifications

	B25D	B30D
ENGINE Gross power Net Power Torque Displacement Fuel tank capacity Auxilliary Brake AdBlue Tank Capacity Certification	Mercedes Benz inline 6 cylinder, turbocharged, intercooled, low emission diesel engine 210 kW (282 hp) @ 2,200 rpm 203 kW (272 hp) @ 2,200 rpm 1,120 Nm (826 lbft) @ 1,200 -1,600 rpm 7.2 litres (439 cu.in) 310 l (85 US gal) Exhaust brake Engine Valve Brake (EVB) 31 l (8.2 US gal) OM 926 LA meets Europe (EU) stage 3b emissions regulations	Mercedes Benz inline 6 cylinder, turbocharged, intercooled, low emission diesel engine 240 kW (322 hp) @ 2,200 -1,600 rpm 232 kW (311 hp) @ 2,200 -1,600 rpm 1,250 Nm (922 lbft) @ 1,200 - 1,600 rpm 7,2 litres (439 cu.in) 310 l (85 US gal) Exhaust brake Engine Valve Brake (EVB) 31 l (8.2 US gal) OM 926 LA meets Europe (EU) stage 3b emissions regulations
TRANSMISSION Layout Gear Layout Gears Clutch type Control type Torque Converter	Fully automatic ZF planetary transmission Engine mounted Constant meshing planetary gears, clutch operated 6 Forward, 1 Reverse Hydraulically operated multi-disc Electronic Hydrodynamic with lock-up in all gears	Fully automatic ZF planetary transmission Engine mounted Constant meshing planetary gears, clutch operated 6 Forward, 1 Reverse Hydraulically operated multi-disc Electronic Hydrodynamic with lock-up in all gears
TRANSFER BOX Manufacturer Model Layout Output Differential	Remote mounted Bell 13100 Three in-line helical gears. 67/33 torque proportioning, Pneumatically lockable on the move.	Remote mounted Bell 13100 Three in-line helical gears. 67/33 torque proportioning, Pneumatically lockable on the move.
AXLES Model	High strength steel fabricated with spiral bevel type gears on the limited slip locking differential and heavy duty outboard planetary gears. Bell 15T	High strength steel fabricated with spiral bevel type gears on the limited slip locking differential and heavy duty outboard planetary gears. Bell 18T
BRAKING SYSTEM SERVICE BRAKE Maximum brake force PARK & EMERGENCY Maximum brake force AUXILIARY BRAKE Maximum retardation	Dual circuit, full hydraulic actuation caliper brakes on all wheels 164 kN (36,900 lbf) Spring applied, air released driveline mounted disc. 396 kN (89,000 lbf) Automatic exhaust brake and Engine Valve Brake (EVB) Variable Adjustable Hydraulic retarder in transmission 442 kW (593 hp)	Dual circuit, full hydraulic actuation caliper brakes on all wheels or wet disc brakes option 164 kN (36,900 lbf) Spring applied, air released driveline mounted disc. 396 kN (89,000 lbf) Automatic exhaust brake and Engine Valve Brake (EVB) Variable Adjustable Hydraulic retarder in transmission 442 kW (593 hp)
WHEELS Tyre	Earthmover 23.5R25	Earthmover 23.5R25 or 750/65R25
FRONT SUSPENSION	Semi-independent, quad rubber mounted leading arm linkages supported by nitrogen and oil filled struts.	Semi-independent, quad rubber mounted leading arm linkages supported by nitrogen and oil filled struts.
REAR SUSPENSION	Pivoting walking beams, distributing equal load through laminated rubber suspension blocks. Each axle is coupled to the chassis by four rubber-bushed links for ideal vertical movement.	Pivoting walking beams, distributing equal load through laminated rubber suspension blocks. Each axle is coupled to the chassis by four rubber-bushed links for ideal vertical movement.
HYDRAULIC SYSTEM Flow Pressure Filter	Variable displacement with load sensing system incorporating a ground driven emergency steering pump. 184 l/min (48.6 gal/min) 25 Mpa (3,915 psi) 5 microns	Variable displacement with load sensing system incorporating a ground driven emergency steering pump. 184 l/min (48.6 gal/min) 25 Mpa (3,915 psi) 5 microns

B25D

B30D

	B25D	B30D
STEERING SYSTEM Lock to lock turns Steering Angle	Hydrostatically actuated, low effort, fast acting. Two double-acting steering cylinders 4.1 45°	Hydrostatically actuated, low effort, fast acting. Two double-acting steering cylinders 4.1 45°
DUMPING SYSTEM Raise Time Lowering Time Tipping Angle	Two double-acting, single stage, dump cylinders 12 s 6 s 70°	Two double-acting, single stage, dump cylinders 12 s 6 s 70°
PNEUMATIC SYSTEM System Pressure	Air drier with heater and integral unloader valve, serving park brake and auxiliary functions 810 kPa (117 psi)	Air drier with heater and integral unloader valve, serving park brake and auxiliary functions 810 kPa (123 psi)
ELECTRICAL SYSTEM Voltage Battery Type Battery Capacity Alternator Rating	24 V Two maintenance free permanently sealed 2 X 105 Ah 28 V 80 A	24 V Two maintenance free permanently sealed 2 X 105 Ah 28 V 80 A
VEHICLE SPEEDS	1st 2nd 3rd 4th 5th 6th R 8 13 22 31 44 53 8 km/h 5 8 14 19 28 33 5 mph	1st 2nd 3rd 4th 5th 6th R 8 13 22 31 44 53 8 km/h 5 8 14 19 28 33 5 mph
OPERATING MASSES Front Middle Rear Total	UNLADEN LADEN 9,620 kg 12,860 kg 4,420 kg 14,400 kg 4,360 kg 14,340 kg 18,400 kg 41,600 kg	UNLADEN LADEN 9,710 kg 13,350 kg 4,490 kg 16,320 kg 4,490 kg 16,320 kg 18,690 kg 45,990 kg
GROUND PRESSURE 23.5R25 Front Middle Rear	LADEN (No sinkage) LADEN (With sinkage) 246 kPa 133 kPa 287 kPa 146 kPa 287 kPa 146 kPa	LADEN (No sinkage) LADEN (With sinkage) 265 kPa 138 kPa 330 kPa 165 kPa 330 kPa 165 kPa
750/65 Front Middle Rear	LADEN (No sinkage) 234 kPa 277 kPa 277 kPa	LADEN (With sinkage) 115 kPa 137 kPa 137 kPa
LOAD CAPACITY Struck Capacity SAE 2:1 Capacity SAE 1:1 Capacity SAE 2:1 Capacity with Autogate Rated Payload	11 m ³ (14,4 cu.yd) 14 m ³ (18,3 cu.yd) 18 m ³ (23,5 cu.yd) 14,5 m ³ (19 cu.yd) 23 200 kg (51,147 lbs)	13 m ³ (17 cu.yd) 17 m ³ (22,2 cu.yd) 20,5 m ³ (26,8 cu.yd) 17,5 m ³ (22,9 cu.yd) 27 300 kg (60,186 lbs)
CAB	ROPS/FOPS certified 71 dBA internal sound level measured according to ISO 6396	ROPS/FOPS certified 71 dBA internal sound level measured according to ISO 6396
OPTION WEIGHTS Bin liner Tailgate Extra wheelset	1,053 kg 651 kg 536 kg	1,192 kg 708 kg 536 kg

B25D

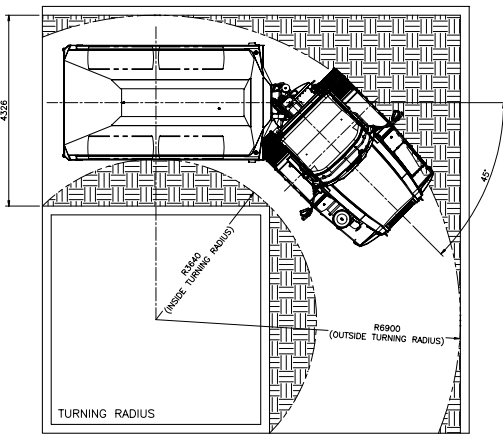
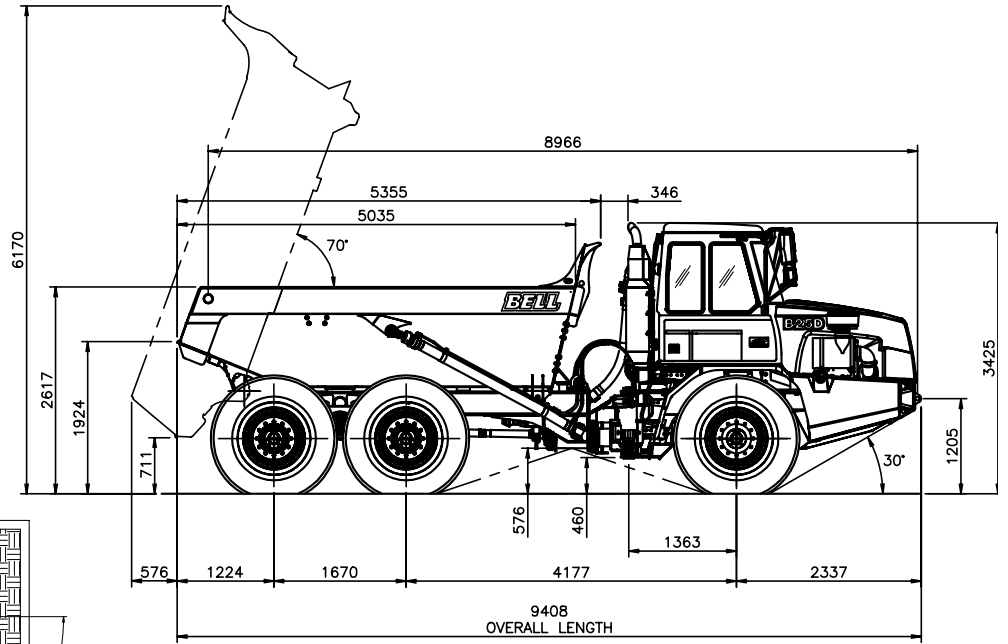
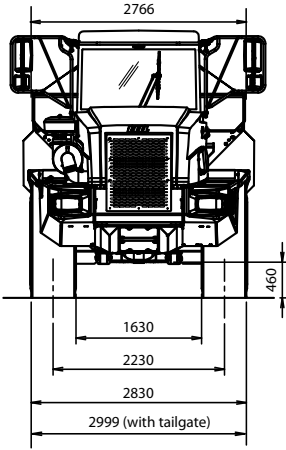

GRADEABILITY

1. Determine tractive resistance by finding intersection of vehicle mass line and grade line. NOTE: 2% typical rolling resistance is already assumed in chart and grade line.
2. From this intersection, move straight left across charts until line intersects rimpull curve.
3. Read down from this point to determine maximum speed attained at that tractive resistance.

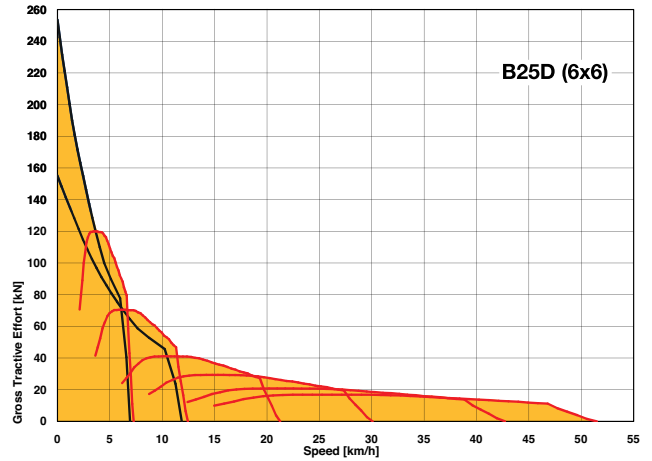
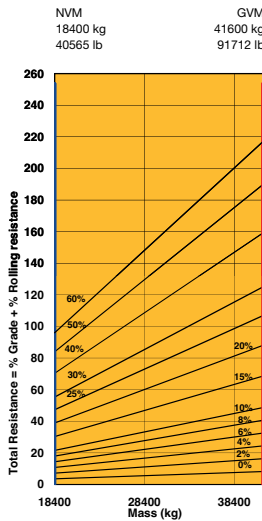

RETARDATION

1. Determine retardation force required by finding intersection of vehicle mass line.
2. From this intersection, move straight left across charts until line intersects the curve. NOTE: 2% typical rolling resistance is already assumed in chart.
3. Read down from this point to determine maximum speed.

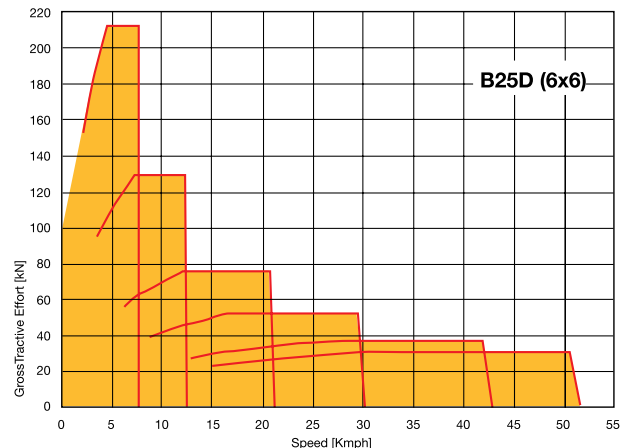
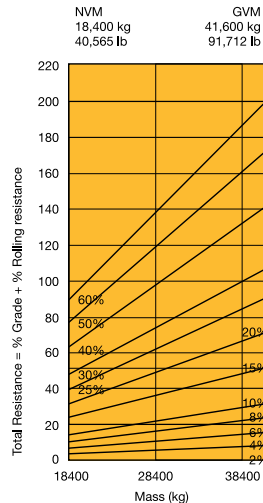

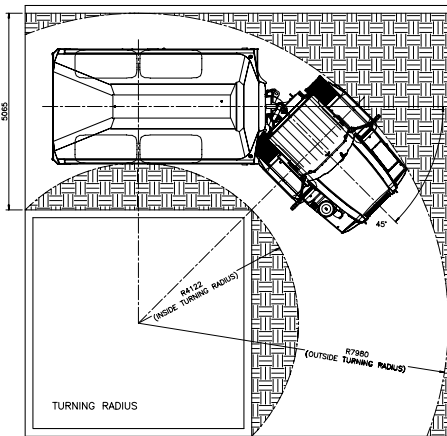
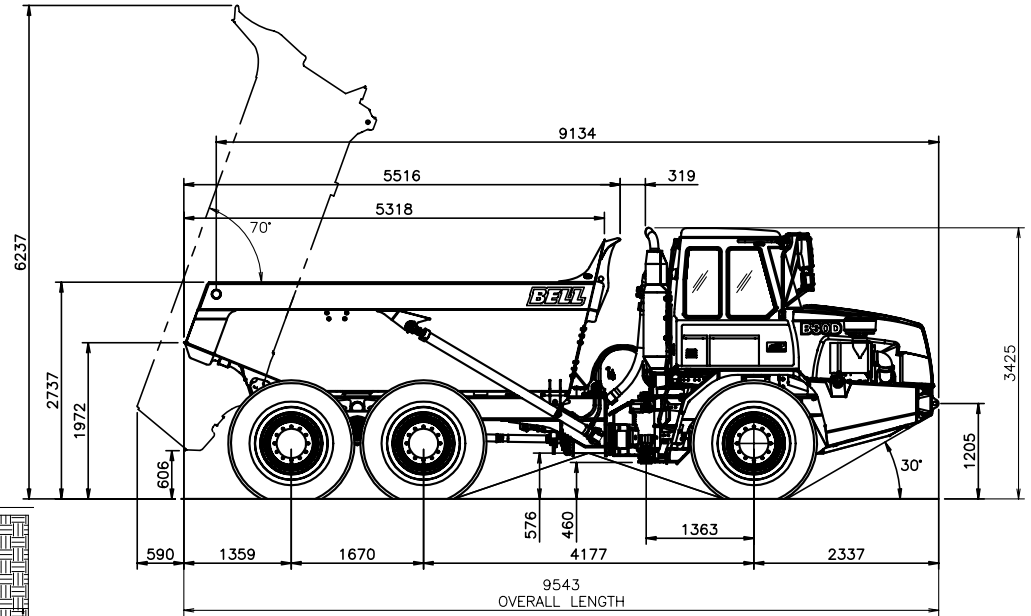
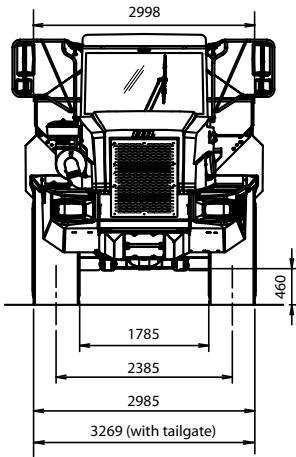

GRADEABILITY

1. Determine tractive resistance by finding intersection of vehicle mass line and grade line. NOTE: 2% typical rolling resistance is already assumed in chart and grade line.
2. From this intersection, move straight left across charts until line intersects rimpull curve.
3. Read down from this point to determine maximum speed attained at that tractive resistance.

NVM	GVM
18,690 kg	45,990 kg
41,204 lb	101,391 lb

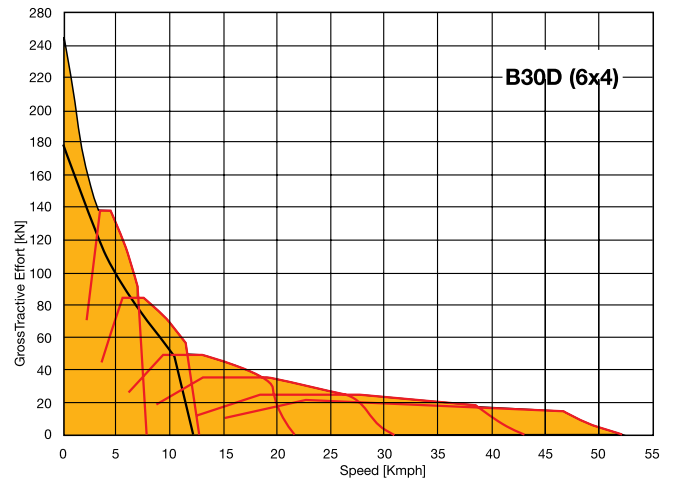
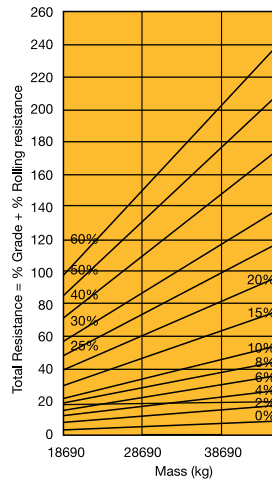

RETARDATION

1. Determine retardation force required by finding intersection of vehicle mass line.
2. From this intersection, move straight left across charts until line intersects the curve. NOTE: 2% typical rolling resistance is already assumed in chart.
3. Read down from this point to determine maximum speed.

NVM	GVM
18,690 kg	45,990 kg
41,204 lb	101,391 lb

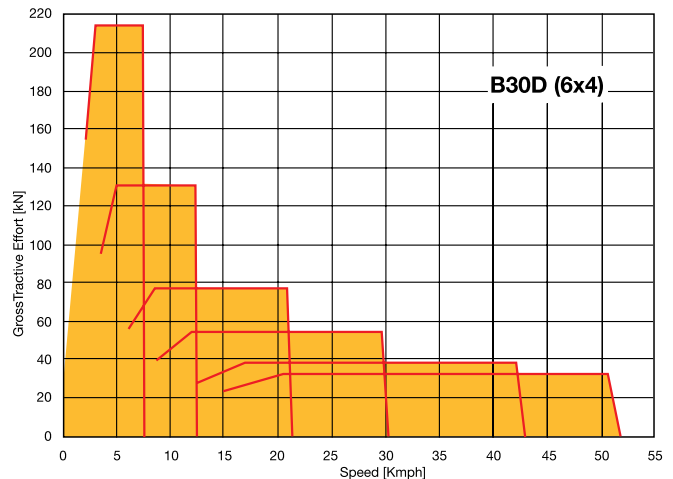
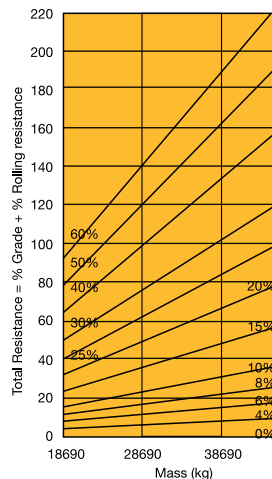

Specifications

	B35D	B40D
ENGINE Gross power Net Power Torque Displacement Fuel tank capacity Auxilliary Brake AdBlue Tank Capacity Certification	Mercedes Benz V6, turbocharged, intercooled, low emission diesel engine 295 kW (402 hp) @ 1,800 rpm 288 kW (390 hp) @ 1,800 rpm 2,000 Nm (1,475 lbft) @ 1,300 rpm 11,95 litres (730 cu.in) 445 litres (118 US gal) Automatic exhaust brake Engine Valve Brake (EVB) 40 l (11 US gal) OM 501 LA meets Europe (EU) stage 3b emissions regulations	Mercedes Benz V6, turbocharged, intercooled, low emission diesel engine 335 kW (429 hp) @ 1,800 rpm 325 kW (416 hp) @ 1,800 rpm 2,100 Nm (1,549 lbft) @ 2,200 rpm 11,95 litres (730 cu.in) 445 litres (118 US gal) Automatic exhaust brake Engine Valve Brake (EVB) 40 l (11 US gal) OM 501 LA meets Europe (EU) stage 3b emissions regulations
TRANSMISSION Layout Gear Layout Gears Clutch type Control type Torque Converter	Fully automatic Allison planetary transmission Engine mounted Constant meshing planetary gears, clutch operated 6 Forward, 1 Reverse Hydraulically operated multi-disc Electronic Hydrodynamic with lock-up in all gears	Fully automatic Allison planetary transmission Engine mounted Constant meshing planetary gears, clutch operated 6 Forward, 1 Reverse Hydraulically operated multi-disc Electronic Hydrodynamic with lock-up in all gears
TRANSFER BOX Manufacturer Model Layout Output Differential	Remote mounted Bell 17100 Three in-line helical gears. Interaxle 33/67 proportional differential, Pneumatically lockable on the move.	Remote mounted Bell 17100 Three in-line helical gears. Interaxle 33/67 proportional differential, Pneumatically lockable on the move.
AXLES Model	High strength steel fabricated with spiral bevel type gears on the Controlled Traction differential and heavy duty outboard planetary gears. Bell 25T	High strength steel fabricated with spiral bevel type gears on the Controlled Traction differential and heavy duty outboard planetary gears. Bell 25T
BRAKING SYSTEM SERVICE BRAKE Maximum brake force PARK & EMERGENCY Maximum brake force AUXILIARY BRAKE Maximum Retardation	Dual circuit, full hydraulic actuation wet disc brakes on front and middle axles. 193 kN (43,388 lbf) Spring applied, air released driveline mounted disc. 440 kN (98,920 lbf) Automatic exhaust brake Engine Valve Brake (EVB) Variable Adjustable Hydraulic retarder 575 kW (771 hp)	Dual circuit, full hydraulic actuation wet disc brakes on front and middle axles. 218 kN (49,010 lbf) Spring applied, air released driveline mounted disc. 440 kN (98,920 lbf) Automatic exhaust brake Engine Valve Brake (EVB) Variable Adjustable Hydraulic retarder 575 kW (771hp)
WHEELS Tyre	Earthmover 26.5R25	Earthmover 29.5R25
FRONT SUSPENSION	Semi-independent, leading A-frame supported by nitrogen/oil struts.	Semi-independent, leading A-frame supported by nitrogen/oil struts.
REAR SUSPENSION	Pivoting walking beams equalise the load on each axle with laminated suspension blocks. Each axle is coupled to the chassis by a Tri-Link system of four rubber-bushed links for ideal vertical movement and a transverse link for lateral restraint.	Pivoting walking beams equalise the load on each axle with laminated suspension blocks. Each axle is coupled to the chassis by a Tri-Link system of four rubber-bushed links for ideal vertical movement and a transverse link for lateral restraint.
HYDRAULIC SYSTEM Flow Pressure Filter	Variable displacement with load sensing system incorporating a ground driven emergency steering pump. 300 l/min (79,26 gal/min) 25 Mpa (3,626 psi) 5 microns	Variable displacement with load sensing system incorporating a ground driven emergency steering pump. 300 l/min (79,26 gal/min) 25 Mpa (3,626 psi) 5 microns

B35D B40D

	B35D	B40D
STEERING SYSTEM Lock to lock turns Steering Angle	Hydrostatically actuated by two double acting cylinders, with ground-driven emergency steering pump. 4.7 42°	Hydrostatically actuated by two double acting cylinders, with ground-driven emergency steering pump. 4.7 42°
DUMPING SYSTEM Raise Time Lowering Time Tipping Angle	Two double-acting, single stage, dump cylinders 13 s 7,6 s 70°	Two double-acting, single stage, dump cylinders 13 s 7,6 s 70°
PNEUMATIC SYSTEM System Pressure	Air drier with heater and integral unloader valve, serving park brake and auxilliary functions 810 kPa (117 psi)	Air drier with heater and integral unloader valve, serving park brake and auxilliary functions 810 kPa (117 psi)
ELECTRICAL SYSTEM Voltage Battery Type Battery Capacity Alternator Rating	24 V Two maintenance free permanently sealed 2 X 105 Ah 28 V 80 A	24 V Two maintenance free permanently sealed 2 X 105 Ah 28 V 80 A
VEHICLE SPEEDS	1st 2nd 3rd 4th 5th 6th R 8 17 24 37 48 54 6,3 km/h 5 10.6 15 23 30 33.8 3.9 mph	1st 2nd 3rd 4th 5th 6th R 8 17 24 37 48 54 6,3 km/h 5 10.6 15 23 30 33.8 3.9 mph
OPERATING MASSES Front Middle Rear Total	UNLADEN LADEN 14,120 kg (31,129 lbs) 18,350 kg (40,455 lbs) 7,060 kg (15,565 lbs) 21,195 kg (46,727 lbs) 7,050 kg (15,543 lbs) 21,185 kg (46,705 lbs) 28,230 kg (62,236 lbs) 60,730 kg (133,887 lbs)	UNLADEN LADEN 14,650 kg (32,298 lbs) 19,587 kg (43,182 lbs) 7,810 kg (17,218 lbs) 23,842 kg (52,563 lbs) 7,390 kg (16,292 lbs) 23,422 kg (51,637 lbs) 29,850 kg (65,808 lbs) 66,851 kg (147,381 lbs)
GROUND PRESSURE Front Middle Rear	LADEN (No sinkage) LADEN (With sinkage) 303 kPa 159 kPa 338 kPa 177 kPa 338 kPa 177 kPa	LADEN (No sinkage) LADEN (With sinkage) 254 kPa 144 kPa 316 kPa 168 kPa 314 kPa 168 kPa
LOAD CAPACITY Struck Capacity SAE 2:1 Capacity SAE 1:1 Capacity SAE 2:1 Capacity with Autogate Rated Payload	16 m ³ (20.9 cu.yd) 20,5 m ³ (26.8 cu.yd) 24,5 m ³ (32 cu.yd) 21 m ³ (27.4 cu.yd) 32 500 kg (71.650 lbs)	18,5 m ³ (24.2 cu.yd) 23 m ³ (30 cu.yd) 27,5 m ³ (36 cu.yd) 24 m ³ (31.4 cu.yd) 37 000 kg (81.571 lbs)
CAB	ROPS/FOPS certified 75 dBA internal sound level measured according to ISO 6396	ROPS/FOPS certified 75 dBA internal sound level measured according to ISO 6396
OPTION WEIGHTS Bin liner Tailgate Extra wheelset	1,360 kg 804 kg 714 kg	1,473 kg 858 kg 937 kg

B35D

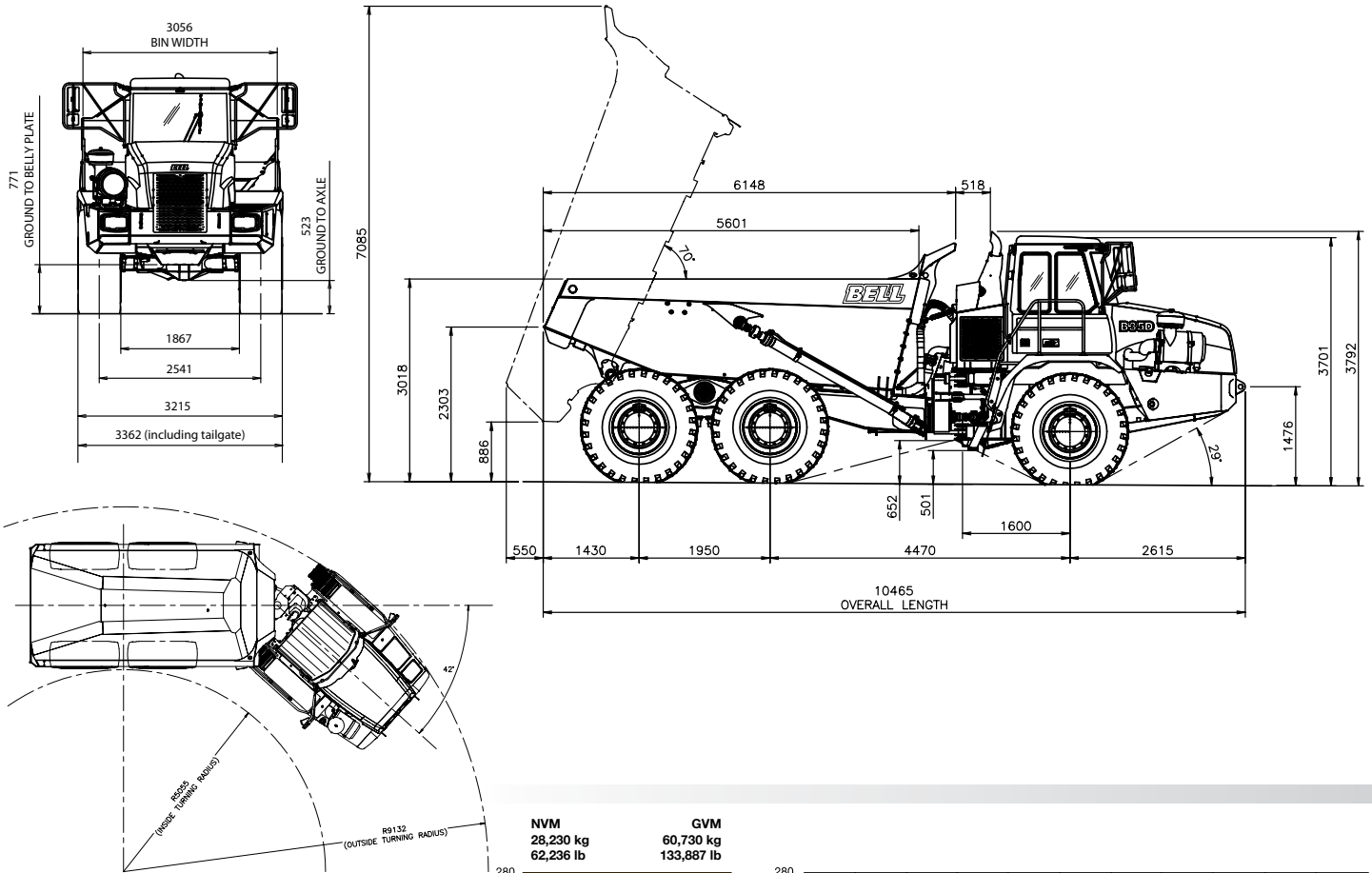

GRADEABILITY

1. Determine tractive resistance by finding intersection of vehicle mass line and grade line. NOTE: 2% typical rolling resistance is already assumed in chart and grade line.
2. From this intersection, move straight left across charts until line intersects rimpull curve.
3. Read down from this point to determine maximum speed attained at that tractive resistance.

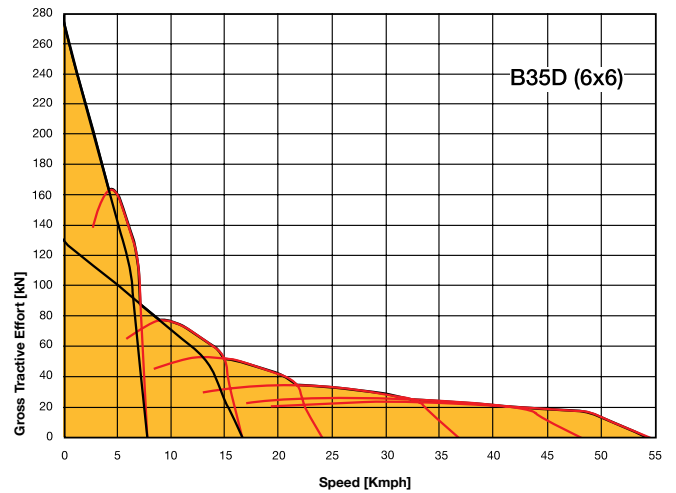
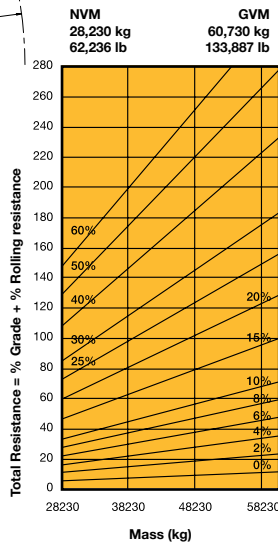

RETARDATION

1. Determine retardation force required by finding intersection of vehicle mass line.
2. From this intersection, move straight left across charts until line intersects the curve. NOTE: 2% typical rolling resistance is already assumed in chart.
3. Read down from this point to determine maximum speed.

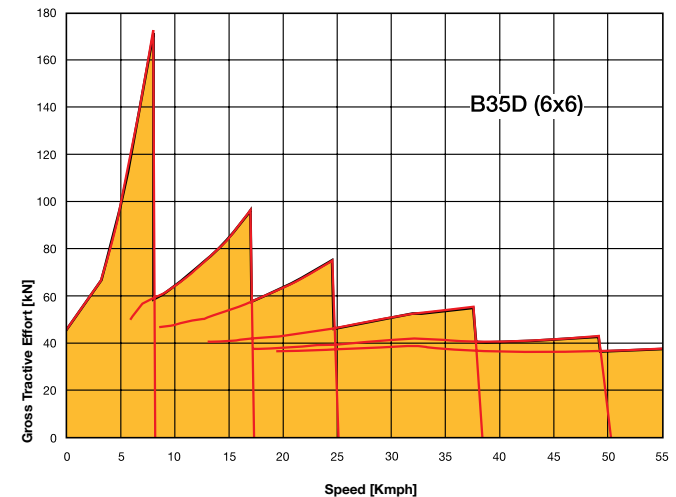
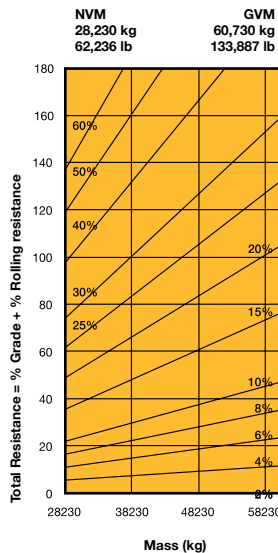

B40D

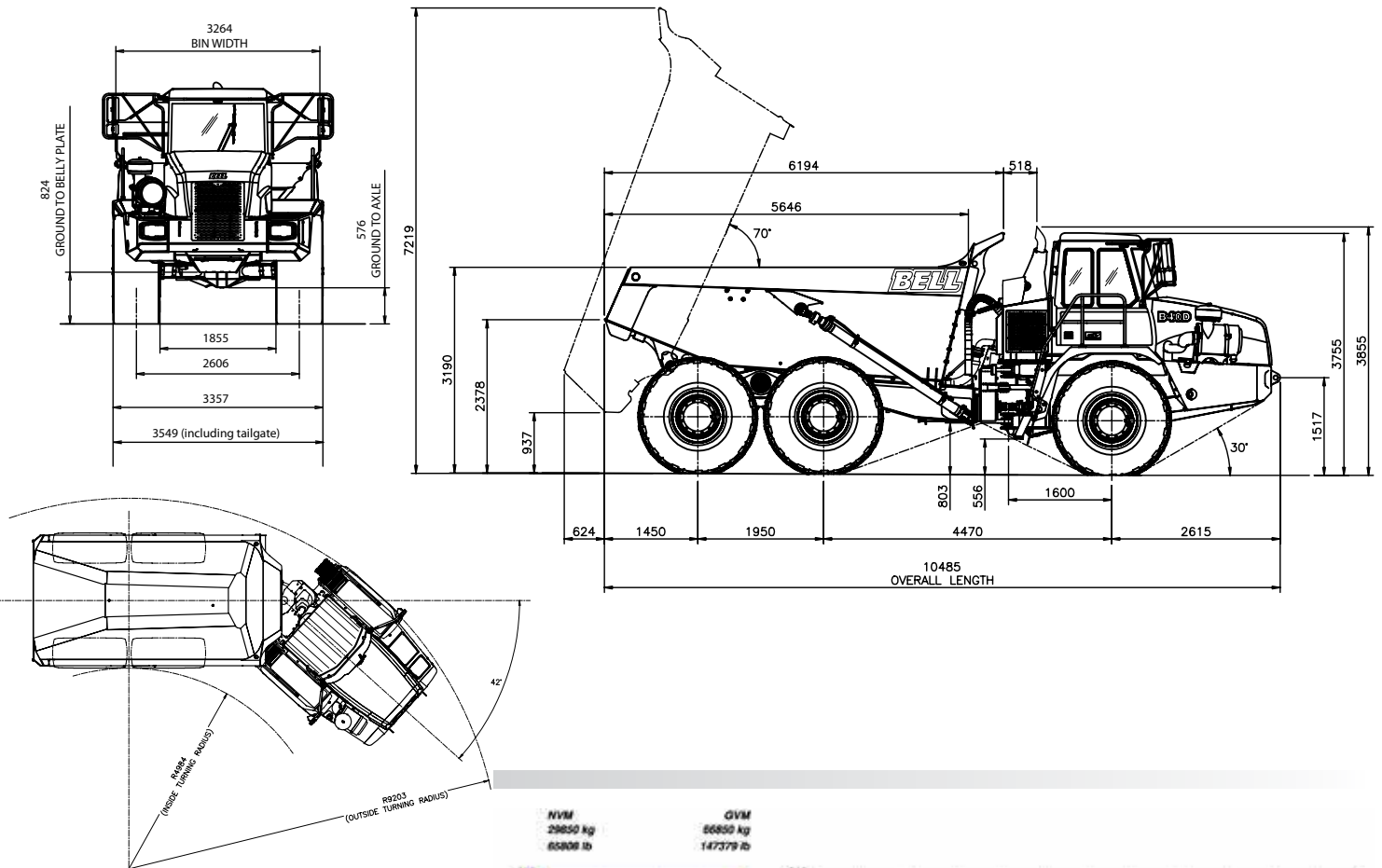

GRADEABILITY

1. Determine tractive resistance by finding intersection of vehicle mass line and grade line. NOTE: 2% typical rolling resistance is already assumed in chart and grade line.
2. From this intersection, move straight left across charts until line intersects rimpull curve.
3. Read down from this point to determine maximum speed attained at that tractive resistance.

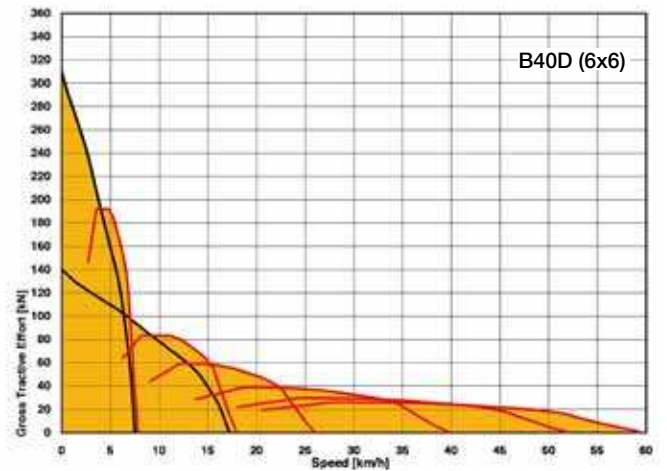
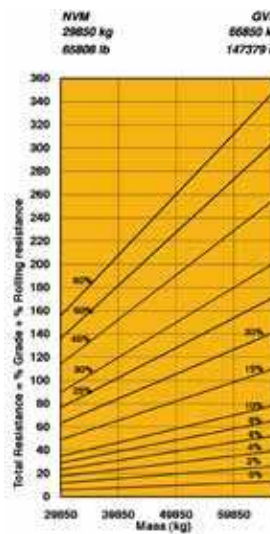

RETARDATION

1. Determine retardation force required by finding intersection of vehicle mass line.
2. From this intersection, move straight left across charts until line intersects the curve. NOTE: 2% typical rolling resistance is already assumed in chart.
3. Read down from this point to determine maximum speed.

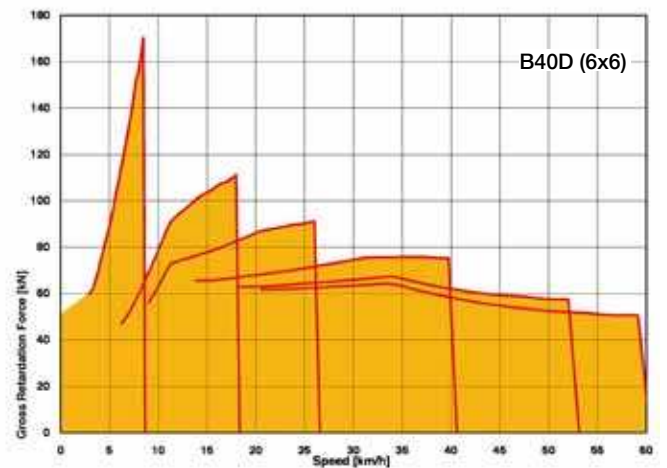
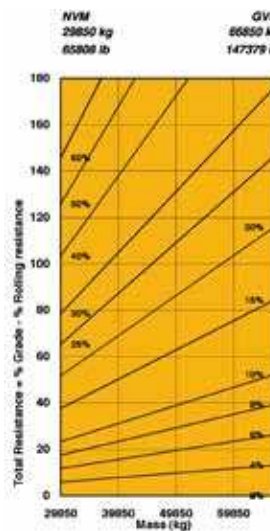

Specifications

	B45D	B50D
ENGINE Gross power Net power Torque Displacement AdBlue Tank Capacity Fuel tank capacity Certification	Mercedes Benz OM502LA, V-8 ,Turbocharged and intercooled 375 kW (503 hp) @ 1,800 rpm SAE J1349 364 kW (488 hp) @ 1,800 rpm 2,400 Nm (1,770 lbf) @ 1,200 rpm 15,93 litres (730 cu.in) 66 l (17.4 US gal) 575 litres (152 US gal) OM 502 LA meets Europe (EU) stage 3b emissions regulations	Mercedes Benz OM502LA, V-8 ,Turbocharged and intercooled 375 kW (503 hp) @ 1,800 rpm SAE J1349 364 kW (488 hp) @ 1,800 rpm 2,400 Nm (1,770 lbf) @ 1,200 rpm 15,93 litres (730 cu.in) 66 l (17.4 US gal) 575 litres (152 US gal) OM 502 LA meets Europe (EU) stage 3b emissions regulations
TRANSMISSION Layout Gear layout Gears Clutch type Control type Torque converter layout	Full automatic planetary transmission with integral retarder Engine mounted Constant meshing planetary gears, clutch operated 6 Forward, 1 Reverse Hydraulically operated multi-disc Electronic Hydrodynamic, with lockup in all gears	Full automatic planetary transmission with integral retarder Engine mounted with rear output Constant meshing planetary gears, clutch operated 6 Forward, 1 Reverse Hydraulically operated multi-disc Electronic Hydrodynamic, with lockup in all gears
TRANSFER BOX Manufacturer Model Layout Output differential	Bell 17100 Three in-line helical gears Interaxle 33/67 proportional differential, pneumatically/ spring lockable whilst stationary or on the move	Bell 17100 Three in-line helical gears Interaxle 33/67 proportional differential, pneumatically/ spring lockable whilst stationary or on the move
AXLES Final drive type Housing type	High strength steel fabricated with spiral bevel type gears on the Controlled Traction differential and heavy duty outboard planetary gears Outboard heavy duty planetary on all axles Steel fabricated	High strength steel fabricated with spiral bevel type gears on the Controlled Traction differential and heavy duty outboard planetary gears Outboard heavy duty planetary on all axles Steel fabricated
BRAKING SYSTEM SERVICE BRAKE Maximum brake force PARK & EMERGENCY Maximum brake force Maximum brake force AUXILIARY BRAKE	Dual circuit, full hydraulic oil immersed wet multidisc brakes on all three axles 399 kN (89,699 lbf) Spring applied, air released driveline mounted disc 440 kN (98,920 lbf)-Static 105 kN (23,605 lbf)-Dynamic Automatic exhaust brake Engine Valve Brake (EVB)	Dual circuit, full hydraulic oil immersed wet multidisc brakes on all three axles 399 kN (89,699 lbf) Spring applied, air released driveline mounted disc 440 kN (98,920 lbf)-Static 105 kN (23,605 lbf)-Dynamic Automatic exhaust brake Engine Valve Brake (EVB)
RETARDATION SYSTEM ENGINE BRAKE Maximum retardation power TRANSMISSION RETARDER Total retardation power (excl. service brakes)	Automatic exhaust brake and Engine Valve Brake (EVB) 340 kW (456 hp) Integral hydrodynamic, output speed dependant, six selectable levels of retardation 550 kW (737 hp)	Automatic exhaust brake and Engine Valve Brake (EVB) 340 kW (456 hp) Integral hydrodynamic, output speed dependant, six selectable levels of retardation 550 kW (737 hp)
WHEELS Tyre size Type	29.5R25 Radial Earthmover	875/65R29 Radial Earthmover
FRONT SUSPENSION	Semi-independent leading A-frame supported by nitrogen/oil struts	Semi-independent leading A-frame supported by nitrogen/oil struts
REAR SUSPENSION	Pivoting walking beams equalize the load on each axle with laminated suspension blocks. Each axle is coupled to the chassis by a Tri-Link system of three rubber-bushed links for ideal vertical movement and a transverse link for lateral restraint	Pivoting walking beams equalize the load on each axle with laminated suspension blocks. Each axle is coupled to the chassis by a Tri-Link system of three rubber-bushed links for ideal vertical movement and a transverse link for lateral restraint

B45D

B50D

	B45D	B50D																																																
HYDRAULIC SYSTEM	Variable displacement with load sensing system serving the prioritized steering, body tipping, suspension and brake functions. A ground-driven, load sensing emergency steering pump is integrated into the main system	Full load sensing system serving the prioritized steering, body tipping, suspension and brake functions. A ground-driven, load sensing emergency steering pump is integrated into the main system																																																
Pump Type	Variable displacement, loadsensing piston	Variable displacement, loadsensing piston																																																
Application	Steering, tipping, hydraulic brake charging, suspension and cooling fan drive	Steering, tipping, hydraulic brake charging, suspension and cooling fan drive																																																
Flow	350 l/min (92.5 US gal/min)	350 l/min (92.5 US gal/min)																																																
Pressure	25 MPa (3,626 psi)	25 MPa (3,626 psi)																																																
Filter	5 microns	5 microns																																																
STEERING SYSTEM	Hydrostatically actuated by two double acting cylinders, with ground-driven emergency steering pump.	Hydrostatically actuated by two double acting cylinders, with ground-driven emergency steering pump.																																																
Angle	42°	42°																																																
Lock to lock turns	4,2	4,2																																																
DUMPING SYSTEM	Two double-acting, single stage, dump cylinders	Two double-acting, single stage, dump cylinders																																																
Raise time	11.2 s (60° tip angle)	11.2 s (60° tip angle)																																																
Power down time	9.9 s (60° tip angle)	9.9 s (60° tip angle)																																																
Tipping angle	70° standard, or any lower angle programmable	70° standard, or any lower angle programmable																																																
PNEUMATIC SYSTEM	Air drier with heater and integral unloader valve, serving park brake and auxiliary functions	Air drier with heater and integral unloader valve, serving park brake and auxiliary functions																																																
System pressure	810 kPa (117 psi)	810 kPa (117 psi)																																																
ELECTRICAL SYSTEM																																																		
Voltage	24 V	24 V																																																
Battery type	Two maintenance free permanently sealed	Two maintenance free permanently sealed																																																
Battery capacity	2 x 105 Ah (optional 2 extra batteries)	2 x 105 Ah (optional 2 extra batteries)																																																
Alternator rating	28 V 80 A	28 V 80 A																																																
VEHICLE SPEEDS	<table border="1"> <tr> <td>1st</td><td>2nd</td><td>3rd</td><td>4th</td><td>5th</td><td>6th</td><td>R</td><td></td> </tr> <tr> <td>7</td><td>14</td><td>21</td><td>31</td><td>41</td><td>47</td><td>7</td><td>km/h</td> </tr> <tr> <td>4</td><td>9</td><td>13</td><td>19</td><td>25</td><td>29</td><td>4</td><td>mph</td> </tr> </table>	1st	2nd	3rd	4th	5th	6th	R		7	14	21	31	41	47	7	km/h	4	9	13	19	25	29	4	mph	<table border="1"> <tr> <td>1st</td><td>2nd</td><td>3rd</td><td>4th</td><td>5th</td><td>6th</td><td>R</td><td></td> </tr> <tr> <td>7</td><td>14</td><td>21</td><td>31</td><td>41</td><td>47</td><td>7</td><td>km/h</td> </tr> <tr> <td>4</td><td>9</td><td>13</td><td>19</td><td>25</td><td>29</td><td>4</td><td>mph</td> </tr> </table>	1st	2nd	3rd	4th	5th	6th	R		7	14	21	31	41	47	7	km/h	4	9	13	19	25	29	4	mph
1st	2nd	3rd	4th	5th	6th	R																																												
7	14	21	31	41	47	7	km/h																																											
4	9	13	19	25	29	4	mph																																											
1st	2nd	3rd	4th	5th	6th	R																																												
7	14	21	31	41	47	7	km/h																																											
4	9	13	19	25	29	4	mph																																											
OPERATING MASSES	UNLADEN	LADEN	UNLADEN	LADEN																																														
Front	17,230 kg (37,985 lbs)	21,190 kg (46,715 lbs)	17,550 kg (38,691 lbs)	23,440 kg (51,676 lbs)																																														
Middle	7,890 kg (17,394 lbs)	26,410 kg (58,223 lbs)	8,500 kg (18,739 lbs)	28,225 kg (62,292 lbs)																																														
Rear	7,860 kg (17,328 lbs)	26,380 kg (58,157 lbs)	8,470 kg (18,673 lbs)	28,255 kg (62,225 lbs)																																														
Total	32,980 kg (72,707 lbs)	73,980 kg (163,096 lbs)	34,520 kg (76,104 lbs)	79,920 kg (176,193 lbs)																																														
GROUND PRESSURE	LADEN	LADEN	LADEN	LADEN																																														
	(No sinkage)	(With sinkage)	(No sinkage)	(With sinkage)																																														
Front	277 kPa	151 kPa	274 kPa	145 kPa																																														
Middle	335 kPa	208 kPa	335 kPa	178 kPa																																														
Rear	333 kPa	208 kPa	335 kPa	178 kPa																																														
LOAD CAPACITY																																																		
Struck Capacity	20 m ³ (26.16 cu.yd)		22 m ³ (28.8 cu.yd)																																															
SAE 2:1 Capacity	25,5 m ³ (33.36 cu.yd)		28 m ³ (36.6 cu.yd)																																															
SAE 1:1 Capacity	31 m ³ (40.55 cu.yd)		34 m ³ (44.5 cu.yd)																																															
SAE 2:1 Capacity with Autogate	26,5 m ³ (34.67 cu.yd)		29,5 m ³ (38.6 cu.yd)																																															
Rated Payload	41 000 kg (90.388 lbs)		45 400 kg (100.090 lbs)																																															
CAB	ROPS/FOPS certified		ROPS/FOPS certified																																															
	74 dBA internal sound level measured according to ISO 6396		74 dBA internal sound level measured according to ISO 6396																																															
OPTION WEIGHTS																																																		
Bin liner	1,626 kg		1,740 kg																																															
Tailgate	936 kg		998 kg																																															
Extra wheelset	937 kg		1,031 kg																																															

B45D

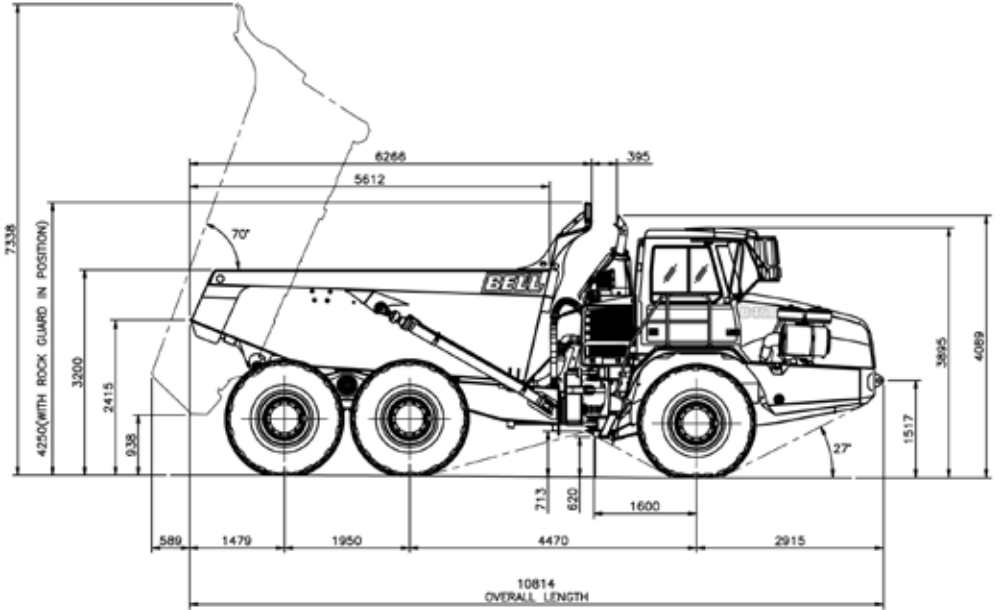
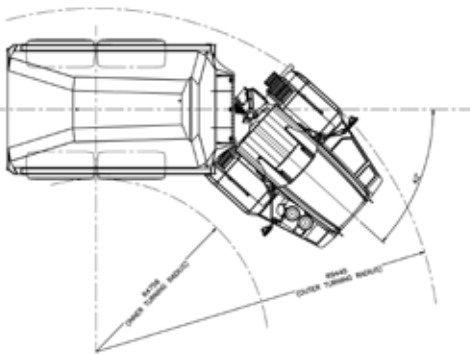
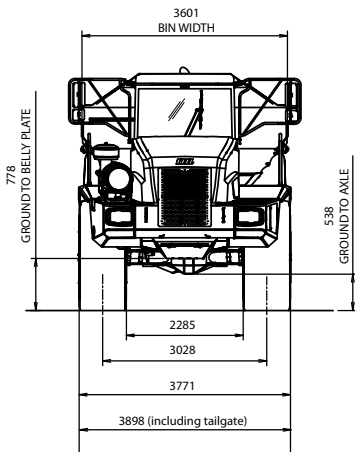

GRADEABILITY

1. Determine tractive resistance by finding intersection of vehicle mass line and grade line. NOTE: 2% typical rolling resistance is already assumed in chart and grade line.
2. From this intersection, move straight left across charts until line intersects rimpull curve.
3. Read down from this point to determine maximum speed attained at that tractive resistance.

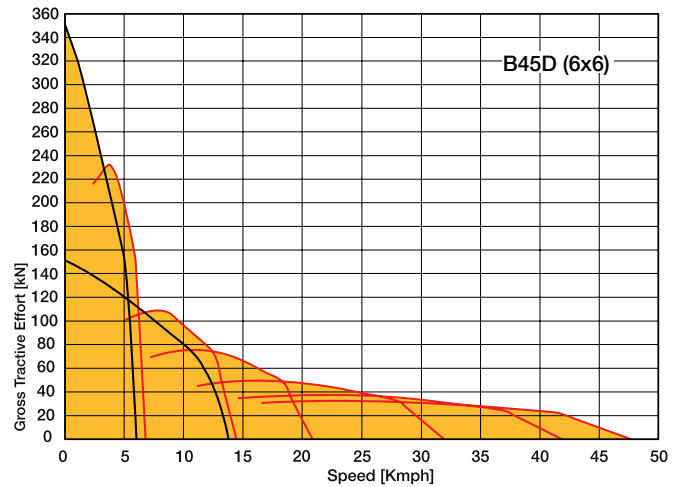
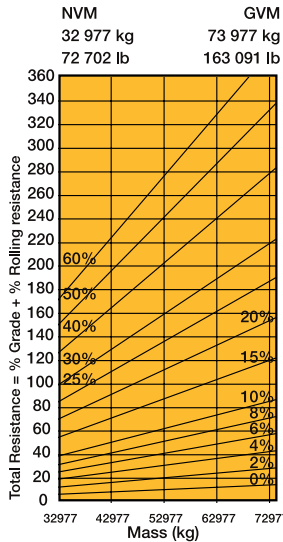

RETARDATION

1. Determine retardation force required by finding intersection of vehicle mass line.
2. From this intersection, move straight left across charts until line intersects the curve. NOTE: 2% typical rolling resistance is already assumed in chart.
3. Read down from this point to determine maximum speed.

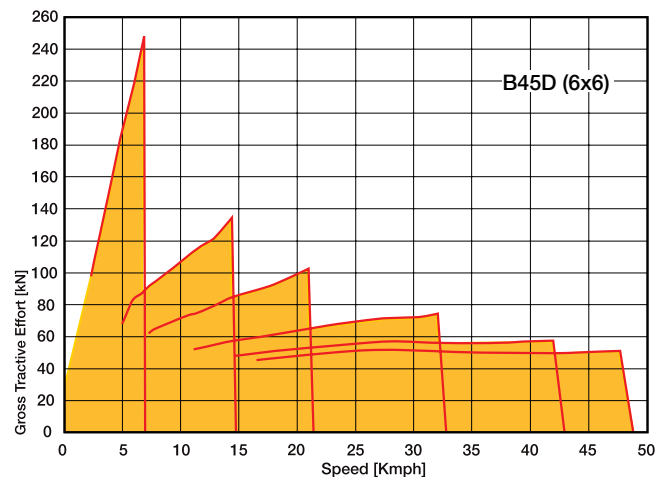
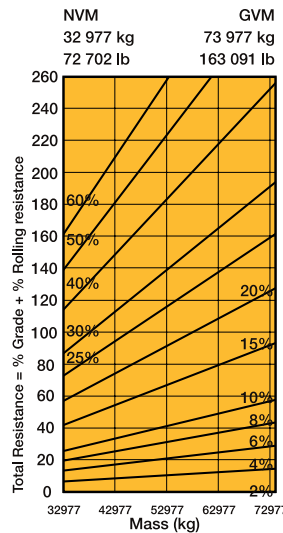

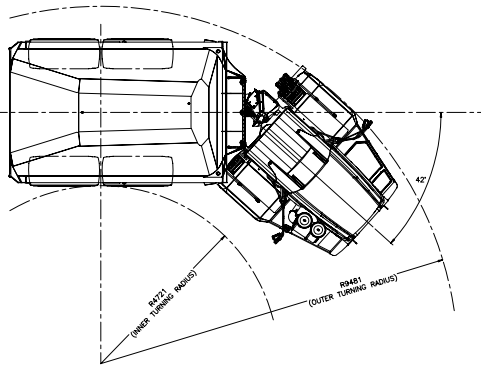
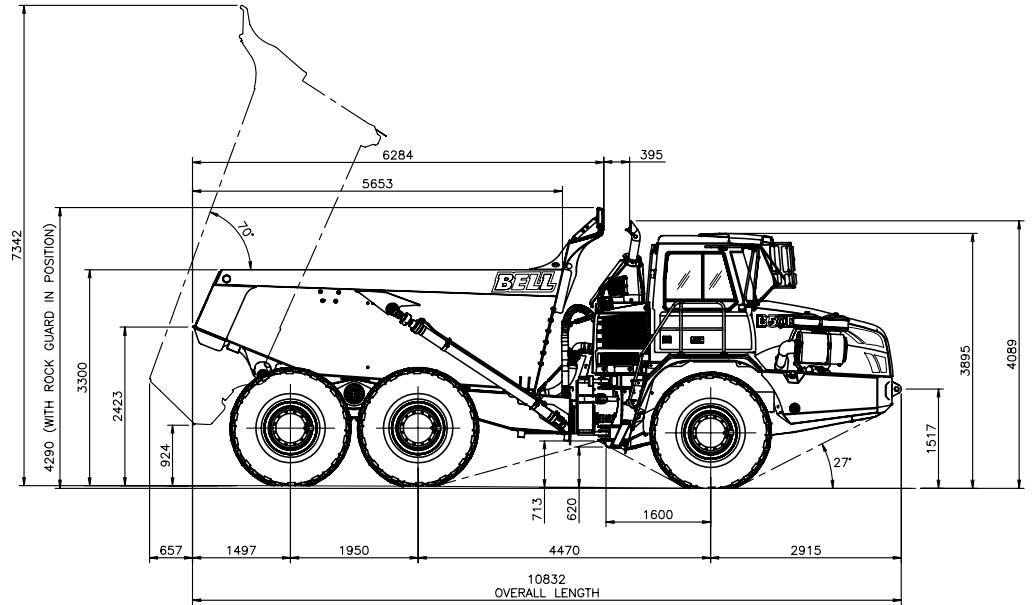
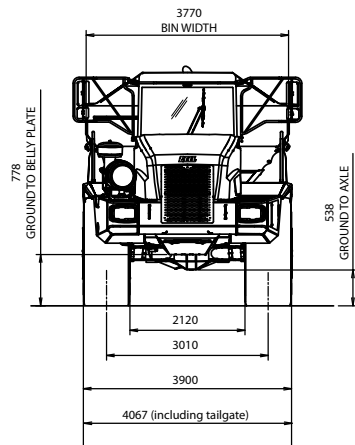

GRADEABILITY

1. Determine tractive resistance by finding intersection of vehicle mass line and grade line. NOTE: 2% typical rolling resistance is already assumed in chart and grade line.
2. From this intersection, move straight left across charts until line intersects rimpull curve.
3. Read down from this point to determine maximum speed attained at that tractive resistance.

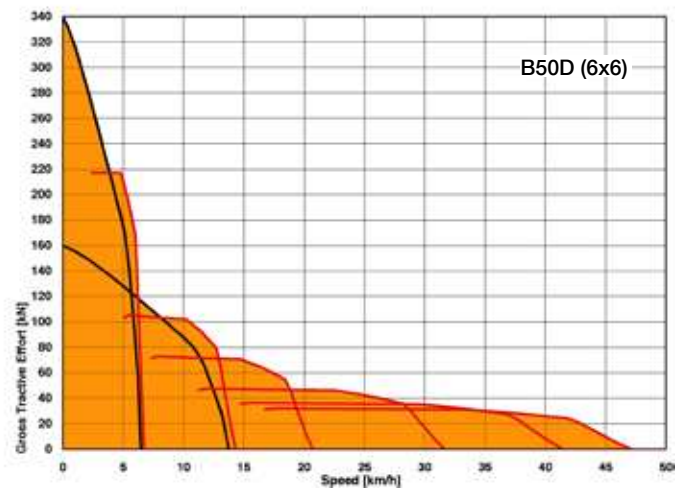
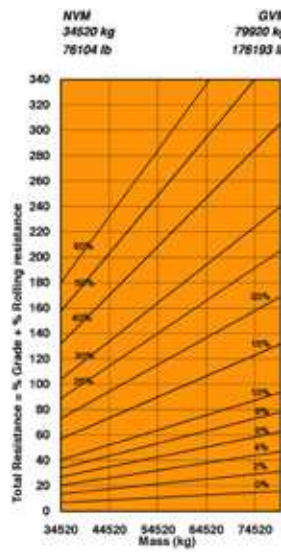

RETARDATION

1. Determine retardation force required by finding intersection of vehicle mass line.
2. From this intersection, move straight left across charts until line intersects the curve. NOTE: 2% typical rolling resistance is already assumed in chart.
3. Read down from this point to determine maximum speed.

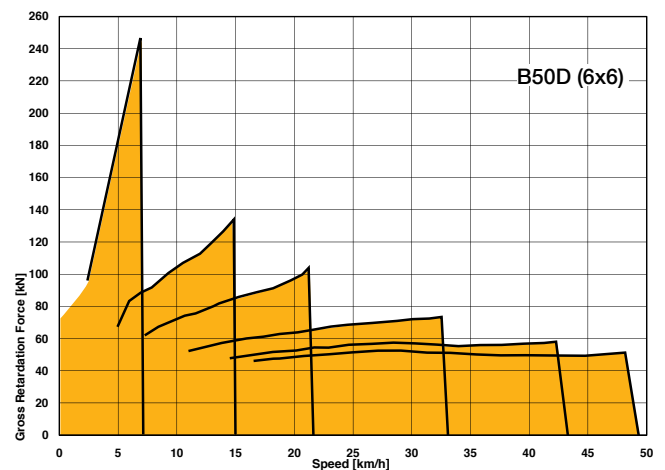
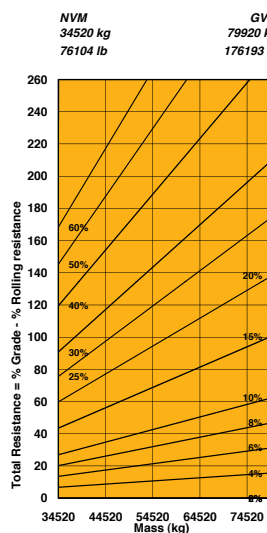



Features and Options

	B25D	B30D	B35D	B40D	B45D	B50D	
							● Standard ▲ Option
Engine							
●	●	●	●	●	●	●	Wet-sleeve cylinder liners
●	●	●	●	●	●	●	Engine valve brake and exhaust brake
●	●	●	●	●	●	●	Dual-element air cleaner with dust ejector valve
●	●	●	●	●	●	●	Precleaner
●	●	●	●	●	●	●	Water separator
●	●	●	●	●	●	●	Provision for fast fill
●	●	●	●	●	●	●	Serpentine drive belt with automatic tensioner
Cooling							
●	●	●	●	●	●	●	Crankshaft-mounted viscous-drive fan
		●	●	●	●	●	Remote proportionally controlled hydraulic Fan drive
●	●	●	●	●	●	●	Fan guard
Pneumatic System							
●	●	●	●	●	●	●	Engine-mounted compressor
●	●	●	●	●	●	●	Air drier with heater
●	●	●	●	●	●	●	Integral unloader valve
Electrical System							
●	●	●	●	●	●	●	Battery disconnect
							Drive lights
▲	▲	▲	▲	●	●	●	Deluxe work lights
●	●	●	●	●	●	●	Electric Hooter
●	●	●	●	●	●	●	Air Horn
●	●	●	●	●	●	●	Reverse alarm
●	●	●	●	●	●	●	Rotating Beacon
●	●	●	●	●	●	●	Pitch Roll Sensor
Steering System							
●	●	●	●	●	●	●	Ground-driven secondary steering pump
Cab							
●	●	●	●	●	●	●	ROPS/FOPS certification
●	●	●	●	●	●	●	Tilt cab
●	●	●	●	●	●	●	Gas strut-supported door
●	●	●	●	●	●	●	I-Tip programmable dump-body tip settings
●	●	●	●	●	●	●	Air conditioner
●	●	●	●	●	●	●	Heater
●	●	●	●	●	●	●	AM/FM radio/CD player
●	●	●	●	●	●	●	Rear window guard
●	●	●	●	●	●	●	Wiper/washer with intermittent control
●	●	●	●	●	●	●	Tilt and telescoping steering wheel
●	●	●	●	●	●	●	Centre-mount air-suspension seat
●	●	●	●	●	●	●	Rear window wiper

	B25D	B30D	B35D	B40D	B45D	B50D	
							● Standard ▲ Option
Cab (continued)							
●	●	●	●	●	●	●	Retractable seat belt
●	●	●	●	●	●	●	Foldaway trainer seat with retractable seat belt
●	●	●	●	●	●	●	12-volt power outlet
●	●	●	●	●	●	●	Cup holder
●	●	●	●	●	●	●	Cooled/heated lunch box
●	●	●	●	●	●	●	Ashtray
▲	●	▲	▲	●	●	●	Electric adjustable and heated mirrors
●	●	●	●	●	●	●	Deluxe monitor:
							Analog speedometer / Fuel gauge /
							Transmission oil temperature gauge /
							Engine coolant temperature gauge /
							LED function/warning indicators and audible
							alarm / Transmission gear selection /
							Tachometer / Battery voltage / Hour meter /
							Odometer / Fuel consumption / Tip counter /
							Trip timer / Trip distance / Metric/English units
							/ Service codes/diagnostics
							Backlit sealed switch module functions:
							Wiper control / Lights / Heated mirrors /
							Retarding aggressiveness / Controlled traction
							differentials (B35D/B40D/B50D) / Transfer case
							differential lock / Transmission gear hold /
							Dump-body tip limit / Automatic dump-body
							tip settings / Airconditioner/ Heater controls /
							Preselected Speed Control
Dump Body							
●	●	●	●	●	●	●	Dump-body mechanical lock
▲	▲	▲	▲	▲	▲	▲	Body liner
▲	▲	▲	▲	▲	▲	▲	Tailgate
▲	▲	▲	▲	▲	▲	▲	Body heater
▲	▲	▲	▲	▲	▲	▲	Less dump body and cylinders
Other							
●	●						23.5R25 radial earthmover tyres
		▲					750/65 R25
			●				26.5R25 radial earthmover tyres
				●		▲	29.5R25 radial earthmover tyres
					▲	●	875/65R29 radial earthmover tyres
●	●	●	●	●	●	●	Remote grease banks
▲	▲	▲	▲	●	●	●	Automatic greasing
●	●	●	●	●	●	●	Onboard Weighing
▲	▲	▲	▲	▲	▲	▲	Load lights
			▲	▲	▲	▲	Comfort Ride Suspension
●	●	●	●	●	●	●	Reverse Camera
▲	▲	▲	▲	▲	▲	▲	Hand Rails
▲	▲	▲	▲	▲	▲	▲	Tyre Pressure Monitoring
▲	▲	▲	▲	●	●	●	Cab Peak

BELL INTERNATIONAL : Tel: +27 (0) 35-907 9431

 Tel: +33 (0) 5 55 89 23 56

 Tel: +49 (0) 6631/ 91 13 - 0

 Tel: +34 91 879 60 19

 Tel: +27 (0) 11 928 9700

 Tel: +44 (0) 1283 712862

 Tel: +7 495 647 20 90

E-mail: sales@bellequipment.com • www.bellequipment.com

All dimensions are shown in millimetres, unless otherwise stated between brackets. Under our policy of continuous improvement, we reserve the right to change specifications and design without prior notice. Photographs featured in this brochure may include optional equipment.

BlueTec[®] is a registered trademark of Daimler AG
 Blu@dvantage[™] is a trademark of Bell Equipment Co. (PTY) Ltd
 AdBlue is a registered trademark of VDA

Strong Reliable Machines
Strong Reliable Support

BELL