

B35D 6x6 ARTICULATED DUMP TRUCK Mk VII

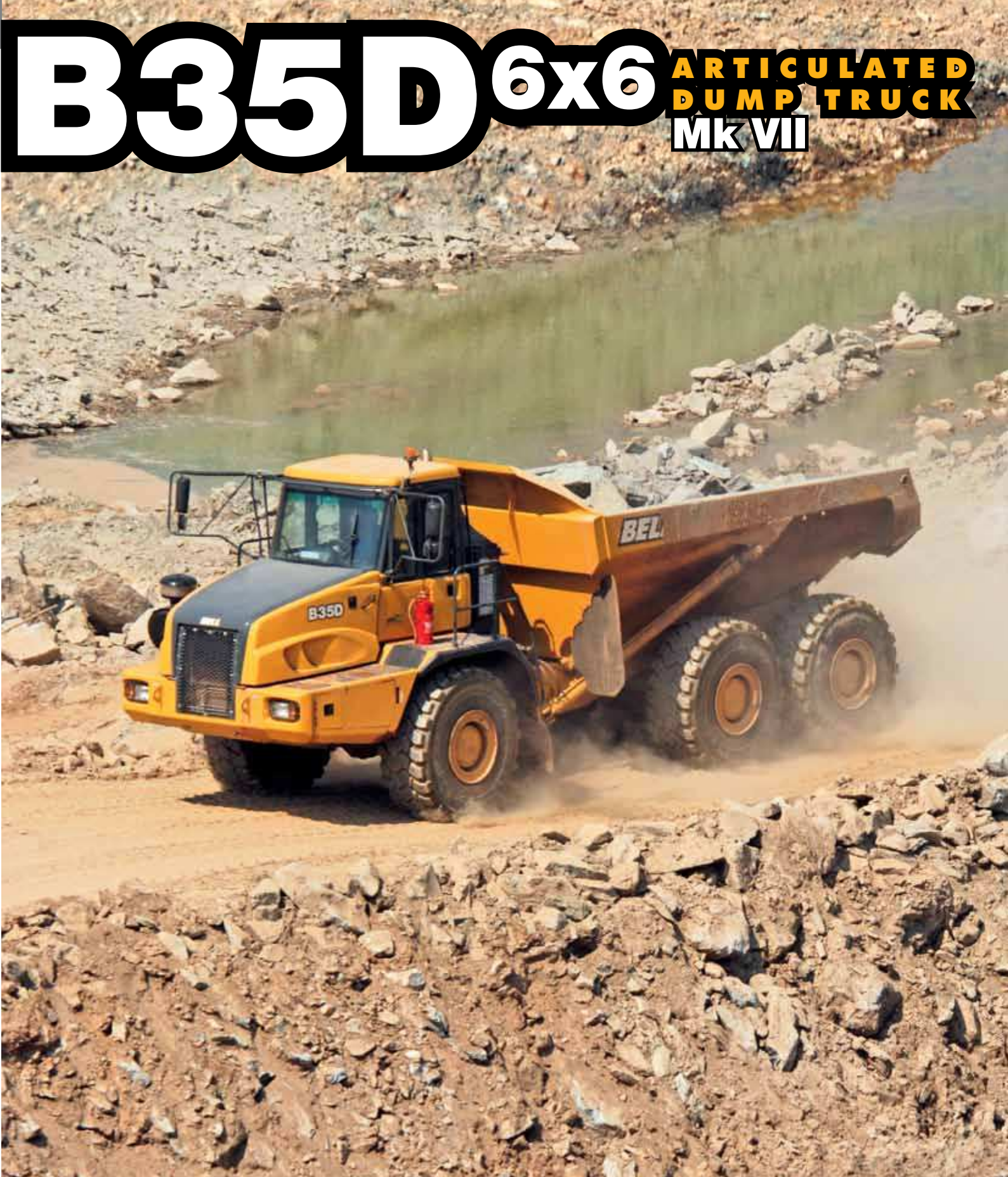

Blu@dvantage™

- Gross Power: 295 kW (402 hp)
- Gross Torque: 2 000 Nm (1,475 lbft)
- Rated Payload: 32 500 kg (71,650 lbs)

BELL

B35D 6x6 ARTICULATED DUMP TRUCK MKVII

ENGINE

Mercedes Benz V6, turbo-charged, intercooled, low emission diesel engine
Gross power 295 kW (402 hp) @ 1,800 rpm
Net Power 288 kW (390 hp) @ 1,800 rpm
Torque 2,000 Nm (1,475 lbft) @ 1,300 rpm
Displacement 11,95 litres (730 cu.in)
Fuel tank capacity 445 litres (118 US gal)
Auxiliary Brake Automatic exhaust brake Engine Valve Brake (EVB)
AdBlue Tank Capacity Certification 40 l (11 US gal) OM 501 LA meets Europe (EU) stage 3b emissions regulations

TRANSMISSION

Fully automatic Allison planetary transmission
Layout Engine mounted
Gear Layout Constant meshing planetary gears, clutch operated
Gears 6 Forward, 1 Reverse
Clutch type Hydraulically operated multi-disc
Control type Electronic
Torque Converter Hydrodynamic with lock-up in all gears

TRANSFER BOX

Remote mounted
Manufacturer Model Bell 17100
Layout Three in-line helical gears.
Output Differential Interaxle 33/67 proportional differential. Pneumatically lockable on the move.

AXLES

High strength steel fabricated with spiral bevel type gears on the Controlled Traction differential and heavy duty outboard planetary gears.
Model Bell 25T

BRAKING SYSTEM

SERVICE BRAKE Dual circuit, full hydraulic actuation wet disc brakes on front and middle axles.
Maximum brake force PARK & EMERGENCY 193 kN (43,388 lbf)
 Spring applied, air released driveline mounted disc.
Maximum brake force 440 kN (98,920 lbf)



AUXILIARY BRAKE

Automatic exhaust brake Engine Valve Brake (EVB)
 Variable Adjustable Hydraulic retarder
Maximum retardation 575 kW (771 hp)

WHEELS

Tyre Earthmover 26.5R25

FRONT SUSPENSION

Semi-independent, leading A-frame supported by nitrogen/oil struts.

REAR SUSPENSION

Pivoting walking beams equalise the load on each axle with laminated suspension blocks. Each axle is coupled to the chassis by a Tri-Link system of four rubber-bushed links for ideal vertical movement and a transverse link for lateral restraint.

HYDRAULIC SYSTEM

Variable displacement with load sensing system incorporating a ground driven emergency steering pump.
Flow 300 l/min (79,26 gal/min)
Pressure 25 Mpa (3,626 psi)
Filter 5 microns

STEERING SYSTEM

Hydrostatically actuated by two double acting cylinders, with ground-driven emergency steering pump.
Lock to lock turns 4.7
Steering Angle 42°

DUMPING SYSTEM

Two double-acting, single stage, dump cylinders
Raise Time 13 s
Lowering Time 7,6 s
Tipping Angle 70°

PNEUMATIC SYSTEM

Air drier with heater and integral unloader valve, serving park brake and auxiliary functions
System Pressure 810 kPa (117 psi)

ELECTRICAL SYSTEM

Voltage 24 V
Battery Type Two maintenance free permanently sealed
Battery Capacity 2 X 105 Ah
Alternator Rating 28 V 80 A

VEHICLE SPEEDS

1st	8 km/h
2nd	17 km/h
3rd	24 km/h
4th	37 km/h
5th	48 km/h
6th	54 km/h
R	6,3 km/h



B35D 6x6 ARTICULATED DUMPTRUCK Mk VII

LOAD CAPACITY & GROUND PRESSURE

WEIGHTS			GROUND PRESSURE		LOAD CAPACITY			OPTION WEIGHTS	
UNLADEN	kg	lbs	LADEN (No sinkage)	kPa	BODY	m ³	cu.yd		kg
Front	14,120	31,129	Front	303	Struck Capacity	16	20,9	Bin liner	1,360
Middle	7,060	15,565	Middle	338	SAE 2:1 Capacity	20,5	26,8	Tailgate	804
Rear	7,050	15,543	Rear	338	SAE 1:1 Capacity	24,5	32	Extra wheelset	714
Total	28,230	62,236			SAE 2:1 Capacity with Autogate	21	27,4		
LADEN			LADEN (With sinkage)						
Front	18,350	40,455	Front	159					
Middle	21,195	46,727	Middle	177	Rated Payload	32 500kg (71,650 lbs)			
Rear	21,185	46,705	Rear	177					
Total	60,730	133,887							

GRADEABILITY/RIMPULL

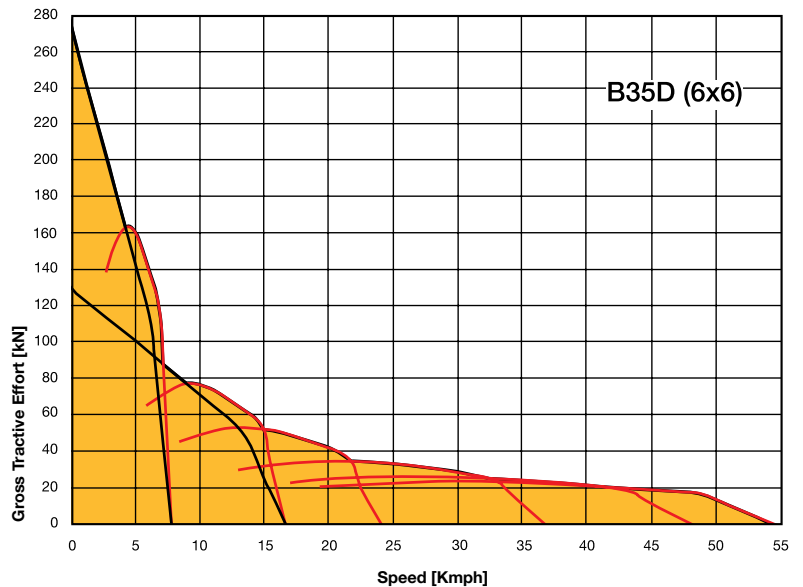
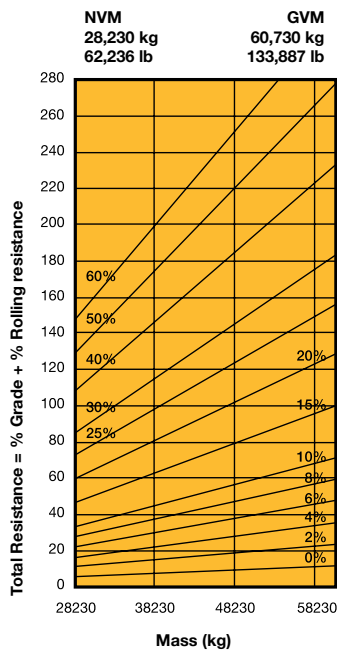

RETARDATION

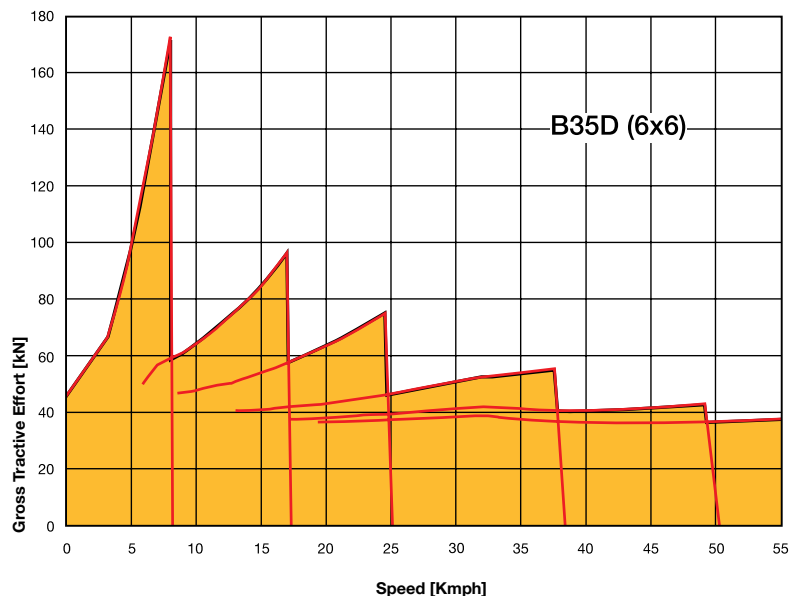
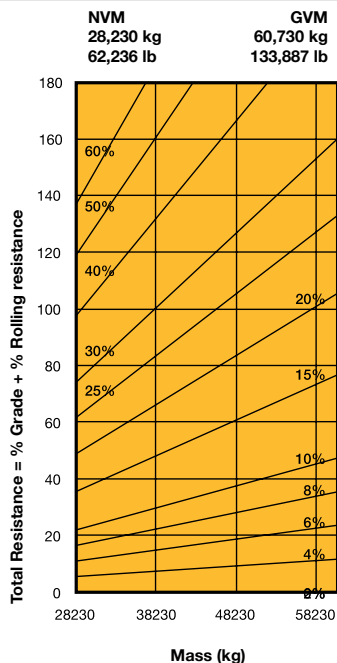

B35D 6x6 ARTICULATED DUMP TRUCK MkVII

DIMENSIONS

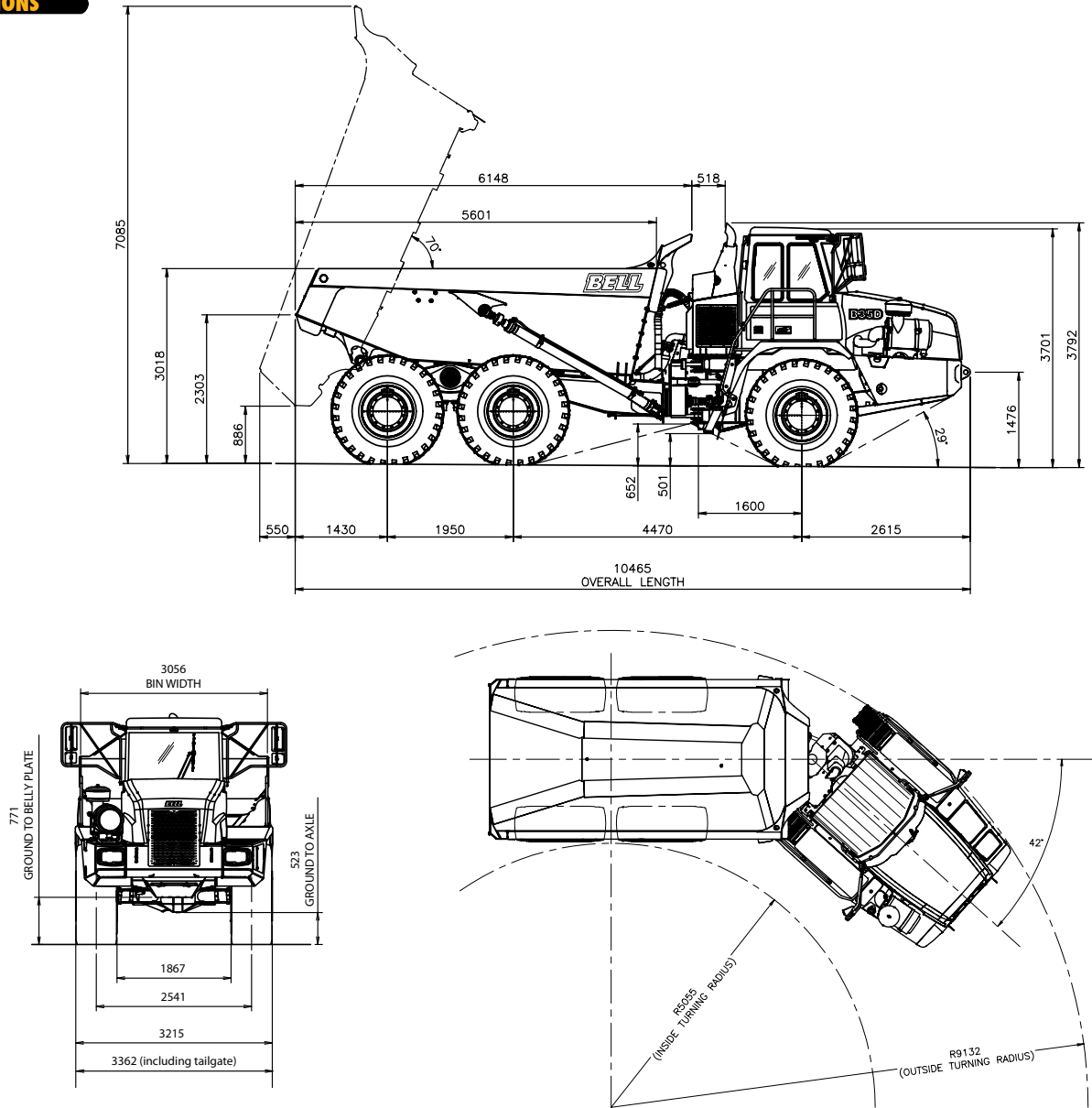

B35D 6x6 ARTICULATED DUMP TRUCK MKVII

AVAILABLE EQUIPMENT*

Cab

- ROPS/FOPS certification
- Protective rear window guard
- Tilt cab for service access
- Gas strut supported door
- Tinted safety glass
- Sliding windows
- Rear view mirrors- regular and wide angle
- Electrically adjustable rearview mirrors - one per side
- Sun visor
- Wiper/washer with intermittent control
- Tilt and telescoping steering wheel
- Adjustable, air suspension seat with retractable seat belt
- Fold-away trainer seat with retractable seat belt
- HVAC climate control system with filtered and ducted air
- Rotating beacon
- 12 V power outlet/12 V cigarette lighter
- Ash tray
- Drinks holder
- Cooled/heated lunch box
- I-Tip programmable bin tip
- Sound insulated to 76 dB(A) to ISO 6396
- Radio/CD/Tape
- Memory Module
- Air horn

MDU Features

- Operator / Site selected speed control
- Tipping counter
- Trip timer
- Trip distance
- On Board Weigh System (OBW)
- Transmission gear selection
- Fuel Consumption
- Diagnostics
- Intermittent wiper timing control
- Speedo calibration for alternative tyre sizes
- Metric /Imperial unit selection
- Warning lights with audible buzzer

Gauges

- Engine coolant temperature
- Engine oil pressure
- Transmission oil temperature
- Fuel
- Tachometer
- Battery voltage
- Hourmeter
- Odometer
- System air pressure

Vehicle

- Ground driven emergency steering
- Bin safety prop
- Articulation lock
- Integral transmission output retarder with 6 settings

Other

- (Factory or field installed)
- Groeneveld auto greasing system
 - Retractable sun visor
 - Exhaust body heating
 - Autogate
 - Body liners
 - Fleetmatic Satellite Monitoring System
 - Driver ID and immobiliser
 - Forward working lights
 - Artic reverse light
 - Fuel heater
 - External windshield visor
 - Headlight protection grills
 - Rear window wiper
 - Antenna mounting bracket
 - System for reverse camera
 - Wiggins quick fuelling system
 - Tyre pressure monitoring

*standard specification for machines may vary according to region



B35D 6x6 ARTICULATED DUMP TRUCK Mk VII

- The exclusive on-board weighing option presents the operator with real time information on the payload while the machine is being loaded. A 'limp home' mode can also be activated if the machine is significantly over-loaded.



- The park brake automatically applies when neutral is selected and it is not possible to engage neutral at speed. Torque dependent park brake release (hill assist) ensures no roll back on slopes.



- The incorporation of a Pitch and Roll sensor in the vehicle allows the bin to not be operated if the truck is in an unsafe position.



- Full hand-rails kit can be installed to provide even more safety when performing engine checks.



- Keyless start, driver identity, and access codes ensures no unauthorized operation of your equipment.



- Both operator or site selectable maximum speed control allows the vehicle to automatically de-accelerate and apply the retarder to prevent onsite speeding.



- Reverse cameras are available for factory or on site fitment ensuring full view when reversing.



- Optional Tyre pressure - monitoring System ensures that the operator has real time information on all tyres pressure and temperature conditions.



- The best in class retarder and engine braking automatically applies when the operator lifts his foot off the accelerator. Retarder aggressiveness can be simply adjusted on the sealed switch module ensuring maximum descent control for all conditions.

- All trucks can be set up to automatically sound the horn when starting or switching between forward and reverse.

BELL INTERNATIONAL: Tel: +27 (0) 35-907 9431

 Tel: +33 (0) 5 55 89 23 56

 Tel: +49 (0) 6631 / 91 13 - 0

 Tel: +34 91 879 60 19

 Tel: +27 (0) 11-928-9700

 Tel: +44 (0) 1283 712862

 Tel: +7 495 647 20 90

E-mail: sales@bellequipment.com

• www.bellequipment.com

All dimensions are shown in millimetres, unless otherwise stated between brackets.
Under our policy of continuous improvement, we reserve the right to change specifications and design without prior notice. Photographs featured in this brochure may include optional equipment.

**Strong Reliable Machines
Strong Reliable Support**