

D-series

MkVII

Articulated Dump Trucks

B35D | B40D | B45D | B50D



Blu@dvantage™

BELL

Courtesy of Machine.Market

Get more **from** your **truck**

If you're looking to deliver more to your bottom line, choose Bell Articulated Dump Trucks.

These D-series ADTs handle heaped payloads with faster cycle times and best-in-class fuel efficiency - so you'll move more material at lower cost. They're highly reliable too, with high-strength, welded-alloy steel chassis and components that are durable and optimised to reduce unnecessary weight. And with their oscillating frame joint, articulated steering and high-floatation tyres, these hard working haulers won't let wet weather or steep grades dampen your plans.

- Extensive use of high-strength, lightweight materials gives these trucks the best payload-to-mass ratios and hauling efficiencies in each class.
- With their oscillating frame and high-floatation tyres, Bell trucks won't leave you stuck on muddy, rutted or hilly terrain.
- The redesigned sound-suppressed cab features fatigue-beating controls, advanced diagnostic monitor and a sealed-switch module for convenient, fingertip operation of numerous functions.
- Fuel-efficient emission-certified engines deliver clean power without compromise in all conditions. Leading-edge emissions technology ensures rapid engine response and dependable cold-start performance.



Specifications	B35D	B40D	B45D	B50D
Gross power	295 kW (396 hp)	335 kW (449 hp)	375 kW (503 hp)	375 kW (503 hp)
Operating mass				
Unladen	28 230 kg (62 236 lb)	29 850 kg (65 808 lb)	32 980 kg (72 708 lb)	34 520 kg (76 104 lb)
Laden	60 730 kg (133 887 lb)	66 851 kg (147 381)	73 980 kg (163 098 lb)	79 920 kg (176 193 lb)
2:1 heaped capacity	20,5 m ³ (27 yd ³)	23 m ³ (30 yd ³)	25,5 m ³ (33,5 yd ³)	28 m ³ (37 yd ³)
Rated payload	32 500 kg (71 650 lb)	37 000 kg (81 571 lb)	41 000 kg (90 390 lb)	45 400 kg (100 090 lb)



Enhancements such as industry leading standards in fuel-efficient emission control, solid state electrical system, spacious cab with refined controls and you have everything you need to maximise uptime and productivity.

Haul of Fame



Transfer case inter-axle differential delivers equal torque to each axle when traction is favourable. When conditions get ugly, engage the diff-lock on the go to deliver torque to the tyres that can best use it.



The central oscillation joint, high suspension travel on all axles, and balanced weight distribution provide the agility and ability to navigate hostile terrain.



Front-suspension damping helps minimise vibration, while the centre-mounted seat reduces the roll often experienced in off-road conditions - for comfortable productivity.



Optional tailgate is available for better material retention. The tailgate opens as the bin is raised for dumping. Tie-down straps maintain positive seal throughout haul, ensuring minimal material is lost.



• The best-in-class payload-to-weight ratio means that more of your fuel cost is spent moving the material, not the machine - decreasing your cost per tonne.

• Automatic retardation slows the truck when the operator backs off the accelerator pedal - for more confidence on steep grades and enhanced brake life.

• An industry leading, fully automatic six-speed planetary transmission with torque converter lock up maximises fuel efficiency.

• Electronic unit injection fuel system provides high injection pressures even at low engine speed for improved cold-starting ability, low-speed response, and reduced emissions.

• Controlled Traction Differentials (CTD) and automatic Inter-axle Differential Lock (IDL) provide Automatic Traction Control (ATC) in poor underfoot conditions.

• High-travel suspension keeps all tyres in constant ground contact for optimum traction.



Bell ADTs give you the competitive edge. Boasting faster haul cycles and industry-leading fuel economy, they move material at the lowest cost per tonne of any comparable-size truck. Best in-class payload-to-mass ratio gives you more power and agility to carry the load, for maximum productivity and profitability. What really sets these apart from other material movers is their ability to thrive on rough terrain, steep grades and mud. Try one to appreciate the difference.

Nothing's built as strong as a Bell

Built smarter to work harder, these lean machines boast the material-moving muscle you need without the mass to feed.

Their lower mass reduces powertrain and structural stress. Other uptime-boosting features include enhanced diagnostics, solid-state sealed switches and re-inforced articulation joints to list but a few. When you know how they're built, you'll run a Bell.



Planetary powershift transmission optimises shift points and protects the transmission from operator error and abuse. Thicker clutch plates, generous lubrication flow, and heavy-duty cooling ensure long life.



High-strength steel and widely spaced taper roller bearings in the articulation area enhance long-term durability.



The high-strength steel chassis delivers strength and rigidity without excess weight.

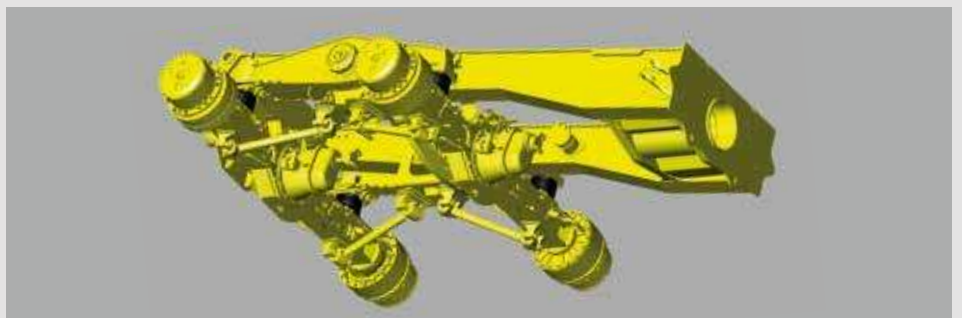

Rough terrain demands tough suspensions. Heavy-duty components absorb shocks and come back for more. You get best-in-class ground clearance, too.



- Efficient viscous direct-drive engine fans in all Bell trucks provide engine and charge-air cooling.

- Fully enclosed, dual circuit wet disc brakes offer superior braking performance and extended service life essential for wet and muddy conditions. Oil-immersed wet-disc brakes are virtually maintenance-free.

- Class leading engine braking coupled with automated transmission retardation provides superior braking power and reduces service brake wear.

- Hydraulic, transmission and transfer case oil coolers employ a hydraulically driven fan that runs only as needed or when engine loading is low, helping conserve power and fuel.

- Intelligent traction control provides superior traction in poor underfoot conditions.

Bringing you tomorrow's technology today

A combination of an optimally tuned engine and weight optimised complete machine package ensure that Bell ADTs have a minimal carbon footprint.

Blu@dvantage™

- AdBlue® is non-toxic, odourless, low cost and simple to refill.
- AdBlue® is injected into the flow of the exhaust gases and reacts with the NOx gases in the catalytic convertor to form harmless Nitrogen and water.
- Field tests on the new Blu@dvantage™ system show up to 15% saving in fuel over previous Bell ADTs.
- AdBlue® usage is approximately 3-5% of your fuel usage.

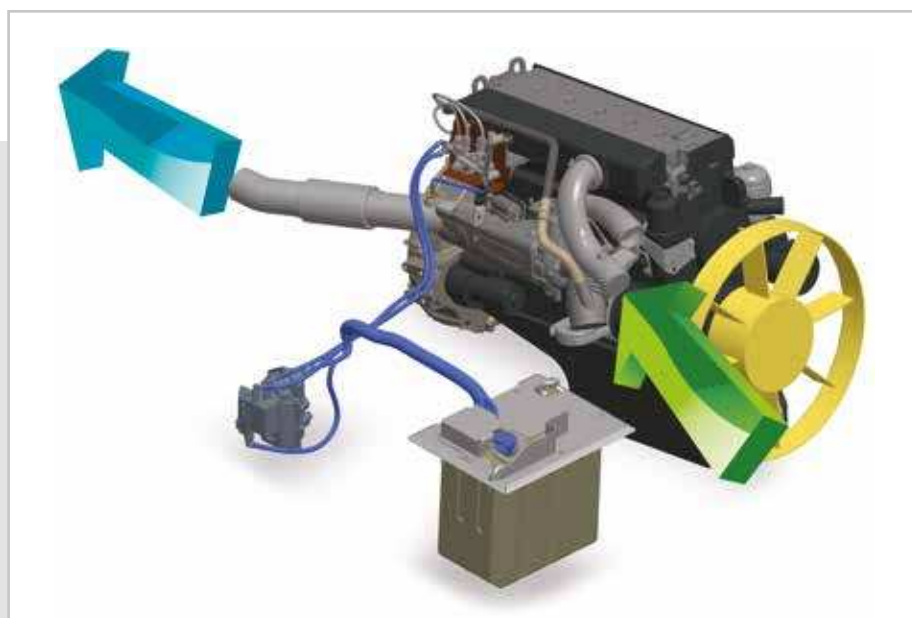

- Reduced emissions
- Improved engine efficiency
- Lower fuel consumption
- Improved power
- Improved torque
- Improved engine response



Bell Equipment is an industry leader in fuel-efficient emission control with the introduction of SCR-technology (Selective Catalytic Reduction) to be compliant to Stage IIIB & Tier 4i emission standards. Called Bell Blu@dvantage™, it is an SCR package designed specifically for the off-highway market.

With SCR technology customers are able to reduce harmful Nitrogen Oxides while being able to save on fuel. So Blu@dvantage™ is not just healthy for the environment; it's healthy for your wallet too.



Built for Comfort

What operator wouldn't want to climb behind the wheel of a Bell ADT?

It's spacious, quiet, climate-controlled cab is loaded with productivity-boosting comfort and convenience features that rival some SUVs.

From the state-of-the-art multifunction monitor and fully customisable controls to air-suspension seat, tilt/telescoping steering wheel and optional CD player with high-output speakers, the D-series provides everything your operators need to perform at their best. Unparalleled comfort.

Our innovative Comfort Ride System...

...is available as an option to even further enhance ride comfort by ensuring minimal whole body vibration exposure. Productivity increases, through reduced cycle times and reduced haul road maintenance are even further benefits. The adaptive front suspension is standard on the B45D and B50D and an option on the B35D and B40D. The rear suspension is an option on all machines and long haul cycles with rough, hard roads will see the maximum benefits of this simple but extremely successful system, especially on the unladen run.



- An intuitive monitor reveals vital operating information, detailed diagnostic readings of sensors and switches and dump body function settings.



- Convenient sealed switch module provides fingertip control of numerous productivity enhancing functions including: **Dump body upper limit, Soft stop / hard stop selection, I-Tip and Speed Control.**



- Who says you can't take it with you? There's a place for a coffee cup, in-door storage for an insulated flask or other carry-ons, and even a hot/cold box for refreshments.



- Easy-to-understand instruments and intuitive controls wrap around the operator so they're easier to view and operate.

- A fully adjustable air-suspension seat is optimally positioned behind the front axle to help smooth out the ride when the going gets rough.

- You won't find retarder pedals or levers in a Bell truck. Retarder aggressiveness is simply set on the switch pad. Everything else is automatic.

- The adaptive transmission control adjusts clutch engagement to ensure smooth, consistent shifts throughout the life of the truck.

- A heavy-duty bi-level climate-control system with automotive-style louvres keeps the glass clear and cab comfortable.

- The spacious suspension seat and a comprehensive mirror package provide exceptional all-around visibility.

- The standard sound-suppression package significantly reduces noise levels and operator fatigue.

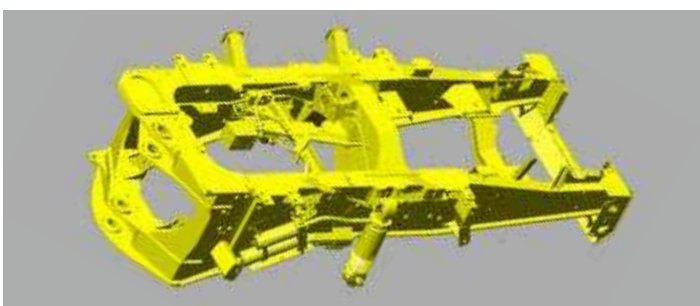

The front suspension consists of an A-frame layout, supported by two independent hydro-pneumatic suspension struts. The spring rate and damping is optimally tuned for a perfect combination of machine comfort and safe handling experience.

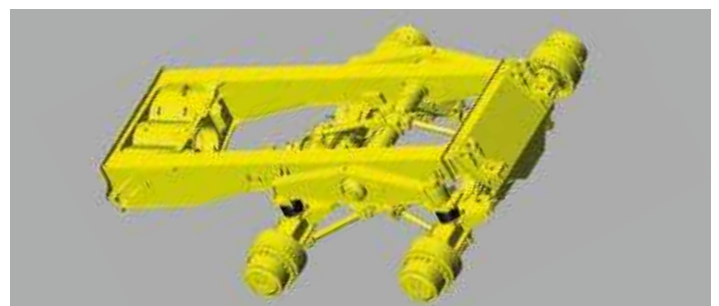

The Comfort-Ride option offers dual stage rubber blocks, which change the suspension characteristics to best match the laden and unladen haul cycles to maximise operator comfort.

Safety is our Business too



The exclusive on-board weighing presents the operator with real time information on the payload while the machine is being loaded. A 'speed restriction' mode can also be activated if the machine is significantly over-loaded.



The park brake automatically applies when neutral is selected and it is not possible to engage neutral at speed. Torque dependent park brake release (Hill Assist) ensures no roll back on slopes.



Business

By listening to our customers and reacting quicker to a changing workplace we provide a vehicle that exceeds application safety standards.



• The best in class retarder and engine braking automatically applies when the operator lifts his foot off the accelerator. Retarder aggressiveness can be simply adjusted on the sealed switch module ensuring maximum descent control for all conditions.

• All trucks can be set up to automatically sound the horn when starting or switching between forward and reverse.

• Keyless start, driver identity, and access codes ensures no unauthorized operation of your equipment.



• The incorporation of a Pitch and Roll sensor in the vehicle allows the bin to not be operated if the truck is in an unsafe position.



• Both operator or site selectable maximum speed control allows the vehicle to automatically de-accelerate and apply the retarder to prevent onsite speeding.



• Our quiet operator cabins are ROPS/FOPS certified with air suspension operator seat. Both operator and trainer seat have retractable lap belts with automatically locking retractors.



• Reverse cameras are available for factory or on site fitment ensuring full view when reversing.



• Full hand-rails (to ISO 2876) can be installed to provide even more safety when performing engine checks.



Here's the lowdown daily operating costs

You won't have to dig deep to uncover the many ways we've simplified service and made the D-series less expensive to maintain.

Easy-to-reach dipsticks, see-through reservoirs, sight gauges and grouped service points make quick work of the daily routine. High-hour oil and filter change intervals reduce costs and planned downtime. Quick-change filters and extended engine and hydraulic oil-service intervals reduce costs and provide more uptime. Plus, an advanced diagnostic monitor and diagnostic test ports help you troubleshoot problems and make informed maintenance decisions.

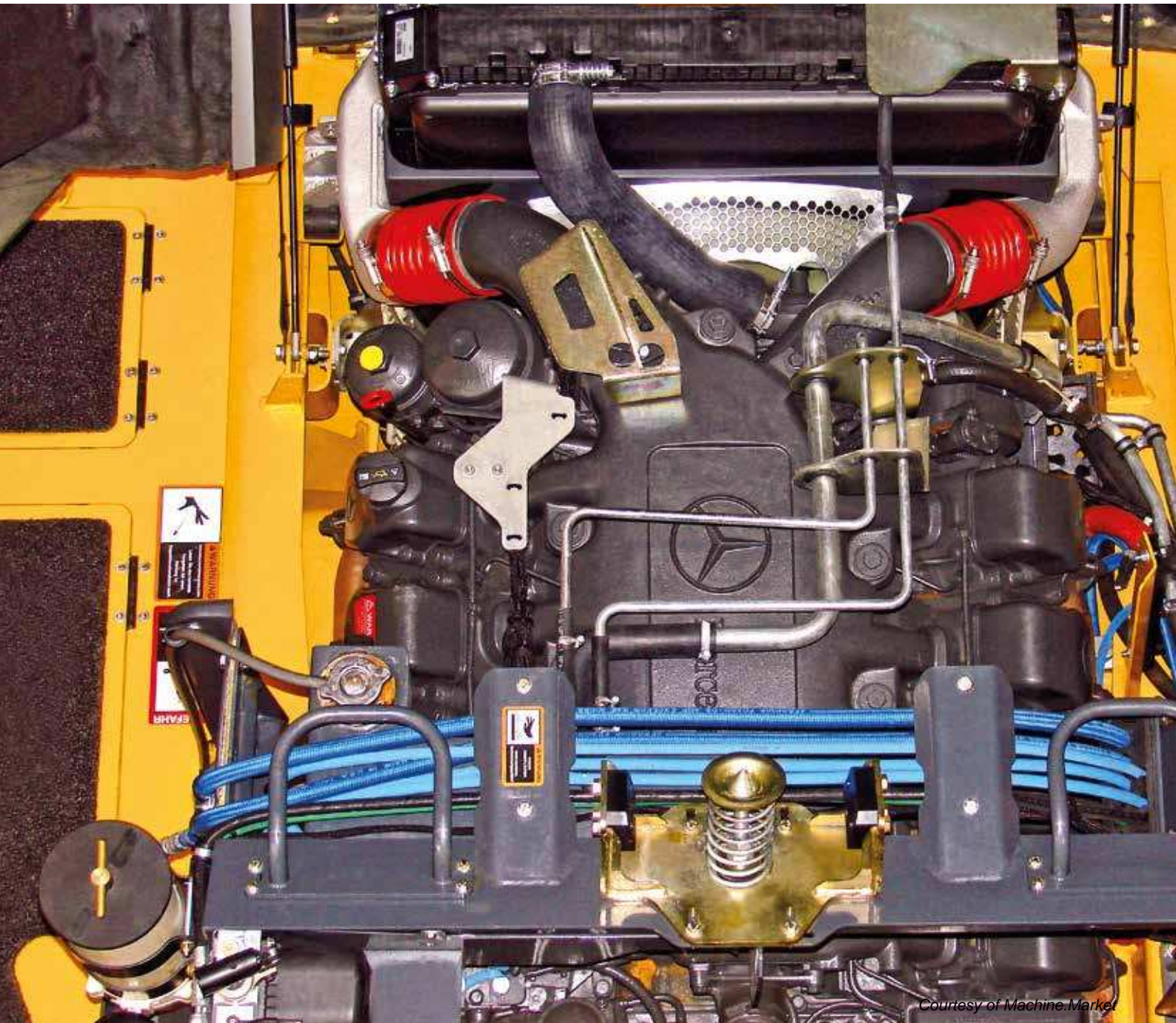

own on osts

- If something goes wrong, the diagnostic monitor provides service codes and supporting info to help you quickly pinpoint the problem.



- The cab can be tilted without special tools in minutes, for convenient service access to drivetrain components.



- The load-sensing hydraulic system was designed with simplicity in mind while maintaining efficiency. Fewer components result in greater reliability and service ease.

- Extended engine transmission and hydraulic oil-change for increased uptime and lower operating cost.

- The engine dipstick and oil fill, oil and fuel filters and coolant reservoir are readily accessible.

- Available environmental drains allow quick, no-spill changes.

- Your Bell Service Centre has the parts and backup you need to stay productive and offers a wide variety of preventative maintenance and support programmes to help you control costs.

- An in-cab load centre simplifies fuse replacement. Fewer relays, connectors and harnesses mean higher reliability.



- See-through fluid reservoirs and sight gauges let you check fluid levels at a glance.



- Easily accessible test ports allow technicians to troubleshoot problems more quickly.



- The centralised lube bank places difficult-to-reach nipples within reach for easy access. The convenient lube chart helps ensure that nothing gets overlooked.



Where ever you are...

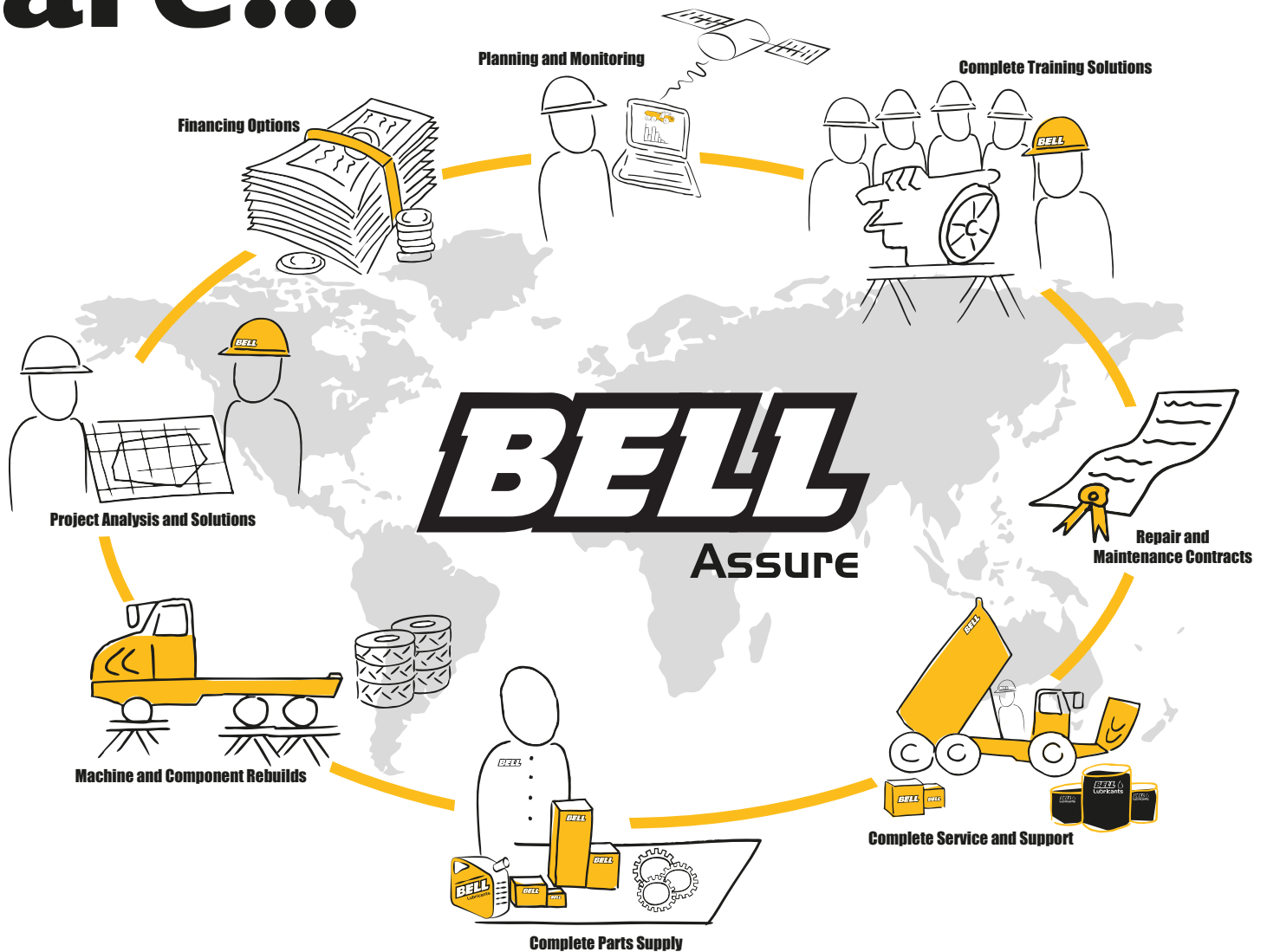

Through our own network as well as approved dealers and strategic alliances we ensure supply and support to the global market.

Develop a lasting and meaningful partnership with Bell Equipment through Bell Assure, your tailor-made support structure furnished with all the after-sales tools you need to give you best value, peace of mind and a unique after-sales experience.

...we have you covered

Smarter fleet management



BELL
Fleetm@tic

Cutting edge technology, helping you run your fleet smarter. Providing accurate, up-to-date operational data, production data and diagnostic data.

Machine operational data is processed and compiled into useful production and performance statistics, accessible via the Bell Fleetm@tic website. These reports are also automated and emailed directly to you. The key to a productive and profitable fleet, lies in the ability to monitor and manage your machines and operators efficiently.

Fleetm@tic:

- Maximise productivity
- Generate machine utilisation reports
- Identify operator training requirements
- Pro-active maintenance planning
- Receive machine health data
- Implement safety features
- Protect investments
- Receive real time geospatial data

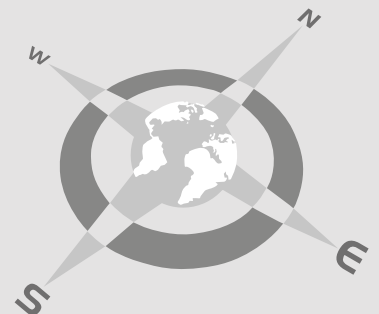

Technical Data - B35D

ENGINE

Mercedes Benz V6, turbocharged, intercooled, low emission diesel engine.

Gross Power

295 kW (396 hp) @ 1 800 rpm

Net Power

288 kW (386 hp) @ 1 800 rpm

Torque

2 000 Nm (1 475 lbf) @ 1 300 rpm

Displacement

11,95 litres (729 cu.in)

Fuel Tank Capacity

445 litres (118 US gal)

Auxiliary Brake

Automatic exhaust brake
Engine Valve Brake (EVB)

AdBlue® Tank Capacity

40 l (11 US gal)

Certification

OM 501 LA meets EU Stage IIIB/EPA Tier 4i emissions regulations.

TRANSMISSION

Fully automatic Allison planetary transmission.

Layout

Engine mounted

Gear Layout

Constant meshing planetary gears, clutch operated.

Gears

6 Forward, 1 Reverse

Clutch Type

Hydraulically operated multi-disc

Control Type

Electronic

Torque Control

Hydrodynamic, with lock-up in all gears.

TRANSFER BOX

Remote mounted

Manufacturer

Bell VGR

Model

17 100

Layout

Three in-line helical gears

Output Differential

Interaxle 33/67 proportional differential, Pneumatically lockable on the move.

AXLES

High strength steel fabricated with spiral bevel type gears on the Controlled Traction differential and heavy duty outboard planetary gears.

Model

Bell 25T

BRAKING SYSTEM

Service Brake

Dual circuit, full hydraulic actuation wet disc brakes on front and middle axles.

Maximum Brake Force

278 kN (62 344 lbf)

Park & Emergency

Spring applied, air released driveline mounted disc.

Maximum Brake Force

440 kN (98 920 lbf)

Auxilliary Brake

Automatic exhaust brake
Engine Valve Brake (EVB)
Adjustable Hydraulic retarder.

Maximum Retardation

721 kW (967 hp)

WHEELS

Type

Radial Earthmover

Tyre

26.5R25

FRONT SUSPENSION

Semi-independent, leading A-frame supported by hydro-pneumatic suspension struts.

REAR SUSPENSION

Pivoting walking beams with laminated rubber suspension blocks.

HYDRAULIC SYSTEM

Variable displacement with load sensing system incorporating a ground driven emergency steering pump.

Flow

300 l/min (79,26 US gal/min)

Pressure

25 Mpa (3 626 psi)

Filter

5 microns

STEERING SYSTEM

Hydrostatically actuated by two double acting cylinders, with ground-driven emergency steering pump.

Lock to lock turns

4,7

Steering Angle

42°

DUMPING SYSTEM

Two double-acting, single stage, dump cylinders.

Raise Time

13 s

Lowering Time

7,6 s

Tipping Angle

70°

PNEUMATIC SYSTEM

Air drier with heater and integral unloader valve, serving park brake and auxiliary functions.

System Pressure

810 kPa (117 psi)

ELECTRICAL SYSTEM

Voltage

24 V

Battery Type

Two maintenance free permanently sealed.

Battery Capacity

2 X 105 Ah

Alternator Rating

28 V 80 A

VEHICLE SPEEDS

1st	8 km/h	5 mph
2nd	17 km/h	10,6 mph
3rd	24 km/h	15 mph
4th	37 km/h	23 mph
5th	48 km/h	30 mph
6th	54 km/h	33,8 mph
R	6,3 km/h	3,9 mph

CAB

ROPS/FOPS certified

75 dBA internal sound level measured according to ISO 6396.

Load Capacity & Ground Pressure

OPERATING WEIGHTS		GROUND PRESSURE		LOAD CAPACITY		OPTION WEIGHTS	
UNLADEN	kg (lb)	LADEN (No sinkage)	kPa (Psi)	BODY	m³ (yd³)		kg (lb)
Front	14 120 (31 129)	Front	306 (44)	Struck Capacity	16 (21)	Bin liner	1 119 (2 467)
Middle	7 060 (15 565)	Middle	336 (49)	SAE 2:1 Capacity	20,5 (27)	Tailgate	947 (2 088)
Rear	7 050 (15 543)	Rear	336 (49)	SAE 1:1 Capacity	24,5 (32)	Extra wheelset	714 (1 574)
Total	28 230 (62 236)			SAE 2:1 Capacity with Autogate	21 (27,5)		
LADEN		LADEN (With sinkage)					
Front	18 350 (40 455)	Front	196 (28)				
Middle	21 195 (46 727)	Middle	217 (31)	Rated Payload	32 500 kg		
Rear	21 185 (46 705)	Rear	217 (31)		(71 650 lb)		
Total	60 730 (133 887)						

Dimensions

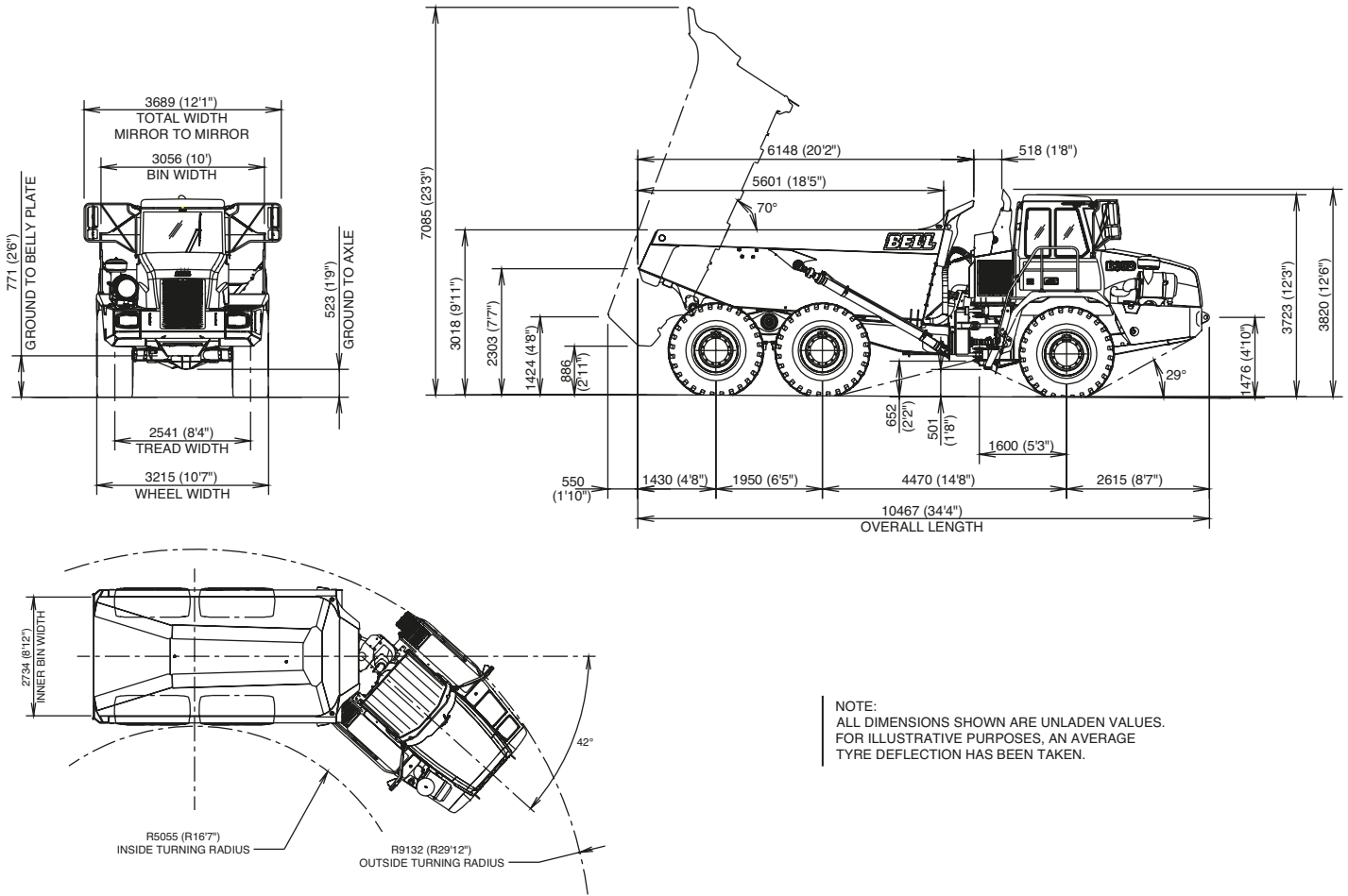

Gradeability / Rimpull

1. Determine tractive resistance by finding intersection of vehicle mass line and grade line. NOTE: 2% typical rolling resistance is already assumed in chart and grade line.
2. From this intersection, move straight left across charts until line intersects rimpull curve.
3. Read down from this point to determine maximum speed attained at that tractive resistance.

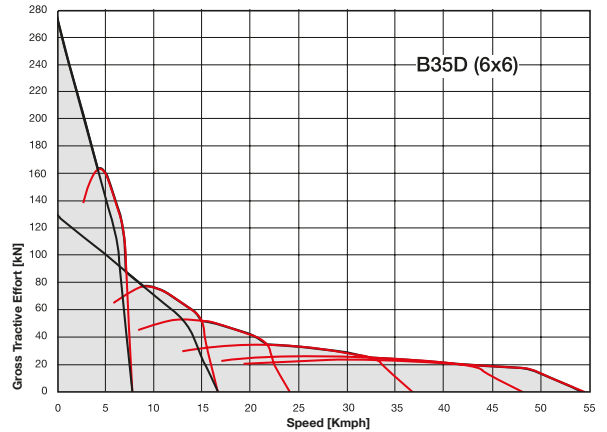
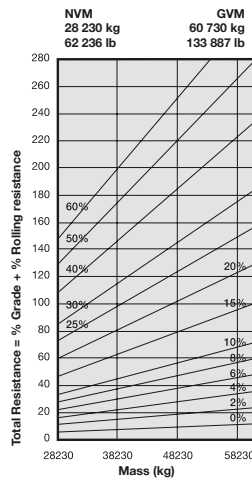

Retardation

1. Determine retardation force required by finding intersection of vehicle mass line.
2. From this intersection, move straight left across charts until line intersects the curve. NOTE: 2% typical rolling resistance is already assumed in chart.
3. Read down from this point to determine maximum speed.

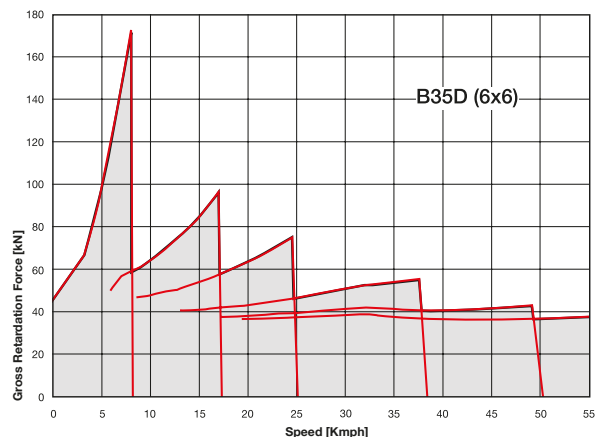
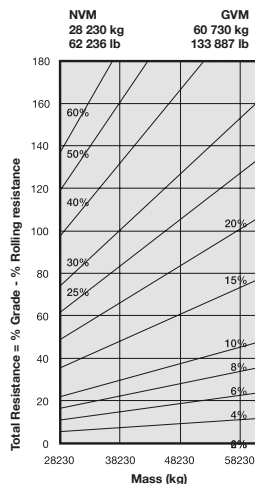

Technical Data - B40D

ENGINE

Mercedes Benz V6, turbocharged, intercooled, low emission diesel engine

Gross Power

335 kW (449 hp) @ 1 800 rpm

Net Power

325 kW (436 hp) @ 1 800 rpm

Torque

2 200 Nm (1 623 lbf) @ 1 080 rpm

Displacement

11,95 litres (729 cu.in)

Fuel Tank Capacity

300 litres (79,26 US gal)

Auxiliary Brake

Automatic exhaust brake
Engine Valve Brake (EVB)

AdBlue® Tank Capacity

40 l (11 US gal)

Certification

OM 501 LA meets EU Stage IIIB/EPA Tier 4i emissions regulations.

TRANSMISSION

Fully automatic Allison planetary transmission.

Layout

Engine mounted

Gear Layout

Constant meshing planetary gears, clutch operated.

Gears

6 Forward, 1 Reverse

Clutch Type

Hydraulically operated multi-disc.

Control Type

Electronic

Torque Control

Hydrodynamic, with lock-up in all gears.

TRANSFER BOX

Remote mounted

Manufacturer

Bell VGR

Model

17 100

Layout

Three in-line helical gears.

Output Differential

Interaxle 33/67 proportional differential, Pneumatically lockable on the move.

AXLES

High strength steel fabricated with spiral bevel type gears on the Controlled Traction differential and heavy duty outboard planetary gears

Model

Bell 25T

BRAKING SYSTEM

Service Brake

Dual circuit, full hydraulic actuation wet disc brakes on front and middle axles.

Maximum Brake Force

263 kN (59 125 lbf)

Park & Emergency

Spring applied, air released driveline mounted disc.

Maximum Brake Force

440 kN (98 920 lbf)

Auxilliary Brake

Automatic exhaust brake
Engine Valve Brake (EVB)
Adjustable Hydraulic retarder.

Maximum Retardation

721 kW (967 hp)

WHEELS

Type

Radial Earthmover

Tyre

29.5R25

FRONT SUSPENSION

Semi-independent, leading A-frame supported by hydro-pneumatic suspension struts.

REAR SUSPENSION

Pivoting walking beams with laminated rubber suspension blocks.

HYDRAULIC SYSTEM

Variable displacement with load sensing system incorporating a ground driven emergency steering pump.

Flow

300 l/min (79,26 US gal/min)

Pressure

25 Mpa (3 626 psi)

Filter

5 microns

STEERING SYSTEM

Hydrostatically actuated by two double acting cylinders, with ground-driven emergency steering pump.

Lock to lock turns

4,7

Steering Angle

42°

DUMPING SYSTEM

Two double-acting, single stage, dump cylinders

Raise Time

13 s

Lowering Time

7,6 s

Tipping Angle

70°

PNEUMATIC SYSTEM

Air drier with heater and integral unloader valve, serving park brake and auxiliary functions.

System Pressure

810 kPa (117 psi)

ELECTRICAL SYSTEM

Voltage

24 V

Battery Type

Two maintenance free permanently sealed.

Battery Capacity

2 X 105 Ah

Alternator Rating

28 V 80 A

VEHICLE SPEEDS

1st	8 km/h	5 mph
2nd	17 km/h	10,6 mph
3rd	24 km/h	15 mph
4th	37 km/h	23 mph
5th	48 km/h	30 mph
6th	54 km/h	33,8 mph
R	6,3 km/h	3,9 mph

CAB

ROPS/FOPS certified

75 dBA internal sound level measured according to ISO 6396.

Load Capacity & Ground Pressure

OPERATING WEIGHTS		GROUND PRESSURE		LOAD CAPACITY		OPTION WEIGHTS	
UNLADEN	kg (lb)	LADEN (No sinkage)	kPa (Psi)	BODY	m³ (yd³)		kg (lb)
Front	14 650 (32 298)	Front	242 (35)	Struck Capacity	18,5 (24)	Bin liner	1 222 (2 694)
Middle	7 810 (17 218)	Middle	302 (44)	SAE 2:1 Capacity	23 (30)	Tailgate	1 002 (2 209)
Rear	7 390 (16 292)	Rear	302 (44)	SAE 1:1 Capacity	27,5 (36)	Extra wheelset	937 (2 066)
Total	29 850 (65 808)			SAE 2:1 Capacity			
				with Autogate	24 (31,5)		
LADEN		LADEN (With sinkage)					
Front	19 587 (43 181)	Front	171 (25)				
Middle	23 842 (52 563)	Middle	201 (29)	Rated Payload	37 000 kg		
Rear	23 422 (51 637)	Rear	201 (29)		(81 571 lb)		
Total	66 851 (147 381)						

Dimensions

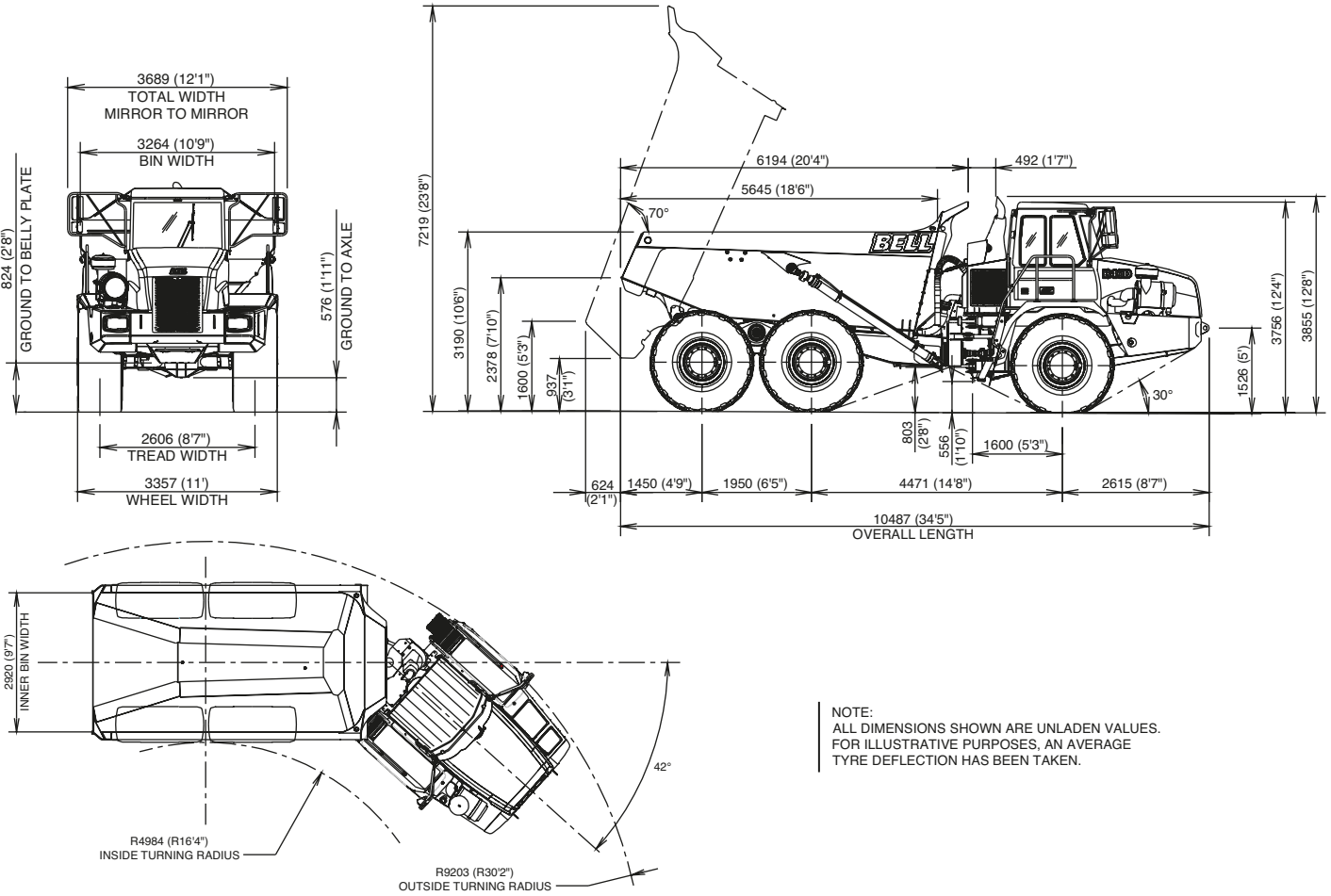

Gradeability / Rimpull

1. Determine tractive resistance by finding intersection of vehicle mass line and grade line. NOTE: 2% typical rolling resistance is already assumed in chart and grade line.
2. From this intersection, move straight left across charts until line intersects rimpull curve.
3. Read down from this point to determine maximum speed attained at that tractive resistance.

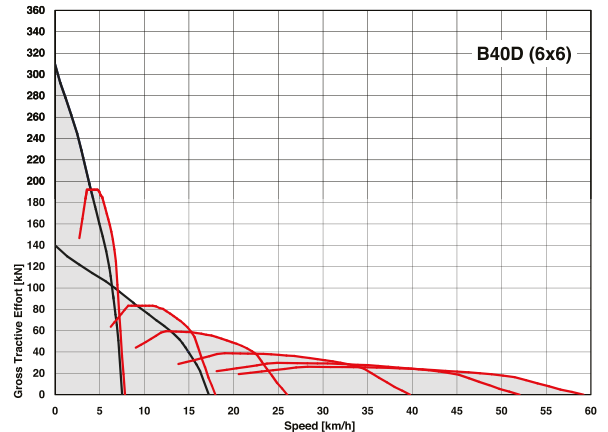
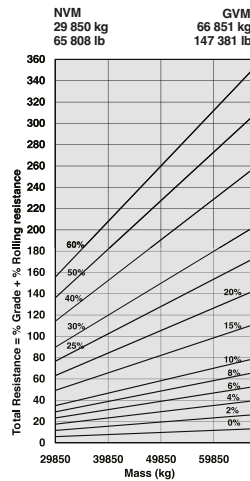

Retardation

1. Determine retardation force required by finding intersection of vehicle mass line.
2. From this intersection, move straight left across charts until line intersects the curve. NOTE: 2% typical rolling resistance is already assumed in chart.
3. Read down from this point to determine maximum speed.

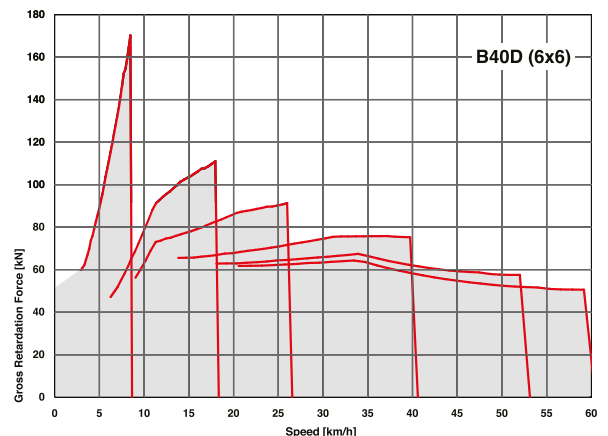
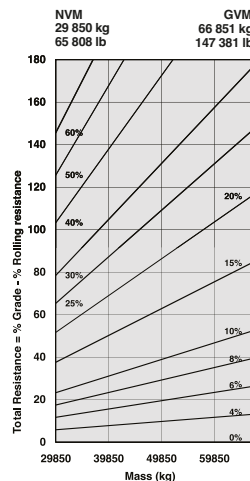

Technical Data - B45D

ENGINE

Mercedes Benz OM502LA, V-8, Turbocharged and intercooled.

Gross Power

375 kW (503 hp) @ 1 800 rpm

Net Power

364 kW (488 hp) @ 1 800 rpm

Torque

2 400 Nm (1 770 lbf) @ 1 300 rpm

Displacement

15,93 litres (972 cu.in)

Fuel Tank Capacity

575 litres (152 US gal)

AdBlue® Tank Capacity

66 l (17 US gal)

Certification

OM 502 LA meets EU Stage IIIB/EPA Tier 4i emissions regulations.

TRANSMISSION

Full automatic planetary transmission with integral retarder.

Layout

Engine mounted

Gear Layout

Constant meshing planetary gears, clutch operated.

Gears

6 Forward, 1 Reverse

Clutch Type

Hydraulically operated multi-disc

Control Type

Electronic

Torque Control

Hydrodynamic, with lock-up in all gears.

TRANSFER BOX

Manufacturer

Bell VGR

Model

17 100

Layout

Three in-line helical gears

Output Differential

Interaxle 33/67 proportional differential, pneumatically spring lockable whilst stationary or on the move.

AXLES

High strength steel fabricated with spiral bevel type gears on the Controlled Traction differential and heavy duty outboard planetary gears.

Final drive type

Outboard heavy duty planetary on all axles.

Housing type

Steel fabricated

BRAKING SYSTEM

Service Brake

Dual circuit, full hydraulic oil immersed wet multidisc brakes on all three axles.

Maximum Brake Force

395 kN (88 583 lbf)

Park & Emergency

Spring applied, air released driveline mounted disc.

Maximum Brake Force

440 kN (98 920 lbf)-Static

105 kN (23 605 lbf)-Dynamic

Auxiliary Brake

Automatic exhaust brake
Engine Valve Brake (EVB).

RETARDATION SYSTEM

Engine Brake

Automatic exhaust brake and Engine Valve Brake (EVB)

Maximum Retardation Power

345 kW (463 hp)

Transmission Retarder

Integral hydrodynamic, output shaft speed dependant, six selectable levels of retardation

Total Retardation Power

797 kW (1 069 hp)

WHEELS

Type

Radial Earthmover

Tyre

29.5R25

FRONT SUSPENSION

Semi-independent, leading A-frame supported by hydro-pneumatic suspension struts.

REAR SUSPENSION

Pivoting walking beams with laminated rubber suspension blocks.

HYDRAULIC SYSTEM

Variable displacement with load sensing system serving the prioritized steering, body tipping, suspension and brake functions. A ground-driven, load sensing emergency steering pump is integrated into the main system.

Pump Type

Variable displacement, loadsensing piston.

Flow

350 l/min (93 US gal/min)

Pressure

25 Mpa (3 626 psi)

Filter

5 microns

STEERING SYSTEM

Hydrostatically actuated by two double acting cylinders, with ground-driven emergency steering pump.

Angle

42°

Lock to lock turns

4,2

DUMPING SYSTEM

Two double-acting, single stage, dump cylinders.

Raise Time

11.2 s (60° tip angle)

Power Down Time

9.9 s (60° tip angle)

Tipping Angle

70° standard, or any lower angle programmable.

PNEUMATIC SYSTEM

Air drier with heater and integral unloader valve, serving park brake and auxiliary functions.

System Pressure

810 kPa (117 psi)

ELECTRICAL SYSTEM

Voltage

24 V

Battery Type

Two maintenance free permanently sealed.

Battery Capacity

2 X 105 Ah

Alternator Rating

28 V 80 A

VEHICLE SPEEDS

1st	7 km/h	4 mph
2nd	14 km/h	9 mph
3rd	21 km/h	13 mph
4th	31 km/h	19 mph
5th	41 km/h	25 mph
6th	47 km/h	29 mph
R	7 km/h	4 mph

CAB

ROPS/FOPS certified

74 dBA internal sound level measured according to ISO 6396.

Load Capacity & Ground Pressure

OPERATING WEIGHTS		GROUND PRESSURE		LOAD CAPACITY		OPTION WEIGHTS	
UNLADEN	kg (lb)	LADEN (No sinkage)	kPa (Psi)	BODY	m³ (yd³)		kg (lb)
Front	17 230 (37 986)	Front	275 (40)	Struck Capacity	20 (26)	Bin liner	1 360 (2 998)
Middle	7 890 (17 395)	Middle	340 (49)	SAE 2:1 Capacity	25,5 (33,5)	Tailgate	1 076 (2 372)
Rear	7 860 (17 328)	Rear	340 (49)	SAE 1:1 Capacity	31 (41)	Extra wheelset	937 (2 066)
Total	32 980 (72 708)			SAE 2:1 Capacity			
		LADEN (With sinkage)		with Autogate	26,5 (35)		
Front	21 190 (46 716)	Front	189 (27)				
Middle	26 410 (58 224)	Middle	230 (33)	Rated Payload	41 000 kg		
Rear	26 380 (58 158)	Rear	230 (33)		(90 390 lb)		
Total	73 980 (163 098)						

Dimensions

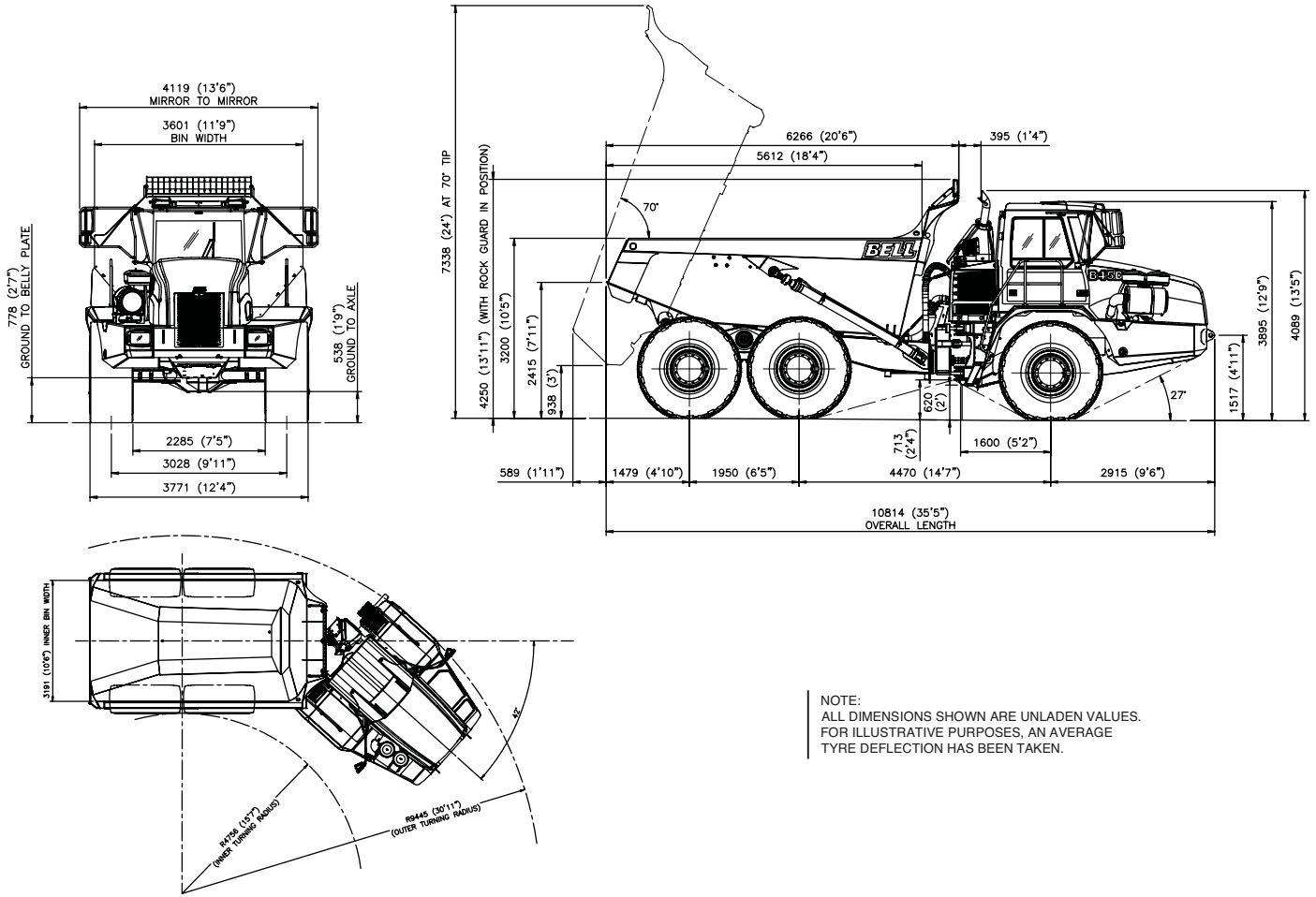

NOTE:
 ALL DIMENSIONS SHOWN ARE UNLADEN VALUES.
 FOR ILLUSTRATIVE PURPOSES, AN AVERAGE
 TYRE DEFLECTION HAS BEEN TAKEN.

Gradeability / Rimpull

1. Determine tractive resistance by finding intersection of vehicle mass line and grade line. NOTE: 2% typical rolling resistance is already assumed in chart and grade line.
2. From this intersection, move straight left across charts until line intersects rimpull curve.
3. Read down from this point to determine maximum speed attained at that tractive resistance.

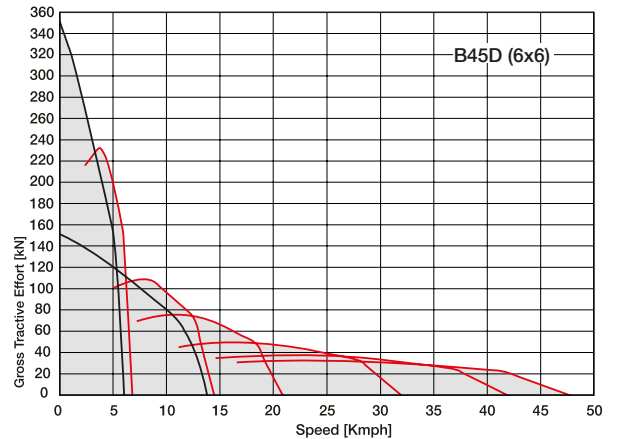
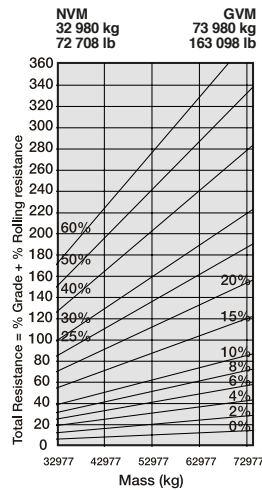

Retardation

1. Determine retardation force required by finding intersection of vehicle mass line.
2. From this intersection, move straight left across charts until line intersects the curve. NOTE: 2% typical rolling resistance is already assumed in chart.
3. Read down from this point to determine maximum speed.

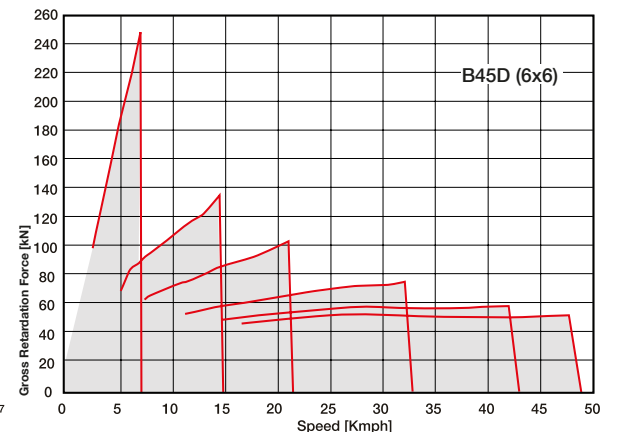
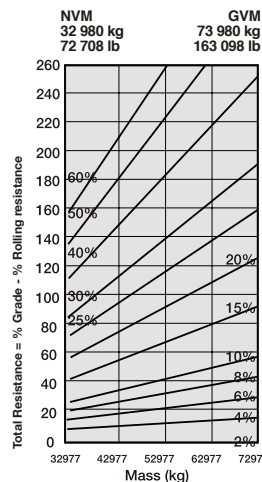

Technical Data - B50D

ENGINE

Mercedes Benz OM502LA, V-8, Turbocharged and intercooled.

Gross Power

375 kW (503 hp) @ 1 800 rpm

Net Power

364 kW (488 hp) @ 1 800 rpm

Torque

2 400 Nm (1 770 lbf) @ 1 200 rpm

Displacement

15,93 litres (972 cu.in)

Fuel Tank Capacity

460 litres (122 US gal)

AdBlue® Tank Capacity

66 l (17 US gal)

Certification

OM 502 LA meets EU Stage IIIB/EPA Tier 4i emissions regulations.

TRANSMISSION

Full automatic planetary transmission with integral retarder.

Layout

Engine mounted with rear output

Gear Layout

Constant meshing planetary gears, clutch operated.

Gears

6 Forward, 1 Reverse

Clutch Type

Hydraulically operated multi-disc

Control Type

Electronic

Torque Control

Hydrodynamic, with lock-up in all gears.

TRANSFER BOX

Manufacturer

Bell VGR

Model

17 100

Layout

Three in-line helical gears

Output Differential

Interaxle 33/67 proportional differential, pneumatically spring lockable whilst stationary or on the move.

AXLES

High strength steel fabricated with spiral bevel type gears on the Controlled Traction differential and heavy duty outboard planetary gears.

Final drive type

Outboard heavy duty planetary on all axles.

Housing type

Steel fabricated

BRAKING SYSTEM

Service Brake

Dual circuit, full hydraulic oil immersed wet multidisc brakes on all three axles.

Maximum Brake Force

391 kN (87 686 lbf)

Park & Emergency

Spring applied, air released driveline mounted disc.

Maximum Brake Force

440 kN (98 920 lbf)-Static

105 kN (23 605 lbf)-Dynamic

Auxiliary Brake

Automatic exhaust brake
Engine Valve Brake (EVB).

RETARDATION SYSTEM

Engine Brake

Automatic exhaust brake and Engine Valve Brake (EVB).

Maximum Retardation Power

345 kW (463 hp)

Transmission Retarder

Integral hydrodynamic, output shaft speed dependant, six selectable levels of retardation.

Total Retardation Power

797 kW (1 069 hp)

WHEELS

Type

Radial Earthmover

Tyre

875/65R29

FRONT SUSPENSION

Semi-independent, leading A-frame supported by hydro-pneumatic suspension struts.

REAR SUSPENSION

Pivoting walking beams with laminated rubber suspension blocks.

HYDRAULIC SYSTEM

Full load sensing system serving the prioritized steering, body tipping, suspension and brake functions. A ground-driven, load sensing emergency steering pump is integrated into the main system.

Pump Type

Variable displacement, load sensing piston.

Flow

350 l/min (93 US gal/min)

Pressure

25 Mpa (3 626 psi)

Filter

5 microns

STEERING SYSTEM

Hydrostatically actuated by two double acting cylinders, with ground-driven emergency steering pump.

Angle

42°

Lock to lock turns

4,2

DUMPING SYSTEM

Two double-acting, single stage, dump cylinders.

Raise Time

11,2 s (60° tip angle)

Power Down Time

9,9 s (60° tip angle)

Tipping Angle

70° standard, or any lower angle programmable.

PNEUMATIC SYSTEM

Air drier with heater and integral unloader valve, serving park brake and auxiliary functions.

System Pressure

810 kPa (117 psi)

ELECTRICAL SYSTEM

Voltage

24 V

Battery Type

Two maintenance free permanently sealed.

Battery Capacity

2 X 105 Ah

Alternator Rating

28 V 80 A

VEHICLE SPEEDS

1st	7 km/h	4 mph
2nd	14 km/h	9 mph
3rd	21 km/h	13 mph
4th	31 km/h	19 mph
5th	41 km/h	25 mph
6th	47 km/h	29 mph
R	7 km/h	4 mph

CAB

ROPS/FOPS certified

74 dBA internal sound level measured according to ISO 6396.

Load Capacity & Ground Pressure

OPERATING WEIGHTS		GROUND PRESSURE		LOAD CAPACITY		OPTION WEIGHTS	
UNLADEN	kg (lb)	LADEN (No sinkage)	kPa (Psi)	BODY	m³ (yd³)		kg (lb)
Front	17 550 (38 691)	Front	274 (40)	Struck Capacity	22 (29)	Bin liner	1 451 (3 212)
Middle	8 500 (18 850)	Middle	335 (49)	SAE 2:1 Capacity	28 (37)	Tailgate	1 139 (2 511)
Rear	8 470 (18 673)	Rear	333 (48)	SAE 1:1 Capacity	34 (44,5)	Extra wheelset	1 031 (2 273)
Total	34 520 (76 104)			SAE 2:1 Capacity with Autogate	29,5 (39)		
LADEN		LADEN (With sinkage)		Rated Payload	45 400 kg		
Front	23 440 (51 676)	Front	172 (25)		(100 090 lb)		
Middle	28 225 (62 225)	Middle	207 (30)				
Rear	28 255 (62 292)	Rear	207 (30)				
Total	79 920 (176 193)						

Dimensions

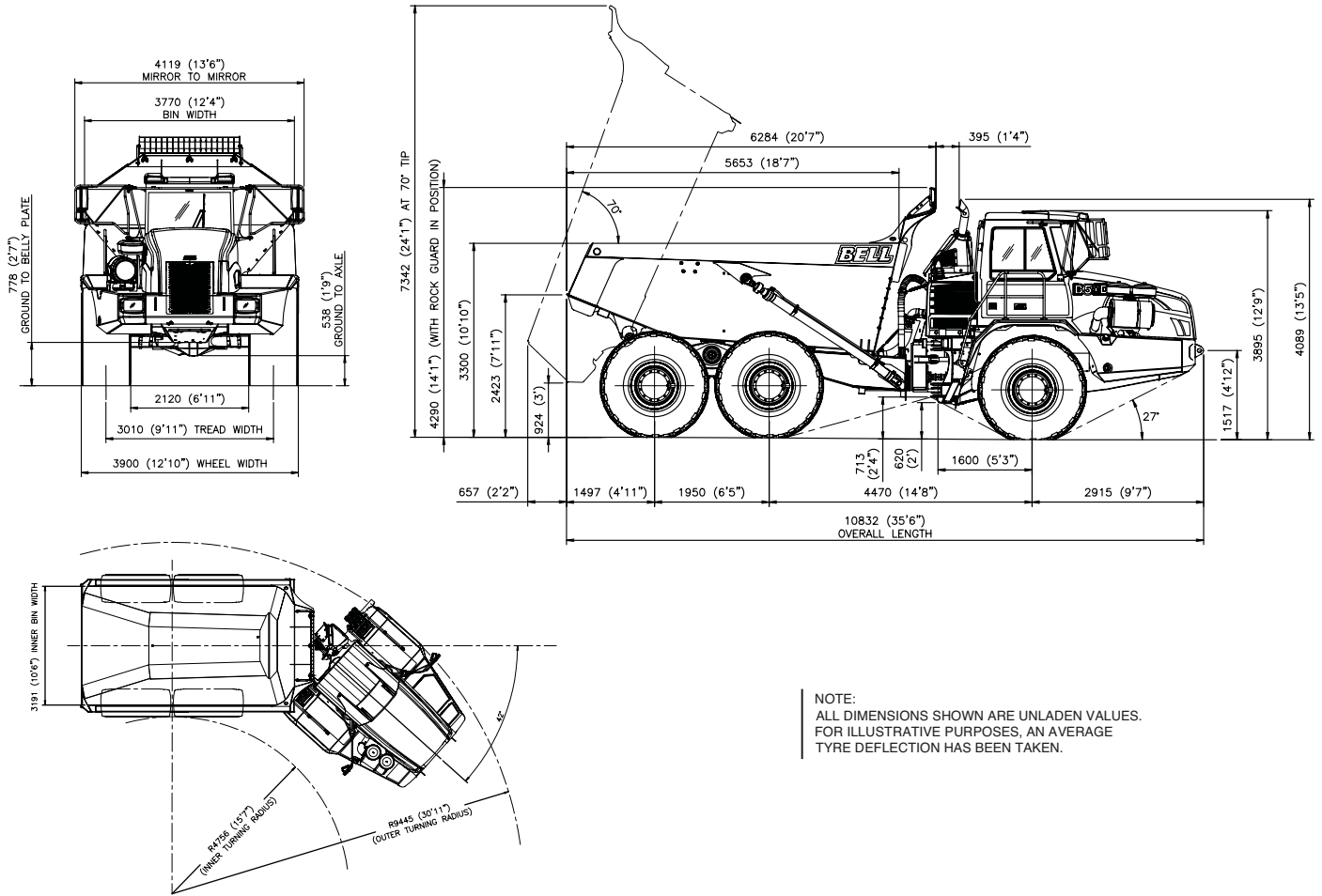

Gradeability / Rimpull

1. Determine tractive resistance by finding intersection of vehicle mass line and grade line. NOTE: 2% typical rolling resistance is already assumed in chart and grade line.
2. From this intersection, move straight left across charts until line intersects rimpull curve.
3. Read down from this point to determine maximum speed attained at that tractive resistance.

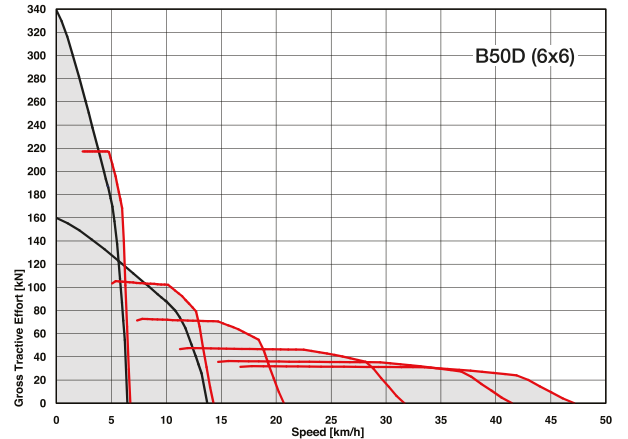
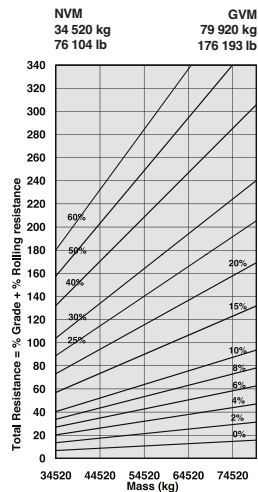

Retardation

1. Determine retardation force required by finding intersection of vehicle mass line.
2. From this intersection, move straight left across charts until line intersects the curve. NOTE: 2% typical rolling resistance is already assumed in chart.
3. Read down from this point to determine maximum speed.

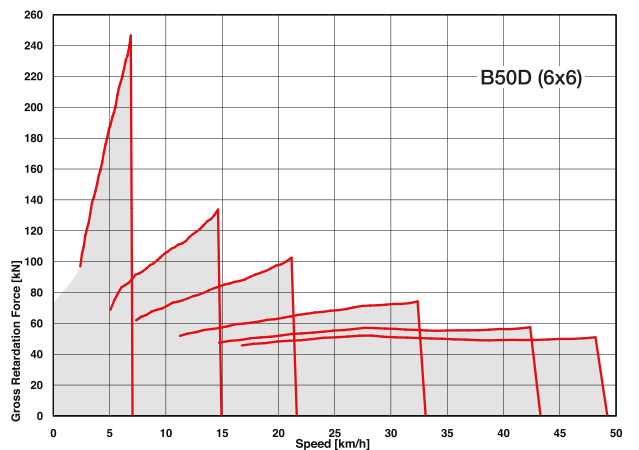
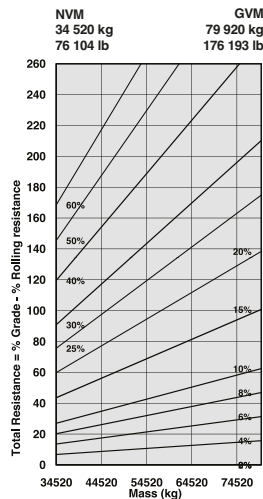

Features and Options

	B35D	B40D	B45D	B50D		● STANDARD	▲ OPTION
ENGINE							
●	●	●	●	●	Wet-sleeve cylinder liners	●	
●	●	●	●	●	Engine valve brake and exhaust brake	●	
●	●	●	●	●	Dual-element air cleaner with dust ejector valve	●	
●	●	●	●	●	Precleaner	●	
●	●	●	●	●	Water separator	●	
●	●	●	●	●	Provision for fast fill	●	
●	●	●	●	●	Serpentine drive belt with automatic tensioner	●	
COOLING							
●	●	●	●	●	Crankshaft-mounted viscous-drive fan	●	
●	●	●	●	●	Remote speed controlled hydraulic fan drive	●	
●	●	●	●	●	Fan guard	●	
PNEUMATIC SYSTEM							
●	●	●	●	●	Engine-mounted compressor	●	
●	●	●	●	●	Air drier with heater	●	
●	●	●	●	●	Integral unloader valve	●	
ELECTRICAL SYSTEM							
●	●	●	●	●	Battery disconnect	●	
●	●	●	●	●	Drive lights	●	
▲	▲	●	●	●	Deluxe work lights	▲	
●	●	●	●	●	Electric hooter	●	
●	●	●	●	●	Air horn	●	
●	●	●	●	●	Reverse alarm	●	
●	●	●	●	●	Rotating beacon	●	
●	●	●	●	●	Pitch Roll sensor	●	
STEERING SYSTEM							
●	●				Ground-driven secondary steering pump	●	
		●	●		Bi-directional ground-driven secondary steering pump		
CAB							
●	●	●	●	●	ROPS/FOPS certification	●	
●	●	●	●	●	Tilt cab	●	
●	●	●	●	●	Gas strut-supported door	●	
●	●	●	●	●	I-Tip programmable dump-body tip settings	●	
●	●	●	●	●	HVAC Climate control system	●	
●	●	●	●	●	AM/FM radio/CD player	●	
●	●	●	●	●	Rear window guard	●	
●	●	●	●	●	Wiper/washer with intermittent control	●	
●	●	●	●	●	Tilt and telescoping steering wheel	●	
●	●	●	●	●	Centre-mount air-suspension seat	●	
●	●	●	●	●	Rear window wiper	●	
▲	▲	▲	▲	▲	3-Point retractable seat belt harness	▲	
●	●	●	●	●	Foldaway trainer seat with retractable seat belt	●	
CAB							
●	●	●	●	●	12-volt power outlet	●	
●	●	●	●	●	Cup holder	●	
●	●	●	●	●	Cooled/heated lunch box	●	
●	●	●	●	●	Ashtray	●	
●	●	●	●	●	Electric adjustable and heated mirrors	●	
●	●	●	●	●	Deluxe monitor:	●	
					Analog speedometer / Fuel gauge /		
					Transmission oil temperature gauge /		
					Engine coolant temperature gauge /		
					LED function/warning indicators and audible		
					alarm / Transmission gear selection /		
					Tachometer / Battery voltage / Hour meter /		
					Odometer / Fuel consumption / Tip counter /		
					Trip timer / Trip distance / Metric/English units /		
					Service codes/diagnostics		
					Backlit sealed switch module functions:		
					Wiper control / Lights / Heated mirrors /		
					Retarding aggressiveness / Controlled traction		
					differentials (B35D/B40D/B50D) / Transfer case		
					differential lock / Transmission gear hold /		
					Dump-body tip limit / Automatic dump-body		
					tip settings / Airconditioner/ Heater controls /		
					Preselected Speed Control		
DUMP BODY							
●	●	●	●	●	Dump-body mechanical lock	●	
▲	▲	▲	▲	▲	Body liner	▲	
▲	▲	▲	▲	▲	Tailgate	▲	
▲	▲	▲	▲	▲	Body heater	▲	
▲	▲	▲	▲	▲	Less dump body and cylinders	▲	
		●	●		Spill guard		
OTHER							
●	●	●	●	●	Automatic Traction Control (ATC)	●	
●					26.5R25 radial earthmover tyres	●	
	●	●	▲		29.5R25 radial earthmover tyres		
		▲	●		875/65R29 radial earthmover tyres		
●	●				Remote grease banks	●	
▲	▲	●	●		Automatic greasing	▲	
●	●	●	●		Onboard weighing	●	
▲	▲	▲	▲	▲	Load lights	▲	
▲	▲	●	●		Comfort ride suspension (front)	▲	
▲	▲	▲	▲	▲	Comfort ride suspension (rear)	▲	
▲	▲	▲	▲	▲	Reverse camera	▲	
▲	▲	▲	▲	▲	Hand rails	▲	
▲	▲	●	●		Cab peak	▲	



All dimensions are shown in millimetres, unless otherwise stated between brackets.
 Under our policy of continuous improvement, we reserve the right to change technical data
 and design without prior notice. Photographs featured in this brochure may include optional
 equipment. Blu@dantage™ is a trademark of Bell Equipment Co. (PTY) Ltd.
 AdBlue® is a registered trademark of VDA.

BELL INTERNATIONAL: Tel: +27 (0)35-907 9431

E-mail: marketing@bellequipment.com

Web: www.bellequipment.com



Tel: +61 (0)8-9356-1033



Tel: +49 (0)6631 / 91-13-0



Tel: +27 (0)11-928-9700



Tel: +44 (0)1283-712862



Tel: +33 (0)5-55-89-23-56



Tel: +7-495-287-80-02



Tel: +34-91-879-60-19



Tel: +1-855-494-2355

**Strong Reliable Machines
 Strong Reliable Support**

BELL