

B40D 6x6

ARTICULATED HAULER



- Gross Power: 335 kW
- Gross Torque: 2 100 Nm
- Gross Combined Mass: 105 000 kg

BELL

B40D^{6x6} ARTICULATED HAULER

STANDARD EQUIPMENT

Body

- Jost 37C fifth wheel hitch
- Standard Bell dia 90 ball hitch fitted on rear plate
- Increased departure angle
- Trailer brake kit, integrated with EVB
- 2 x Fire extinguishers fitted to mudguard

APPLICATIONS

- Rough terrain lowbed trailer hauler
- Jinker trailer
- Scraper tractor

OPERATING WEIGHTS

Laden:	Front	19 587 kg
	Middle	23 842 kg
	Rear	23 422 kg
	Total	66 851 kg

Max load transfer 41 000 kg

LINE DRAWINGS

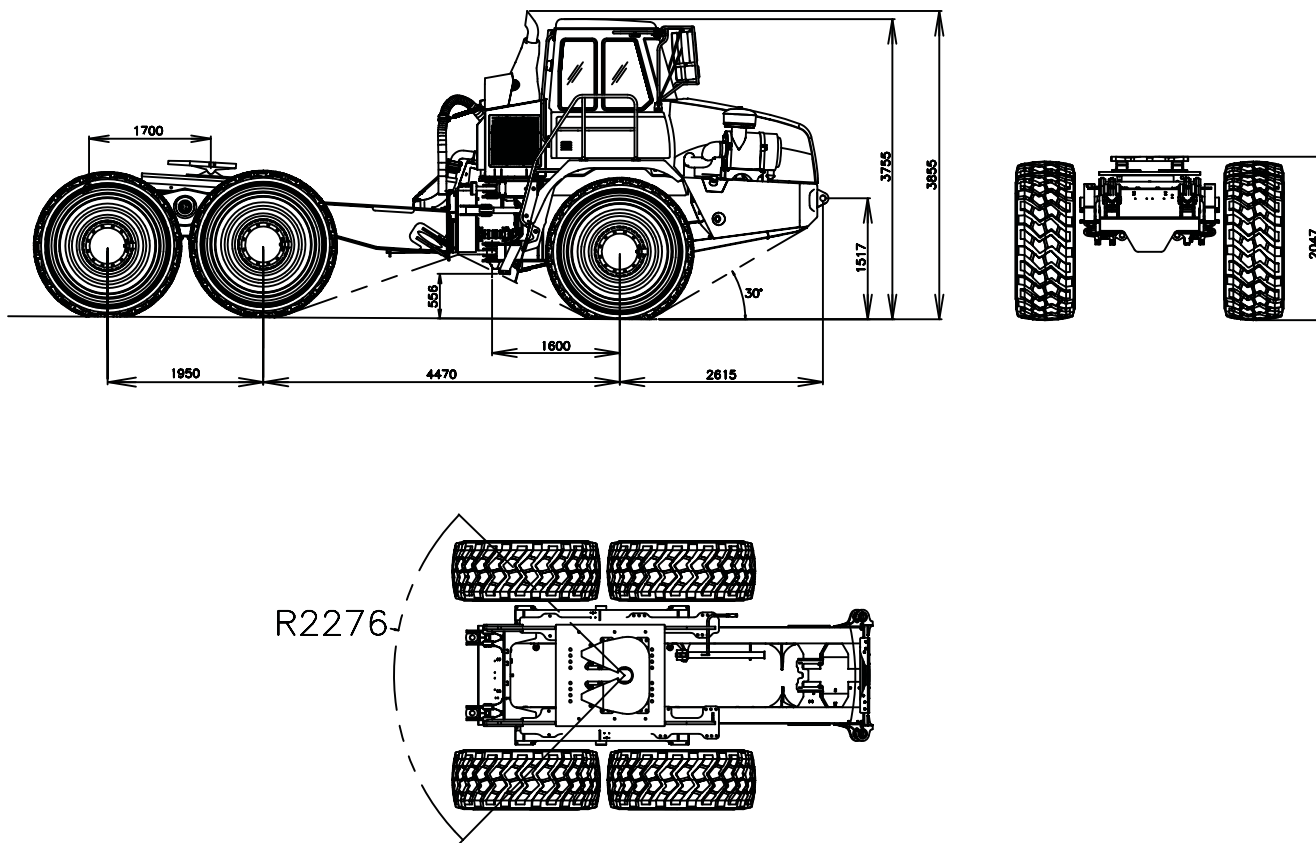

BELL INTERNATIONAL : Tel: +27 (0) 35 907 9431



Tel: +27 11 928 9700



Tel: +49 6631 911 30



Tel: +33 555 89 23 56



Tel: +34 918 796 019



Tel: +7 495 647 20 90



Tel: +44 1283 712 862

E-mail: sales@bellequipment.com • www.bellequipment.com

All dimensions are shown in millimetres, unless otherwise stated between brackets. Under our policy of continuous improvement, we reserve the right to change specifications and design without prior notice. Photographs featured in this brochure may include optional equipment.

**Strong Reliable Machines
Strong Reliable Support**

BELL