

MT52 MINI TRACK LOADER SPECIFICATIONS

DIMENSIONS

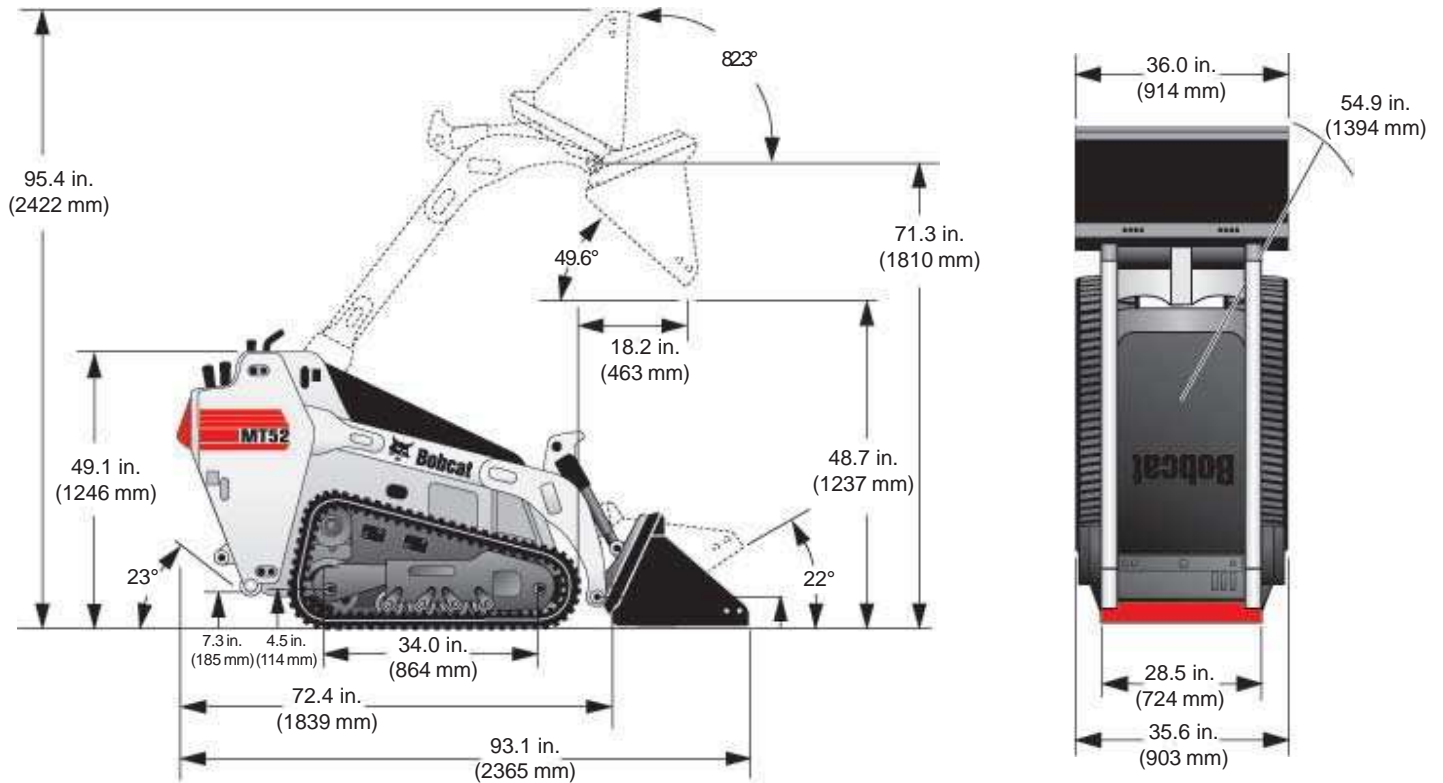

Angle of Departure	23°	Turning Radius with Standard Bucket ..	54.9" (1394 mm)
Carry Position	6.6" (168 mm)	Width	35.6" (904 mm)
Dump Angle @ Maximum Height	49.6°	Wheel Tread (over tracks)	28.5" (724 mm)
Dump Height with Standard Bucket	48.7" (1237 mm)	Width with 36" Bucket	36.0" (914 mm)
Dump Reach @ Maximum Height	18.2" (462 mm)		
Ground Clearance	4.5" (114 mm)		
Ground Clearance-under platform	7.3" (185 mm)		
Height to Bucket Hinge Pin	71.3" (1810 mm)		
Height	49.1" (1246 mm)		
Length without Attachment	72.4" (1839 mm)		
Length with Standard Bucket	93.1" (2364 mm)		
Overall Length with Ride-On Platform ...	97.4" (2474 mm)		
Operating Height	95.4" (2422 mm)		
Rollback @ Carry Position	22°		
Rollback Fully Raised			
@ Maximum Height	82.3°		
Ground Contact Length	34.0" (864 mm)		

PERFORMANCE

Rated Operating Capacity (SAE J732)	520 lbs. (236 kg.)
Tipping Load (SAE)	1600 lbs. (726 kg.)
Operating Weight (SAE)	2580 lbs. (1170 kg.)
Travel Speed (Forward)	3.5 mph (5,6 km/hr)
Travel Speed (Reverse)	1.5 mph (2,3 km/hr)
Lift Breakout Force (SAE)	1660 lbf. (7384 N)
Tilt Breakout Force (SAE)	2795 lbf. (12433 N)

ENGINE/ELECTRICAL

Make/Model	Kubota/D722-E3B-BC-6
Fuel/Cooling	Diesel/Liquid
Horsepower (SAE Gross)	20 HP (14,9 kW)
Maximum Governed RPM	3600 RPM
Torque @ 2600 RPM (SAE Net)	32.4 ft.-lbs. (43,9 Nm)
Number of Cylinders	3
Displacement	44.0 cu. in. (0,72 L)
Bore/Stroke	2.64 in./2.68 in. (67 mm)/(68 mm)
Fuel Consumption	1.1 gal/hr (4,2 L/hr)
Lubrication	Gear Pump Pressure
Crankcase Ventilation	Closed
Air Cleaner	Dry replaceable cartridge with safety element
Ignition	Diesel-Compression
Engine Coolant	Propylene glycol/water mix (53%-47%) with freeze protection to -34°F (-37°C)
Starting Aid	Glow plugs
Alternator	Belt Driven; 40 amps; Open
Battery	12 volt; 530 cold cranking amps @ 0°F (-18°C); 75 minute reserve capacity
Starter	12 volt; Gear Reduction Type; 3.62 HP (2,7 kW)

HYDRAULIC SYSTEM

Pump Type	Engine driven, Gear type
Pump Capacity	12 GPM (45,4 L/min) @ 3750 RPM
System Relief @ Quick Couplers	2900 PSI (200 Bar)
Hydraulic Filter	Full flow replaceable, 10 micron synthetic media element
Hydraulic Cylinders	Double-acting
Control Valve	3-Spool, open center series parallel configuration
Fluid Type	Bobcat Fluid (P/N 6563328) Motor oil is not an acceptable alternative fluid.

Bore Diameter

Lift Cylinder (2)	2.25 in. (57,2 mm)
Tilt Cylinder (1)	3.00 in. (76,2 mm)

Rod Diameter

Lift Cylinder (2)	1.25 in. (31,8 mm)
Tilt Cylinder (1)	1.25 in. (31,8 mm)

Stroke

Lift Cylinder (2)	14.16 in. (359,7 mm)
Tilt Cylinder (1)	10.56 in. (268,2 mm)

Hydraulic Function Times

Raise Lift Arms	3.0 Seconds
Lower Lift Arms	2.0 Seconds
Bucket Dump	1.7 Seconds
Bucket Rollback	1.4 Seconds

DRIVE SYSTEM

- Main Drive Fully hydrostatic rubber track drive
- Transmission Direct drive of hydrostatic motor to main undercarriage drive sprocket
- Tracks 7.0" (180 mm) wide, compression spring with triple flange rollers
- Ground Pressure 5.2 PSI (35,9 kPa)



CAPACITIES

- Cooling System 5 qts. (4,7 L)
- Fuel Tank 7 gals. (26,5 L)
- Engine Oil with Filter 3.4 qts. (3,2 L)
- Hydraulic Reservoir 2.5 gals. (9,5 L)
- Hydraulic System 5.3 gals. (20 L)

CONTROLS

- Vehicle Steering Direction and speed controlled by one multi-function handle
- Loader Hydraulics
 - Lift & Tilt Controlled by one hand lever
 - Front Auxiliary (Std.) Controlled by fore and aft movement of hand lever
- Auxiliary Pressure Release .. Fore and aft movement of hand lever after engine has been shut off.
- Engine Hand lever throttle: Key-type starter switch and shutdown
- Starting Aid Glow Plugs – Activated by key switch
- Service Brake Two independent hydrostatic circuits controlled by one multi-function handle
- Parking Brake Hand lever on right side of control panel

INSTRUMENTATION

The mini track loader conditions are monitored by a combination of gauges and warning lights in the operator's line of sight that monitor the following functions. The system shall alert the operator of monitored loader malfunctions by way of an audible alarm and visual warning lights.

Gauges

Engine Coolant Temperature
Fuel
Hourmeter
System Voltage

Warning Lights

Engine Oil Pressure
Hydraulic Oil Temperature

OPTIONS/ACCESSORIES

Attachment Control Kit
Catalytic Exhaust Purifier
Engine Block Heater
Light Kit
Ride On Platform
Shutdown Kit

STANDARD FEATURES

Auxiliary Hydraulics
Bob-Tach
Built-in Tie Down and Crane/Lift locations
Continuous Flow Shutoff Lever
Hydrostatic Drive Train
Instrumentation: Hourmeter, Engine Coolant Temperature and Fuel Gauge, Voltmeter and Warning Lights
Lift & Tilt Lockout
Lift Arm Lockout with Manual Bypass
Lift Arm Support
Liquid-Cooled Diesel Engine
Neutral Start Interlocks
Parking Brake
Reverse Travel Stop Panel
Spark Arrestor Muffler
Tilt Steering
Tracks: 7" wide (180 mm)

ATTACHMENTS

Adapter Plate
Angle Broom
Auger
Backhoe
Boring Unit
Buckets
Combination Bucket
Digger
Grapple, Farm/Utility
Grapple, Industrial
Hydraulic Breaker
Landplane
Pallet Fork
Snowblower
Soil Conditioner
Stump Grinder
Tiller
Tree Fork
Trencher
Utility Blade
Utility Forks
Vibratory Plow

See **Bobcat Product Price List** for specific attachment model availability

SERVICEABILITY

Access is available to the following:

Through the rear door:

Battery

Under the hood:

Air cleaner

Alternator

Cooling system (radiator and hydraulic oil coolers)

Engine oil and hydraulic filters

Engine oil dipstick

Fuel filter

Fuse/Relay center

Starter

Easy access to all lift arm grease points

Rod end of the tilt cylinder has a replaceable bushing

SAFETY

- Continuous Flow Shutoff Lever (Std.) Allows the auxiliary hydraulic control lever to return to neutral when the drive control is released.
- Lift and Tilt Lockout (Std.) Prevents lowering the lift arm or attachment when engine is off.
- Lift Arm Bypass Control (Std.) Used to lower the lift arms in the event that the lift arms cannot be lowered during normal operating conditions.
- Lift Arm Support (Std.) Use when servicing if lift arms are raised.
- Lift Points (Std.) Lift points are included so loader may be lifted into remote areas.
- Neutral Start Interlocks (Std.) Prevents starting of engine when drive levers or hydraulic auxiliary lever is engaged.
- Operation & Maintenance Manual (Std.) Stored inside the rear door in a weather resistant container. Provides operation and maintenance instructions.
- Parking Brake (Std.) Always set brake when loader is not in use.
- Reverse Travel Stop Panel (Std.) Returns drive levers to neutral when activated.

TRAINING RESOURCES

This videotape is available through Bobcat Parts

Bobcat Mini Track Loader Safety Video

Short and to-the-point video provides basic safety instructions for the Mini Loader.