



Cost-effective transport of personnel and material



Superlift MX 624/1024 – 1524/2024



Substantial economic benefit

Superlift MX

Choose the construction hoist system that will provide you with custom-made solutions for passenger and material transport on all job-sites:

- 650–2,000 kg; 4–12 persons
- Lifting speed 24 or 40 m/min
- Lifting height max. 200 m
- Single or dual mast hoists
- Platform length from 1.70 to 5.10 m
- Platform width from 0.85 to 4.50 m
- Transport platform, material hoist in accordance with EN 12158-1
- In compliance with machinery directive 2006/42/EG
- Type approval by German TÜV



MX 1024-A17 with optional roof



MX 1524-A34 installed in a lift shaft



MX 1524-A17 with a single platform module



MX 2024-B30 with two platform modules parallel to the façade



MX 2024-A51 with three platform modules

Böcker modular construction system

Böcker rack and pinion hoists impress by a completely new and highly versatile modular construction system which is characterised by compatible system components. Masts, platforms as well as gates, ramps and closing walls of the models Superlift MX, Superlift LX and GIANT Lift can be combined variably. So Böcker hoists can be adapted individually to the specific requirements of each project. Beside a tailor-made configuration, significant cost advantages can also be achieved.

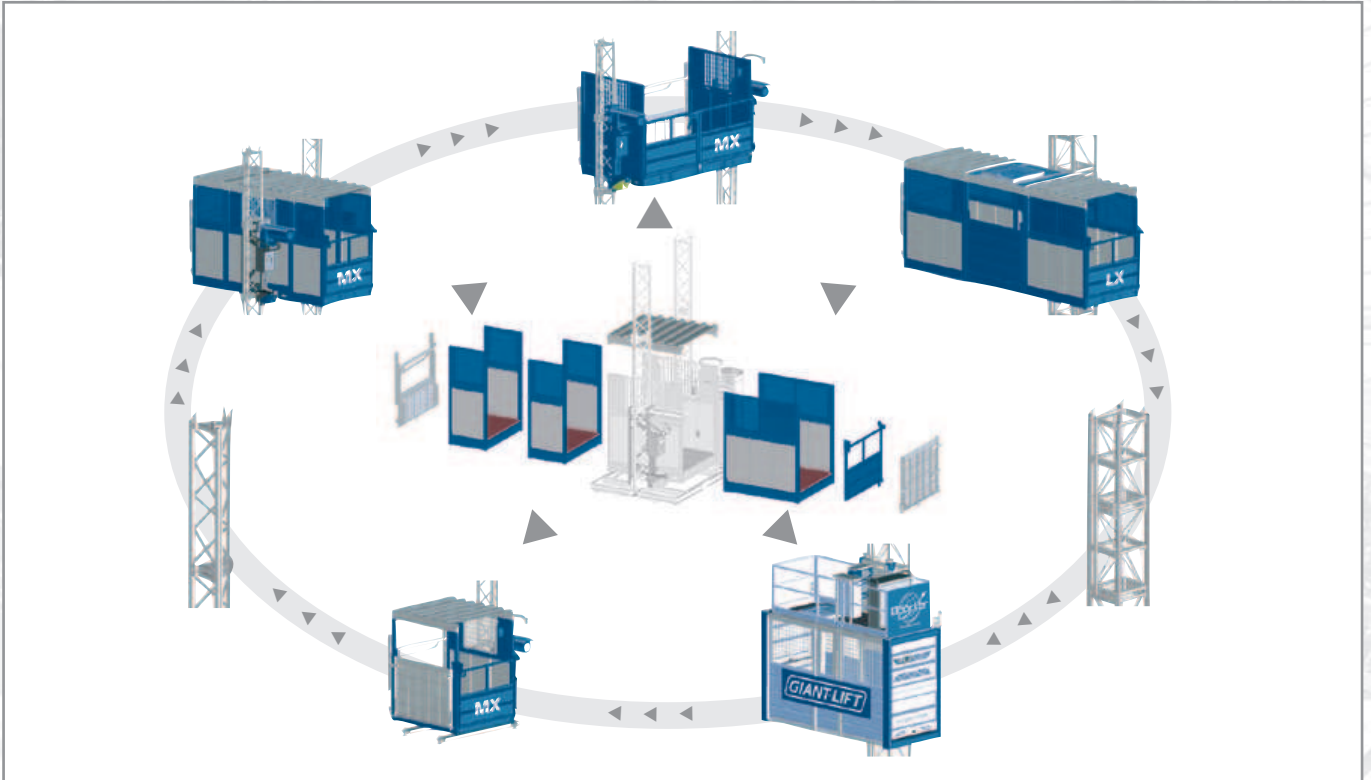

Böcker modular construction system – variable combination of different components

Technical Specifications

Configurations	single mast hoist		dual mast hoist							
	MX 624	MX 1024	MX 1524				MX 2024			
Capacity/Transport platform [Pers./kg]	4/650	6/1000	6/1500	9/1500	12/1500	12/1200	6/2000	9/2000	12/2000	12/1700
Platform size										
A17 1.7 x 0.85 m	X	X								
A17 1.7 x 1.4 m	X	X	X				X			
A25 2.5 x 1.4 m				X				X		
A34 3.4 x 0.85 m	X ¹⁾									
A34 3.4 x 1.4 m					X				X	
A51 5.1 x 1.4 m						X				X
B30 1.7 x 3.0 m					X				X	
B45 1.7 x 4.5 m						X				X
Tie distance [m]	6	6	10	10	10	10	10	10	10	10
Motor capacity [kW]	5,5	7,5	11	11	11	11	15	15	15	15
Fuse [Ampere]	16	16	35	35	35	35	35	35	35	35

1) Capacity 600 kg / 4 persons

All rights reserved for changes in dimension and construction.



Tailor-made for your demands

Variable Platform Configuration

All hoists are based on an identical base unit which can be extended upon request by additional platform modules. No matter if you install the hoist parallelly or perpendicularly to the façade, the variable platform concept ensures a tailor-made configuration of the transport platform in any situation

- Subsequent transformation from perpendicular platform (Type A) to parallel platform (Type B) is possible without a problem (MX 1524/MX 2024)
- An individual completion of the base unit with exit ramps, rotatable and foldable gates or closing walls is easily possible
- Dimensions of the base unit are optimized for transport by truck
- All platforms are available with optional roof and lighting



Possible base unit extensions of the single mast hoists (MX 624/MX 1024)

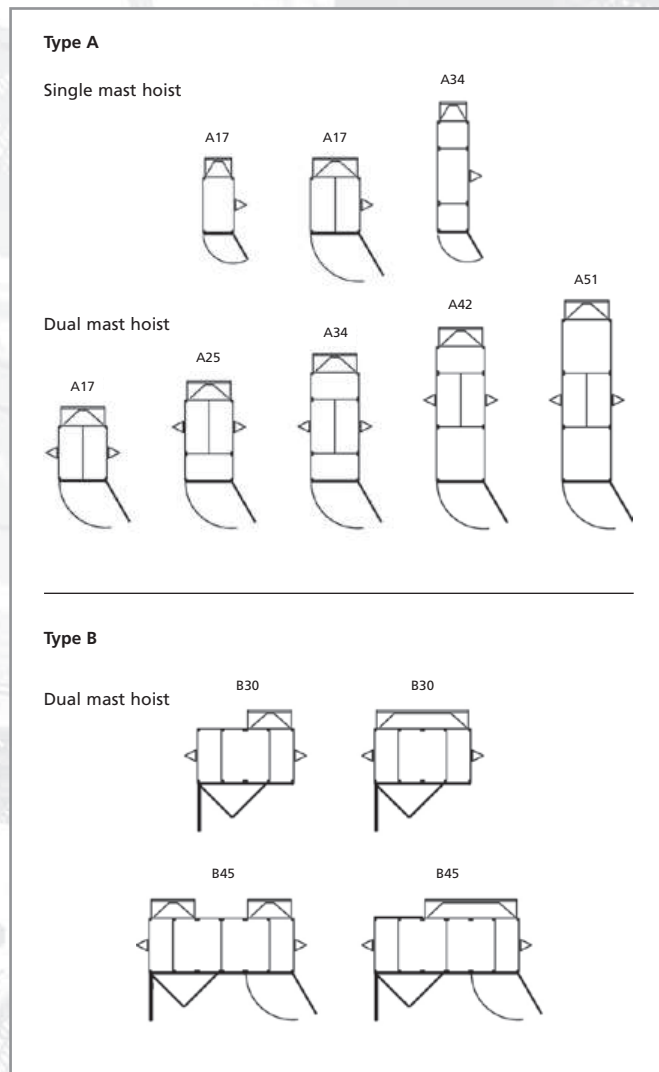

Exemplary platform configurations of the Superlift MX

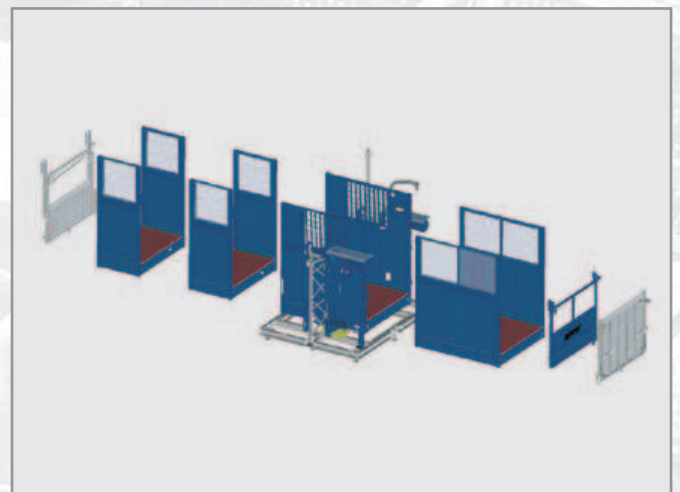

Possible base unit extensions of the dual mast hoist (MX 1524/MX 2024) for perpendicular assembly (Type A)

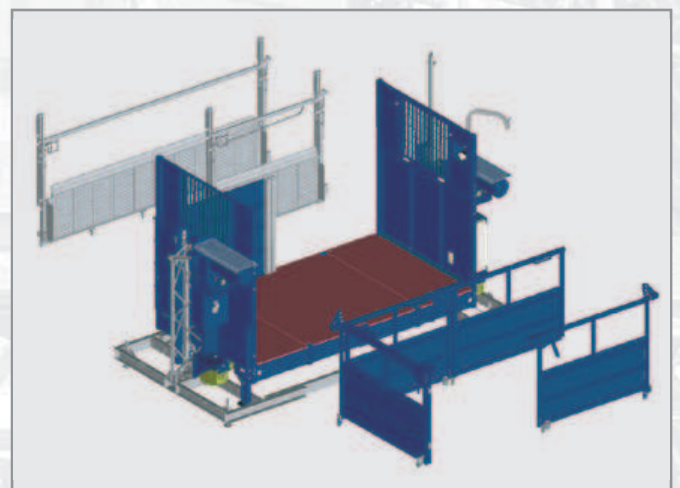

Possible base unit extensions of the dual mast hoist (MX 1524/MX 2024) for parallel assembly (Type B)

Elaborate down to the last detail

Advantages of the MX

User-friendliness

- Convenient passenger and material transport: Hoist can be called from landings at any time
- All operational modes (automatic, inside, outside, off) can be controlled by key upon request
- Constant speed for passenger and material transport

Control

- Modern rotary switch enables precise control and surpassing convenience during long rides

Drive Units

- The Superlift MX reaches lifting speeds of up to 24 m/min – all models are equally available with VFC-drive unit and lifting speeds up to 40 m/min

In Operation

- Cost-effective permanent lubrication ensures a particularly low wear and tear of rack and pinion for all models
- All dual mast lifts (MX 1524/MX 2024) are equipped with tandem rollers to ensure an even higher running smoothness

Rotatable gates and ramps

- Modern locking equally combines user-friendliness and surpassing operational safety
- Exit ramp has been designed to permanently withstand heavy-duty forces



Control via convenient rotary switch



Powerful drive units ensure high lifting speeds up to 40 m/min



Surpassing running smoothness due to tandem rollers (MX 1524/MX 2024)



Cost-effective permanent lubrication

Definitely the right choice

Innovative Technology

PLC Control

- All limit switches of the Superlift MX are continuously monitored by a sophisticated PLC control. Errors – for instance an open gate – are immediately identified and shown as text and error code on the display (optional)
- Failures can be resolved quickly and easily
- Misuse can be identified immediately

Landings

- Landing gates are first choice for all possible operations
- The hoist can be conveniently loaded and unloaded at each landing due to the precise landing approach



Errors are automatically shown on the display (optional)



All landing gates comply with machinery directive 2006/42/EG



Landing with opened platform ramp



Sturdy exit ramp



Safe locking of gates by a simple mechanism

Böcker Belgium NV

Boomsesteenweg 101 · B-2630 Aartselaar
Fon +32 (0) 3/45 76 241
Fax +32 (0) 3/45 76 242
Mail belgium@boecker-group.com

Böcker France SAS

Zac du TEC · F-30320 Marguerittes
Fon +33 (0)4 6620 9364
Fax +33 (0)4 6620 9926
Mail france@boecker-group.com

Böcker Italia srl

Via C. Beccaria 3 · I-37036 San Martino
Fon +39 045 / 87 80 399
Fax +39 045 / 87 80 420
Mail italia@boecker-group.com

Böcker Nederland B.V.

Rolweg 25 · NL-4104 AV Culemborg
Fon +31 (0) 345/51 00 99
Fax +31 (0) 345/51 08 66
Mail nederland@boecker-group.com

Böcker Schweiz AG

Striegelstraße 1 · CH-4665 Oftringen
Fon +41 (0) 62/797 62 62
Fax +41 (0) 62/797 62 68
Mail schweiz@boecker-group.com



Böcker Maschinenwerke GmbH

Lippestraße 69–73 · D-59368 Werne
Fon +49 (0) 23 89/79 83-0
Fax +49 (0) 23 89/79 83-9000
Mail info@boecker-group.com
Web www.boecker-group.com