

TECHNICAL DATA

COLD PLANER

BM 2000/60-2, BM 2200/60-2

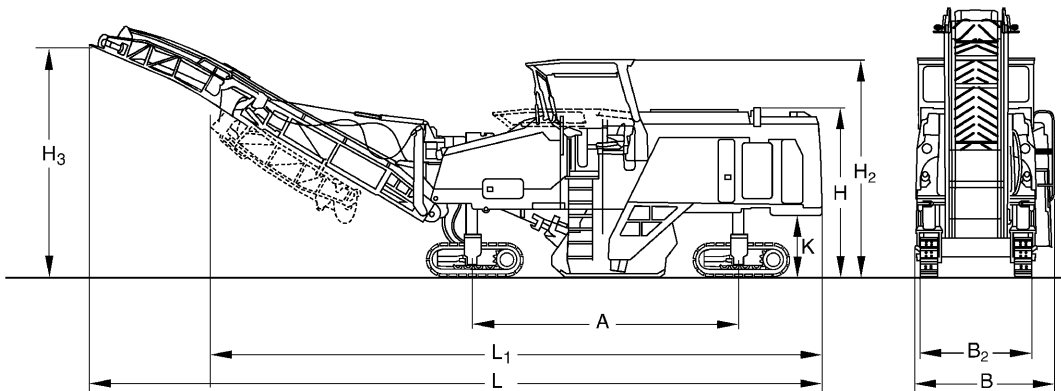



Dimensions in mm

	A	B	B ₂	H	H ₂	H ₃	K	L	L ₁
BM 2000/60-2	4720	2500	1870	2960	3990	4500	1120	14900	12000
BM 2200/60-2	4720	2800	1870	2960	3990	4500	1120	14900	12000

BM 2000/60-2

Milling depth (cm) calculated for asphalt of average hardness	4	8	12	16	24	32
Rate of advance V (m/min)	16,5 - 28	11 - 16	7,5 - 11	5 - 7,5	2,5 - 4	1,5 - 3,5
Area output Ft (m ² /h) (Theoretical)	1980 - 3360	1320 - 1920	900 - 1320	600 - 900	300 - 480	180 - 420
Milling volume Qt (m ³ /h) (Theoretical)	80 - 135	105 - 154	108 - 158	96 - 144	72 - 115	58 - 135

The following factors greatly influence performance when the equipment is employed practically: Different milling material, waiting for lorries, traffic hold-ups, road installations such as manhole covers, hydrants, etc.

Technical Data

Milling Drum

Milling width	mm
Milling depth	mm
Milling line distance	mm
Cutting circle diameter	mm
Number of cutting teeth	
Output per cutting tooth	kW
Milling Drum Speed	min ⁻¹

BOMAG

BM 2000/60-2

BOMAG

BM 2200/60-2

2.000	2.200
0 – 320	0 – 320
15	15
1.070	1.070
168	168
2,62	2,62
108	108

Drive

Engine Manufacturer	
Type	
Cooling	
No. of cylinders / Displacement	cm ³
Power	kW / PS
Engine Speed	U/min
Fuel	
Electric Equipment	V

Deutz	Deutz
TCD 2015	TCD 2015
Liquid cooled	Liquid cooled
8 / 6.000	8 / 6.000
440 / 600	440 / 600
1.900	1.900
Diesel	Diesel
24	24

Weights

Max. Operating weight	kg
Operating weight CE	kg
Basic weight	kg

32.500	33.500
30.300	31.300
28.100	29.100

Driving Characteristics

Track radius, inner	mm
Speed	km/h
Working speed, max.	m/min

2.100	2.100
5,0	5,0
0 – 40	0 – 40

Chassis

Type of chassis	
Width	mm
Height	mm
Length	mm

Chain	Chain
300	300
640	640
1.700	1.700

Capacities

Fuel	l
Water	l
Hydraulic	l

1.200	1.200
3.500	3.500
230	230

Loading-system

Width of gathering belt	mm
Length of gathering belt	mm
Width of loader conveyor belt	mm
Length of loader conveyor belt	mm

800	800
2.400	2.400
800	800
7.600	7.600

Dimensions

Transport dimensions, belt lowered, length	mm
Transport dimensions, belt lowered, width	mm
Transport dimensions, belt lowered, height	mm
Transport dimensions, belt folded, length	mm

14.900	14.900
2.500	2.800
2.960	2.960
12.000	12.000

Technical modifications reserved. Machines may be shown with options.

Standard

- Four-track steering front or/and rear, crabwalk
- Automatic max. load control
- Differential lock
- Automatic milling depth control
- INTELPLANER
- 2 INTELPLANER Displays
- Slope control with slope sensor
- Hydraulically foldable conveyor belt
- Display of RPM
- Display of engine oil pressure and temperature
- Display of operating hours
- Display of diesel level
- Display of hydraulic oil temperature
- Display of hyd. system pressures
- Ground control panels
- Sound insulated engine hood
- 10 removable headlights
- Adjustable water spraying system
- Tool box for servicing and maintenance
- Back-up warning signal
- Rotary beacon

Optional

- Hydraulically foldable canopy
- Canopy with windscreens
- Hydraulically pump for water re-filling
- High pressure cleaner
- Levelling with electromechanical sensor
- Levelling with ultrasound sensor
- Electrical diesel pump for fuelrefilling
- Compressed air system



PRE 836 26 010

110316 Sa

BOMAG
Hellerwald
D-56154 Boppard
Postfach 5162
D-56149 Boppard
Tel. (0)6742 - 1000
Fax (0)6742 - 3090

