



### **Now Standard Equipment:**

#### **Rated Capacity Limiter**

Warns operator of impending overload with audible and visual signals. (1/20/03)

- \* Capacity on outriggers ...8,000 lbs.
- \* Pick and carry capacity ...6,700 lbs.
- \* Boom rotation...continuous
- \* Height...6' 6"
- \* Width...5'
- \* Sheave height up to 33' 6"
- \* Horizontal reach up to...27' 2"
- \* Gas, dual fuel and diesel engine options
- \* Anti-Two Block standard

**DMC<sup>®</sup> BRODERSON<sup>®</sup>**  
Manufacturing Corp.

P.O. Box 14770, Lenexa, KS 66285-4770  
14741 West 106th St. • Lenexa, KS 66215-2015  
(913) 888-0606 • FAX (913) 888-8431  
Website: [bmccranes.com](http://bmccranes.com)

# IC-35-C

CAPACITIES APPLY TO OPERATION ON FIRM LEVEL SURFACE									
LOAD RADIUS FEET	MAIN BOOM OR EXTENSION CAPACITIES IN POUNDS								
	360° ROTATION		OVER FRONT						
	ON RUBBER	ON OUTRIGGERS	ON RUBBER	ON OUTRIGGERS					
4	5000	8000	6700	8000					
5	4000	6800	5800	6800					
6	2850	5850	5100	5850					
8	1800	4150	3500	4150					
10	1250	3200	2350	3400					
12	900	2350	1750	2850					
14	700	1850	1350	2450					
16	600	1500	1100	2150					
18	500	1250	950	1950					
19	450	1150	900	1850					
20	400	1100	850	1600					
22	300	900	700	1450					
24	250	800	600	1300					
26	200	700	500	1150					
27	150	650	450	1100					
8' BOOM EXTENSION	8-FOOT BOOM EXTENSION - STRAIGHT OR OFFSET								
	BOOM EXTENSION ANGLE	MAIN BOOM ANGLE							
		0°	10°	20°	30°	40°	50°	60°	70°
	+* 0°	1100	1200	1300	1450	1600	1850	2300	3500
	*15°	—	—	1100	1250	1350	1500	1700	2050
*30°	—	—	—	1100	1200	1300	1450	1600	

+ USE 0° FOR STRAIGHT BOOM EXTENSION.

\* USE 0°, 15° OR 30° FOR OFFSET BOOM EXTENSION.

BOOM EXTENSION LOADS MUST NOT EXCEED MAIN BOOM CAPACITY.

CAPACITIES ON OUTRIGGERS ARE 85% OF TIPPING LOADS. CAPACITIES ON RUBBER ARE 75% OF TIPPING LOADS. CAPACITIES BELOW BOLD LINE ARE LIMITED BY TIPPING. OTHER CAPACITIES ARE LIMITED BY STRUCTURAL OR HYDRAULIC CAPABILITIES.

CAUTION: BOOM EXTENSION LOADS MUST NOT EXCEED MAIN BOOM CAPACITY. BOOM EXTENSION DEDUCT: 100 LBS. WHEN STOWED ON BASE BOOM, 300 LBS. IN WORK POSITION WITH LOAD ON MAIN BOOM.

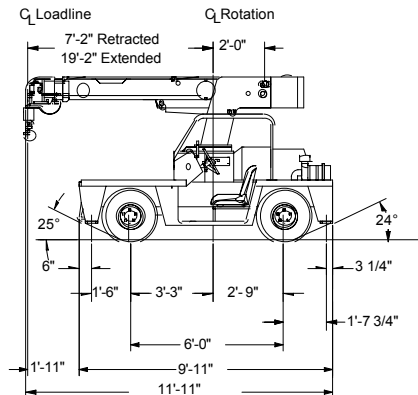
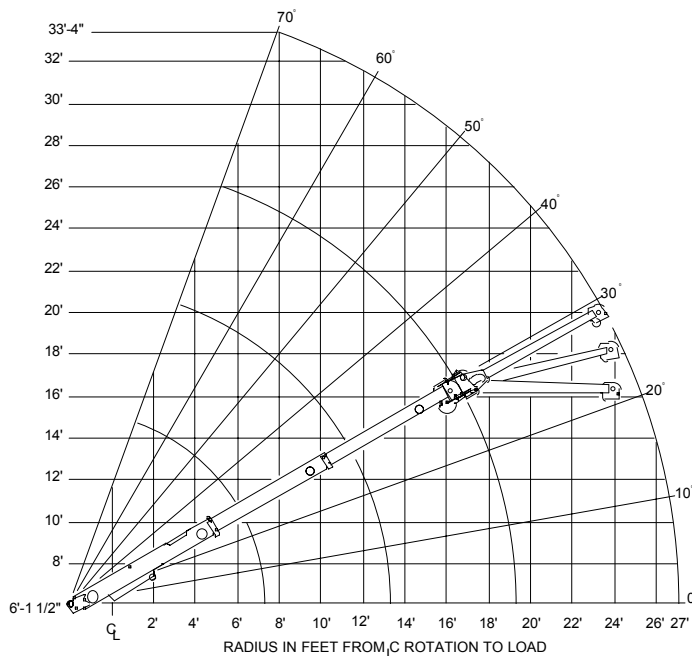
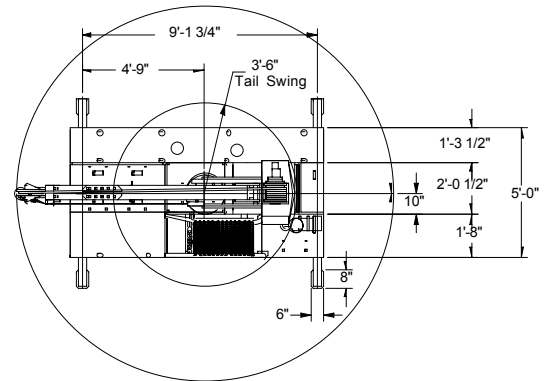
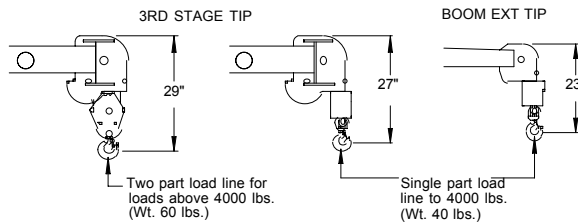
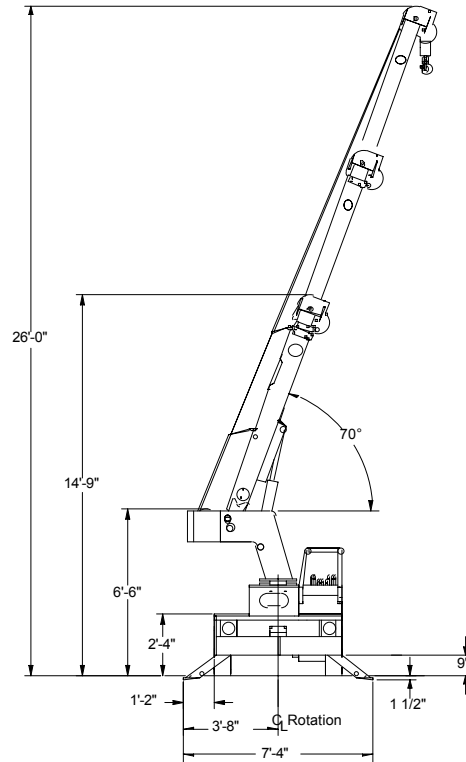

## General:

<b>Weight</b>	7,260 lbs.
<b>Travel Speed</b>	0 to 10 mph
<b>Drawbar Pull</b>	2,300 lbs.
<b>Gradeability</b>	31% (17 degrees)
<b>Boom Movements:</b>	
Rotation	Continuous Rotation
Elevation	0 to 70 degrees
Extension	7 ft. 2 in. to 19 ft. 2 in.
<b>Boom Speeds:</b>	
Rotation	1.5 RPM
Elevation	19 seconds
Extension	36 seconds

<b>Engine:</b>	<b>Standard</b>	<b>Optional</b>
Make	Ford	Perkins
Model	VSG413	104.19-IDI
Type	Gas	Diesel
Cylinders	4	4
Displacement	79 CID	122 CID
HP @ Governed speed	42 HP	42 HP
Fuel Tank Capacity	13.5 Gallons	

## Hydrostatic Pump:

Piston type, direct driven from engine crankshaft. Maximum flow 36 GPM, maximum pressure 4,000 PSI.

## Axles:

### Front Drive Axle:

Channel shaped structure houses torque hubs, brakes & hydraulic drive motors. Axle oscillates a total of 1-1/2".

### Rear Steering Axle:

Fixed rigid to frame.

## Steering:

Full hydraulic unit controls 2-1/2" steering cylinder attached to rear axle.

## Brakes:

Primary braking from hydrostatic transmission. Foot-actuated disc brake attached into each torque hub for additional braking in some conditions. Parking brake switch, locks brakes to hold crane when not being driven.

## Tires:

Front - 7.5 x 10 pneumatic, 16-ply rating.  
Rear - 7.5 x 10 pneumatic, 16-ply rating.

## Chassis:

### Cargo Deck:

29 square feet deck area, 6,000 pounds capacity when centered over front axle or to the rear of front axle.

## Chassis: (Cont'd)

### Outriggers:

Four hydraulic outriggers of box-beam construction. Independent controls for each. Hydraulic cylinders are equipped with direct-connected holding valves.

### Lifting Rings:

Consists of four rings, one at each corner of the load deck.

### Pulling Eye:

Mounted on front bumper.

## Operator's Compartment

Provides one-position access to all chassis and crane functions. Includes adjustable operator's seat, retracting seat belt, fire extinguisher and bubble level.

## Electrical System:

### 12 Volt System

**Lighting Group:** One pair headlights and taillights.

### Instrument Group:

Fuel, ammeter, oil pressure, water temperature, hydrostatic oil temperature gauges & hourmeter. Gauges are lighted.

### Back-Up Alarm:

Provides pulsating 97 decibel sound when transmission is in reverse.

## Hydraulic System:

Tandem pump mounted to rear of hydrostatic piston pump. Delivers 6 GPM at 2,600 PSI for boom circuits & 18 GPM at 2,250 PSI for hoist circuit. System protected by relief valves. Hydraulic oil tank has 14 gallons capacity. Hydraulic oil cooler provided.

## Boom:

### Boom Assembly:

Three-section boom assembly equipped with bearing pads, double-acting hydraulic cylinders equipped with direct-connected holding valve and boom angle indicators on each side of boom.

### Boom Rotation:

Heavy-duty ball bearing rotation gear with external teeth. Rotation is powered by hydraulic motor & worm gear drive.

### Boom Hoist:

Turret-mounted, planetary gear hoist, hydraulically powered with bare drum line pull of 4,600 lbs. and a line speed of 86 FPM. Hoist includes 85 ft. of 3/8 in. wire rope, downhaul weight, swivel hook and sheave block for 2-part line.

### Anti Two-Block Device:

Prevents damage to hoist rope and/or crane components. Dumps hydraulic flow for Hoist Raise, Telescope Extend and Boom Lower.

### Sheave Block

Single sheave block for 2-part line requirements.

# IC-35-C

Listed below are brief descriptions of each option available for the IC-35-2C Industrial Crane. Consult the IC-35-2C Engineering Spec for additional information on each option.

## IC-35-2C, 4-Ton Industrial Crane with Gas Engine.

### Engine Options:

#### LP Gas System

Contains all necessary components for LP Gas.

#### Dual Fuel System

Contains all necessary components to burn LPG or gasoline.

#### Perkins Diesel Engine

Perkins Model 104.19-IDI

#### Spark Arrester Muffler

Installed in addition to standard muffler.

#### Engine Shut Down Gauges

Shuts engine off when high water temperature or low engine oil pressure occurs.

### Tire Option:

#### Solid Rubber Tires

For applications where hazardous ground conditions exist.

#### Non-Marking Solid Rubber Tires

#### Foam Filling of Tires

#### Spare Tire & Wheel

7.50 x 10, 16-ply (front & rear wheels are different).

### Chassis Options:

#### Auxiliary Winch

Mounted behind front bumper, hydraulically driven with control in operator's console (3,000 lbs. @ 20 FPM).

#### Pintle Hook - Rear

Holland "T-60-A" pintle hook mounted on rear of frame. 5-ton capacity.

#### Lifting Sling

Sling to attach to Lifting Rings.

#### Headlight & Taillight Grilles

Welded steel protective grilles for headlights and taillights.

### Operator Compartment Options:

#### All Weather Cab

Rigid-mounted canopy section and removable hinged door. Cab door adds 4 inches to crane width. Includes heater, windshield wiper, defroster fan, dome light & sliding window in door. Cannot be used with Operator Guard.

#### Cab Heater

Heater with two-speed fan, for units without All Weather Cab.

#### Operator Guard

Tubular steel weldment with heavy expanded steel mesh top section.

#### Operator Guard Cover

Clear vinyl cover to go over Operator Guard, for inclement weather operations.

#### Floor Mat:

Vinyl mat with foam backing.

### Electrical Options:

#### Outrigger Alarm System

Two-tone alarm is activated when "Outrigger Down" controls are operated.

#### Strobe Lights

Two yellow strobe lights mounted to turntable.

#### Boom Work Lights

One work light mounted to boom to light boom tip and one work light mounted to turret to light ground under boom tip.

#### Boom Work Lights & Strobes

Boom work lights and strobes installed.

### Wire Rope:

140 ft. of 3/8 in. dia. wire rope.

### Boom Attachment Options:

#### Boom Extension

8 foot, boom stowable.

#### Boom Extension, Offset

8 foot, boom stowable, the boom extension is offsettable to 3 different positions. 0 degree (inline), 15 degree and 30 degree offset.

#### Searcher Hook

2,000 pound capacity. Swivel hook with spring latch hangs from support structure projecting outward from boom tip.

#### Load Moment Indicator

Warns operator of impending overload with audible and visual signals. Prevents overload by stopping boom functions that cause overloads. Readouts for load, boom angle, boom length and load radius.

#### Load Indicator

Three sheave load sensor on top of boom & readout box on top of instrument panel.

**Should you, as the end user, require an option or special equipment on your IC-35-2C that is not listed on our sales literature, please contact your dealer sales-person or the factory to receive a special quoted price.**

**BMC BRODERSON**  
Manufacturing Corp.

P.O. Box 14770, Lenexa, KS 66285-4770  
14741 West 106th St. • Lenexa, KS 66215-2015  
(913) 888-0606 • FAX (913) 888-8431  
Website: [bmccranes.com](http://bmccranes.com)