

Small in size with  
big crane features

- Rated Capacity Limiter ... Standard
- Capacity on Outriggers ... 8,000 lbs (3,620 kg)
- Pick and Carry Capacity ... up to 6,700 lbs (3,040 kg)
- Height ... 6' 6" (1.98 m)
- Width ... 5' (1.52 m)
- Boom Rotation ... 360 Degree Continuous
- Sheave Height ... up to 33' (10.2 m)
- Horizontal Reach ... up to 27' (8.2 m)
- Tight Turning Radius
- Rear Wheel Steer ... Standard
- Front Wheel Drive ... Standard
- Fully Hydraulic Controls for Smooth Precise Operations
- Independent Outrigger Controls
- Dual Fuel or Diesel Available

**BRODERSON**  
Manufacturing Corp.



# IC-35-2F

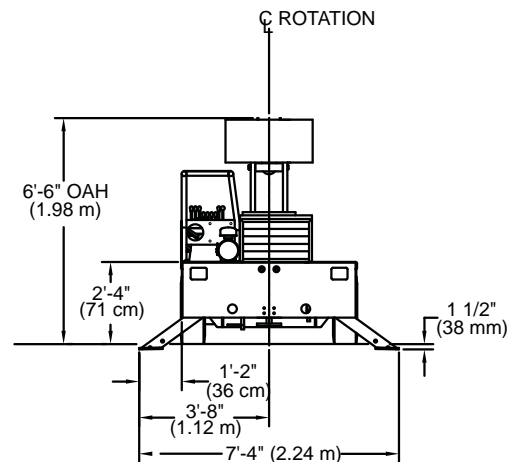
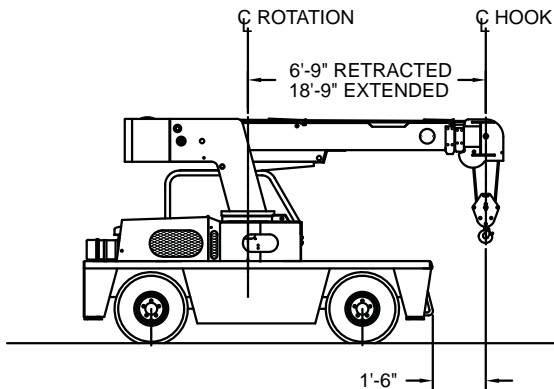
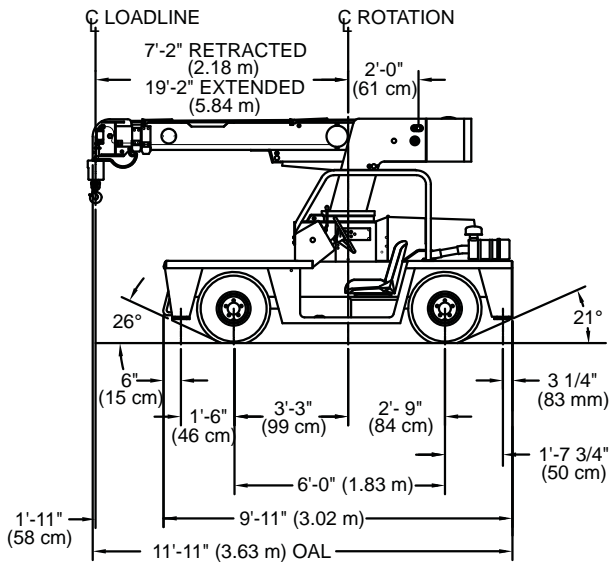
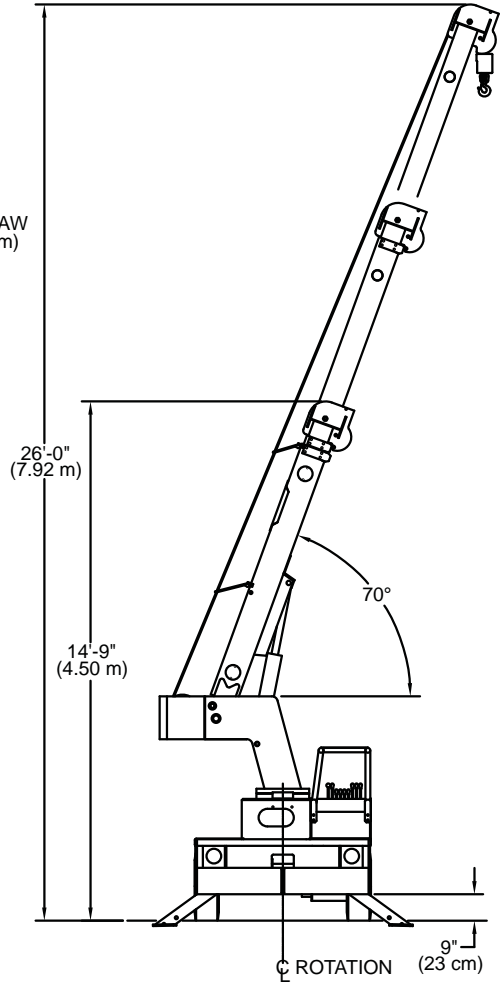
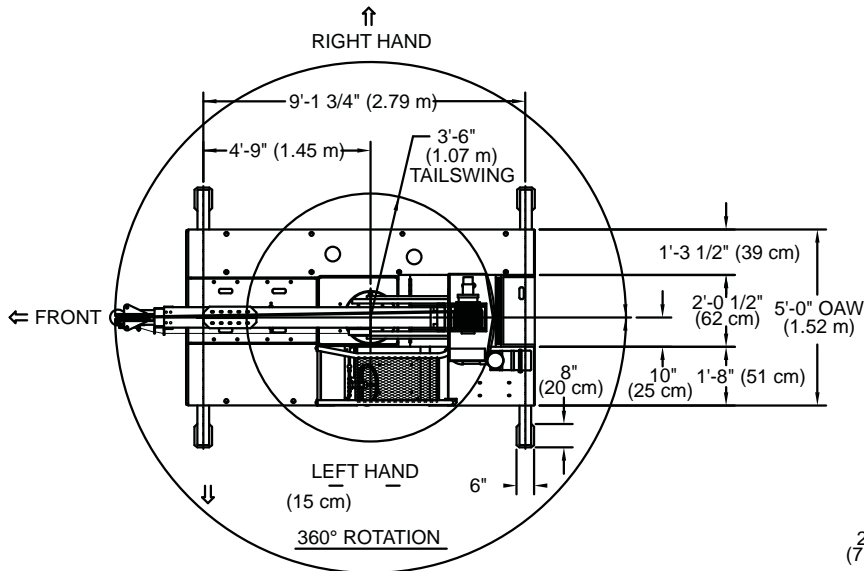

# IC-35-2F

## Specifications

### GENERAL:

<b>Weight</b>	7,860 lbs (3,565 kg)
<b>Travel Speed</b>	0 to 10 mph (0 to 16 km/h)
<b>Drawbar Pull</b>	2,120 lbs (960 kg)
<b>Gradeability:</b>	30%
<b>Boom Movement:</b>	
<b>Rotation</b>	Continuous
<b>Elevation</b>	0° to 70°
<b>Extension</b>	12 feet (3.66 m)
<b>Boom Speeds:</b>	
Rotation	1.5 RPM
Elevation	17 seconds
Extension	32 seconds

### ENGINE:

<b>Make</b>	GM	Kubota
<b>Model</b>	2.4 L EFI	V2403-M-E3B
<b>Type</b>	Dual Fuel	Diesel
<b>No. Cyl.</b>	4	4
<b>Displacement</b>	2.4 L	2.4L
<b>HP @ Gov. Speed</b>	65 HP (48 kW)	48.9 HP (36.5 kW)
<b>EPA Certification</b>	Tier 2	Tier 4
<b>Fuel Tank Capacity</b>	13.5 Gallons (51 L)	

### HYDROSTATIC PUMP:

Piston type, direct driven from engine crankshaft. Maximum flow 34 gpm (120 L/min). Max. pressure 4,000 psi (275 bar).

### AXLES:

#### Front Axle:

Channel shaped structure houses torque hubs, brakes and hydraulic drive motors. Axle oscillates a total of 1-1/2 in (38 mm).

#### Rear Axle:

Fixed rigid to frame.

### STEERING:

Full hydraulic steering unit controls 2-1/2 in. (63 mm) steering cylinder attached to rear axle.

### BRAKES:

Primary braking from hydrostatic transmission. Foot-actuated disc brake attached to each torque hub additional braking in some conditions. Parking brake switch locks brakes to hold crane when not being driven.

### TIRES:

Front: 7.5 x 10 pneumatic, 16-ply  
Rear: 7.5 x 10 pneumatic, 16-ply

### CHASSIS:

#### CARGO DECK:

29 sq. ft. (2.7 m<sup>2</sup>) of deck area. 6,000 lbs (2,720 kg) capacity on deck when load is centered over or between axles.

#### OUTRIGGERS:

Four hydraulic outriggers of box-beam construction. Independent controls for each. Hydraulic cylinders are equipped with direct-connected holding valves.

#### Lifting Rings

Lifting rings at each corner of cargo deck so sling can be attached for lifting crane.

#### Front Pulling Eye

Mounted on front bumper.

### OPERATOR COMPARTMENT:

Provides one-position access to all chassis & crane functions. Includes adjustable operator's seat, retracting seat belts, fire extinguisher & bubble level.

### ELECTRICAL:

#### 12 Volt System

#### Lighting Package:

One pair headlights and taillights.

#### Instrument Package:

Fuel, ammeter, oil pressure, water temperature gauges, hydraulic oil temperature gauge and hourmeter.

#### Back-Up Alarm:

Provides pulsating sound from 97dB alarm when transmission is in reverse.

#### Outrigger Alarm System:

112 dB, alternating two-tone alarm is activated when "outrigger down" controls are operated.

### HYDRAULIC SYSTEM:

Tandem pump mounted to rear of hydrostatic piston pump. Delivers 6 gpm (23 L/min) at 2,600 psi (179 bar) for boom circuits and 17 gpm (64 L/min) at 2,500 psi (155 bar) for hoist circuit. System protected by relief valves. Hydraulic oil reservoir has 14 gallon (53 L) capacity.

### BOOM ASSEMBLY:

Three-section boom assembly equipped with bearing pads, double-acting hydraulic cylinders extend boom. The primary extension cylinder and the double-acting boom elevation cylinder are equipped with direct connected holding valves. Boom angle indicator on side of boom.

### Boom Rotation:

Heavy-duty ball bearing rotation gear with external teeth. Rotation is powered by hydraulic motor & worm gear drive.

### Boom Hoist:

Turret mounted planetary gear hoist hydraulically powered with a bare drum line pull of 5,000 lbs (2,268 kg) & a line speed of 86 fpm (26 m). Hoist includes 85 ft (26 m) of 3/8 in (9.5 m) wire rope, downhaul weight, swivel hook and sheave block for 2-part line.

### Anti-Two-Block Device:

Prevents damage to hoist rope and/or crane components from pulling load hook against tip.

### Rated Capacity Limiter:

Operator's aid that warns operator of impending overload with audio & visual signals.

# IC-35-2F

## Options

Listed below are brief descriptions of options available for this product.  
Consult the IC-35-2F Engineering Spec for additional information.

### MODEL:

IC-35-2F Industrial Crane

### ENGINE OPTIONS:

#### Spark Arrester Muffler

Installed in addition to std. muffler.

#### Engine Shut Down Gauges

Shuts engine off when high water temperature or low engine oil pressure occurs, for diesel only.

### TIRE OPTIONS:

#### Solid Rubber Tires

#### Solid Rubber Tires, Non-Marking

#### Foam Filling of Tires

#### Spare Tire & Wheel, Pneumatic

#### Spare Tire & Wheel, Solid Rubber

#### Spare Tire & Wheel, Solid Rubber, Non-Marking

#### Foam Filling of Spare Tire

### CHASSIS OPTIONS:

#### Auxiliary Winch

Mounted behind the front bumper, hydraulically driven with control in operator's console 3,000 lbs, (1,360 kg) @ 20 fpm (6 m/min).

#### Pintle Hook - Rear

Holland "T-60-A" pintle hook mounted on rear of frame. 5-ton capacity.

#### Lifting Sling

Sling to attach to Lifting Rings.

#### Rearview Mirrors

One mounted on right-hand deck stake and one mounted on left-hand deck stake.

### OPERATOR COMPARTMENT OPTIONS:

#### All Weather Cab

Rigid-mounted canopy section and removable hinged door with safety glass. Cab door adds 4 in (102 mm) to crane on operator's side. Includes heater, electric windshield wiper, one sliding glass window in the door, & one fold out window in rear. Defroster fan & dome light included.

#### Cab Heater Only

Heater with two-speed fan for units without All Weather Cab.

#### Operator Guard

Tubular steel weldment with heavy expanded steel mesh top section for unit without All Weather Cab.

#### Operator Guard Cover

Clear vinyl cover over Operator Guard, for inclement weather.

#### Floor Mat

Vinyl mat with foam backing.

### ELECTRICAL OPTIONS:

#### Strobe Lights

Yellow strobe light mounted on each side of turret weight box.

#### Boom Work Lights

One work light mounted to boom to light boom tip and one work light mounted to turret to light ground under boom tip.

### WIRE ROPE:

140 ft (42.6 m) of 3/8 in (9.5 mm) dia. wire rope.

### BOOM ATTACHMENTS:

#### Boom Extension

8 ft (2.4 m), boom stowable.

#### Boom Extension, Offset

8 ft (2.4 m), boom stowable. Boom extension is offsettable to 3 different positions; 0 degree (in line), 15 degree and 30 degree offset.

#### Searcher Hook - Nose Mount:

2,000 lb (907 kg) capacity. Swivel hook with spring latch hangs from support structure projecting outward from boom tip.

Should you require an option or special equipment not listed please consult your dealer salesperson or BMC®.

**BRODERSON**  
Manufacturing Corp.  
14741 West 106th Street  
Lenexa, KS 66215 USA

Tel (913) 888-0606  
Fax (913) 888-8431  
www.bmccranes.com

Dimensions and values shown are  
for reference purposes only.  
Specifications subject to change.



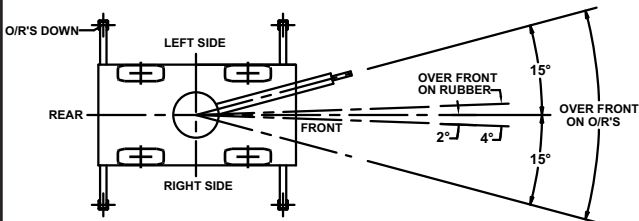
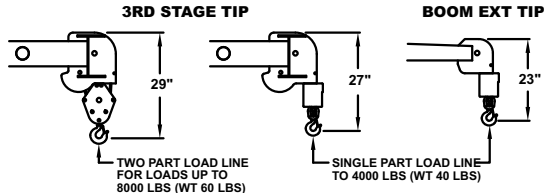
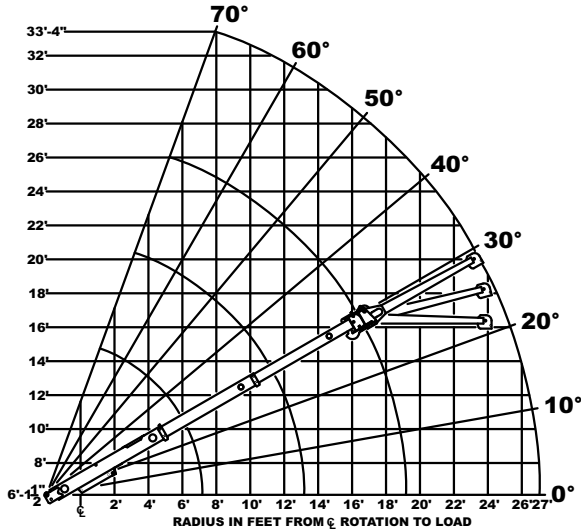

LOAD RADIUS IS THE HORIZONTAL DISTANCE FROM THE CENTER OF ROTATION OF THE UNLOADED CRANE TO THE VERTICAL LOAD LINE WITH THE LOAD APPLIED.

LOAD HOOKS, DOWNHAUL WEIGHTS, HOOK BLOCKS, AND OTHER LOAD HANDLING DEVICES EXCEPT HOIST ROPE SHALL BE CONSIDERED PART OF THE LOAD.

PICK AND CARRY WITH THE SHORTEST PRACTICAL BOOM, CENTERED OVER THE FRONT. OPERATE WITH THE BOOM AS LOW AS POSSIBLE, WITH THE LOAD CLOSE TO THE GROUND. PICK AND CARRY CAPACITIES ARE FOR SMOOTH, LEVEL PAVED SURFACE.

DECK LOAD 6000 LBS MAX, CENTERED BETWEEN WHEELS, WITH NO BOOM LOAD. DECK LOADS MUST BE CENTERED BEHIND THE FRONT AXLE. SPEED MUST BE LESS THAN 2 MPH. MAXIMUM TRAVEL 200 FT. IN 30 MINUTES.

### CAPACITIES APPLY TO OPERATION ON FIRM LEVEL SURFACE

LOAD RADIUS FEET	MAIN BOOM OR EXTENSION CAPACITIES IN POUNDS							
	360° ROTATION		OVER FRONT					
	ON RUBBER	ON OUTRIGGERS	ON RUBBER	ON OUTRIGGERS				
4	5000	8000	6700	8000				
5	4000	6800	5800	6800				
6	2850	5850	5100	5850				
8	1800	4150	3500	4150				
10	1250	3200	2350	3400				
12	900	2350	1750	2850				
14	700	1850	1350	2450				
16	600	1500	1100	2150				
18	500	1250	950	1950				
19	450	1150	900	1850				
20	400	1100	850	1600				
22	300	900	700	1450				
24	250	800	600	1300				
26	200	700	500	1150				
27	150	650	450	1100				
<b>BOOM EXTENSION</b>		<b>8-FOOT BOOM EXTENSION - STRAIGHT OR OFFSET</b>						
<b>ANGLE</b>		<b>MAIN BOOM ANGLE</b>						
	0°	10°	20°	30°	40°	50°	60°	70°
+* 0°	1100	1200	1300	1450	1600	1850	2300	3500
* 15°	—	—	1100	1250	1350	1500	1700	2050
* 30°	—	—	—	1100	1200	1300	1450	1600

+ USE 0° FOR STRAIGHT BOOM EXTENSION.

\* USE 0°, 15° OR 30° FOR OFFSET BOOM EXTENSION.

EXCEEDING CAPACITY RATINGS OR APPLYING SIDE LOADS TO THE BOOM OR BOOM EXTENSION IS MISUSE, IS HAZARDOUS, AND VOIDS WARRANTY.

CAUTION: BOOM EXTENSION LOADS MUST NOT EXCEED MAIN BOOM CAPACITY. BOOM EXTENSION DEDUCT: 100 LBS. WHEN STOWED ON BASE BOOM. DO NOT PICK & CARRY WITH LOADS ON BOOM EXTENSION. ENSURE ANTI-TWO-BLOCK SWITCH IS FUNCTIONAL AFTER DEPLOYING OR STOWING BOOM EXTENSION.

CAPACITIES ON OUTRIGGERS ARE 85% OF TIPPING LOADS. CAPACITIES ON RUBBER ARE 75% OF TIPPING LOADS. CAPACITIES BELOW **BOLD** LINE ARE LIMITED BY TIPPING. OTHER CAPACITIES ARE LIMITED BY STRUCTURAL OR HYDRAULIC CAPABILITIES.

BOOMS ON THIS UNIT ARE ALL STEEL AND HAVE NO LINE VOLTAGE RATING.

THE LOAD LINE ON THIS UNIT MUST BE 3/8 DIA. 6X36 EIP RRL IWRC WIRE ROPE (OR EQUIVALENT) WITH A MINIMUM BREAKING STRENGTH OF 15,100 LBS.

#### OPERATION:

1. READ AND UNDERSTAND OWNERS MANUAL BEFORE OPERATING THIS CRANE.
2. CHECK LEVEL OF ENGINE OIL AND HYDRAULIC OIL DAILY.
3. CHECK UNIT FOR VISIBLE DEFECTS DAILY.
4. EXTEND OUTRIGGERS FULLY IF POSSIBLE. IF NOT, USE "ON RUBBER" CHART.
5. AVOID QUICK STARTS AND STOPS WHEN OPERATING OR DRIVING CRANE.

TIRE PRESSURE: 145 PSI FOR 7.50 X 10-16PL.

MAXIMUM HYDRAULIC PRESSURE 2600 PSI.

# Metric

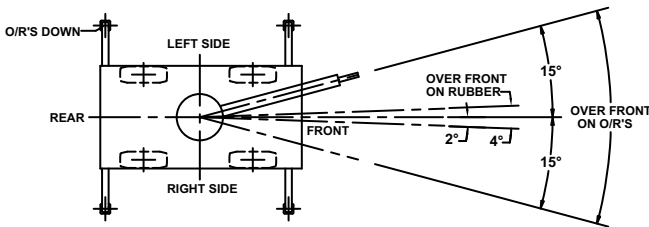
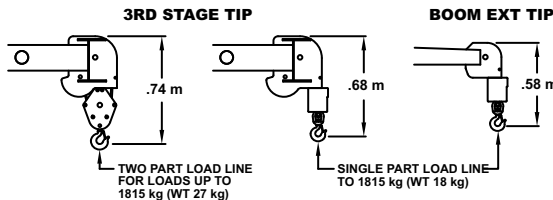
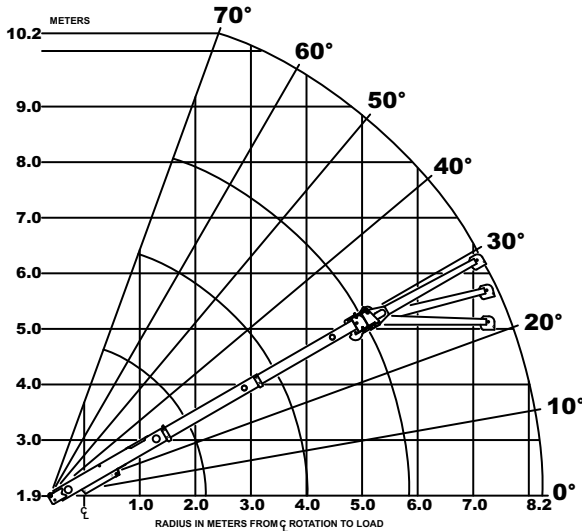

LOAD RADIUS IS THE HORIZONTAL DISTANCE FROM THE CENTER OF ROTATION OF THE UNLOADED CRANE TO THE VERTICAL LOAD LINE WITH THE LOAD APPLIED.

LOAD HOOKS, DOWNHAUL WEIGHTS, HOOK BLOCKS, AND OTHER LOAD HANDLING DEVICES EXCEPT HOIST ROPE SHALL BE CONSIDERED PART OF THE LOAD.

PICK AND CARRY WITH THE SHORTEST PRACTICAL BOOM, CENTERED OVER THE FRONT. OPERATE WITH THE BOOM AS LOW AS POSSIBLE, WITH THE LOAD CLOSE TO THE GROUND. PICK AND CARRY CAPACITIES ARE FOR SMOOTH, LEVEL PAVED SURFACE.

DECK LOAD 2720 kg MAX, CENTERED BETWEEN WHEELS, WITH NO BOOM LOAD. DECK LOADS MUST BE CENTERED BEHIND THE FRONT AXLE. SPEED MUST BE LESS THAN 3 km/h. MAXIMUM TRAVEL 60 m IN 30 MINUTES.

**CAPACITIES APPLY TO OPERATION ON FIRM LEVEL SURFACE**

LOAD RADIUS METERS	MAIN BOOM OR EXTENSION CAPACITIES IN KILOGRAMS							
	360° ROTATION		OVER FRONT					
	ON RUBBER	ON OUTRIGGERS	ON RUBBER	ON OUTRIGGERS				
1.2	<b>2260</b>	<b>3620</b>	<b>3040</b>	<b>3630</b>				
1.5	<b>1850</b>	<b>3120</b>	<b>2650</b>	<b>3120</b>				
2.0	<b>1090</b>	<b>2420</b>	<b>2120</b>	<b>2420</b>				
2.5	<b>780</b>	<b>1830</b>	<b>1520</b>	<b>1830</b>				
3.0	<b>580</b>	<b>1480</b>	<b>1090</b>	<b>1560</b>				
3.5	<b>440</b>	<b>1160</b>	<b>850</b>	<b>1350</b>				
4.0	<b>350</b>	<b>920</b>	<b>680</b>	<b>1180</b>				
4.5	<b>300</b>	<b>770</b>	<b>560</b>	<b>1050</b>				
5.0	<b>260</b>	<b>650</b>	<b>480</b>	<b>950</b>				
5.8	<b>200</b>	<b>520</b>	<b>410</b>	<b>840</b>				
6.0	<b>190</b>	<b>500</b>	<b>390</b>	<b>750</b>				
6.5	<b>150</b>	<b>430</b>	<b>340</b>	<b>680</b>				
7.0	<b>120</b>	<b>380</b>	<b>290</b>	<b>620</b>				
7.5	<b>100</b>	<b>350</b>	<b>250</b>	<b>570</b>				
8.2	<b>70</b>	<b>290</b>	<b>200</b>	<b>500</b>				
<b>BOOM EXTENSION</b>		<b>2.44 m BOOM EXTENSION - STRAIGHT OR OFFSET</b>						
<b>ANGLE</b>		<b>MAIN BOOM ANGLE</b>						
	0°	10°	20°	30°	40°	50°	60°	70°
+* 0°	<b>500</b>	<b>540</b>	<b>590</b>	<b>660</b>	<b>720</b>	<b>840</b>	<b>1040</b>	<b>1590</b>
* 15°	—	—	<b>500</b>	<b>560</b>	<b>610</b>	<b>680</b>	<b>770</b>	<b>930</b>
* 30°	—	—	—	<b>500</b>	<b>540</b>	<b>590</b>	<b>660</b>	<b>720</b>

+ USE 0° FOR STRAIGHT BOOM EXTENSION.  
\* USE 0°, 15° OR 30° FOR OFFSET BOOM EXTENSION.

EXCEEDING CAPACITY RATINGS OR APPLYING SIDE LOADS TO THE BOOM OR BOOM EXTENSION IS MISUSE, IS HAZARDOUS, AND VOIDS WARRANTY.

CAUTION: BOOM EXTENSION LOADS MUST NOT EXCEED MAIN BOOM CAPACITY. BOOM EXTENSION DEDUCT: 45 kg WHEN STOWED ON BASE BOOM. DO NOT PICK & CARRY WITH LOADS ON BOOM EXTENSION. ENSURE ANTI-TWO-BLOCK SWITCH IS FUNCTIONAL AFTER DEPLOYING OR STOWING BOOM EXTENSION.

CAPACITIES ON OUTRIGGERS ARE 85% OF TIPPING LOADS. CAPACITIES ON RUBBER ARE 75% OF TIPPING LOADS. CAPACITIES BELOW **BOLD** LINE ARE LIMITED BY TIPPING. OTHER CAPACITIES ARE LIMITED BY STRUCTURAL OR HYDRAULIC CAPABILITIES.

BOOMS ON THIS UNIT ARE ALL STEEL AND HAVE NO LINE VOLTAGE RATING.

THE LOAD LINE ON THIS UNIT MUST BE 10 mm DIA. 6X36 EIP RRL IWRC WIRE ROPE (OR EQUIVALENT) WITH A MINIMUM BREAKING STRENGTH OF 67 kN.

OPERATION:

1. READ AND UNDERSTAND OWNERS MANUAL BEFORE OPERATING THIS CRANE.
2. CHECK LEVEL OF ENGINE OIL AND HYDRAULIC OIL DAILY.
3. CHECK UNIT FOR VISIBLE DEFECTS DAILY.
4. EXTEND OUTRIGGERS FULLY IF POSSIBLE. IF NOT, USE "ON RUBBER" CHART.
5. AVOID QUICK STARTS AND STOPS WHEN OPERATING OR DRIVING CRANE.

TIRE PRESSURE: 1000 kPa FOR 7.50 X 10-16PL

MAXIMUM HYDRAULIC PRESSURE 180 bar

# Metric