

Tech Preliminary Information
Spec

RT-300-B

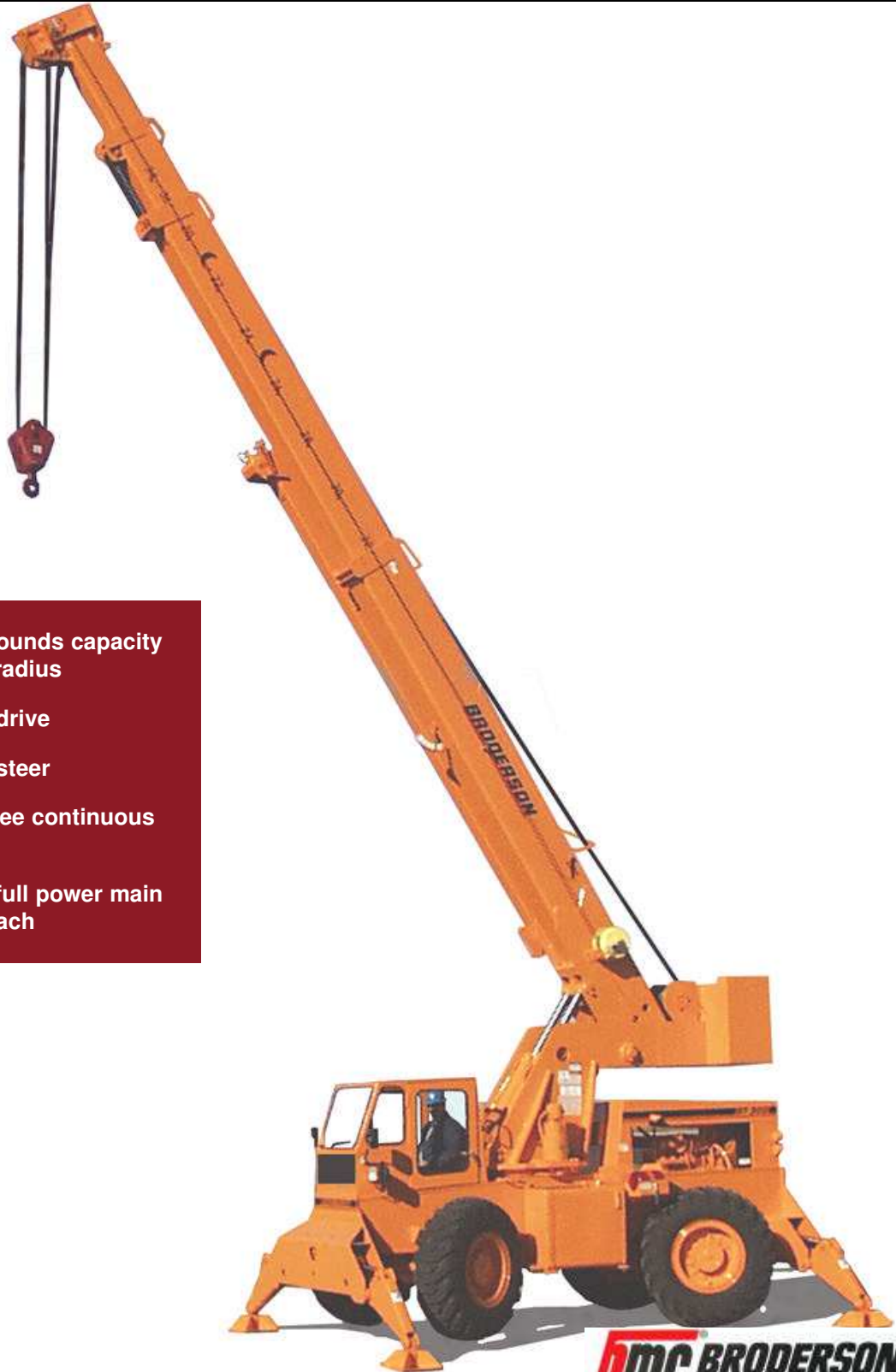

- * 30,000 pounds capacity at 10 ft. radius
- * 4-wheel drive
- * 4-wheel steer
- * 360 degree continuous rotation
- * 60 ft. of full power main boom reach

DMC BRODERSON
Manufacturing Corp.

P.O. Box 14770, Lenexa, KS 66285-4770
14741 West 106th St. • Lenexa, KS 66215-2015
(913) 888-0606 • FAX (913) 888-8431
Website: bmcrcranes.com

RT-300-2B

Preliminary Information

CAPACITIES APPLY TO OPERATION ON FIRM LEVEL SURFACE				
MAIN BOOM CAPACITIES IN POUNDS				
LOAD RADIUS FEET	360° ROTATION		OVER FRONT	
	ON RUBBER	ON OUTRIGGERS	ON RUBBER	ON OUTRIGGERS
10	19150	30000	26300	30000
12	14050	28500	22500	28500
14	11800	25950	17950	25950
16	9000	22500	14500	22550
18	7500	19500	11850	19500
20	6150	17050	9900	17050
22	5050	14550	8100	15000
24	4050	12350	6750	13300
26	3300	10550	5650	11900
28	2800	9100	4750	10650
30	2250	8000	4150	9600
32	1800	7150	3550	8600
34	1500	6400	3150	8050
36	1200	5800	2850	7500
38	1050	5350	2650	6950
40	900	4950	2400	6500
44	700	4250	1900	5600
48		3600	1600	4850
52		3150	1300	4150
56		2750	1050	3650
60		2300	850	3200
64		1950		2300
68		1750		2300
72		1500		2250
76		1300		1950
80		1100		1700

CAPACITIES ON OUTRIGGERS ARE 85% OF TIPPING LOADS - ON RUBBER 75% OF TIPPING. CAPACITIES ABOVE BOLD LINES ARE LIMITED BY STRUCTURAL OR HYDRAULIC CAPABILITIES. CAPACITIES BELOW BOLD LINES ARE LIMITED BY TIPPING. DO NOT POSITION BOOM AT LOAD RADII WHERE NO LOAD CAPACITIES ARE SHOWN.

20 FOOT - BOOM EXTENSION CAPACITIES							
BOOM EXTENSION OFFSET ANGLE	MAIN BOOM ANGLE						
	0°	15°	30°	40°	50°	60°	70°
0°	2300	2400	2700	3100	3700	4800	6200
15°	0	2300	2400	2600	2900	3400	4100
30°	0	0	2300	2400	2500	2700	3100

CAUTION: BOOM EXTENSION LOADS MUST NOT EXCEED MAIN BOOM CAPACITY.
 BOOM EXTENSION DEDUCT: 500 LBS. WHEN STOWED ON BASE BOOM.
 1000 LBS. IN WORK POSITION WITH LOAD ON MAIN BOOM.

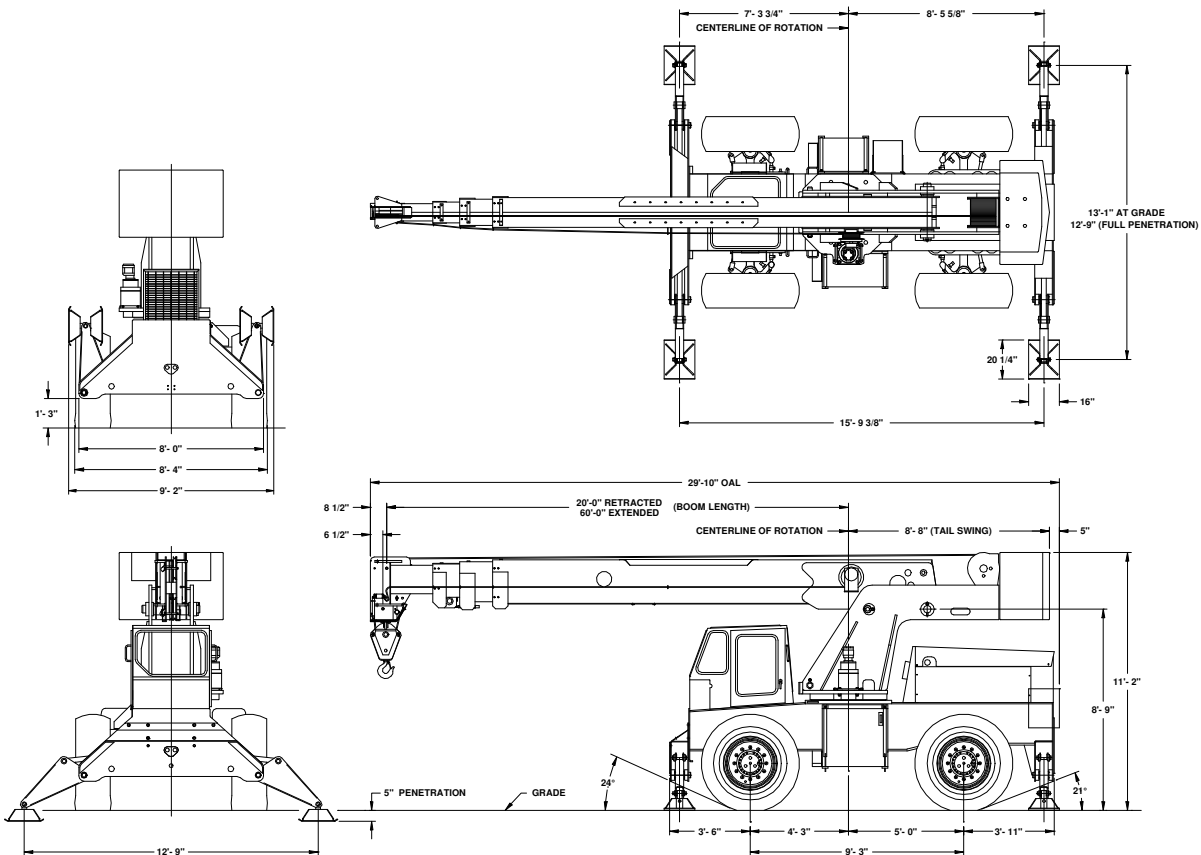
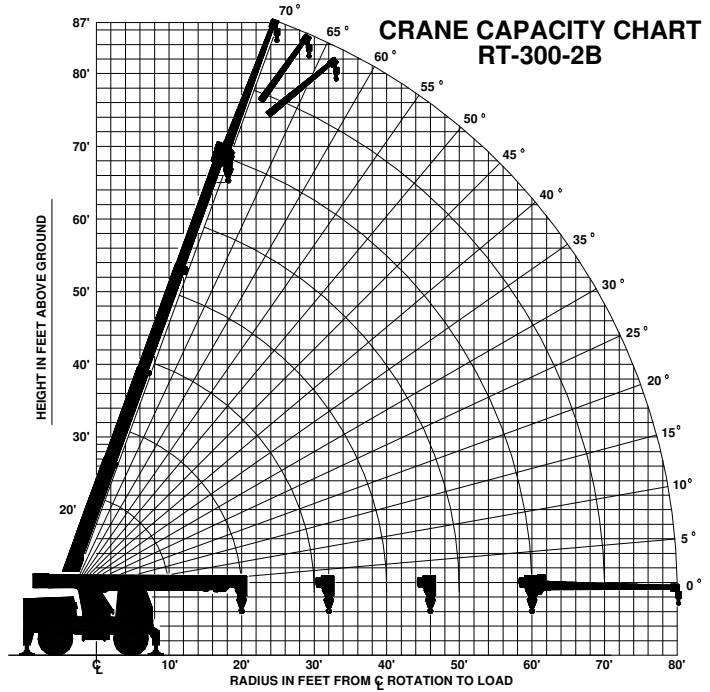

RT-300-2BO

Preliminary Information

CAPACITIES APPLY TO OPERATION ON FIRM LEVEL SURFACE						
LOAD RADIUS FEET	MAIN BOOM CAPACITIES IN POUNDS					
	360° ROTATION			OVER FRONT		
	ON RUBBER	O/R'S IN & DOWN	O/R'S OUT & DOWN	ON RUBBER	ON OUTRIGGERS	
10	18800	25500	30000	24900	30000	
12	15200	20800	28500	21400	28500	
14	11000	16000	25950	18100	25950	
16	8800	12600	22500	14300	22500	
18	7200	10300	19500	11800	19500	
20	5900	8500	17050	9700	17050	
22	4900	7100	15000	8200	15000	
24	4050	5900	13300	7000	13300	
26	3300	4900	11900	6000	11900	
28	2800	4100	10650	5100	10650	
30	2250	3500	9600	4400	9600	
32	1800	3000	8600	3800	8600	
34	1500	2600	8050	3400	8050	
36	1300	2200	7500	3000	7500	
38	1100	2000	6950	2700	6950	
40	1000	1800	6500	2500	6500	
44	700	1400	5700	2100	5700	
48	1100	1100	5000	1700	5000	
52		900	4400	1400	4400	
56		700	4000	1150	4000	
60		500	3500	900	3500	
64			2700		2700	
68			2500		2500	
72			2400		2400	
76			2100		2100	
80			1900		1900	

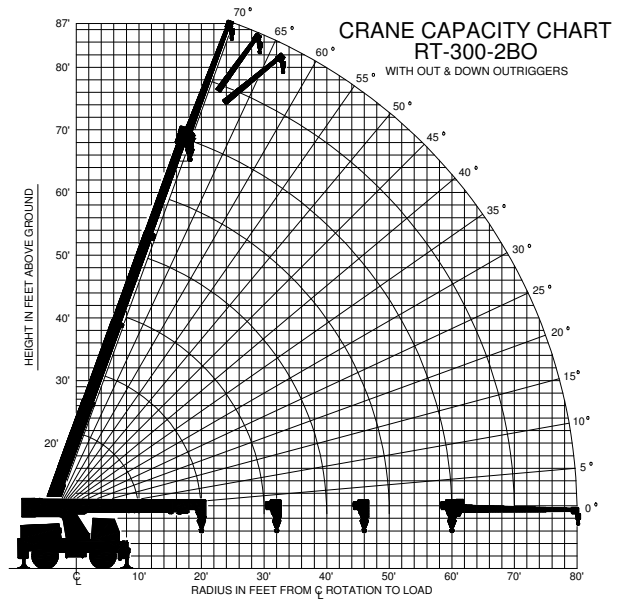

OUTRIGGERS MUST BE FULLY EXTENDED OUTWARD TO USE THE O/R'S OUT & DOWN CAPACITIES. OVER FRONT, ON RUBBER CAPACITIES ARE FOR SMOOTH PAVED SURFACE. FOR UNPAVED SURFACE REDUCE CAPACITY BY 25%. CAPACITIES ON OUTRIGGERS ARE 85% OF TIPPING LOADS - ON RUBBER 75% OF TIPPING. CAPACITIES ABOVE BOLD LINES ARE LIMITED BY STRUCTURAL OR HYDRAULIC CAPABILITIES. CAPACITIES BELOW BOLD LINES ARE LIMITED BY TIPPING. DO NOT POSITION BOOM AT LOAD RADII WHERE NO LOAD CAPACITIES ARE SHOWN.

BOOM EXTENSION OFFSET ANGLE	20 FOOT - BOOM EXTENSION CAPACITIES						
	MAIN BOOM ANGLE						
0°	2300	2400	2700	3100	3700	4800	6200
15°	0	2300	2400	2600	2900	3400	4100
30°	0	0	2300	2400	2500	2700	3100

CAUTION: BOOM EXTENSION LOADS MUST NOT EXCEED MAIN BOOM CAPACITY. BOOM EXTENSION DEDUCT: 500 LBS. WHEN STOWED ON BASE BOOM. 1000 LBS. IN WORK POSITION WITH LOAD ON MAIN BOOM.

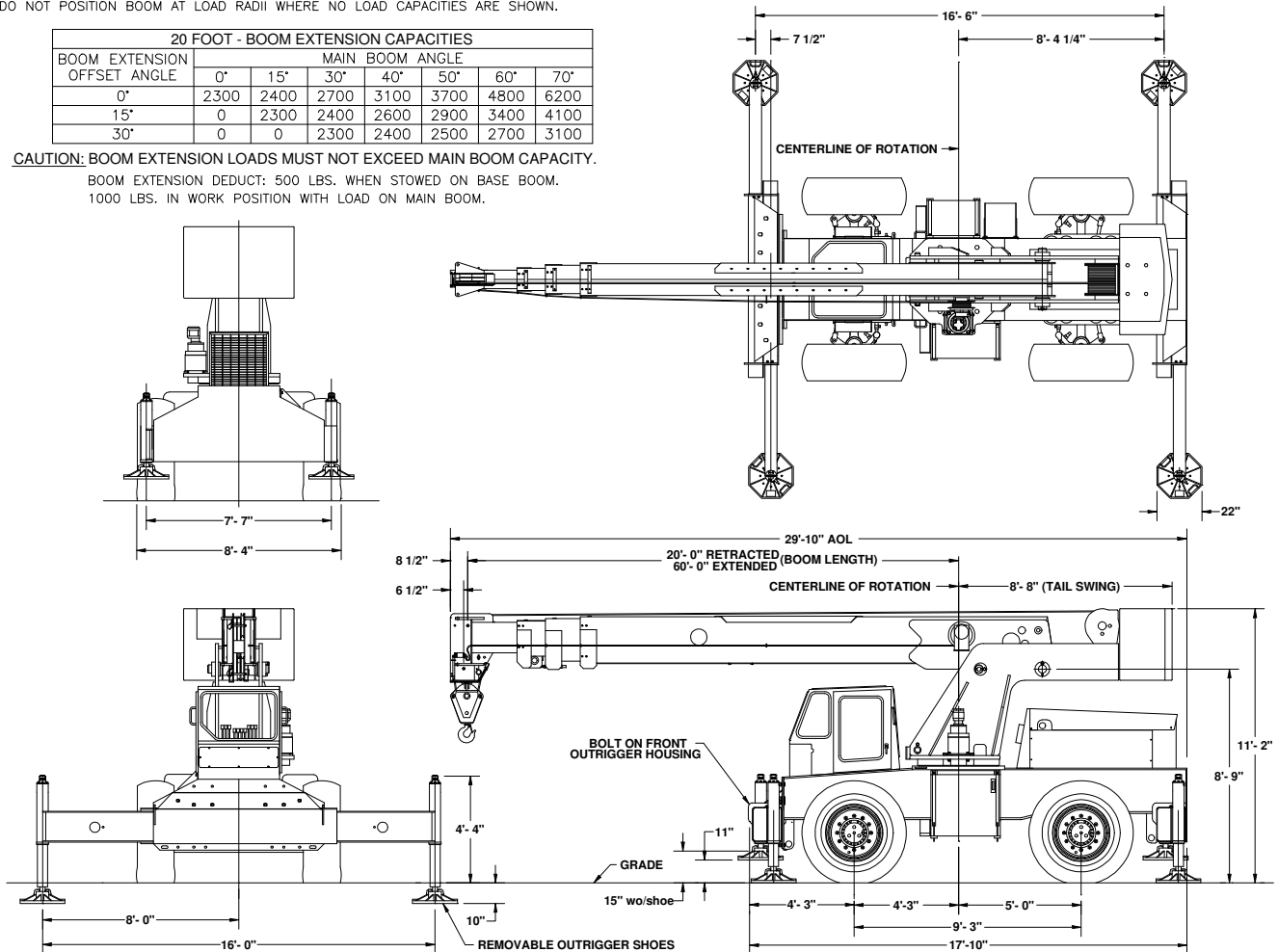

Preliminary Information

GENERAL:

Weight:	RT-300-2B	RT-300-2B0
Total	44,100 lbs.	46,500 lbs.
Front Axle	21,500 lbs.	23,210 lbs.
Rear Axle	22,600 lbs.	23,290 lbs.
Angle of Approach	26 Degrees	20 Degrees
Angle of Departure	24 Degrees	20 Degrees
Gradeability	70 Percent on Concrete	
Turning Radius: 4-Wheel Steer: (Min.)		
Outside Tire C/L Radius	14 Feet 11 Inches	
Vehicle Clearance Circle (Dia.)	34 Feet 0 Inches	
Drawbar Pull	23,400 pounds	
Road Speed	26 Miles Per Hour (Max.)	

ENGINE:	Standard	Optional
Make	John Deere	Cummins
Model	6068D	6BT5.9
Type	Diesel	Turbo Diesel
C.I.D.	414	359
Max. Torque	335 @ 1200 RPM	410 @ 1600 RPM
Rated HP	130 @ 2500 RPM	152 @ 2500 RPM
FUEL TANK:	50 Gallon Capacity	

TRANSMISSION

Make	Funk	
Model	2000	
Type	6-Speed Powershift With Torque Converter, Oil Cooler and Filter	
Gear Ratios:	Forward	Reverse
First	8.20:1	8.20:1
Second	4.64:1	3.53:1
Third	3.53:1	1.41:1
Fourth	2.00:1	
Fifth	1.41:1	
Sixth	.80:1	

AXLES:

Front and Rear Axles:

Make	Rockwell
Gear Ratio	16.67:1

BRAKES:

Service - 4-Wheel Drum Type with Hydraulic Booster
Parking - Spring-Applied and Hydraulically-Released Mounted On Transmission

STEERING:

Hydraulic steering unit with two 3.5 inch cylinders attached to each axle. Allows limited steering when engine is not running. Steering wheel and selector valve control 3-mode steering: Two-Wheel Front Axle Steer, Crab and Round.

TIRES:

Standard - 17.5 x 25, 20-Ply Rating Mud Lug.

CHASSIS:

Outriggers:

RT-300-2B:

Four independently controlled outriggers of swing-down design. Hydraulic cylinders are equipped with direct-connected holding valves.

CHASSIS: (Cont'd)

Outriggers:

RT-300-2B0:

Four independently controlled outriggers of out and down design. All cylinders are equipped with direct-connected holding valves. Foot pad dimensions are 22" octagon. Pads are removable and stow on chassis when roading crane.

OPERATOR'S COMPARTMENT:

Operator control station provides one-position access to all chassis and crane controls.

ELECTRICAL SYSTEM:

12 Volt DC System

Instrument Group:

Fuel, transmission oil temperature, ammeter, engine oil pressure, water & hydraulic oil temperature gauges and hourmeter.

HYDRAULIC SYSTEM:

Triple vane pump, mounted and driven by main transmission. Rated 9, 26 and 44 GPM at 3,000 PSI at 2,500 RPM engine speed. Hydraulic oil tank capacity of 70 gallons.

BOOM ASSEMBLY:

	Boom Movement	Boom Speeds
Rotation	Continuous	3.5 RPM
Elevation	0 - 70 Degrees	15 Seconds
Extension	40 Feet	22 Seconds

Boom Assembly:

Boom assembly equipped with bearing pads. Double-acting hydraulic cylinders, equipped with a holding valve, extend and retract the second and third boom sections. Double runs of high strength leaf chain extend and retract the fourth section. Boom length markings and boom angle indicator included on each side of boom. Twin, double-acting hydraulic cylinders control the boom elevation and are equipped with direct-connected holding valves.

Boom Rotation:

Heavy-duty ball bearing rotation gear with external teeth. Rotation is powered by hydraulic motor and compound planetary gear drive. A spring-applied hydraulically released brake and an overrunning load valve are provided. Hydraulic centerpost and electric slip rings allow continuous rotation.

Boom Hoist:

Turret Mounted	
Hydraulic Powered	
Bare Drum Line Pull	10,000 Pounds
Wire Rope	375 Feet of 1/2 inch dia.
Line Speed:	
Bare Drum	320 FPM
Full Drum	412 FPM

4-Part-Line Sheave Block:

Double sheave block for four-part-line requirements.

Anti-Two-Block Device:

Prevents damage to hoist rope and/or machine components from accidentally pulling load hook against boom tip.

Preliminary Information

Listed below are brief descriptions of each option available for the RT-300-2B Rough Terrain Crane. Consult the RT-300-2B Engineering Spec for additional information on each option.

RT-300-2B - Rough Terrain Crane with Fold Down Outriggers.

RT-300-2BO - Rough Terrain Crane with Out and Down Outriggers.

ENGINE OPTIONS:

Cummins Diesel Engine

Model 6BT5.9 Turbocharged diesel engine.

Engine Heater

Engine coolant heater installed to circulate warm water through engine, plugs into 120 volt AC.

Ether Injection System

Ether starting aid controlled by switch in operator's compartment and injects ether directly into intake manifold.

Engine Shutdown Gauges

Shuts engine off when high water temperature or low engine oil pressure occurs.

Engine Side Covers

Quick detach, to fit fixed hood and grille.

TIRE OPTIONS:

Spare Wheel & Tire:

17.5 x 25, 20-Ply Tire

CHASSIS OPTIONS:

Auxiliary Front Winch

Mounted on front outrigger housing, hydraulically driven with control in operator's compartment. Requires Overhead Guard Option.

Auxiliary Front Winch Plumbing

Control valve and all plumbing to quick connect fitting at front of chassis for auxiliary front winch. Requires Overhead Guard Option.

Lifting Eyes

Lifting eyes on corners of chassis and turntable so slings can be attached for lifting crane.

Towing Eyes

Consists of four eyes, two on front and two on rear for towing.

Spreader Bar & Sling Assembly:

Spreader bar with four wire rope assemblies to allow balanced lifting of crane. Must be used with lifting eyes (ordered separately).

Pintle Hook, Front

Pintle hook mounted on front outrigger housing, 24 ton capacity. Not available with front winch option.

CHASSIS OPTIONS: (Cont'd)

Pintle Hook, Rear

Pintle hook mounted on rear outrigger housing, 24 ton capacity.

OPERATOR'S COMPARTMENT

OPTIONS:

All Weather Cab

Consists of rigid-mounted canopy section and two removable hinged doors. Includes heater with two-speed fan, 12-volt electric windshield wiper. Defroster fan included.

Window Wiper - Top Window

12-volt electric wiper on top window operated with its own switch.

Operator Guard

Tubular steel weldment with heavy expanded steel mesh top & grille front section.

Operator's Suspension Seat

Seats Inc. - Cloth

Full-suspension with adjustments for height, tilt, fore/aft, operator weight with armrest angle adjustment.

Operator's Suspension Seat

Seats Inc. - Vinyl

Full-suspension with adjustments for height, tilt, fore/aft, operator weight with armrest angle adjustment.

Operator's Suspension Seat

Grammer

Full-suspension with adjustments for height, tilt, fore/aft, operator weight, lumbar support with armrest angle adjustment.

Noise Reduction Kit

Consists of noise reduction panel over control valves and grille on front of unit to vent heat from valve area.

Air Conditioning

Air Conditioning with R134 coolant.

ELECTRICAL OPTIONS:

Outrigger Alarm System

Two-tone alarm is activated when "outrigger down" controls are operated.

Strobe Light

Yellow strobe light mounted on top of engine hood for high visibility.

Lighting Kit

Includes two modular, dual-beam headlights with turn signal lights. Taillights with brake & turn signal lights. Back-up lights & lights installed in back of instrument gauges.

ELECTRICAL OPTIONS: (Cont'd)

Amber Rotating Beacon

Amber rotating beacon mounted on top of engine hood for high visibility.

Boom Work Lights

One halogen work light mounted to boom to light boom tip and one work light mounted to turret to light ground under boom tip.

BOOM ATTACHMENT OPTIONS:

Angle Indicator

Large pointer and quadrant located under boom, in addition to standard indicators.

20 Ft. Offsettable Boom Extension

Boom stowable. Offsets include 0 (in-line), 15 or 30 degree. Downhaul weight & hook option required.

Downhaul Weight & Hook

Downhaul weight & 5-ton swivel hook to use with existing wedge socket on 1/2 inch or 9/16 inch load line.

Wire Rope - Spin Resistant

9/16 inch dia., rotation-resistant load line, 450 feet long. Includes 5-part adapter for existing 4-part sheave block.

Load Moment Indicator

Warns operator of impending overload with audible and visual signals. Prevents overload by stopping boom functions that cause overloads. Readouts for load, boom angle, boom length and load radius.

Load Indicator

Includes 3-sheave load sensor on top of boom and readout box on top of instrument panel.

Should you, as the end user, require an option or special equipment on your RT-300-2B or RT-300-2BO that is not listed on our sales literature, please contact your dealer salesperson or the factory to receive a special quoted price.

RT-300-B

Preliminary Information



IC-20



IC-35



IC-80



IC-200-3D

DMC BRODERSON
Manufacturing Corp.

P.O. Box 14770, Lenexa, KS 66285-4770
14741 West 102nd St. • Lenexa, KS 66215-2015
(913) 888-0606 • FAX (913) 888-8431
Website: bmcranes.com