

RT-300-G **Rough Terrain Crane**

The RT-300 has a rugged, heavy-duty, field proven design, and now has improved operator access and cab entry. This crane delivers higher pick capability, longer reach, greater hydraulic output and precise operator control.

Capacity

30,000 lbs. (13,600 kg)

Sheave Height

87' 11" (26.8 m)

Horizontal Reach

80' (24.38 m)

Height

11' 2" (3.4 m)

Width

8' 4" (2.54 m)



RT-300-G

SPECIFICATIONS

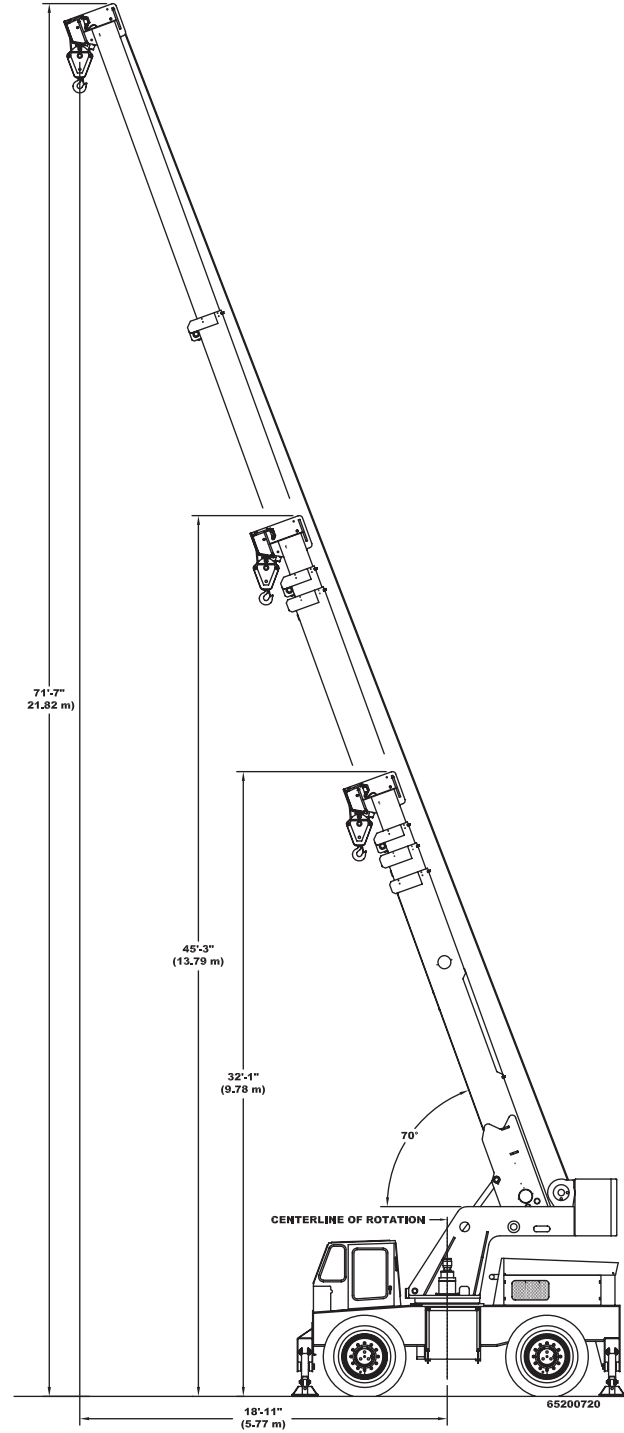
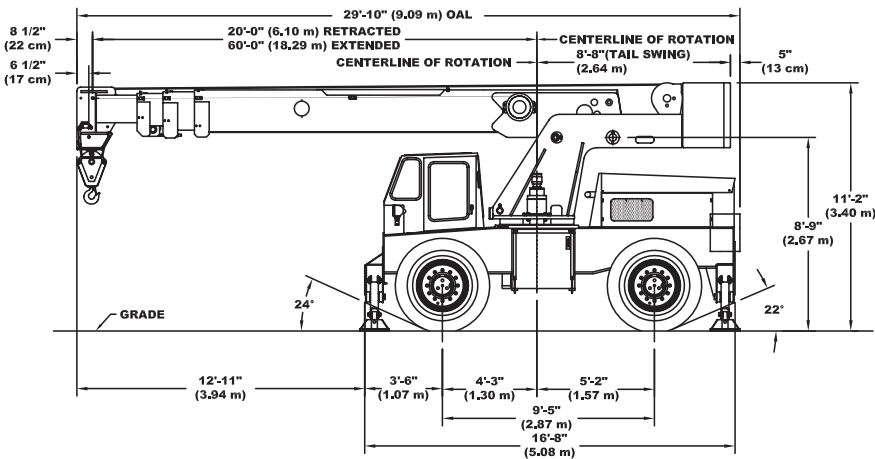
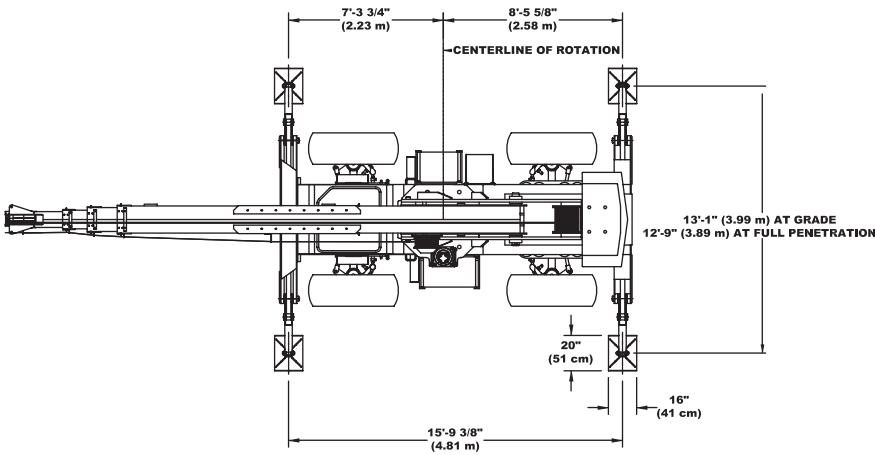
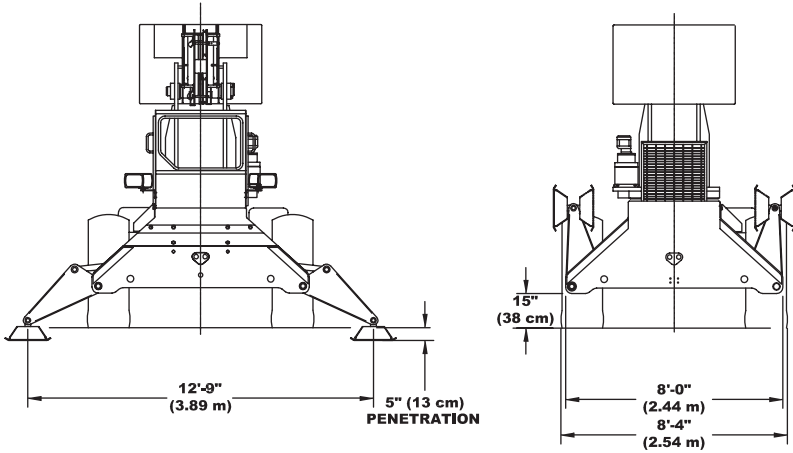

CONSULT THE RT-300-G ENGINEERING SPEC FOR ADDITIONAL INFORMATION.

Main Features

RATED CAPACITY LIMITER
Standard

CAPACITY ON OUTRIGGERS
30,000 lbs. (13,600 kg)

PICK AND CARRY CAPACITY
up to 18,300 lbs. (8,300 kg)

HEIGHT
11' 2" (3.4 m)

WIDTH
8' 4" (2.54 m)

BOOM ROTATION
360° Continuous

SHEAVE HEIGHT
up to 87' 11" (26.8 m)

HORIZONTAL REACH
up to 80' (24.38 m)

FOUR-WHEEL STEER
Standard

FOUR-WHEEL DRIVE
Standard

POWERSHIFT TRANSMISSION
Standard

**FULLY HYDRAULIC CONTROLS FOR
SMOOTH, PRECISE OPERATIONS**

**INDEPENDENT OUTRIGGER
CONTROLS**

DIESEL ENGINE
Standard

MODEL
RT-300-G Rough Terrain Crane

TIRE OPTIONS
Spare Tire & Wheel
17.5 x 25, 20-Ply Tire

CHASSIS OPTIONS
Fenders
Four bolt on steel fenders over tires.
Auxiliary Front Winch
Planetary gear winch mounted on front outrigger frame, with single-lever control on the operator console. Operator Guard required.

Lifting Eyes
Lifting eyes on corners of the chassis and the turntable so slings can be attached for lifting crane.

Towing Eyes
Consists of four eyes, two on the front and two on the rear for towing.

Pintle Hook, Front
Pintle hook mounted on the front outrigger housing, 24-ton capacity.

Pintle Hook, Rear
Pintle hook mounted on the rear outrigger housing, 24-ton capacity.

ELECTRICAL OPTIONS

Strobe Lights
Yellow strobe light mounted on top of engine hood for high visibility.

Boom Work Lights
One halogen work light mounted to boom to light boom tip and one work light mounted to turret to light ground under boom tip..

OPERATOR COMPARTMENT

Window Wiper - Top Window
12-volt electric wiper on top window operated with its own switch.

Operator Guard
Tubular steel weldment with heavy expanded steel mesh top & grille front section

Operator Suspension Seat
Seats Inc. - Cloth
Full-suspension with adjustments for height, tilt, fore/aft, operator weight with armrest adjustment.

Seats Inc. - Vinyl
Full-suspension with adjustments for height, tilt, fore/aft, operator weight with armrest adjustment.

Floor Mat
Vinyl mat with foam backing

Air Conditioning
Air Conditioning with R134 coolant.

BOOM ATTACHMENTS:

20-Ft Offsettable Boom Extension
Boom stowable. Offsets include 0 degree (in line), 15 degree or 30 degree.

Broderson Cranes are designed and built to ISO 9001:2008 certified standards and have a market leading reputation for quality and reliability. Broderson Cranes are engineered for operating efficiency and are easy to operate and maintain.

An extensive network of full-service dealers offer parts and service support by factory-trained technicians.

For additional options or special equipment not listed, please consult your dealer salesperson or contact Broderson Manufacturing Corp.

BRODERSON[®]
Manufacturing Corp.
14741 West 106th Street
Lenexa, KS 66215 USA

(913) 888-0606
www.BMCcranes.com

Dimensions and values shown are for reference purposes only. Specifications subject to change.



RT-300-G

SPECIFICATIONS

	ROTATION	ELEVATION	EXTENSION
Boom Movement	Continuous	0° to 75°	40' (12.19m)
Boom Speeds	3.5 RPM	22 sec	25 sec

GENERAL

Weight Total	44,800 lbs. (20,320 kg.)
Front Axle	23,730 lbs. (10,310 kg.)
Rear Axle	22,070 lbs. (10,010 kg.)
Drawbar Pull	30,000 lbs. (13,600 kg.)
Gradeability	70% (35°)
Turning Radius	4-Wheel Steer: (Min.) Outside Tire C/L Radius: 15' 7" (4.75 m) Vehicle Clearance Circle (Dia.): 35' 2" (10.72 m)

ENGINE

Make	Cummins
Model	QSB4.5L (Tier 4i, Tier III Available)
Type	Turbo Diesel, Charge Air Cooled
C.I.D.	4.5L
Max Torque	468 ft. lbs. (635 Nm) @ 1500 RPM
HP @ Gov. Speed	163 HP (125 kW) @ 2500 RPM
Fuel Tank Capacity	50 gal. (190L)

TRANSMISSION

6-SPEED POWERSHIFT WITH TORQUE CONVERTER, Oil Cooler and Oil Filter

AXLES

FRONT & REAR AXLES
Gear Ratio: 16.42:1

BRAKES

Service: 4-wheel hydraulic disc-type brakes
Parking: Disc-type spring-applied & hydraulically released

STEERING

Hydraulic steering unit with two cylinders attached to each axle. Allows limited steering when engine is not running. A switch on the control panel is used to select rear-wheel steering, 4-wheel steering or crab steering. Electronic sensors and control box automatically align the steering after a new mode is selected.

TIRES

Standard:
17.5 x 25, 20-ply rating, mud lug.

CHASSIS

OUTRIGGERS
Four independently controlled outriggers of swing-down design. Hydraulic cylinders are equipped with direct connected holding valves.

OPERATOR COMPARTMENT

Operator control station provides one-position access to all chassis and crane controls.

ALL WEATHER CAB

Consists of rigid-mounted canopy section and two removable hinged doors with safety glass. Includes heater with two-speed fan, 12-volt power outlet and defroster fan.

ELECTRICAL (12-VOLT SYSTEM)

INSTRUMENT GROUP

Fuel, transmission oil temperature, voltmeter, engine oil pressure, water & hydraulic oil temperature gauges, & hourmeter.

LIGHTING KIT

Includes dual-beam headlights with turn signal lights. Taillights with brake & turn signal light. Back-up lights.

OUTRIGGER ALARM SYSTEM

102 dB alarm with alternating two-tone sound is activated when "outrigger down"

HYDRAULIC

TRIPLE GEAR PUMP mounted on and driven by the main transmission, delivers 14, 28 and 40 gpm (53, 106 and 151 L/min) at 3,000 psi (207 bar) and 2,500 rpm engine speed. Hydraulic oil tank capacity of 70 gallons (265L).

BOOM ASSEMBLY

Boom assembly equipped with bearing pads. Double-acting hydraulic cylinders, equipped with a holding valve, extend & retract the second and third boom sections. Double runs of high strength leaf chain extend & retract the fourth section. Boom angle indicator included on left side of boom. Twin, double-acting hydraulic cylinders control the boom elevation & are equipped with direct-connected holding valves.

BOOM ROTATION

Heavy-duty ball bearing with external teeth rotation gear. Rotation is by hydraulic motor and compound planetary gear drive. A spring-applied hydraulically released brake and an over-running load valve are provided. Hydraulic centerpost and electric slip rings allow continuous rotation.

BOOM HOIST

Turret Mounted / Hydraulic Powered
Bare Drum Line Pull: 13,100 lbs (5,940 kg)
Wire Rope: 350 ft (107 m) of 9/16 in (14 mm) dia
Line Speed: Bare Drum - 185 fpm (56 m/min) Full Drum - 240 fpm (73 m/min)

4-PART-LINE SHEAVE BLOCK:

Double sheave block for four-part-line requirement. Downhaul weight and hook included - Standard.

ANTI-TWO-BLOCK DEVICE:

Prevents damage to hoist rope and/or machine components from accidentally pulling load hook against boom tip.

RATED CAPACITY LIMITER:

Warns operator of impending overload with audible & visual signals. In the event of overload, stops boom functions that increase overloads. Displays boom length, angle, load radius, load & capacity.