

Bronto Skylift S 70 XR

Data sheet



Technical data

- Max. working height 70 m
- Max. outreach 37 m
- Max. up and over 18 m
- Max. cage load 700 kg
Extendable cage 600 kg
- Typical chassis GVW 32 t
- Max. permitted wind speed 12,5m/s

Features

- Variable jacking
- Automatic levelling
- Easy and precise control system
- Sky jib with automatic and manual operation
- Variety of optional equipment
- Spare part available for at least 25 years
- skyliftfleet.com
- Bronto Compass remote diagnostics

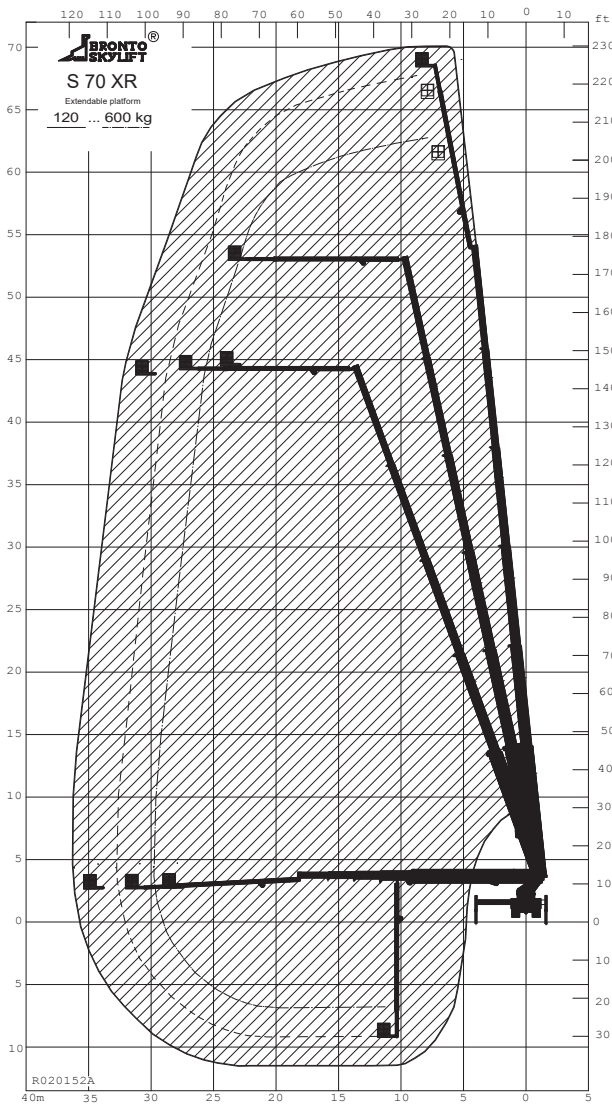

Optional equipment

- Extendable working cage with hydraulic extension up to 3,7 meters
- CW-400, detachable winch in the working cage 400 kg and winch arm slewing +/- 45 degrees (only for materials).
- BW-1100, boom winch mounted in the end of the 1st boom (mechanical structure, electricity and winch). Capacity 1100 kg. (only for materials)
- Ultrasonic collision guard, 4 sensors
- B-RCC, Rotating camera cage
- Element lifting system. 1 pc capacity 150 kg.
- Lighting rig, capacity 300 kg
- B-WRC Wireless Remote Control
- A 6,5 kVA (230 V / 400 V / 50Hz) hydraulically driven generator.
- Bronto Loadman, portable device for measuring the bearing capacity of ground.
- Electric motor drive for the hydraulics
- Round ground pads

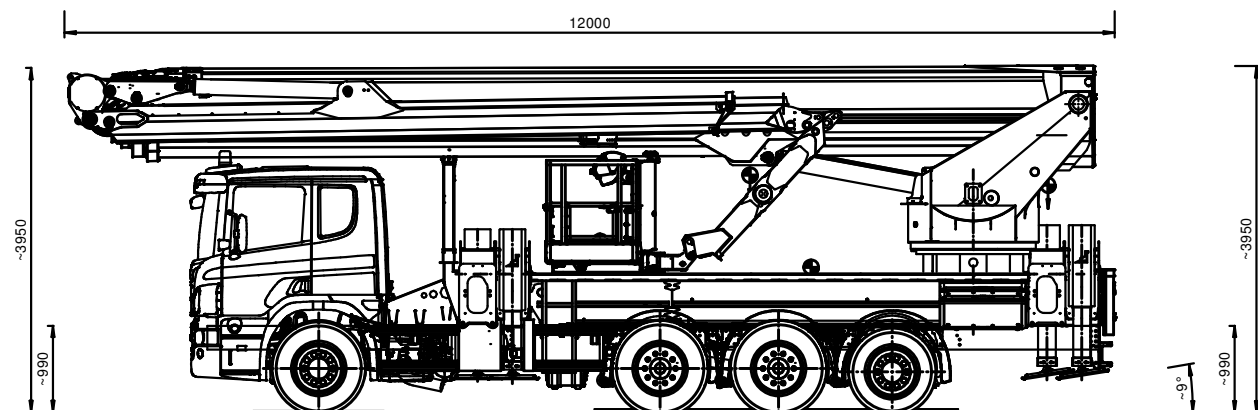

www.brontoskylift.com

e-mail: sales@brontoskylift.com

Technical data and illustrations subject to change without notice

