



casagrande



Hydraulic piling rig
Attrezzatura idraulica per pali

B180HD

Courtesy of Machine.Market

Dati tecnici

Technical Specifications

B180HD



Prestazioni Pali	Piling		
Profondità max.	Max. depth	223 ft	68 m
Diametro max.	Max. diameter	71/87* in	1800/2200* mm
Diametro max. con morsa	Max. diameter with oscillator	59 in	1500 mm
Elica continua C.F.A.	C.F.A. continuous flight auger		
Diametro max. Ø	Max. diameter Ø	39 in	1000 mm
Profondità max.	Max. depth	74 ft	22700 mm
Profondità max. con pulitore elica	Max. depth with auger cleaner	71 ft	21700 mm
Forza max. di estrazione	Max. extraction force	143,880 lbs	640 kN
Argano principale uso Kelly	Kelly main winch		
Tiro max.	Max. line pull	25,180 lbs	112 kN
Velocità max. fune	Max. line speed	410 ft/min	125 m/min
Diaframmi	Diaphragm wall		
Profondità max.	Max. depth	108 ft	33 m
Larghezza max. diaframma	Max. width of trench	47 in	1200 mm

* Sotto mast / Under mast element

Caratteristiche Carro	Undercarriage		
Larghezza cingoli chiusi	Width with retracted tracks	8.2 ft	2500 mm
Larghezza cingoli aperti	Width with extended tracks	12.8 ft	3900 mm
Lunghezza cingoli	Track length	17 ft	5190 mm
Larghezza pattini	Shoes width	27.5 in	700 mm
Motore	Engine	Cummins QSC 8.3 C (EPA/COM III)	
Potenza a 2200 rpm	Power at 2200 rpm	305 HP	227 kW
Argano principale	Main winch		
Tiro max.	Max. line pull	44,962 lbs	200 kN
Velocità max. fune	Max. line speed	295 ft/min	90 m/min
Argano ausiliario	Auxiliary winch		
Tiro max.	Max. line pull	15,737 lbs	70 kN
Velocità max. fune	Max. line speed	318 ft/min	97 m/min
Testa rotary	Rotary head	H22.20	
Coppia max.	Max. torque	132,761 lb ft	180 kNm
Velocità max. lavoro	Max. drilling speed	34 rpm	34 rpm
Velocità di scarico	Discharge speed	120 rpm	120 rpm
Martinetto pull-down	Crowd ram		
Tiro max.	Max. line pull	47,435 lbs	211 kN
Spinta max.	Max. crowd	28,100 lbs	125 kN
Corsa	Stroke	19.7 ft	6000 mm
Argano pull-down	Crowd winch		
Tiro max.	Max. line pull	54,000 lbs	240 kN
Spinta max.	Max. crowd	54,000 lbs	240 kN
Corsa	Stroke	45 ft	13700 mm
Peso	Weight		
Attrezzatura in condizioni di lavoro	Weight in working condition	~62 ton	~63 t

Tutti i dati riportati su questo catalogo sono indicativi e non considerano perdite di carico. Tali dati possono variare senza preavviso.
All data contained in this brochure are indicative and does not take power losses into account. All data can be changed without notice.



B180HD

Composizioni generali e dimensioni General arrangement and dimensions

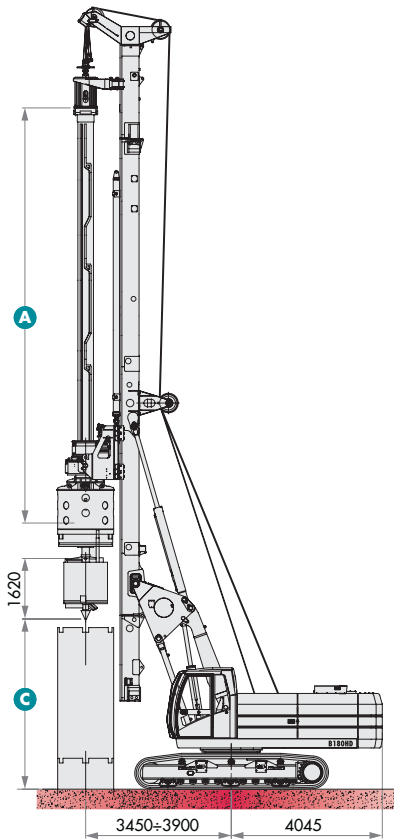

Martinetto pull - down
Crowd ram

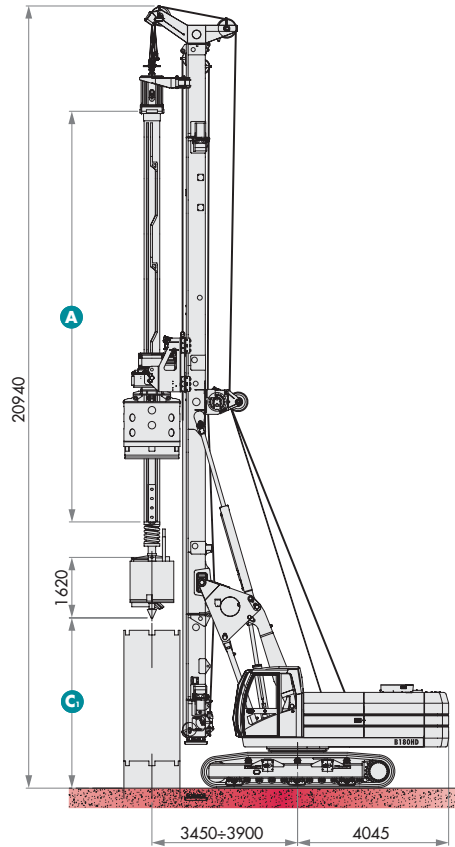

Argano pull - down
Crowd winch

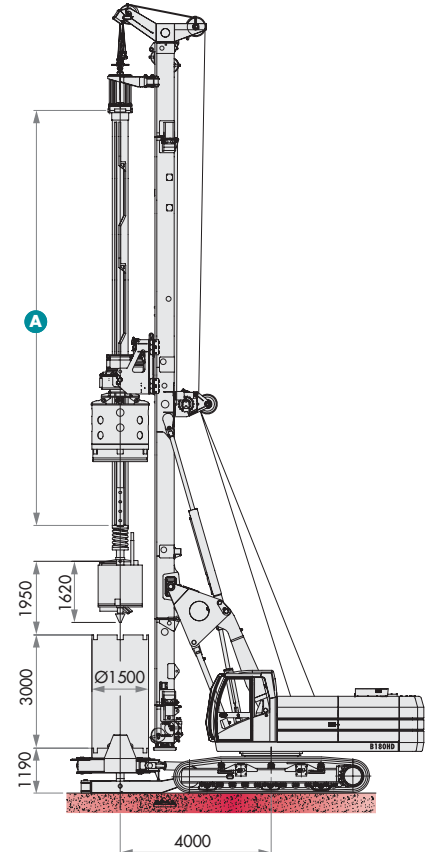

Applicazione Morsa Giracolonna
Casing Oscillator Application

Profondità di scavo • **Drilling depth**

		7500	9500	11000	12500	14500
A	Lunghezza nominale aste <i>Nominal kelly bars length</i>					
	Aste bloccaggio - 4 elementi <i>Interlocking type kelly bar - 4 elements</i>	mm 25900	33900	39900	45900	53900
		ft 85	111	131	151	177
P	Aste a frizione - 5 elementi <i>Friction type kelly bar - 5 elements</i>	mm 32950	42950	50450	57950	67950
		ft 108	141	165	190	223
G	Altezza max. utensile da terra <i>Max. ground clearance</i>	mm 5650	5650	4550	3050	1050
		ft 18.5	18.5	15	10	3.5
C	Altezza max. utensile da terra <i>Max. ground clearance</i>	mm 8050	6050	4550	3050	1050
		ft 26.4	19.8	15	10	3.5

* Aste 14500 da utilizzare con prolunga mast 2510 mm / Kelly bars L=14500 to be used with 2510 mm mast extension



B180HD

Allestimento elica continua C.F.A C.F.A. continuous flight auger

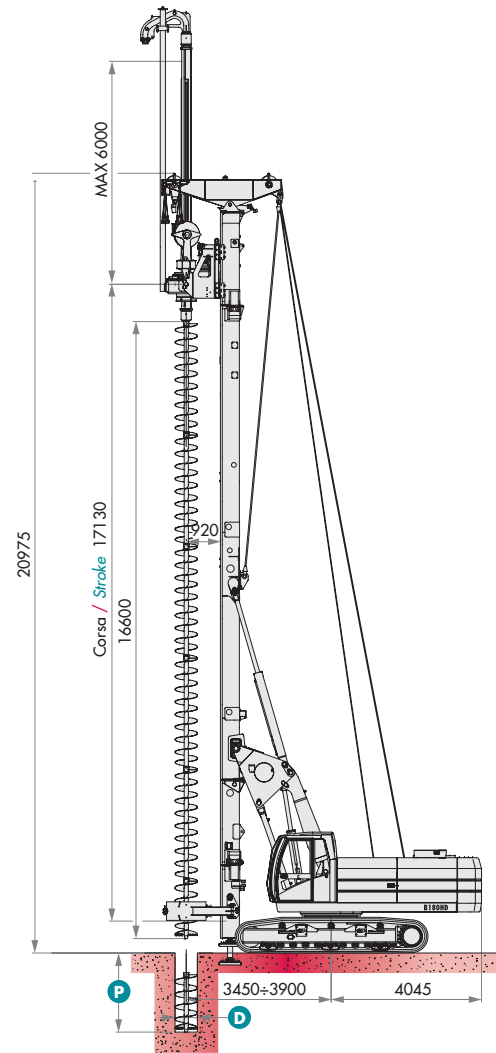

D	Diametro max. <i>Max. diameter</i>	mm	1000
		ft	39
P	Profondità max. <i>Max. depth</i>	mm	22700
		ft	74
	Forza di estrazione <i>Extraction force</i>	kN	640
		lbf	144,000
	Argano pull down* <i>Crowd winch*</i>	kN	49
		lbf	11,000

*Optional / *Optional*

Fase di trasporto • *Transport mode*

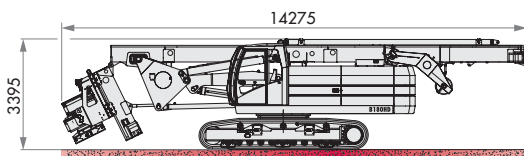

Versione pali
Piling arrangement

Peso ~ 54 t
Weight ~ 53 ton

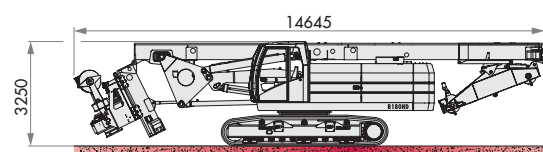

Versione CFA
CFA arrangement

Peso ~ 55 t
Weight ~ 54 ton

Allestimento diaframmi KRC2-180° KRC2-180° diaphragm

B180HD

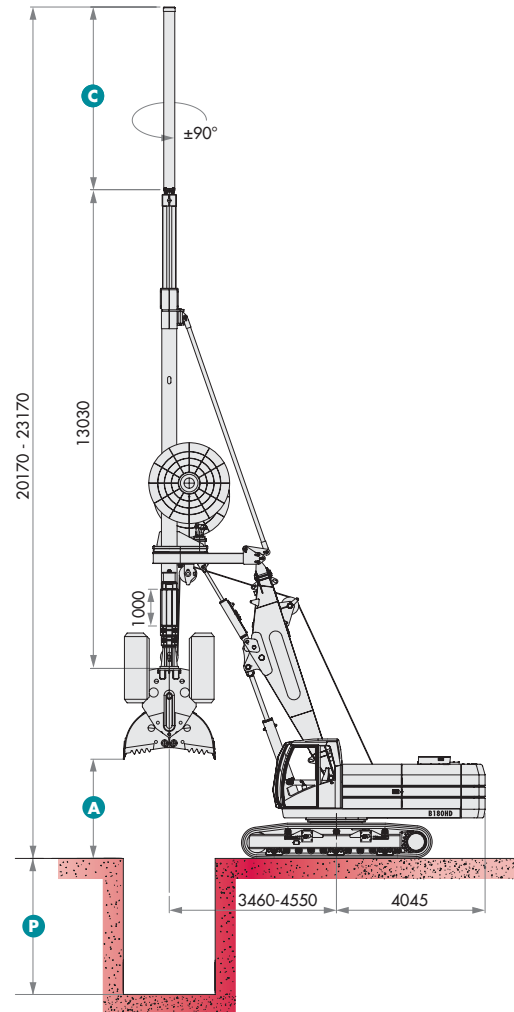

Benna idraulica • Hydraulic Grab

	K 2200	K 2500 HD	K 3000
A Altezza da terra a valve chiuse / Height with closed jaws	2450 / 8	1950 / 6.4	1450 / 4.7
C Prolunga / Extension			
-	27,7/90.9	28,2/92.5	28,5/93.5
2000	29,7/97.4	30,2/99	30,5/100
5000	32,7/107	33,2/109	33,5/110

Fase di trasporto • Transport mode

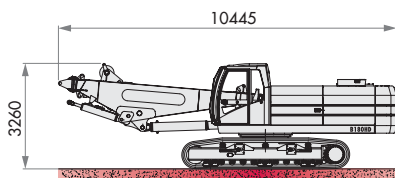

Versione Kelly
Kelly arrangement

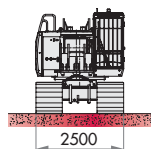

Peso ~ 45,7 t
Weight ~ 45 ton

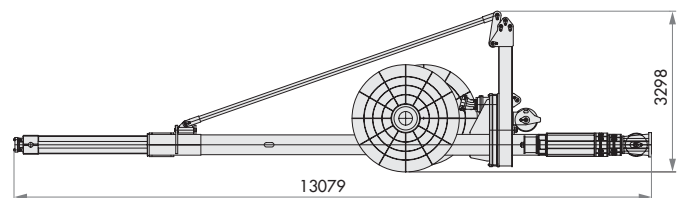

Peso ~ 15 t
Weight ~ 14.7 ton



OPTIONAL

Condizionatore/riscaldatore per cabina
 Kit per avviamento alle basse temperature
 Impianto per l'ingrassaggio automatico
 Kit luci supplementari
 Pompa per idropulitura completa di accessori
 Telecamera a colori con monitor da 5,6' per controllo tamburo argano principale
 Due telecamere a colori con monitor da 5,6', per controllo tamburo argano principale e spazio dietro alla torretta
 Impianto per alimentazione morsa giracolonna
 Argano ausiliario Zollern a discesa libera e controllata - tiro nominale: 70 kN
 Dispositivo controllo verticalità/profondità tipo V2
 Dispositivo controllo automatico verticalità tipo V3
 Pulisci elica stellare
 Pulitore rotante per eliche diametro max. 900 mm
 Vibratore per gabbie
 Apparecchiatura Lutz per la misurazione, la visualizzazione e la registrazione digitale dei seguenti parametri:
 - profondità
 - pressione del calcestruzzo
 - portata e volume del calcestruzzo
 - inclinazione del mast su due assi
 L'apparecchiatura è completa di software per l'elaborazione dei dati su PC
 Dispositivo per la trasmissione tramite telefono cellulare dei parametri di lavoro rilevati dall'apparecchiatura Lutz
 Kit risalita automatica per CFA per apparecchiatura Lutz

Cabin air conditioning/heating system
Low temperature starting kit
Automatic greasing system
Kit of auxiliary lights
High water pressure cleaning pump
Video unit with one camera and 5.6' monitor to control the main winch drum
Video unit with two cameras and one 5.6' monitor to control the main winch drum and the space behind upperstructure
Hydraulic circuit for casing oscillator
Free-controlled fall type auxiliary winch Zollern, - nominal line pull 70 kN
V2 verticality/depth control device
Automatic verticality control device model V3
Star type auger cleaner
Rotating auger cleaner max. diameter 900 mm
Hydraulic vibrator for cages
Lutz instrumentation for measuring, displaying and digital recording of the following parameters:
- drilling depth
- concrete pressure
- concrete capacity and volume
- mast inclination (two axis)
The instrument is complete with software for processing the data on a PC
Device for transmission thru mobile telephon of parameters measured by Lutz instrumentation
Kit for automatic extraction of CFA for Lutz instrumentation



Casagrade S.p.A.

Via A. Malignani, 1 - I-33074 Fontanafredda

Pordenone - Italy

Telephone (+39) 0434 9941 - Fax (+39) 0434 997009

E-mail: info@casagrandegroup.com

casagrade group

www.casagrandegroup.com

Courtesy of Machine.Market