

1150H LT/WT/LGP Crawler Dozer



ENGINE

Model	Case 6T-590 diesel
Cylinders	6
Bore/Stroke	4.02" x 4.72" (102 x 120 mm)
Displacement	359 in ³ (5.9 L)
Fuel injection	Direct
Fuel	#2 Diesel
Fuel filter	Spin-on with in-line strainer
Air intake	Cross-flow
Cooling	Liquid
Engine speeds (rpm)	
High idle - no load	2420±50
Rated - full load	2200
Low idle	800-1050
Horsepower per SAE J1349	
Net	119 (88.7 kW) @ 2000 rpm
Gross	124 (92.5 kW) @ 2000 rpm
Peak torque @ 1600 rpm	
Net	363 lb-ft (492 N·m)
Gross	372 lb-ft (504 N·m)
Engine lubrication -	
Pump	Deep sump plate cooler with pressurized under-piston nozzles
Pump operating angle ratings	
Side-to-side	45°
Fore and aft	45°

ENGINE COOLING

Radiator -	
Core size area	556 in ² (0.36 m ²)
Rows of tubes	6
Fan -	
Diameter	23.6" (600 mm)
Ratio	1.1:1

ELECTRICAL SYSTEM

Alternator	65 amp 95 amp w/ A/C
Battery	12-volt low-maintenance 700 cold-cranking amps @ 0° F (-18 C)

POWERTRAIN

Torque converter	Single-stage
Diameter	13.0" (330 mm)
Stall ratio	2.33
Drawbar pull -	
1st	54,250 lb (241.3 kN)
2nd	36,800 lb (163.9 kN)
3rd	29,700 lb (132.1 kN)
4th	20,023 lb (89.1 kN)
Transmission ...	Case constant-mesh Powershift modulated transmission
Oil filter	10 micron, spin-on replaceable
Gear ratios (fwd/rev) -	
1st	109.5/91.3
2nd	75.1/62.6
3rd	61.0/51.4
4th	41.8/34.8
Travel speeds -	
Forward	mph (km/h)
1st	2.2 (3.5)
2nd	3.2 (5.1)
3rd	3.9 (6.3)
4th	5.8 (9.3)
Reverse	mph (km/h)
1st	2.6 (4.2)
2nd	3.8 (6.2)
3rd	4.6 (7.4)
4th	6.9 (11.1)
Parking brakes	Heavy-duty, spring-applied, hydraulic pressure release
Brakes	Foot-operated, low-effort power
Final drive	Spur and bull gear single reduction

HYDRAULIC SYSTEM

Standard equipment pump	
Pump flow @ 2200 rpm	
@ 2000 psi (138 kPa)	34.9 gpm (132 L/min)

CYLINDERS

Lift cylinder (2)	
Bore diameter	3.25" (83 mm)
Rod diameter	1.75" (44.5 mm)
Stroke	32.19" (818 mm)
Angle cylinder (2)	
Bore diameter	5.0" (127 mm)
Rod diameter	2.5" (64 mm)
Stroke	15.0" (381 mm)
Tilt cylinder (1)	
Bore diameter	5.0" (127 mm)
Rod diameter	2.5" (64 mm)
Stroke	4.72" (120 mm)

UNDERCARRIAGE

Track adjustment	Hydraulic
Frame	Equalizer beam
Length of track on ground ...	97" (2.46 m)
Track link pitch -	
CLT track	6.7" (170 mm)
CELT track	6.9" (175 mm)
Track shoe height	2.06" (52 mm)
Pin diameter	1.44" (37 mm)
Bushing diameter -	
CLT track	2.3" (59 mm)
CELT track	3.1" (79 mm)
Bolt diameter	0.625" (16 mm)
Track shoes per side -	
CLT track	43
CELT track	42
Track rollers per side	7
Carrier rollers per side	2
Track roller rail dia. ...	7.5" (190 mm)

OPERATOR ENVIRONMENT

ROPS canopy
"U" pattern forward/reverse lever
Adjustable armrests
Foot rests
Retractable seat belt, 2" (51 mm)
Vinyl suspension seat
w/back adjustment
Tool storage area

BLADE

Blade pitch..... 60°
Cutting edge Reversible and
replaceable
Width..... 8.0" (203 mm)
Thickness 0.75" (19 mm)

SERVICE CAPACITIES

Fuel tank..... 56 gal (212 L)
Engine oil w/filter 16 qt (15.1 L)
Engine oil w/o filter..... 15 qt (14.3 L)
Engine cooling system 26 qt (24.6 L)
Cooling system –
Cab w/heater..... 29 qt (27.4 L)
Hydraulic reservoir ... 17 gal (64.4 L)
Final drive (per side).... 8.0 qt (7.6 L)
Track rollers (ea.)..... 0.31 qt (0.30 L)
Front idlers (ea.)..... 0.50 qt (0.50 L)
Carrier rollers (ea.).... 0.20 qt (0.20 L)

INSTRUMENTATION

Warning lights:
Air filter
Alternator
Engine oil pressure
Hi range
Hydraulic filter
Transmission filter
Transmission pressure
Gauges:
Battery voltage
Fuel level
Hourmeter
Tachometer
Transmission oil temperature
Water temperature
Audible warnings:
Engine oil pressure
Transmission pressure

RIPPER

Max. penetration..... 19" (483 mm)
Width 66.1" (1679 mm)
Cut width 65.2" (1656 mm)
Ground clearance (at carry) 10"
(254 mm)
Points Replaceable
Max. number of shanks 3
Tooth spacing –
with 3 teeth..... 31" (787 mm)
Hydraulic cylinder (double-acting)
Diameter 4" (102 mm)
Stroke 10" (254 mm)
Rod 2" (51 mm)

OPERATING WEIGHTS

Unit equipped with ROPS, full fuel
tank, 170 lb (77 kg) operator, draw-
bar, side shield, track guides, backup
alarm, horn and lights.
Long Track..... 25,300 lb (11 474 kg)
Wide Track.....26,400 lb (11 975 kg)
LGP 27,060 lb (12 274 kg)
Add-on weights –
Drawbar..... 220 lb (100 kg)
Ripper (3 shank)... 2,250 lb (1021 kg)
Winch 1,550 lb (703 kg)
Front counterweight... 1,090 lb (493 kg)
Cab 785 lb (356 kg)
Air conditioning..... 160 lb (73 kg)
ROPS heater..... 70 lb (32 kg)
CELT chain..... 375 lb (170 kg)

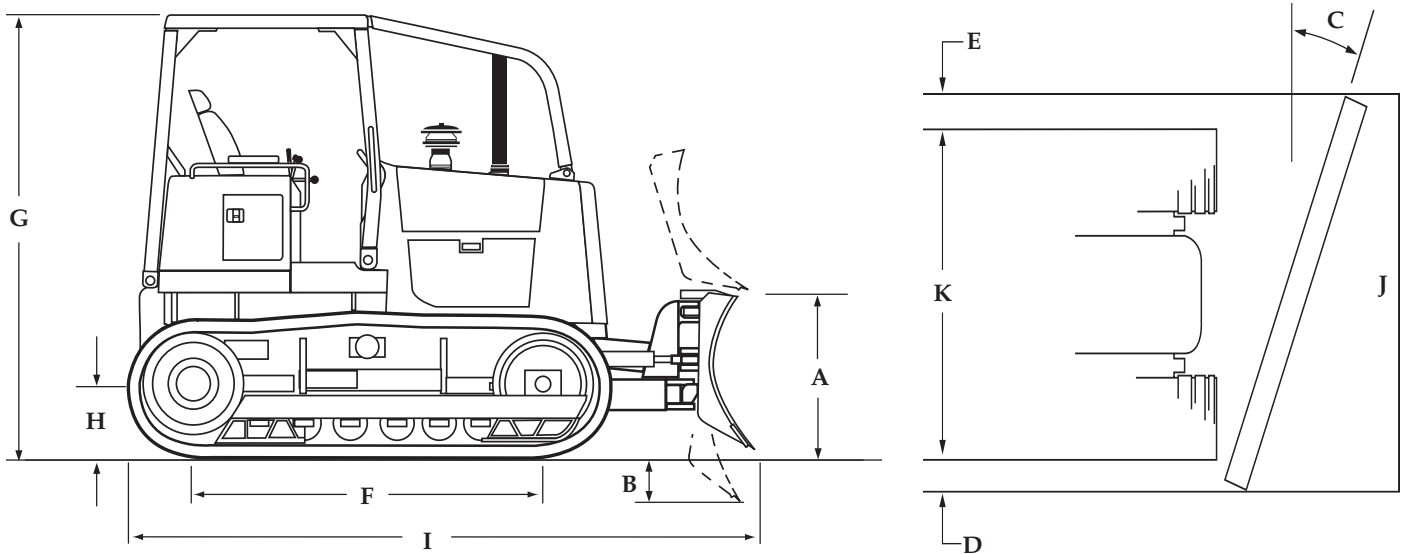

DIMENSIONS

	Long Track (LT)	Wide Track (WT)	Low Ground Pressure (LGP)
BLADES			
Blade width	110" (2.79 m)	124" (3.15 m)	124" (3.15 m)
SAE blade capacity	3.4 yd ³ (2.60 m ³)	3.9 yd ³ (2.98 m ³)	3.9 yd ³ (2.98 m ³)
A. Blade lift above ground	38" (965 mm)	38" (965 mm)	38" (965 mm)
B. Blade depth below ground	19" (483 mm)	19" (483 mm)	19" (483 mm)
C. Blade angle both directions	25°	25°	17°
Blade tilt, each end (up to 8.3°)	13.6" (345 mm)	15" (381 mm)	15" (381 mm)
Blade height	44" (1118 mm)	44" (1118 mm)	44" (1118 mm)
D. Cast reach	15.1" (384 mm)	15.5" (394 mm)	9.5" (241 mm)
E. Cut reach	0.6" (15 mm)	1.0" (25 mm)	-5.0" (-127 mm)
TRACKS			
Track gauge	62" (1.57 m)	74" (1.88 m)	74" (1.88 m)
Shoe width	22" (559 mm)	28" (711 mm)	34" (864 mm)
F. Track on ground	97" (2.46 m)	97" (2.46 m)	97" (2.46 m)
Area of track on ground	4255 in ² (2.75 m ²)	5415 in ² (3.49 m ²)	6575 in ² (4.24 m ²)
Ground pressure	6.0 psi (41.0 kPa)	4.9 psi (33.6 kPa)	4.1 psi (28.9 kPa)
DIMENSIONS			
G. Height to top of ROPS	9'5.7" (2.89 m)	9'5.7" (2.89 m)	9'5.7" (2.89 m)
Height to top of cab	9'10.8" (3.02 m)	9'10.8" (3.02 m)	9'10.8" (3.02 m)
with air conditioning	10'5" (3.17 m)	10'5" (3.17 m)	10'5" (3.17 m)
H. Ground clearance w/drawbar	12.9" (328 mm)	12.9" (328 mm)	12.9" (328 mm)
Turning clearance circle, pivot turn	24'7" (7.5 m)	26'8" (8.1 m)	26'8" (8.1 m)
Length –			
I. Blade straight with drawbar	16'1.5" (4.91 m)	16'1.5" (4.91 m)	16'1.5" (4.91 m)
Blade straight with ripper	16'5" (5.00 m)	16'5" (5.00 m)	16'5" (5.00 m)
Width –			
J. Blade straight	9'2" (2.80 m)	10'4" (3.15 m)	10'4" (3.15 m)
Blade angled	8'6" (2.59 m)	9'7" (2.92 m)	9'11" (3.02 m)
K. Over track	84" (2.13 m)	96" (2.44 m)	108" (2.74 m)

STANDARD EQUIPMENT

OPERATOR'S COMPARTMENT

ROPS/FOPS canopy
Vinyl suspension seat w/back adjustment
Retractable seat belt, 2" (51 mm)
Adjustable armrests
Foot rests
Tool storage area

ENGINE

Case 6T-590 diesel
Automatic fan belt tensioner
Integral engine oil cooling
Fuel filter
Dual element radial seal air cleaner
65 amp alternator
700 CCA 12-volt battery
Anti-sandblast radiator
Engine side panels

POWERTRAIN

4F/4R modulated Powershift transmission
Automatic spring-applied parking brake
Oil-cooled power disc brakes

BLADE

Single lever control for blade lift, angle and tilt

UNDERCARRIAGE

Hydraulic track adjusters
Case Lubricated Track Chain
Permanently lubricated track and carrier rollers
Track adjuster guard
Track guides (front and rear)

OTHER

Backup alarm
Horn
Anti-vandalism package
Mirror
Pre-cleaner
Lights - 2 front, 2 rear
Rear transmission guard
Heavy-duty bottom transmission guard

OPTIONAL EQUIPMENT

OPERATOR'S COMPARTMENT

Cab (w/heater, defroster, front windshield washer and lights)
Air conditioner (cab units only)
ROPS heater
3" (76 mm) seat belt
Deluxe air suspension seat
Decelerator
In-line shift pattern
ROPS headliner

HYDRAULICS

4 spool hydraulic valve for field-installed ripper

REAR MOUNTED EQUIPMENT

Ripper, 3 slot with 3 shanks

BLADES

110" (2.79 m) LT
124" (3.15 m) WT w/22" (559 mm) shoes
124" (3.15 m) WT w/28" (711 mm) shoes
124" (3.15 m) LGP w/34" (864 mm) shoes

GUARDS

Sweeps
Center rockguard
Final drive bottom
Final drive seal

SCREENS

Rear ROPS and cab
Side ROPS
Radiator brush

OTHER

Counterweight, front
Drawbar
Special paint
Dual 12V battery
Front pull hook
Fan, reversible
Case Extended Life Track
Leg cushion pads
Cold start aid

TRACK

LONG TRACK

20" (508 mm) closed grousers and CLT
20" (508 mm) open grousers and CELT
22" (559 mm) closed grousers and CLT
22" (559 mm) open grousers and CELT

WIDE TRACK

22" (559 mm) closed grousers and CLT
22" (559 mm) open grousers and CELT
28" (711 mm) closed grousers and CLT
28" (711 mm) open grousers and CELT

LGP

34" (864 mm) closed grousers and CLT
34" (864 mm) open grousers and CELT

NOTE: All specifications are stated in accordance with SAE Standards or Recommended Practices, where applicable.

Form No. CE 242-12-99

Replaces Form No. - None

IMPORTANT: Case Corporation reserves the right to change these specifications without notice and without incurring any obligation relating to such change. Case Corporation does not warrant the safety or reliability of attachments from other manufacturers.

Visit Case Corporation on the Web at:

<http://www.casecorp.com>

Printed in U.S.A.

© 1999 CASE CORPORATION

All Rights Reserved. Case is a registered trademark of Case Corporation.

CASE CORPORATION

700 STATE STREET
RACINE, WI 53404 U.S.A.

CASE CANADA CORPORATION

3350 SOUTH SERVICE ROAD
BURLINGTON, ON L7N 3M6 CANADA

