

CASE
CONSTRUCTION

2050M
CRAWLER DOZER



2050M Crawler Dozer

24 TONS* OF MORE.

More strength. More efficiency. More command. The CASE 2050M has been engineered with more in mind. It pushes the limits on power and drawbar pull, gives operators greater control and comes with the most product support

available in the industry. But this mammoth is also about efficiency; less time spent on maintenance, less fuel usage, less downtime. Simply put, from fine grading to heavy dozing, the 2050M gets more done.



*24 tons represents 2050M LGP with bulldozer blade

2050M Highlights

- 1 Massive drawbar pull** provides constant power to keep pushing under extreme loads.
- 2 Advanced SCR engine technology** provides a **14% power increase** and a **10.5% fuel savings** over previous generations and greater uptime over competitive solutions.
- 3 New cab-forward design, floor-to-ceiling glass doors and sloped hood provide maximum visibility to the blade and ground.**
- 4 Track covers have been angled to 49 degrees for improved self-cleaning** in deep mud applications.
- 5 Positive-pressure cab** with advanced sealing and an isolated design keep out dust and noise to provide one of the industry's quietest operating environments.
- 6 Robust, box-style C-frame** is engineered to withstand the industry's strongest drawbar pull.
- 7 New V-shaped cooling package** incorporates a hydraulic, variable speed fan with reversible functionality to keep radiators clean and maintain optimal working temperatures.
- 8 Three-bolt, removable floor panel in the cab** provides clean, quick access to hydraulic components.
- 9 Enhanced fingertip blade controls** such as blade angle, blade sensitivity, blade shake for quick cleaning, automatic blade control and fine grading on command, which reduces blade speed by 40% for increased accuracy.
- 10 All daily checkpoints are accessible from ground level** and don't require the use of hand tools.
- 11 Larger heavy-duty cylinders with improved seals** designed to deliver outstanding blade force.
- 12 Adjustable steering and shuttle ratio settings** (Smooth, Moderate or Aggressive) to help match ground conditions and operator preference.
- 13 Optional factory-installed radio** enhances operating environment.

An exclusive solution.

CASE M Series are the only dozers powered exclusively by fuel-efficient SCR technology – the Tier 4 Interim solution proven to maximize power, minimize fuel use and reduce maintenance costs.



Precise controls. Productive comfort.

The 2050M puts finesse at your fingertips to control the force up front. A new, electro-hydraulic joystick and upgraded dashboard and new control setup ensures blade control or machine movement can be performed with minimal effort. And because the best operator is a comfortable one, the M Series offers an all-new pressurized cab design that gives greater visibility, keeps out more dust, seals out more sound and provides a better balance for a smoother ride.



Serviceability is in our DNA.

Like all CASE equipment, the M Series is built to minimize maintenance time. Heavy-duty panels with pressure-closing latches are housed on a solid, one-piece frame that's designed to give quick access to key service points. Now daily maintenance can be done in a matter of minutes.



www.CaseCE.com

2050M XLT

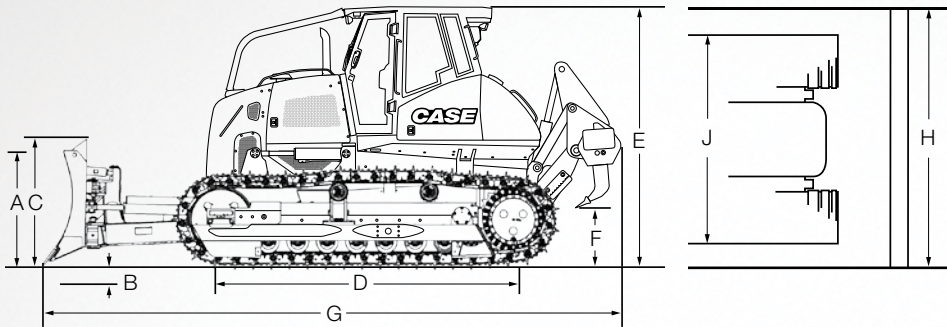

Line drawings are for illustrative purpose only and may not be exact representation of unit.

DIMENSIONS	2050M XLT PAT Blade
A. Blade Lift Above Ground	44.5 in. (1 130 mm)
B. Blade Depth Below Ground	21.2 in. (539 mm)
C. Blade Height	51.6 in. (1 310 mm)
D. Length Of Track On Ground	129.0 in. (3 277 mm)
E. Height To Top Of Cab	10 ft. 2 in. (3 103 mm)
F. Ground Clearance	20.7 in. (525 mm)
G. Length, Blade Straight With Ripper	24 ft. 3 in. (7 384 mm)
H. Width, Blade Straight	11 ft. 10 in. (3 607 mm)
J. Width, Over Track	8 ft. 4 in. (2 550 mm)

SPECIFICATIONS	2050M XLT
Engine	Case F4HFE613W
Engine Cylinders	6
Displacement – in. ³ (L)	409 (6.7)
Net hp (kW) @ 2000 RPM	214 (160)
Emissions Rating	Tier 4 Interim Certified
Operating Weight* – lb. (kg)	45,414 (20 599)
Blade Width* – in. (mm)	142 (3 607)
Blade Capacity – yd ³ (m ³)	6.3 (4.8)
Maximum Drawbar Pull** – lb. (kN)	80,979 (360)

Note: *Various blade options available for each track configuration.

**Measured using standard track chain. Increase travel speeds by 4% and reduce drawbar pull by 4% with the optional CELT track chain.

Protected by

ProCare

The 2050M comes standard with the industry's first all-in-one heavy machine support program that's as powerful as the equipment it protects – CASE ProCare. ProCare includes:

3K 3-year/3000-hr.
Full-Machine Factory Warranty*.

We've got your back – for up to three full years!

3-year/3000-hr.
Planned Maintenance.

Don't spend another dime for scheduled care from factory-trained CASE technicians.

3-year SiteWatch™
Subscription.

Telematics isn't a luxury, it's a necessity – and we've made it accessible to all.



Scan to learn more
or visit CaseCE.com/procare.

*See your dealer for the complete terms of CNH's Warranty and Limitation of Liability, which contains certain limits and exclusions.



©2013 CNH America LLC. All rights reserved. CASE is a registered trademark of CNH America LLC. Any trademarks referred to herein, in association with goods and/or services of companies other than CNH America LLC, are the property of those respective companies. Printed in U.S.A.

Form No. CCE2013102050MPreBro



SAFETY™
NEVER HURTS

Always read the operator's manual before operating any equipment. Inspect equipment before using it, and be sure it is operating properly. Follow the product safety signs and use any safety features provided.

All engines meet current EPA emission regulations.

All specifications are stated in accordance with SAE standards or recommended practices, where applicable.



Contains 10%
post-consumer fiber

IMPORTANT: CASE Construction Equipment Inc. reserves the right to change these specifications without notice and without incurring any obligation relating to such change. Availability of some models and equipment builds vary according to the country in which the equipment is used. The illustrations and text may include optional equipment and accessories and may not include all standard equipment. Your CASE dealer/distributor will be able to give you details of the products and their specifications available in your area.



CASE construction equipment
is biodiesel friendly.

Courtesy of MachineMarket