

580 Super L Series 2 Loader/Backhoe



ENGINE

Model Case 4T-390 diesel
 Type..... 4-stroke, turbocharged
 Cylinders 4
 Bore/Stroke 4.02" x 4.72"
 (102 X 120 mm)
 Displacement 239 in³ (3.9 L)
 Fuel injection..... Direct
 Fuel..... Diesel
 Fuel filter In-line strainer
 Air intake Cross-flow
 Cooling Liquid
 Engine speeds* (rpm)
 Rated speed, full load 2200
 Low idle 900 - 1100
 High idle, no load 2378 - 2471
 Horsepower
 Gross 95 (71 kW) @ 2200 rpm
 Net 90 (67 kW) @ 2200 rpm
 Maximum torque @ 1500 rpm
 Gross 283 lb-ft (384 N·m)
 Net 279 lb-ft (378 N·m)
 Torque rise at rated speed 24%

NOTE: *Engine speeds with standard transmission. Meets federal emission regulations.

ENGINE COOLING

Radiator (Non Air-Conditioned)
 Core type..... Square wave
 Core size area 369 in² (.238 m²)
 Rows of tubes..... 5
 Fan w/standard transmission
 Style 7 blade suction
 Diameter 19.2" (488 mm)
 Ratio 1.1:1
 Water pump
 Style Integral
 Engine oil
 Pump..... Deep sump plate cooler
 with pressurized
 under-piston nozzles
 Pump operating angle ratings
 Side-to-side Rated 45°
 Fore and aft..... Rated 45°
 Oil filtration..... Replaceable,
 full-flow cartridge

POWERTRAIN

Transmission... 4-speed synchromesh
 with hydraulically actuated
 clutches and electric
 F/R shuttle control, clutch
 disconnect buttons on the
 transmission shifter and
 loader control lever
 Gear ratios Forward Reverse
 1st..... 5.491 4.550
 2nd 3.043 2.522
 3rd 1.584 1.313
 4th 0.793 0.657
 Torque converter
 Ratio 2.63
 Differential-lock On-the-go
 push-button activation
 Front 4WD axle
 Differential ratio 2.0
 Planetary hub ratio 6.0
 Total reduction ratio..... 12.0
 Rear axle
 Differential ratio 2.333
 Planetary hub ratio 6.923
 Total reduction ratio..... 16.153
 Service brakes .. Individually applied
 hydraulically actuated
 maintenance-free self-adjusting
 inboard mounted wet disc
 Disc area..... 53 in² (.03 m²)
 Parking brakes Mechanically
 applied with electric activation
 sensors at each brake
 Travel speeds – mph (km/h)
 1st 2nd 3rd 4th
 Forward 3.6 6.6 12.6 25.1
 (5.8) (10.5) (20.2) (40.4)
 Reverse 4.4 7.9 15.2 30.3
 (7.1) (12.7) (24.4) (48.8)

NOTE: Travel speeds at 2348 engine rpm with 19.5L x 24 rear tires. Speeds decrease with 17.5L x 24 rear tires.

TIRES

Front
 2WD – 11L x 16.1, 10-ply rating
 4WD – 12 x 16.5, 8-ply rating
 Rear
 2/4WD – 17.5L x 24, 10-ply rating
 2/4WD – 19.5L x 24, 10-ply rating

HYDRAULICS

Pump Gear-type tandem,
 front mounted, direct drive
 to engine crankshaft
 Loader flow @ rated engine rpm
 28.5 gpm @ 3000 psi
 (108 L/min @ 207 bar)
 Loader control valve..... Sectional
 2 or 3-spool with
 single lever control for
 lift, tilt and auxiliary hydraulics,
 positive hold float
 and return-to-dig
 Backhoe flow @ rated engine rpm
 38 gpm @ 3000 psi
 (144 L/min @ 207 bar)
 Backhoe control valve Sectional
 6, 7 or 8-spool, open-center
 parallel circuits with regeneration
 for boom, dipperstick, bucket,
 swing, two stabilizers, Extendahoe®
 dipperstick and auxiliary
 Loader auxiliary hydraulics
 13 to 28.5 gpm
 (49 to 108 L/min)
 Backhoe auxiliary hydraulics
 Uni- and bi-directional flow,
 directional lever with
 foot pedal activation
 Low-flow 17 to 28 gpm
 (64 to 106 L/min)
 High-flow 26 to 38 gpm
 (98 to 144 L/min)
 Hand-held auxiliary hydraulics
 8 to 17 gpm
 (30 to 64 L/min)
 Main relief pressure
 3050 + 50 - 50 psi @ 14 gpm
 (210 + 3 - 3 bar @ 53 L/min)
 Filtration 7-micron,
 full flow replaceable
 cartridge on return line, condition
 indicator light for filter
 Oil cooler..... Heavy-duty

ELECTRICAL

Voltage..... 12 Volts, negative ground
 Alternator..... 65 amp (2.5 kW)
 Battery 685 cold-cranking amps
 Optional batteries..... (2) 525
 cold-cranking amps

OPERATOR ENVIRONMENT

ROPS/FOPS canopy
Key start
Hydrostatic steering
Standard seat w/180° swivel
Hand and foot throttles
Loader control lever w/push-button activation of differential lock and transmission de-clutch
Backhoe foot-swing w/3 lever control
(2) Accessory power plugs (30 amp)
Anti-vandalism covers (canopy only)
Beverage holder
Coat hook w/tether strap
Interior rear-view mirror
2" (51 mm) retractable seat belt
Storage box

INSTRUMENTATION

Gauges
Engine water temperature
Converter oil temperature
Fuel
Tachometer/hourmeter
Voltmeter
Warning lights
Air cleaner restriction
Alternator
Engine oil pressure
Hydraulic oil filter bypass
Parking brake engagement
Rear axle fluid temperature sensing system
Audible alarms
Coolant temperature
Engine oil pressure
Parking brake engagement
Shuttle engagement/seat position
Backup alarm
Turn signal indicators
Horn

TURNING DIAMETER

2WD
Brakes on..... 21'3" (6.48 m)
Brakes off..... 24'8" (7.52 m)
4WD – engaged
Brakes on..... 22'1" (6.72 m)
Brakes off..... 28'3" (8.62 m)
4WD – disengaged
Brakes on..... 22'0" (6.70 m)
Brakes off..... 25'3" (7.70 m)

NOTE: Turning diameter dimensions curb to curb w/19.5L x 24 tires and 82" (2.08 m) general purpose bucket.

OPERATING WEIGHTS

Lightest Configuration
Unit equipped with 2WD,
ROPS/FOPS canopy, non-suspension seat, 82" (2.08 m) general purpose loader bucket, 24" (610 mm) Universal H.D. backhoe bucket, standard dipperstick, 17.5L x 24 rear tires, 11L x 16.1 front tires, single battery, standard cast stabilizer pads, no operator 13,306 lb (6036 kg)

Heaviest Configuration
Unit equipped with 4WD, cab, suspension seat, 82" (2.08 m) 4 IN 1® loader bucket, 24" (610 mm) Universal H.D. backhoe bucket, Extendahoe® dipperstick, 19.5L x 24 rear tires, 12L x 16.5 front tires, dual batteries, flip stabilizer pads, no operator 15,761 lb (7149 kg)

Add-on weights

Cab (over canopy) ... +454 lb (206 kg)
Counterweights..... +440 lb (200 kg) +900 lb (408 kg)
Extendahoe® +496 lb (225 kg)
4WD w/driveshaft guard..... + 283 lb (128 kg)

SERVICE CAPACITIES

Fuel tank 31.4 gal (119 L)
Optional tank 40.0 gal (151 L)
Hydraulic system
Total 31.5 gal (119 L)
Total w/Extendahoe® 33.0 gal (125 L)
Reservoir w/filter .. 14.5 gal (54.9 L)
Reservoir w/o filter . 14.0 gal (53 L)
Transmission
2WD Total system .. 19.5 qt (18.5 L)
4WD Total system .. 22.0 qt (20.8 L)
4WD Front axle
Differential..... 5.8 qt (5.5 L)
Planetaries (each)..... 0.7 qt (0.66 L)
Rear axle
Differential..... 15.0 qt (14.2 L)
Planetaries (each)..... 1.6 qt (1.5 L)
Engine oil w/filter 11.6 qt (10.97 L)
Cooling system
w/heater 17.4 qt (16.5 L)
w/o heater..... 16.7 qt (15.8 L)
Window washer reservoir..... 2.5 qt (2.36 L)

LOADER

Single-lever control for lift and tilt
Positive hold float
Return-to-dig
Automatic self-leveling
In-line, reverse linkage
Dual parallel dump cylinders
Clutch disconnect button on loader control and shift levers
Bucket position indicator

Loader Bucket Sizes

Width	Weight	Struck	Heaped
General Purpose Bucket			
82" (2.08 m)	686 lb* (311 kg)	0.87 yd ³ (0.67 m ³)	1.03 yd ³ (0.79 m ³)
93" (2.36 m)	1,123 lb (509 kg)	1.1 yd ³ (0.84 m ³)	1.3 yd ³ (1.0 m ³)
4 IN 1® Bucket			
82" (2.08 m)	1462 lb (663 kg)	0.85 yd ³ (0.65 m ³)	1.04 yd ³ (0.80 m ³)

NOTE: *Add 103 lb (47 kg) to 82" (2.08 m) general purpose bucket for bolt-on cutting edge.

BACKHOE

Over-center design
Cast, ductile iron boom, dipperstick and swing tower w/5 year warranty
Open-center hydraulics
194,200 lb-in (21 940 N-m) swing torque
Case attachment coupler
Foot-swing w/3 lever control
Wing-style stabilizers w/cleated dirt pad

Backhoe Bucket Sizes

Universal H.D. Trenching Buckets			
Width	Weight	Heaped	
12" (305 mm)	311 lb (141 kg)	2.90 ft ³ (0.08 m ³)	
16" (406 mm)	346 lb (157 kg)	3.60 ft ³ (0.10 m ³)	
18" (457 mm)	359 lb (163 kg)	4.30 ft ³ (0.12 m ³)	
24" (610 mm)	429 lb (195 kg)	6.40 ft ³ (0.18 m ³)	
30" (762 mm)	496 lb (225 kg)	8.65 ft ³ (0.24 m ³)	
36" (914 mm)	571 lb (259 kg)	10.80 ft ³ (0.30 m ³)	

High Capacity Buckets

Width	Weight	Heaped	
24" (610 mm)	430 lb (195 kg)	8.50 ft ³ (0.24 m ³)	
30" (762 mm)	447 lb (203 kg)	10.60 ft ³ (0.3 m ³)	

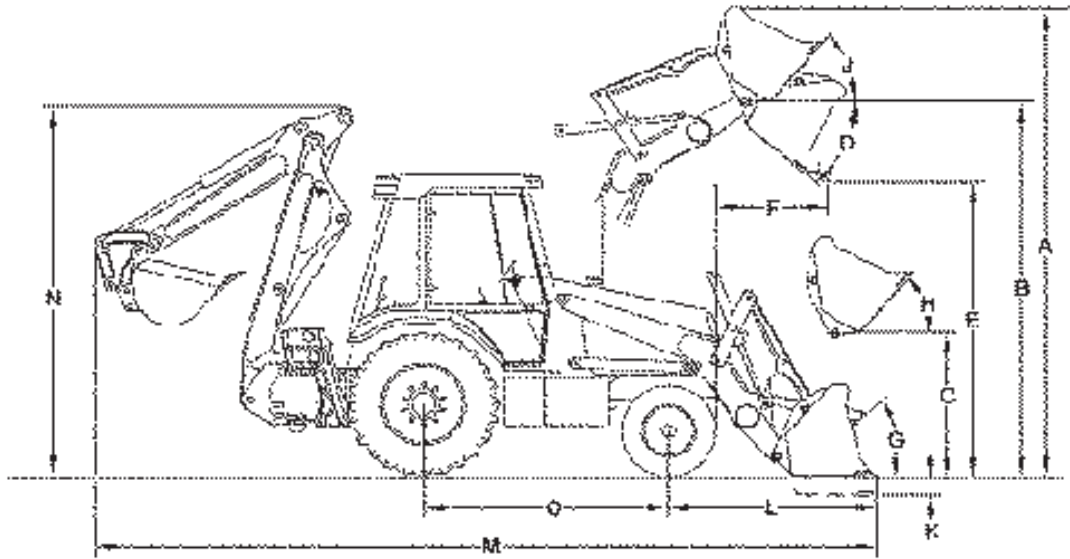

LOADER DIMENSIONS

	General Purpose Bucket*	4 IN 1® Bucket
A. Overall operating height – fully raised	13'11" (4.25 m)	14'3" (4.34 m)
Height to –		
B. Bucket hinge pin fully raised	11'2" (3.4 m)	11'2" (3.4 m)
C. Bucket hinge pin @ SAE carry	13.1" (334 mm)	14.6" (372 mm)
D. Dump angle @ full height	45°	45°
E. Dump clearance @ full height, 45° dump –		
Bucket	8'10" (2.69 m)	8'11" (2.72 m)
Clam open	NA	9'8" (2.95 m)
F. Dump reach @ full height, 45° dump –		
Bucket	27.7" (703 mm)	25.5" (647 mm)
Clam open	NA	11.9" (302 mm)
Bucket rollback –		
G. @ groundline	40°	40°
H. @ SAE carry	45°	45°
J. @ full height	Adjustable	Adjustable
K. Digging depth below grade –		
Bucket flat	5.9" (149 mm)	6.8" (180 mm)
Clam open (dozing)	NA	4.1" (103 mm)
L. Reach from front axle centerline – bucket on ground	75.2" (1.91 m)	72.7" (1.85 m)
Lift capacity to full height	6,182 lb (2804 kg)	5,514 lb (2501 kg)
Breakout force –		
Lift cylinders	9,453 lbf (42 049 N)	8,859 lbf (39 407 N)
Dump cylinders	9,667 lbf (43 000 N)	10,294 lbf (45 790 N)
Bucket cutting edge width	82" (2.08 m)	82" (2.08 m)
Maximum grading angle	116°	116°
Maximum clam opening	NA	38.3" (972 mm)
Moldboard height	NA	36.8" (934 mm)
Raising time to full height	5.34 sec	5.34 sec
Bucket dumping time	1.06 sec	1.06 sec
Lowering time –		
Power down	2.44 sec	2.44 sec
Return-to-dig	3.17 sec	3.17 sec
Clam –		
Open time	NA	2.28 sec
Close time	NA	3.13 sec

NOTE: Loader dimensions taken with 4WD,
19.5L x 24 rear tires and 82" (2.08 m) general
purpose bucket *without bolt-on cutting edge.

DIMENSIONS

	Extendahoe®		
	Standard Backhoe	Retracted	Extended
M. Overall transport length –			
General purpose bucket.....	22'7" (6.89 m)	22'7" (6.89 m)	NA
4 IN 1® bucket.....	22'4" (6.82 m)	22'6" (6.86 m)	NA
Overall transport width.....	7'2" (2.18 m)	7'2" (2.18 m)	NA
Height –			
To top of canopy.....	8'9" (2.67 m)	8'9" (2.67 m)	8'9" (2.67 m)
To top of cab.....	8'10" (2.69 m)	8'10" (2.69 m)	8'10" (2.69 m)
To top of exhaust stack.....	8'6" (2.59 m)	8'6" (2.59 m)	8'6" (2.59 m)
N. Transport.....	10'10" (3.29 m)	11'3" (3.42 m)	NA
Ground clearance at backhoe frame.....	14.6" (371 mm)	14.6" (371 mm)	14.6" (371 mm)
Angle of departure.....	20°	20°	20°
Front wheel tread –			
2WD.....	67.5" (1.71 m)	67.5" (1.71 m)	NA
4WD.....	67.7" (1.72 m)	67.7" (1.72 m)	NA
Rear wheel tread.....	61.2" (1.55 m)	61.2" (1.55 m)	NA
O. Wheelbase –			
2WD.....	84" (2.13 m)	84" (2.13 m)	NA
4WD.....	84.5" (2.15 m)	84.5" (2.15 m)	NA

NOTE: Dimensions taken with 19.5L x 24 rear tires and 11L x 16 front tires except that data marked 4WD is taken with 12 x 16.5 front tires.

CYLINDERS

	Bore Diameter	Rod Diameter	Stroke
Loader			
Lift (2).....	3.25" (83 mm)	1.75" (44.5 mm)	30.2" (766 mm)
Bucket (2).....	3.0" (76 mm)	1.5" (38.1 mm)	20.6" (522 mm)
4 IN 1® clam (2).....	3.0" (76 mm)	1.75" (44.5 mm)	9.1" (231 mm)
Backhoe			
Boom.....	5.0" (127 mm)	2.25" (57.2 mm)	33.2" (842 mm)
Dipperstick.....	5.0" (127 mm)	2.5" (63 mm)	22.9" (583 mm)
Bucket.....	3.5" (89 mm)	2.5" (63 mm)	34.3" (872 mm)
Extendahoe®.....	3.0" (76 mm)	1.75" (44.5 mm)	42.0" (1.07 m)
Swing (2).....	4.0" (101.6 mm)	2.0" (50.8 mm)	11.5" (292 mm)
Stabilizer (2).....	4.25" (108 mm)	2.0" (50.8 mm)	21.8" (553 mm)
Steering			
2WD.....	2.75" (69.9 mm)	1.5" (38.1 mm)	6.7" (170 mm)
4WD.....	2.48" (63 mm)	1.496" (38 mm)	9.53" (242 mm)

BACKHOE LIFT CAPACITIES

Boom Lift	Extendahoe®		
	Standard Backhoe	Retracted	Extended
+16' (4.87 m)			1,140 lb (517 kg)
+14' (4.27 m)	2,240 lb (1016 kg)	1,840 lb (835 kg)	1,450 lb (658 kg)
+12' (3.66 m)	2,680 lb (1216 kg)	2,220 lb (1007 kg)	1,580 lb (717 kg)
+10' (3.05 m)	2,750 lb (1247 kg)	2,400 lb (1089 kg)	1,660 lb (753 kg)
+8' (2.44 m)	2,710 lb (1229 kg)	2,410 lb (1093 kg)	1,690 lb (767 kg)
+6' (1.83 m)	2,680 lb (1216 kg)	2,390 lb (1084 kg)	1,700 lb (771 kg)
+4' (1.22 m)	2,630 lb (1193 kg)	2,370 lb (1075 kg)	1,700 lb (771 kg)
+2' (0.61 m)	2,560 lb (1161 kg)	2,330 lb (1057 kg)	1,700 lb (771 kg)
Ground Level	2,550 lb (1157 kg)	2,270 lb (1030 kg)	1,690 lb (767 kg)
-2' (0.61 m)	2,460 lb (1116 kg)	2,230 lb (1011 kg)	1,650 lb (748 kg)
-4' (1.22 m)	2,380 lb (1079 kg)	2,140 lb (971 kg)	1,640 lb (744 kg)
-6' (1.83 m)	2,380 lb (1079 kg)	2,150 lb (975 kg)	1,640 lb (744 kg)
-8' (2.44 m)	2,380 lb (1079 kg)	2,150 lb (975 kg)	1,640 lb (744 kg)
-10' (3.05 m)	2,590 lb (1175 kg)	2,260 lb (1025 kg)	1,700 lb (771 kg)
-12' (3.66 m)			1,860 lb (844 kg)
-14' (4.27 m)			2,260 lb (1025 kg)
Dipper Lift			
+14' (4.27 m)			2,580 lb (1170 kg)
+12' (3.66 m)	4,940 lb (2241 kg)	4,360 lb (1978 kg)	2,680 lb (1216 kg)
+10' (3.05 m)	4,650 lb (2109 kg)	4,190 lb (1901 kg)	2,700 lb (1225 kg)
+8' (2.44 m)	4,680 lb (2123 kg)	4,160 lb (1887 kg)	2,880 lb (1306 kg)
+6' (1.83 m)	5,290 lb (2400 kg)	4,680 lb (2123 kg)	2,910 lb (1320 kg)
+4' (1.22 m)	6,610 lb (2998 kg)	5,590 lb (2536 kg)	3,050 lb (1383 kg)

BACKHOE OPERATIONAL DATA

	Extendahoe®		
	Standard Backhoe	Retracted	Extended
Digging depth –			
Maximum	14'5" (4.39 m)	14'10" (4.52 m)	18'3" (5.56 m)
Maximum w/hi-capacity bucket	14'10" (4.52 m)	15'3" (4.65 m)	18'8" (5.69 m)
2' (610 mm) flat bottom	14'3" (4.34 m)	14'8" (4.47 m)	18'2" (5.54 m)
8' (2.44 m) flat bottom	13'4" (4.06 m)	13'9" (4.19 m)	17'6" (5.33 m)
Overall reach from –			
Rear axle centerline	21'5" (6.53 m)	22'0" (6.70 m)	25'5" (7.75 m)
Swing pivot	18'1" (5.51 m)	18'5" (5.61 m)	21'10" (6.65 m)
Loading height	11'2" (3.40 m)	11'5" (3.48 m)	13'3" (4.04 m)
Loading reach – dipper retracted	8'9" (2.67 m)	8'8" (2.64 m)	11'6" (3.50 m)
Swing arc	180°	180°	180°
Bucket rotation –			
#1 position	164°	164°	164°
#2 position	200°	190°	190°
Stabilizer spread – operating	9'5" (2.87 m)	9'5" (2.87 m)	9'5" (2.87 m)
Digging force –			
Bucket cylinder	12,821 lbf (57 031 N)	12,821 lbf (57 031 N)	12,821 lbf (57 031 N)
Dipper cylinder	8,224 lbf (36 582 N)	7,784 lbf (25 066 N)	5,635 lbf (25 066 N)
	w/bucket @ 50°	w/bucket @ 50°	w/bucket @ 51°
Leveling angle			
maximum slope that backhoe will make vertical cut	12°	12°	12°

NOTE: Lift capacities apply straight to the rear of prime mover. Equipped with 24" (610 mm) Universal H.D. trenching bucket, Case coupler and link except as noted.

STANDARD EQUIPMENT

OPERATOR'S COMPARTMENT

See page 2

ENGINE

Case 4T-390 turbocharged diesel
Automatic fan belt tensioner
Integral engine oil cooling
Fuel filter w/water trap
Air intake pre-cleaner
Dual element air cleaner
65 amp alternator
685 CCA 12-volt battery
Heavy-duty radiator
Non-spark-arresting muffler

LOADER

See page 2

BACKHOE

See page 2

POWERTRAIN

2WD
4F/4R Power shuttle synchromesh transmission
Torque converter
Transmission de-clutch
Electro-hydraulic differential lock
Hydrostatic steering
Wet disc brakes

HYDRAULICS

2-spool loader control valve
6-spool backhoe control valve
Heavy-duty oil cooler

OTHER

Forward tilt engine hood
Replaceable, molded front bumpers
Lights
2 Halogen headlights
2 Front Flood
4 Rear flood
2 Rear tail and stop
2 Front flashers/turn
2 Rear flashers/turn

OPTIONAL EQUIPMENT

OPERATOR'S COMPARTMENT

Ride Control
Cab with –
Defroster
Dome light
Wipers, front and rear
Tinted glass
Floor mat
Air-suspension seat (cab unit only)
Vinyl or cloth covered mechanical suspension seat
Cab Convenience Package with –
Vinyl-covered cloth interior
Radio-ready kit w/antenna and speakers
Reduced sound level to 75 dB(A)
Window washers w/adjustable spray nozzles front and rear
Additional storage tray behind RH console
Sunvisor
Sunvisor for canopy models
3" (75 mm) retractable seat belt
Cab heater
Cab air-conditioning w/heater

ENGINE

Cold weather ether starting aid
Alternator, 95 amp
Dual, 12-volt, 525 CCA batteries
Chaff screen
Fuel tank, 40 gal (151 L)

LOADER

Hydraulic attachment coupler
Attachment auxiliary hydraulics
Buckets (see page 2)

BACKHOE

Attachment auxiliary hydraulics
Buckets (see page 2)
Extendahoe®
Two-lever control
Stabilizer pads
Flip-over
Rubber pad
Front counterweights
440 lb (200 kg)
900 lb (408 kg)

POWERTRAIN

4WD w/outboard planetary drive, on-the-go push-button activation and 12 x 16.5 front tires
Powershift transmission (4WD unit only)

HYDRAULICS

Auxiliary hydraulics for hand-held equipment

OTHER

17.5L x 24 rear tires
19.5L x 24 rear tires
Tool box
Special paint
Lights
2 Front flood
2 Rear flood

NOTE: All specifications are stated in accordance with SAE Standards or Recommended Practices, where applicable.

Form No. CE 166-11-97
Replaces Form No. - None

Case is a registered trademark of Case Corporation.



IMPORTANT: Case Corporation reserves the right to change these specifications without notice and without incurring any obligation relating to such change. Units shown may be equipped with non-standard equipment. Attachments from other manufacturers are shown for illustration only. Case Corporation does not warrant the safety or reliability of attachments from other manufacturers.

Visit Case Corporation on the Web at:
<http://www.casecorp.com>
Printed in U.S.A.

580 Super L Series 2 – page 6 of 6

© 1997 CASE CORPORATION
All Rights Reserved.

CASE CORPORATION
700 STATE STREET
RACINE, WI 53404 U.S.A.

CASE CANADA CORPORATION
450 SHERMAN AVENUE NORTH
HAMILTON, ON L8N 4C4 CANADA