

580M Loader/Backhoe



ENGINE

Model..... Case 4-390 diesel
 Type..... 4-stroke, naturally aspirated
 Cylinders..... 4
 Bore/Stroke 4.02" x 4.72"
 (102 x 120 mm)
 Displacement 239 in³ (3.9 L)
 Fuel injection..... Direct
 Fuel..... Diesel
 Fuel filter In-line strainer
 Air intake Cross-flow
 Cooling Liquid
 Engine speeds (rpm)
 Rated speed, full load 2200
 Low idle..... 900 - 975
 High idle, no load 2325 - 2425
 Horsepower
 Gross..... 75 (56 kW) @ 2200 rpm
 Net 73 (54 kW) @ 2200 rpm
 Maximum torque @ 1200 rpm
 Gross 201 lb-ft (273 N-m)
 Net 199 lb-ft (270 N-m)
 Torque rise at rated speed 12%

NOTE: Meets federal emission regulations.

ENGINE COOLING

Radiator (non air-conditioned)
 Core type..... Square wave
 Core size area 369 in² (.238 m²)
 Rows of tubes..... 4
 Fan
 Style 7 blade suction
 Diameter 19.2" (488 mm)
 Ratio 1.1:1
 Water pump
 Style Integral
 Engine oil
 Pump..... Deep sump plate cooler
 with pressurized
 under-piston nozzles
 Pump operating angle ratings
 Side-to-side Rated 45°
 Fore and aft..... Rated 45°
 Oil filtration..... Replaceable,
 full-flow cartridge

POWERTRAIN

Transmission... 4-speed synchromesh
 with hydraulically actuated
 clutches and electric
 F/R shuttle control, clutch
 disconnect buttons on the
 transmission shifter and
 loader control lever
 Gear ratios Forward Reverse
 1st..... 5.491 4.550
 2nd 3.043 2.522
 3rd 1.584 1.313
 4th 0.793 0.657
 Torque converter
 Ratio 3.337
 Differential lock..... On-the-go
 push-button activation
 Front axle
 Differential ratio 2.0
 Planetary hub ratio 6.0
 Total reduction ratio..... 12.0
 Rear axle
 Differential ratio 2.333
 Planetary hub ratio 6.923
 Total reduction ratio..... 16.153
 Service brakes... Individually applied,
 hydraulically actuated,
 maintenance-free, self-adjusting,
 inboard mounted, wet disc
 Disc area..... 53 in² (.03 m²)
 Parking brakes Mechanically
 applied with electric activation
 sensors at each brake
 Travel speeds – mph (km/h)
 1st 2nd 3rd 4th
 Forward 3.6 6.5 12.5 25.0
 (5.8) (10.5) (20.1) (40.2)
 Reverse 4.4..... 7.9 15.1 30.2
 (7.0) (12.6) (24.3) (48.6)

NOTE: Travel speeds at 2334 engine rpm with
 19.5L x 24 rear tires. Speeds decrease
 with 17.5L x 24 rear tires.

TIRES

Front
 2WD – 11L x 16.1, 10-ply rating
 4WD – 12 x 16.5, 8-ply rating
 Rear
 2/4WD – 17.5L x 24, 10-ply rating
 2/4WD – 19.5L x 24, 10-ply rating

HYDRAULICS

Pump Gear-type,
 front mounted, direct drive
 to engine crankshaft
 Loader flow @ rated engine rpm
 28.5 gpm @ 3050 psi
 (108 L/min @ 210 bar)
 Loader control valve..... Sectional
 2 or 3-spool with
 single lever control for
 lift, tilt and auxiliary hydraulics,
 positive hold float
 and return-to-dig
 Backhoe flow @ rated engine rpm
 28.5 gpm @ 3050 psi
 (108 L/min @ 210 bar)
 Backhoe control valve Sectional
 6, 7 or 8-spool, open-center
 parallel circuits with regeneration.
 Boom, dipper, and stabilizers with
 pilot operated check
 Loader auxiliary hydraulics
 12 to 28.5 gpm
 (45.4 to 108 L/min)
 Backhoe auxiliary hydraulics
 Uni-directional flow, with
 foot pedal activation
 19 to 28 gpm
 (72 to 106 L/min)
 Handheld auxiliary hydraulics
 7 to 17 gpm
 (26.5 to 64 L/min)
 Main relief pressure
 3050 + 50 - 50 psi @ 28.5 gpm
 (210 + 3 - 3 bar @ 108 L/min)
 Filtration 7-micron,
 full flow replaceable
 cartridge on return line, condition
 indicator light for filter
 Oil cooler..... Heavy-duty

ELECTRICAL

Voltage 12 volts, negative ground
 Alternator..... 65 amp (2.5 kW)
 Battery 685 cold-cranking amps
 Optional batteries..... (2) 525
 cold-cranking amps
 Power plugs (2) 30 amps ea.

OPERATOR ENVIRONMENT

ROPS/FOPS canopy
 Key start
 Hydrostatic steering
 Non-suspension seat w/180° swivel
 Hand and foot throttles
 Loader control lever w/push-button activation of differential lock and transmission de-clutch
 Backhoe foot-swing w/3 lever control
 (2) Accessory power plugs (30 amp)
 Anti-vandalism covers (canopy only)
 Cup holder
 Coat hook w/tether strap (cab only)
 Interior rearview mirror
 2" (51 mm) retractable seat belt
 Storage compartment w/lid
 Left side storage tray

INSTRUMENTATION

Gauges - back lit
 Engine water temperature
 Converter oil temperature
 Fuel
 Tachometer/hourmeter
 Voltmeter
 Warning lights
 Air cleaner restriction
 Alternator
 Engine oil pressure
 Hydraulic oil filter bypass
 Parking brake engagement
 Rear axle fluid temperature sensing system
 Low fuel
 Audible alarms
 Coolant temperature
 Engine oil pressure
 Parking brake engagement
 Shuttle engagement/seat position
 Backup alarm
 Turn signal indicators
 Horn - dual switched front & rear

TURNING DIAMETER

2WD
 Brakes on..... 21'3" (6.48 m)
 Brakes off..... 24'7" (7.49 m)
 4WD – engaged
 Brakes on..... 22'1" (6.72 m)
 Brakes off..... 28'3" (8.62 m)
 4WD – disengaged
 Brakes on..... 22'0" (6.70 m)
 Brakes off..... 25'3" (7.70 m)

NOTE: Turning diameter dimensions curb to curb w/19.5L x 24 rear tires and 82" (2.08 m) general purpose or 4 IN 1® bucket.

OPERATING WEIGHTS

Lightest Configuration
 Unit equipped with 2WD,
 ROPS/FOPS canopy, non-suspension seat, 82" (2.08 m) general purpose loader bucket, 24" (610 mm) general purpose backhoe bucket, standard dipperstick, 17.5L x 24 rear tires, 11L x 16.1 front tires, single battery, standard cast stabilizer pads, no operator 13,359 lb (6060 kg)

Heaviest Configuration
 Unit equipped with 4WD, cab, suspension seat, 82" (2.08 m) 4 IN 1® loader bucket, 24" (610 mm) general purpose backhoe bucket, Extendahoe® dipperstick, 19.5L x 24 rear tires, 12L x 16.5 front tires, dual batteries, flip stabilizer pads, no operator 16,510 lb (7489 kg)

Add-on weights

Cab (over canopy) ... +454 lb (206 kg)
 Counterweights..... +440 lb (200 kg) +900 lb (408 kg)
 Extendahoe® +430 lb (195 kg)
 4WD w/driveshaft guard..... + 283 lb (128 kg)

SERVICE CAPACITIES

Fuel tank 31.4 gal (119 L)
 Optional tank 40.0 gal (151 L)
 Hydraulic system
 Total 28.0 gal (106 L)
 Total w/Extendahoe® 29.5 gal (111.7 L)
 Reservoir w/filter.. 14.5 gal (54.9 L)
 Reservoir w/o filter ... 14.0 gal (53 L)
 Transmission
 2WD Total system .. 19.5 qt (18.5 L)
 4WD Total system .. 22.0 qt (20.8 L)
 4WD Front axle
 Differential..... 5.8 qt (5.5 L)
 Planetaries (each)..... 0.7 qt (0.66 L)
 Rear axle
 Differential..... 15.0 qt (14.2 L)
 Planetaries (each)..... 1.6 qt (1.5 L)
 Engine oil w/filter 11.6 qt (10.97 L)
 Cooling system
 w/heater 17.4 qt (16.5 L)
 w/o heater..... 16.7 qt (15.8 L)
 Window washer reservoir..... 2.5 qt (2.36 L)

LOADER

Single-lever control for lift and tilt
 Positive hold float
 Return-to-dig
 Automatic self-leveling
 In-line, reverse linkage
 Dual parallel dump cylinders
 Clutch disconnect button on loader control and shift levers
 Bucket position indicator

Loader Bucket Sizes

General Purpose Bucket

Width	Weight	Struck	Heaped
82" (2.08 m)	686 lb* (311 kg)	0.87 yd ³ (0.67 m ³)	1.03 yd ³ (0.79 m ³)
93" (2.36 m)	933 lb (423 kg)	1.07 yd ³ (0.82 m ³)	1.25 yd ³ (0.96 m ³)

4 IN 1® Bucket

Width	Weight	Struck	Heaped
82" (2.08 m)	1,462 lb (663 kg)	0.85 yd ³ (0.65 m ³)	1.04 yd ³ (0.80 m ³)

NOTE: *Add 103 lb (47 kg) to 82" (2.08 m) general purpose bucket for bolt-on cutting edge.

BACKHOE

Over-center design
 Cast, ductile iron boom, and swing tower w/5 year warranty
 Open-center hydraulics - Pro Control System
 175,800 lb-in (19 862 N-m) swing torque
 Foot-swing w/3 lever control
 Wing stabilizers w/cleated dirt pad

Backhoe Bucket Sizes

General Purpose Trenching Buckets

Width	Weight	Heaped
18" (457 mm)	255 lb (116 kg)	4.7 ft ³ (0.13 m ³)
24" (610 mm)	300 lb (136 kg)	6.26 ft ³ (0.17 m ³)
30" (762 mm)	380 lb (172 kg)	7.83 ft ³ (0.22 m ³)

Universal Buckets

Width	Weight	Heaped
12" (305 mm)	290 lb (132 kg)	3.40 ft ³ (0.10 m ³)
16" (406 mm)	346 lb (157 kg)	3.60 ft ³ (0.10 m ³)
18" (457 mm)	350 lb (159 kg)	5.30 ft ³ (0.15 m ³)
24" (610 mm)	413 lb (187 kg)	7.70 ft ³ (0.22 m ³)
30" (762 mm)	475 lb (215 kg)	10.20 ft ³ (0.29 m ³)
36" (914 mm)	535 lb (243 kg)	12.70 ft ³ (0.36 m ³)

High Capacity Heavy-Duty Bucket

Width	Weight	Heaped
24" (610 mm)	450 lb (204 kg)	8.50 ft ³ (0.24 m ³)

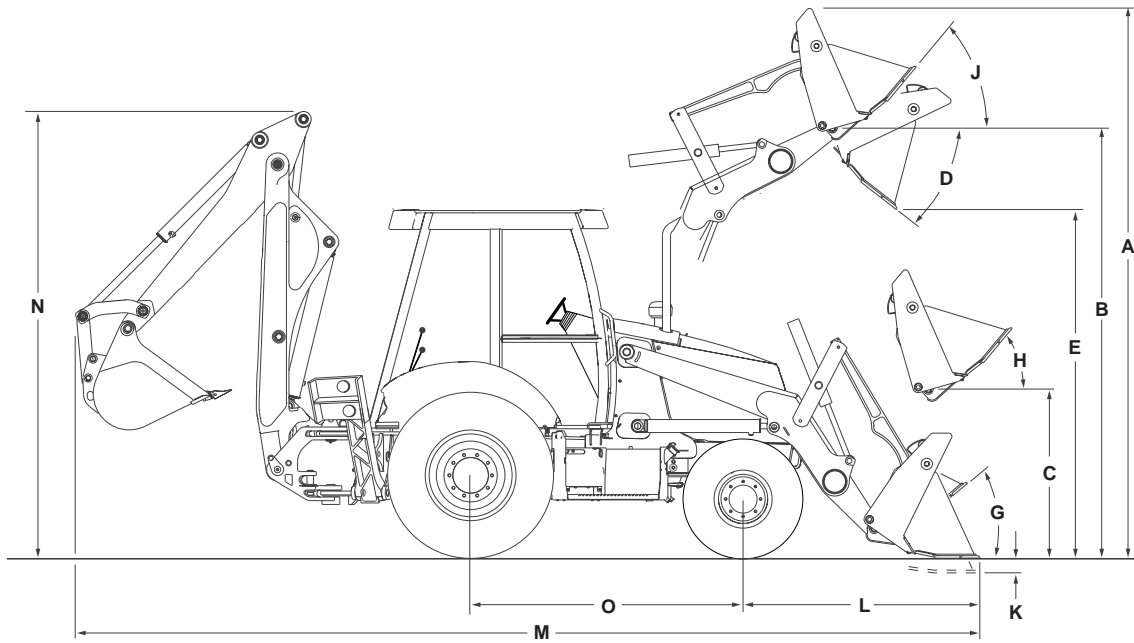

LOADER DIMENSIONS

General Purpose Bucket* 4 IN 1® Bucket

A. Overall operating height – fully raised	13'8" (4.17 m)	14'3" (4.34 m)
Height to –		
B. Bucket hinge pin fully raised.....	11'2" (3.4 m).....	11'2" (3.4 m)
C. Bucket hinge pin @ SAE carry	12.7" (323 mm)	14.6" (372 mm)
D. Dump angle @ full height.....	46°	45°
E. Dump clearance @ full height, 45° dump –		
Bucket.....	8'8" (2.64 m).....	8'11" (2.72 m)
Clam open.....	NA	9'8" (2.95 m)
F. Dump reach @ full height, 45° dump –		
Bucket	25.9" (657 mm)	25.4" (644 mm)
Clam open.....	NA	11.8" (300 mm)
Bucket rollback –		
G. @ groundline	40°	40°
H. @ SAE carry	45°	45°
J. @ full height.....	Adjustable.....	Adjustable
K. Digging depth below grade –		
Bucket flat.....	7.8" (199 mm)	7.1" (180 mm)
Clam open (dozing)	NA.....	4.4" (111 mm)
L. Reach from front axle centerline – bucket on ground	75.2" (1.91 m).....	72.7" (1.85 m)
Lift capacity to full height	6,182 lb (2804 kg)	5,514 lb (2501 kg)
Breakout force –		
Lift cylinders.....	9,164 lbf (40 760 N)....	8,904 lbf (39 600 N)
Dump cylinders	9,480 lbf (42 170 N) ..	10,325 lbf (45 820 N)
Bucket cutting edge width.....	82" (2.08 m)/93" (2.36 m).....	82" (2.08 m)
Maximum grading angle	116°.....	116°
Maximum clam opening.....	NA	38.3" (972 mm)
Moldboard height	NA	36.8" (934 mm)
Raising time to full height	5.3 sec.....	5.3 sec
Bucket dumping time.....	1.1 sec.....	1.1 sec
Lowering time –		
Power down	2.4 sec.....	2.4 sec
Return-to-dig.....	3.2 sec.....	3.2 sec
Clam –		
Open time	NA.....	2.3 sec
Close time	NA.....	3.1 sec

NOTE: Loader dimensions taken with 4WD,
19.5L x 24 rear tires and 82" (2.08 m) general
purpose bucket *without bolt-on cutting edge.

DIMENSIONS

	Standard Backhoe	Extendahoe®	
		Retracted	Extended
M. Overall transport length –			
General purpose bucket.....	23'0" (7.01 m)	23'0" (7.01 m)	NA
4 IN 1® bucket.....	22'10" (6.99 m)	22'10" (6.99 m)	NA
Overall transport width.....	7'2" (2.18 m)	7'2" (2.18 m)	NA
Height –			
To top of canopy.....	8'9" (2.66 m)	8'9" (2.66 m)	8'9" (2.66 m)
To top of cab.....	8'11" (2.72 m)	8'11" (2.72 m)	8'11" (2.72 m)
To top of exhaust stack.....	8'6" (2.60 m)	8'6" (2.60 m)	8'6" (2.60 m)
N. Transport.....	11'3" (3.42 m)	11'7" (3.53 m)	11'7" (3.53 m)
Ground clearance at backhoe frame.....	14.8" (376 mm)	14.8" (376 mm)	14.8" (376 mm)
Angle of departure.....	20°	20°	20°
Front wheel tread –			
2WD.....	67.5" (1.71 m)	67.5" (1.71 m)	67.5" (1.71 m)
4WD.....	67.7" (1.72 m)	67.7" (1.72 m)	67.7" (1.72 m)
Width across tires			
17.5L x 24.....	81.7" (2.074 m)	81.7" (2.074 m)	81.7" (2.074 m)
19.5L x 24.....	81.4" (2.67 m)	81.4" (2.67 m)	81.4" (2.67 m)
O. Wheelbase –			
2WD.....	84" (2.13 m)	84" (2.13 m)	84" (2.13 m)
4WD.....	84.5" (2.15 m)	84.5" (2.15 m)	84.5" (2.15 m)

NOTE: Dimensions taken with 19.5L x 24 rear tires and 11L x 16 front tires except that data marked 4WD is taken with 12 x 16.5 front tires.

CYLINDERS

	Bore Diameter	Rod Diameter	Stroke
Loader			
Lift (2).....	3.25" (82.6 mm)	1.75" (44.5 mm)	30.2" (766 mm)
Bucket (2).....	2.75" (69.9 mm)	1.5" (38.1 mm)	20.6" (522 mm)
4 IN 1® clam (2).....	3.0" (76 mm)	1.75" (44.5 mm)	9.1" (231 mm)
Backhoe			
Boom.....	4.5" (114 mm)	2.25" (57.2 mm)	38.6" (981 mm)
Dipperstick.....	4.25" (108 mm)	2.25" (57.2 mm)	27.0" (686 mm)
Bucket.....	3.25" (82.6 mm)	2.25" (57.2 mm)	34.3" (872 mm)
Extendahoe®.....	3.0" (76 mm)	1.75" (44.5 mm)	42.0" (1.07 m)
Swing (2).....	3.75" (95.3 mm)	2.0" (50.8 mm)	11.5" (292 mm)
Stabilizer (2).....	4.0" (101.6 mm)	2.0" (50.8 mm)	21.8" (553 mm)
Steering			
2WD.....	2.75" (69.9 mm)	1.5" (38.1 mm)	6.7" (170 mm)
4WD.....	2.48" (63 mm)	1.5" (38.1 mm)	9.53" (242 mm)

BACKHOE LIFT CAPACITIES

Boom Lift	Standard Backhoe		Retracted		Extendahoe®	
	Distance from swing pivot (m)	Backhoe lift capacity - lb (kg)	Distance from swing pivot (m)	Backhoe lift capacity - lb (kg)	Distance from swing pivot (m)	Backhoe lift capacity - lb (kg)
+16' (4.87 m)					12'7" (3.84)	810 (367)
+14' (4.27 m)	8'3" (2.52)	1,950 (885)	9'6" (2.89)	1,280 (581)	14'8" (4.47)	1,400 (635)
+12' (3.66 m)	10'9" (3.28)	2,700 (1225)	11'10" (3.61)	1,940 (880)	16'2" (4.93)	1,430 (649)
+10' (3.05 m)	12'7" (3.84)	2,700 (1225)	13'5" (4.09)	2,200 (998)	17'3" (5.26)	1,540 (699)
+8' (2.44 m)	13'6" (4.11)	2,750 (1247)	14'7" (4.45)	2,220 (1007)	18'1" (5.52)	1,610 (730)
+6' (1.83 m)	14'5" (4.40)	2,730 (1238)	15'3" (4.65)	2,260 (1025)	18'8" (5.69)	1,620 (735)
+4' (1.22 m)	14'9" (4.50)	2,720 (1234)	15'10" (4.82)	2,290 (1039)	19'0" (5.79)	1,660 (753)
+2' (0.61 m)	14'11" (4.55)	2,680 (1216)	16'0" (4.88)	2,290 (1039)	19'1" (5.82)	1,700 (771)
Ground Level	14'8" (4.47)	2,490 (1129)	15'11" (4.85)	2,270 (1030)	18'10" (5.74)	1,730 (785)
-2' (0.61 m)	14'3" (4.35)	2,440 (1107)	15'7" (4.75)	2,260 (1025)	18'6" (5.64)	1,720 (780)
-4' (1.22 m)	13'4" (4.06)	2,440 (1107)	14'10" (4.52)	2,240 (1016)	17'10" (5.43)	1,730 (785)
-6' (1.83 m)	12'0" (3.66)	2,440 (1107)	13'10" (4.21)	2,270 (1030)	17'0" (5.18)	1,740 (789)
-8' (2.44 m)	10'2" (3.10)	2,500 (1134)	12'6" (3.81)	2,350 (1066)	15'9" (4.80)	1,780 (807)
-10' (3.05 m)	7'0" (2.13)	2,780 (1261)	10'4" (3.15)	2,600 (1179)	14'1" (4.30)	1,870 (848)
-12' (3.66 m)					11'9" (3.58)	2,040 (925)
-14' (4.27 m)					8'1" (2.47)	2,610 (1184)
Dipper Lift						
+14' (4.27 m)					13'4" (4.06)	2,120 (962)
+12' (3.66 m)	9'9" (2.97)	3,950 (1792)	10'8" (3.25)	3,430 (1556)	14'2" (4.32)	2,210 (1002)
+10' (3.05 m)	10'4" (3.15)	3,690 (1674)	11'1" (3.38)	3,170 (1438)	14'6" (4.42)	2,200 (998)
+8' (2.44 m)	10'2" (3.10)	3,750 (1701)	11'0" (3.35)	3,240 (1470)	14'5" (4.40)	2,160 (980)
+6' (1.83 m)	9'4" (2.84)	4,100 (1860)	10'2" (3.10)	3,610 (1637)	13'10" (4.21)	2,230 (1012)
+4' (1.22 m)	7'6" (2.29)	4,710 (2136)	8'2" (2.49)	4,290 (1946)	12'10" (3.91)	2,420 (1098)

NOTE: Stated figures apply straight to the rear of prime mover. Equipped with 24" (610 mm) general purpose trenching bucket and links. For heavy-duty universal bucket and coupler, deduct 175 lb (79 kg) from each weight.

BACKHOE OPERATIONAL DATA

	Standard Backhoe		Retracted		Extendahoe®	
Digging depth –						
Maximum	14'3" (4.34 m)		14'10" (4.52 m)		18'3" (5.56 m)	
2' (610 mm) flat bottom	14'2" (4.32 m)		14'8" (4.47 m)		18'2" (5.54 m)	
8' (2.44 m) flat bottom	13'3" (4.04 m)		13'9" (4.19 m)		17'6" (5.33 m)	
Overall reach from –						
Rear axle centerline	21'5" (6.53 m)		22'0" (6.70 m)		25'5" (7.75 m)	
Swing pivot	17'10" (5.44 m)		18'5" (5.61 m)		21'10" (6.65 m)	
Loading height	11'1.6" (3.39 m)		11'4.6" (3.47 m)		13'25" (4.03 m)	
Loading reach – dipper retracted	8'9" (2.67 m)		8'8" (2.64 m)		11'6" (3.50 m)	
Swing arc	180°		180°		180°	
Bucket rotation –						
#1 position	170°		170°		170°	
#2 position	170°		170°		170°	
Stabilizer spread – operating	9'5" (2.87 m)		9'5" (2.87 m)		9'5" (2.87 m)	
Digging force –						
Bucket cylinder	11,212 lbf (49 873 N)		11,212 lbf (49 873 N)		11,212 lbf (49 873 N)	
Dipper cylinder	7,049 lbf (31 356 N)		6,686 lbf (29 741 N)		4,884 lbf (21 725 N)	
	w/bucket @ 46°		w/bucket @ 50°		w/bucket @ 55°	
Leveling angle						
maximum slope that backhoe will make vertical cut	12°		12°		12°	

STANDARD EQUIPMENT

OPERATOR'S COMPARTMENT

See page 2

ENGINE

Case 4-390 diesel
Automatic fan belt tensioner
Integral engine oil cooling
Fuel filter w/water trap
Air intake pre-cleaner
Dual element air cleaner
65 amp alternator
685 CCA 12-volt battery
Heavy-duty radiator w/coolant recovery bottle
Spark-arresting muffler

LOADER

See page 2

BACKHOE

See page 2

POWERTRAIN

2WD
4F/4R Power shuttle synchromesh transmission
Torque converter
Transmission de-clutch
Electro-hydraulic differential lock
Hydrostatic steering
Wet disc brakes

HYDRAULICS

2-spool loader control valve
6-spool backhoe control valve
Heavy-duty oil cooler

OTHER

Forward tilt engine hood
Replaceable, molded front bumpers
Front/rear tie downs
Reflective logos
Lights - Cab and Canopy
2 Rear tail/stop
2 Front flashers/turn
2 Rear flashers/turn
Cab only
4 Front & 4 rear adjustable halogen lights (55 w)
Canopy only
2 Front & 2 rear adjustable halogen lights (55 w)

OPTIONAL EQUIPMENT

OPERATOR'S COMPARTMENT

Cab with –
Heater
Defroster
Dome light - door activated w/switch
Wipers, front and rear
Tinted glass
Floor mat
Side window partial hold open
Inside release for side windows
Operator Convenience Package
Tilt wheel
Windshield washer w/adjustable nozzles (front & rear)
Sun visor
Deluxe Cab Package
Operator Convenience Package PLUS
Vinyl-covered interior
Radio-ready kit w/antenna and speakers
Reduced sound level to 72 dB(A)
Vinyl or cloth-covered mechanical suspension seat
Air Ride suspension seat
3" (76 mm) retractable seat belt
Cab air-conditioning, 100% filtered air, in-cab access filter, 8 adjustable roof vents, 2 floor vents, w/heater
Ride Control
Cab right door

Canopy Convenience package
Front windshield w/wiper & washer
85 dB(A) sound
Floor mat
Sun visor

ENGINE

Cold weather ether starting aid
Dual, 12-volt, 525 CCA batteries
Chaff screen
Fuel tank, 40 gal (151 L)

LOADER

Hydraulic front quick coupler
Attachment auxiliary hydraulics
3 spool valve hydraulics w/control
Buckets (see page 2)

BACKHOE

Case mechanical coupler
Attachment auxiliary hydraulics with hammer guard for boom
Buckets (see page 2)
Extendahoe®
Two-lever control
Stabilizer pads
Flip-over
Rubber pad
Front counterweights
440 lb (200 kg)
900 lb (408 kg)

POWERTRAIN

4WD w/outboard planetary drive, on-the-go push-button activation and 12 x 16.5 front tires

HYDRAULICS

Auxiliary hydraulics for handheld equipment

OTHER

Outside breakaway mirror
17.5L x 24 rear tires
19.5L x 24 rear tires
Tool box
Special paint
Lights - Canopy
Additional 2 front & 2 rear halogen lights (55 w)
Galaxy tires - Front
4WD 12 L x 16.5 Soft Flex-Poly Fill
Galaxy tires - Rear
2/4WD 19.5 L x 24 w/Tyrlyner™

NOTE: All specifications are stated in accordance with SAE Standards or Recommended Practices, where applicable.

Form No. CE 250-10-00
Replaces Form No: None

Case is a registered trademark of Case Corporation.



IMPORTANT: Case Corporation reserves the right to change these specifications without notice and without incurring any obligation relating to such change. Units shown may be equipped with non-standard equipment. Attachments from other manufacturers are shown for illustration only. Case Corporation does not warrant the safety or reliability of attachments from other manufacturers.

Visit Case Corporation on the Web at:
<http://www.casece.com>
Printed in U.S.A.

580M – page 6 of 6

© 2000 CASE CORPORATION
All Rights Reserved.

CASE CONSTRUCTION EQUIPMENT CONTACT INFORMATION

NORTH AMERICA/MEXICO
700 STATE STREET
RACINE, WI 53404 U.S.A.