



ENGINE

Model	FPT F5HFL463D
Emissions Certification	Tier 4 Final
Type	Diesel 4-stroke, Turbocharged
Cylinders	4
Bore/Stroke	3.90 x 4.33 in (99 x 110 mm)
Displacement	207 in ³ (3.4 L)
Fuel injection	Direct, high pressure common rail – HPCR
Fuel	Diesel
Engine speeds*	RPM
Rated speed – full load	2200
Low idle	900 – 1000
High idle – no load	2330 – 2430
Horsepower @ 2200 RPM:	
Gross	74 hp (55 kW)
Net w/ viscous fan**	72 hp (54 kW)
Net	68 hp (51 kW)
Maximum torque @ 1400 RPM:	
Gross	233 lb-ft (316 N-m)
Net w/ viscous fan	228 lb-ft (310 N-m)
Net	220 lb-ft (298 N-m)
Torque rise at rated speed	35% +/- 5%
Radiator:	
Core type	Square wave
Core size area	486 in ² (3 145 cm ²)
Rows of tubes	5
39° fan:	
Style	7 blade suction
Diameter	19.65 in (499 mm)
Ratio	1.1:1
Pump operating angle ratings:	
Side to side	Rated 35°
Fore and aft	Rated 35°
Oil filtration	Replaceable, full flow spin on

NOTE: *Meets federal emission regulations.

**Viscous fan available as DIA
w/ High Ambient Kit.

DRIVETRAIN

Transmission – standard:
4F-4R Power Shuttle Synchronesh
Transmission manual gear shift,
fully synchronized

Gear ratios	Forward/Reverse	
1st	5.603/4.643	
2nd	3.481/2.884	
3rd	1.584/1.313	
4th	0.793/0.657*	

Travel speeds	Forward	Reverse
	mph (kph)	mph (kph)
1st	3.5 (5.6)	4.2 (6.8)
2nd	5.5 (8.9)	6.6 (10.6)
3rd	11.8 (19.0)	14.1 (22.7)
4th	21.3 (34.3)	25.5 (41.0)

Torque converter ratio	3.2
Differential lock	On-the-go push-button activation

Front 4WD/Rear axle:	
Differential ratio	2.2/2.75
Planetary hub ratio	6.0/6.4
Total reduction ratio	13.3/17.6

Service brakes:	
Individually applied, power assisted, hydraulically actuated, maintenance-free, self-adjusting, outboard mounted, wet disc, 2 per side.	
Total disc area	384 in ² (0.25 m ²)

Parking brakes	Trans Mounted spring-applied hydraulic release – SAHR
----------------	--

NOTE: Travel speeds at 2293 engine
RPM specified: w/ 19.5 L x 24.0 tires.
Speeds decrease w/ 17.5 L x 24.0 rear tires.

ELECTRICAL

Voltage	12 Volts, negative ground
Alternator	120 amp
Battery	850 cold-cranking amps
Opt. batteries – 2	850 cold-cranking amps
Power plugs – 2	30 amps total

OPERATOR ENVIRONMENT

ROPS/FOPS certified protective canopy;
Rear fenders extensions; Coat hook w/ garment
strap; Interior rearview mirror, convex
3.54 in (90 mm) wide x 10.83 in (275 mm) high;
Non-suspension seat – 180° swivel – Vinyl; 2 in
(50 mm) retractable seat belt; Cup holder/storage
tray mounted on left-hand fender; Right-hand
storage compartment w/ lid.

Gauges:
Engine water temperature; Converter oil
temperature; Fuel level; Tachometer/
hourmeter; Voltmeter.

Warning lights:
Air cleaner restriction; Alternator; A/C high
pressure; Cold start; Engine oil pressure
low; Hydraulic oil filter bypass; Parking brake
engagement; Low fuel; Water in fuel.

Audible alarms:
Coolant temperature; Engine oil pressure;
Parking brake engagement; Shuttle
engagement/seat position; Backup;
Converter temperature; Particulate
Matter Regeneration.

Horn Dual switched front and rear

OPERATING WEIGHT

Configuration 1 – SAE Transport:

GP Loader Bucket, 2WD, Canopy, Boom
Guard, Full of Fuel, SAE Carry, Tier 4 Final
Engine, Extendahoe®, 4 Stick Mech BH,
Standard Transmission, 17.5 L – 24 Rear Tires,
700 lb Front Counterweight.

15,795 lb (7 164 kg)

Configuration 2 – SAE Transport:

GP Loader Bucket, 4WD, 2 Door Cab, AC,
Boom Guard, Full of Fuel, SAE Carry, 24 in HD
BH Bucket, Tier 4 Final Engine, Pilot Controls,
Standard Dipper, Manual Transmission,
19.5 – 24 Rear Tires.

15,810 lb (7 171 kg)

Add-on weights:

Cab-over canopy	309 lb (140 kg)
Fabricated stabilizer pads	141 lb (64 kg)
Counterweights	700 lb (318 kg)
Extendahoe®	285 lb (129 kg)
4WD w/ driveshaft guard	283 lb (128 kg)

HYDRAULICS

Pump: Parker P330 Single Section Gear Pump	
Main relief pressure: Standard 3,350 +/- 50 psi (231 +/- 3.5 bar)	
Filtration: 7-micron, return line, full flow, spin on element.	
Oil cooler	Heavy-duty
Loader flow @ rated engine RPM: 28.5 gpm @ 3,350 psi (108.0 L/min @ 231 bar)	
Loader control valve: Two or three-spool open center monoblock valve. Two and three-spool valves have a single lever manual control for lift and tilt functions. Three-spool valve uses a proportional Electro-Hydraulic control for the auxiliary function. The lift lever has a positive hold "Float" position and a "return-to-dig" feature. System Main Relief valve is single stage w/ Manual Backhoe Controls, dual stage relief valve w/ Pilot Backhoe Controls.	
Loader auxiliary hydraulics w/ proportional thumb switch w/ detent on loader control handle.	
Loader auxiliary hydraulics w/ full available flow: 0 – 28.5 gpm (0 – 108 L/min)	
Backhoe flow @ rated engine RPM: 28.5 gpm @ 3,350 psi (108 L/min @ 231 bar)	
Manual backhoe control valve: Six or seven-spool monoblock open center control valve. Basic control valve has an open center parallel circuit for all functions.	

Pilot backhoe control valve:
Six, seven or eight-spool sectional closed center control valve. Basic control valve is closed center, w/ circuits in parallel w/ a post-compensated, flow sharing feature for simultaneous operation of all circuits.

Unidirectional auxiliary hydraulics:
Unidirectional hydraulic valve is equipped w/ an adjustable LS relief valve to control attachment pressure and a 6 position flow control selector for 6 detented, distinct flow settings.

Actuation:
Manual backhoe controls – cab floor pedal
Pilot controls – left-hand joystick

Bidirectional auxiliary hydraulics*:
Actuation:
Activated the bidirectional Switch located on the rear console
Manual shift – bidirectional linkage on far right of backhoe tower
Pilot controls – left-hand joystick

NOTE: *Available w/ Combo Aux. Hyd. option.

SERVICE CAPACITIES

Fuel tank	30.0 gal (114.0 L)
Hydraulic system:	
Total	106 qt (100.0 L)
w/ Extendahoe®	112 qt (106.0 L)
Reservoir w/ filter	58 qt (55.0 L)
Reservoir w/o filter	56 qt (53.0 L)
Transmission – total system:	
2WD Standard	18 qt (17.0 L)
2WD Powershift	23 qt (21.7 L)
4WD Standard	21 qt (19.4 L)
4WD Powershift	22 qt (20.7 L)

Front axle:	
4WD Differential	5.8 qt (5.5 L)
4WD Planetaries – each	0.7 qt (0.7 L)
Rear axle:	
Differential and planetaries	14.4 qt (13.6 L)
Engine oil w/ filter	8.5 qt (8.0 L)
Cooling system:	
w/ heater	19.0 qt (18.0 L)
w/o heater	18.3 qt (17.3 L)
Window washer reservoir	3.0 qt (2.8 L)

OTHER SPECIFICATIONS

Front tires:	
2WD	11.0 L x 16.0, 10-ply rating
4WD	12.0 L x 16.5, 8-ply rating
Rear tires:	
2/4WD	19.5 L x 24.0, 10-ply rating
2/4WD	17.5 L x 24.0, 10-ply rating
Loader: Bucket position indicator; Lifting lugs on standard bucket; Single lever control w/ self-leveling and return-to-dig; Hand operated clutch disconnects on loader and shift levers, single lever 4-function loader control: lift, dump, clutch cut-out, differential lock.	
Turning radius*: Curb to Curb	
2WD:	
Brakes on	10 ft 8 in (3.24 m)
Brakes off	12 ft 4 in (3.76 m)
4WD – engaged:	
Brakes on	11 ft 4 in (3.45 m)
Brakes off	13 ft 10 in (4.21 m)
4WD – disengaged:	
Brakes on	11 ft 0 in (3.36 m)
Brakes off	12 ft 3 in (3.72 m)
Backhoe: Over center design, Fabricated "S" boom.	
NOTE: *Turning radius dimensions curb to curb w/ 17.5 L x 24.0 rear tires.	

LOADER BUCKET SIZES

Type	Width	Weight	Struck	Heaped Capacity
Long Lip Bucket without bolt-on edge	82 in (2.08 m)	683 lb (310 kg)	0.88 yd ³ (0.67 m ³)	1.03 yd ³ (0.79 m ³)
	93 in (2.36 m)	1,188 lb* (539 kg)	1.10 yd ³ (0.89 m ³)	1.29 yd ³ (0.99 m ³)
4 IN 1® Bucket with bolt-on edge	82 in (2.08 m)	1,572 lb* (713 kg)	0.85 yd ³ (0.65 m ³)	1.05 yd ³ (0.80 m ³)

NOTE: *Weight of 4 IN 1® bucket includes edges, cylinders and tube lines.

BACKHOE BUCKET SIZES

Type	Width	Weight	Heaped Capacity
General Purpose Trenching Buckets	18 in (457 mm)	232 lb (105 kg)	4.70 ft ³ (0.13 m ³)
	24 in (610 mm)	272 lb (123 kg)	6.26 ft ³ (0.18 m ³)
Universal Buckets	12 in (305 mm)	295 lb (134 kg)	3.40 ft ³ (0.10 m ³)
	18 in (457 mm)	356 lb (162 kg)	5.30 ft ³ (0.15 m ³)
	24 in (610 mm)	427 lb (194 kg)	7.70 ft ³ (0.22 m ³)
	30 in (762 mm)	489 lb (222 kg)	10.20 ft ³ (0.29 m ³)
	36 in (914 mm)	552 lb (251 kg)	12.70 ft ³ (0.36 m ³)
High Capacity Buckets	24 in (610 mm)	447 lb (203 kg)	8.50 ft ³ (0.24 m ³)

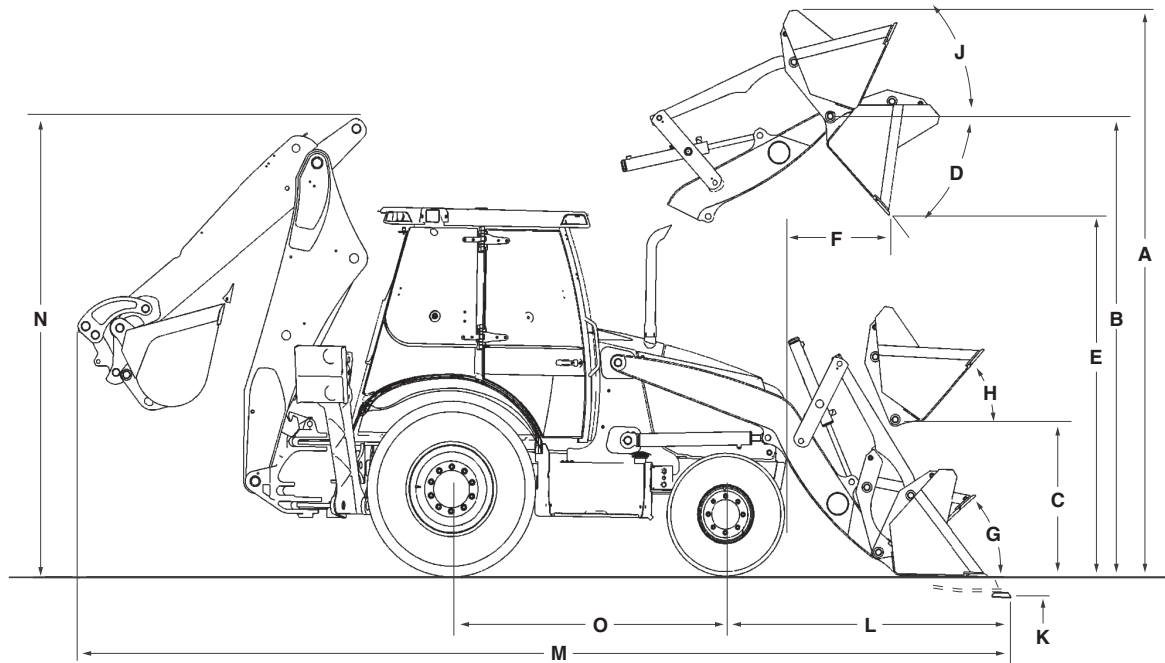

Line drawings are for illustrative purpose only and may not be exact representation of unit.

LOADER DIMENSIONS

	Long Lip Bucket	4 IN 1® Bucket
A. Overall operating height – fully raised	13 ft 9 in (4.17 m)	14 ft 4 in (4.35 m)
Height to:		
B. Bucket hinge pin fully raised	11 ft 3 in (3.41 m)	11 ft 3 in (3.41 m)
C. Bucket hinge pin at SAE carry	12.8 in (326 mm)	14.6 in (371 mm)
D. Dump angle at full height	46°	46°
E. Dump clearance at full height, 45° dump:		
Bucket	8 ft 8 in (2.63 m)	8 ft 11 in (2.71 m)
Clam open	–	9 ft 8 in (2.93 m)
F. Dump reach at full height, 45° dump:		
Bucket	26.7 in (679 mm)	26.2 in (666 mm)
Clam open	–	12.6 in (321 mm)
Bucket rollback:		
G. @ Groundline	40°	40°
H. @ SAE carry	43°	43°
J. @ Full height	Adjustable	Adjustable
K. Digging depth below grade:		
Bucket flat	7.8 in (199 mm)	7.1 in (180 mm)
Clam open – dozing	–	4.4 in (111 mm)
L. Reach from front axle centerline – bucket on ground	6 ft 10 in (2.08 m)	6 ft 8 in (2.03 m)
Lift capacity to full height	6,503 lb (2 950 kg)	6,537 lb (2 965 kg)
Breakout force:		
Lift cylinders	9,271 lb (4 124 daN)	8,904 lb (3 961 daN)
Dump cylinders	9,607 lb (4 273 daN)	10,302 lb (4 583 daN)
Bucket cutting edge width	82.5 in (2.09 m)	82.0 in (2.08 m)
Maximum grading angle	114°	114°
Maximum clam opening	–	38.3 in (972 mm)
Moldboard height	–	36.8 in (934 mm)
Raising time to full height	3.3 sec	3.3 sec
Bucket dumping time	0.8 sec	0.8 sec
Lowering time:		
Power down	2.4 sec	2.4 sec
Return-to-dig	4.4 sec	4.4 sec
Clam:		
Open time	–	1.3 sec
Close time	–	1.1 sec

NOTE: Loader dimensions taken with 4WD, 19.5 L x 24.0 rear tires.

DIMENSIONS

	2WD with 19.5 L x 24.0 tires	4WD with 19.5 L x 24.0 tires
M. Overall transport length:		
Long Lip bucket with Universal Coupler	23 ft 1 in (7.02 m)	23 ft 0 in (7.00 m)
4 IN 1® bucket with Universal Coupler	22 ft 10 in (6.96 m)	22 ft 9 in (6.93 m)
Long Lip bucket with Straight Links	23 ft 2 in (7.04 m)	23 ft 0 in (7.00 m)
4 IN 1® bucket with Straight Links	22 ft 11 in (6.98 m)	22 ft 10 in (6.95 m)
Overall transport width – rear tires	7 ft 2 in (2.17 m)	7 ft 2 in (2.17 m)
Height:		
To top of canopy	8 ft 9 in (2.66 m)	8 ft 9 in (2.66 m)
To top of cab	8 ft 11 in (2.72 m)	8 ft 11 in (2.72 m)
To top of exhaust stack	8 ft 7 in (2.62 m)	8 ft 7 in (2.61 m)
N. Transport - standard dipper	10 ft 10 in (3.30 m)	11 ft 1 in (3.37 m)
Ground clearance at backhoe frame	15.0 in (380 mm)	15.0 in (380 mm)
Angle of departure	15.3°	19.0°
Front wheel tread:		
11.0 L x 16.0	67.5 in (1.71 m)	67.5 in (1.71 m)
12.0 L x 16.5	67.7 in (1.72 m)	67.7 in (1.72 m)
Rear wheel tread:		
17.5 L x 24.0	63.1 in (1.60 m)	63.1 in (1.60 m)
19.5 L x 24.0	61.2 in (1.55 m)	61.2 in (1.55 m)
Width over tires:		
11.0 L x 16.0	79.3 in (2.01 m)	79.3 in (2.01 m)
12.0 L x 16.5	81.1 in (2.06 m)	81.1 in (2.06 m)
17.5 L x 24.0	81.7 in (2.07 m)	81.7 in (2.07 m)
19.5 L x 24.0	81.4 in (2.07 m)	81.4 in (2.07 m)
O. Wheelbase	84.0 in (2.13 m)	84.5 in (2.15 m)

CYLINDERS

	Bore Diameter	Rod Diameter	Stroke	Closed Length
Loader:				
Lift – 2	3.25 in (82.6 mm)	1.75 in (44.5 mm)	30.2 in (766.0 mm)	40.80 in (1 036.0 mm)
Dump – 2	3.00 in (76.2 mm)	1.50 in (38.1 mm)	20.6 in (522.0 mm)	30.70 in (780.5 mm)
4 IN 1® clam – 2	3.00 in (76.2 mm)	1.75 in (44.5 mm)	9.18 in (230.6 mm)	19.69 in (498.3 mm)
Backhoe:				
Boom	4.50 in (114.3 mm)	2.25 in (57.2 mm)	38.25 in (971.6 mm)	52.82 in (1 341.6 mm)
Dipperstick	4.25 in (108.0 mm)	2.25 in (57.2 mm)	24.74 in (628.5 mm)	39.65 in (1 007.0 mm)
Bucket	3.25 in (82.6 mm)	2.25 in (57.2 mm)	35.35 in (897.9 mm)	48.17 in (1 223.6 mm)
Extendahoe®	3.00 in (76.2 mm)	1.75 in (44.5 mm)	42.05 in (1 068.0 mm)	56.22 in (1 428.0 mm)
Swing – 2	3.75 in (95.3 mm)	2.00 in (50.8 mm)	11.50 in (292.0 mm)	24.44 in (620.8 mm)
Stabilizer – 2	4.00 in (101.6 mm)	2.00 in (50.8 mm)	21.78 in (553.3 mm)	33.80 in (858.5 mm)

AXLE RATINGS

	Front – 2WD	Rear	Front – 4WD
Maximum static	70,821 lb (32 124 kg)	90,145 lb (40 889 kg)	64,613 lb (29 308 kg)
Dynamic operating	44,261 lb (20 076 kg)	56,200 lb (25 492 kg)	39,328 lb (17 839 kg)
Static operating	17,704 lb (8 030 kg)	22,480 lb (10 197 kg)	15,732 lb (7 136 kg)
Oscillation – front axle	22° total – 11° side to side	–	22° total – 11° side to side

BACKHOE LIFT CAPACITIES

Standard Backhoe		Extendahoe®	
Boom Lift	Lift Capacity lb (kg)	Retracted Lift Capacity lb (kg)	Extended Lift Capacity lb (kg)
+16 ft (4.87 m)	—	—	1,693 (768)
+14 ft (4.27 m)	2,472 (1 121)	2,271 (1 030)	1,979 (897)
+12 ft (3.66 m)	2,857 (1 296)	2,644 (1 199)	2,124 (964)
+10 ft (3.05 m)	2,966 (1 345)	2,748 (1 246)	2,172 (985)
+8 ft (2.44 m)	2,983 (1 353)	2,761 (1 252)	2,169 (984)
+6 ft (1.83 m)	2,963 (1 344)	2,739 (1 242)	2,173 (985)
+4 ft (1.22 m)	2,929 (1 329)	2,701 (1 225)	2,165 (982)
+2 ft (0.61 m)	2,892 (1 312)	2,662 (1 207)	2,153 (977)
Ground Level	2,858 (1 297)	2,625 (1 191)	2,153 (977)
-2 ft (0.61 m)	2,834 (1 285)	2,598 (1 178)	2,145 (973)
-4 ft (1.22 m)	2,827 (1 282)	2,588 (1 174)	2,143 (972)
-6 ft (1.83 m)	2,853 (1 294)	2,609 (1 183)	2,154 (977)
-8 ft (2.44 m)	2,949 (1 338)	2,698 (1 224)	2,189 (993)
-10 ft (3.05 m)	3,319 (1 506)	3,053 (1 385)	2,270 (1 030)
-12 ft (3.66 m)	—	—	2,429 (1 102)
-14 ft (4.27 m)	—	—	3,115 (1 413)
Dipper Lift			
+14 ft (4.27 m)	—	—	3,154 (1 431)
+12 ft (3.66 m)	4,343 (1 970)	4,139 (1 877)	2,981 (1 352)
+10 ft (3.05 m)	4,027 (1 827)	3,826 (1 735)	2,823 (1 281)
+8 ft (2.44 m)	4,112 (1 865)	3,910 (1 774)	2,855 (1 295)
+6 ft (1.83 m)	4,563 (2 070)	4,357 (1 976)	3,010 (1 365)
+4 ft (1.22 m)	5,398 (2 449)	5,177 (2 348)	2,948 (1 337)
+2 ft (0.61 m)	—	—	3,486 (1 581)

BACKHOE OPERATIONAL DATA*

	Standard Backhoe	Extendahoe®	
		Retracted	Extended
Digging depth:			
Maximum	15 ft 0 in (4.58 m)	15 ft 0 in (4.58 m)	18 ft 6 in (5.63 m)
2 ft (610 mm) flat bottom	14 ft 11 in (4.54 m)	14 ft 11 in (4.54 m)	18 ft 4 in (5.95 m)
8 ft (2.44 m) flat bottom	13 ft 11 in (4.24 m)	13 ft 11 in (4.24 m)	17 ft 7 in (5.36 m)
Overall reach from:			
Rear axle centerline	21 ft 11 in (6.68 m)	21 ft 11 in (6.68 m)	25 ft 4 in (7.72 m)
Swing pivot	18 ft 6 in (5.65 m)	18 ft 6 in (5.65 m)	21 ft 11 in (6.68 m)
Loading height	11 ft 7 in (3.53 m)	11 ft 7 in (3.53 m)	13 ft 11 in (4.24 m)
Loading reach	4 ft 7 in (1.39 m)	4 ft 7 in (1.39 m)	7 ft 2 in (2.18 m)
Swing arc	180°	180°	180°
Bucket rotation:			
Straight links	175.6°	175.6°	175.6°
Mechanical coupler	198.0°	198.0°	198.0°
Universal coupler	190.0°	190.0°	190.0°
Stabilizer spread – centers:			
Flip pad	9 ft 5 in (2.87 m)	9 ft 5 in (2.87 m)	9 ft 5 in (2.87 m)
Cast Pad	9 ft 9 in (2.97 m)	9 ft 9 in (2.97 m)	9 ft 9 in (2.97 m)
Digging force – Quick Coupler:			
Bucket cylinder	11,517 lb (51 228 N)	11,517 lb (51 228 N)	11,517 lb (51 228 N)
Dipper cylinder	6,710 lb (29 484 N)	6,710 lb (29 484 N)	4,895 lb (21 738 N)
Leveling angle:			
Flip pad	12°	12°	12°
Cast pad	13°	13°	13°

NOTE: *Dimensions taken with 2WD, 17.5 L x 24 Rear tires, Universal coupler.

STANDARD EQUIPMENT

OPERATOR ENVIRONMENT

See page 1

ENGINE

FPT F5HFL463D diesel
Full flow engine oil filter
Air cleaner – replaceable dry type
with radial seal
Aspirated air cleaner
Particulate Matter Catalyst – spark arresting
Radiator with de-aeration bottle
Antifreeze to -34° F (-37° C)
Throttles, both hand rotary and foot
Self adjusting belt

DRIVETRAIN

Front axle, as selected:
2WD heavy-duty front axle with
11.0 L x 16.0 tires
4WD heavy-duty mechanically driven
front axle, with 12.0 L x 16.5 tires
Rear axle:
2/4WD heavy-duty outboard planetary
drive, with 17.5 L x 24.0 tires
4F-4R Power Shuttle
Synchromesh transmission
Torque converter – 11.8 in (300 mm)
On-the-go electric 4WD control
Electric F/R shuttle control
Electric differential lock control,
with push-button activation on the
loader control lever
Park brake, spring-applied, hydraulic
release - SAHR

HYDRAULICS

Pump:
28.5 gal/min @ 3,350 psi
(107.9 L/min @ 231 bar)
Heavy-duty hydraulic oil cooler
7-micron, spin on oil filter

LOADER

See page 2

BACKHOE

See page 2

OTHER

Forward tilt engine hood
Replaceable, molded front bumpers
Front/Rear tie downs
Reflective logos
Lights – cab and canopy:
2 rear tail/stop
2 front flashers/turn
2 rear flashers/turn
2 front driving lights – 55 W
Adjustable halogen work lights – 55 W:
2 side – left and right, cab only

TELEMATICS

CASE SiteWatch™ Telematics – includes
hardware and a 3-yr Advanced
data subscription

OPTIONAL EQUIPMENT

OPERATOR ENVIRONMENT

Auto Ride Control – 4WD models
Standard Ride Control – 2WD models
Comfort Steering with momentary latching switch, two-speed steering pump and 3rd/4th gear cutout
ROPS/FOPS certified protective cab with rear wipers and floor mat
Cab Convenience Package containing pull-down sun visor, window washer – front and rear, left-hand storage tray, deluxe interior package, tilt steering column, Sound Reduction Package for cab models – levels reduced to 72 dB (A), right-hand threshold storage box, viscous fan
Air-conditioning for cab models
Mechanical suspension seat with flip-up armrests, 180° swivel, cloth or vinyl, adjustable seat and weight, backrest angle, lumbar and cushion angle
Air Ride suspension seat with flip-up armrests, 180° swivel, electric height adjustment, adjustable backrest and lumbar support – cab units cloth, canopy units vinyl
Pull-down sun visor for canopy models
Radio, AM/FM Stereo/WB, MP3 auxiliary input – cab models
3 in (75 mm) seat belt for mechanical and air-suspension seat
Anti-vandalism cover for dash-canopy only

ENGINE

Cold Weather Starting Aid
with dual 12 Volt batteries and glow plugs
Block heater

DRIVETRAIN

Heavy-duty outboard planetary drive
without 19.5 L x 24.0 tires
Drive shaft guard

LOADER

Auxiliary hydraulics for loader-mounted equipment with thumb-operated proportional control
Hydraulic front quick coupler
Loader linkage without loader bucket
Tool portfolio of additional attachments
Buckets – see page 2

BACKHOE

Auxiliary backhoe unidirectional hydraulics
Auxiliary backhoe combo hydraulics:
Hand lever operated for bidirectional manual controls
Button operated for pilot controls, includes unidirectional and bidirectional
Flow from 0 to 28.5 gal/min (0 to 108 L/min)
Extendahoe®
Two-lever controls – backhoe or Extendahoe®

Pilot operated control system:
Fingertip proportional Electro-Hydraulic stabilizer controls
Thumb-operated proportional Electro-Hydraulic Extendahoe® control
Thumb-operated horn button
Thumb-operated auxiliary hydraulic control
Infinitely adjustable towers
In-cab switchable “excavator to backhoe” control pattern change
Flip over stabilizer pads
Cemetery/Street pads
Case mechanical quick coupler
Universal coupler – CAT/Deere compatible
Pro Control Swing dampening
Buckets – see page 2

OTHER

Front:
11.0 L x 16.0 10-ply or 12.0 L x 16.5 8-ply
Rear:
17.5 L x 24.0 10-ply or 19.5 L x 24.0 10-ply
Special paint
Lights:
Additional 2 front and 2 rear halogen lights – 55 W
Adjustable side work lights – canopy
Tool box – bolt-on, step-mounted
Front counterweights:
440 lb and 900 lb (200 kg and 408 kg)
Rotating beacon
Master disconnect switch and remote jump-start terminals

CaseCE.com

©2016 CNH Industrial America LLC. All rights reserved. CASE is a trademark registered in the United States and many other countries, owned by or licensed to CNH Industrial N.V., its subsidiaries or affiliates. CNH Industrial Capital is a trademark in the United States and many other countries, owned by or licensed to CNH Industrial N.V., its subsidiaries or affiliates. Printed in U.S.A. Contains 10% post-consumer fiber.

IMPORTANT: CASE Construction Equipment Inc. reserves the right to change these specifications without notice and without incurring any obligation relating to such change. Availability of some models and equipment builds vary according to the country in which the equipment is used. The illustrations and text may include optional equipment and accessories and may not include all standard equipment. Your CASE dealer/distributor will be able to give you details of the products and their specifications available in your area.



CASE Construction Equipment is biodiesel-friendly. NOTE: All engines meet current EPA emissions regulations. All specifications are stated in accordance with SAE Standards or Recommended Practices, where applicable.



Always read the Operator's Manual before operating any equipment. Inspect equipment before using it, and be sure it is operating properly. Follow the product safety signs and use any safety features provided.

Form No. CCE201603580NEPT4
Replaces Form No. CCE201408580NEP

580N EP

7 of 7

Courtesy of Machine.Market