

### D SERIES HIGHLIGHTS

- **Maximizes speed and efficiency while reducing fuel consumption**
- **Outstanding visibility and standard rearview camera**
- **Three power modes = the ideal mix of power and fuel efficiency**
- **Color monitor with constant rear camera view and performance data**
- **Exceptionally smooth and quiet ride, and extra-spacious, climate controlled cab and hands-free calls with Bluetooth radio**
- **Robust arm, boom, and EMS bushings design = 5x better durability**
- **Hydraulic quick coupler fastens and locks attachments from the cab**
- **Stronger undercarriage reduces dirt accumulation and eases cleaning**
- **6 LED working lights package provides great night visibility with 3x the brightness of halogen lights and includes side view camera**



### DO MORE IN LESS TIME

The CX210D's new electronically controlled hydraulic pump and larger control and solenoid valves boost breakout force, increase lifting strength and improve responsiveness, enabling faster cycle times and the machine to work up to 9% faster. Your operators will get more done in less time.

### SCR SAVES FUEL WITHOUT SACRIFICING POWER

The CX210D employs an SCR Tier 4 Final solution that provides up to 5% greater fuel efficiency while providing exceptional power. SCR lets the engine run at peak performance throughout the work cycle and, because it works without a Diesel Particulate Filter, there's no DPF regeneration or costly filter to worry about replacing.



Three Power Modes



7" Color Monitor



SCR Tier 4 Final

### NEW STANDARD FEATURES

- **Control Pattern Selector**  
Effortlessly switch between ISO and SAE patterns
- **Free-Swing Feature**  
Improved control when craning, pipe laying or lifting offset loads
- **Oil Sample Ports**  
Easily make quick visual checks of engine and hydraulic oils
- **Heated, Air-Ride Seat**  
Year-round comfort
- **Bluetooth Radio**  
Hands-free phone use
- **Additional Handrails**  
Get around the machine easier than ever

NOTE: Improvements and percentages are in reference to CASE C Series excavators.



CASE ProCare — the industry's best all-in-one heavy machine support program that's as powerful as the equipment it protects — comes standard on all D Series excavators. ProCare includes:

- 3K** 3-year/3000-hr. Full-Machine Factory Warranty\*
- 3** 3-year/3000-hr. Planned Maintenance
- 3** 3-year Advanced SiteWatch™ Subscription

\*See your dealer for the complete terms of CNH's Warranty and Limitation of Liability, which contains certain limits and exclusions.

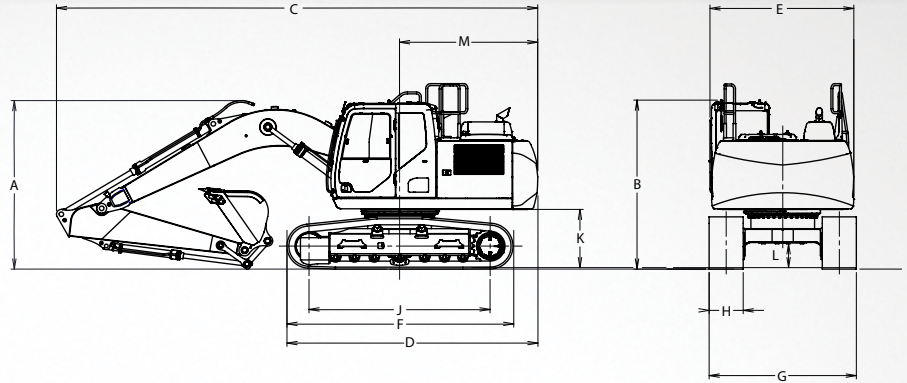

Line drawings are for illustrative purpose only and may not be exact representation of unit.

DIMENSIONS	CX210D LC	CX210D LC
	9 ft 8 in (2.94 m) Arm <sup>1</sup>	7 ft 10 in (2.4 m) HD Arm <sup>2</sup>
A. Overall Height – With Attachment	10 ft. 9 in. (3 280 mm)	10 ft. 9 in. (3 280 mm)
B. Cab Height	9 ft. 10 in. (2 990 mm)	9 ft. 10 in. (2 990 mm)
C. Overall Length – With Attachment	30 ft. 11 in. (9 430 mm)	31 ft. 2 in. (9 510 mm)
D. Overall Length – Without Attachment	16 ft. 5 in. (5 000 mm)	16 ft. 5 in. (5 000 mm)
E. Width Of Upper Structure – with Catwalks	9 ft. 1 in. (2 770 mm)	9 ft. 1 in. (2 770 mm)
F. Track Overall Length	14 ft. 8 in. (4 470 mm)	14 ft. 8 in. (4 470 mm)
G. Track Overall Width with 31.5 in. (800 mm) shoes	10 ft. 6 in. (3 190 mm)	10 ft. 6 in. (3 190 mm)
H. Track Shoe Width	31.5 in. (800 mm)	31.5 in. (800 mm)
J. Center To Center - Idler To Sprocket	12 ft. 0 in. (3 660 mm)	12 ft. 0 in. (3 660 mm)
K. Uppers Structure Ground Clearance	3 ft. 5 in. (1 050 mm)	3 ft. 5 in. (1 050 mm)
L. Minimum Ground Clearance	1 ft. 5 in. (440 mm)	1 ft. 5 in. (440 mm)
M. Rear Tail Swing Radius	9 ft. 2 in. (2 790 mm)	9 ft. 2 in. (2 790 mm)

<sup>1</sup> With 18 ft 8 in (5.70 m) boom, 9 ft 8 in (2.94 m) arm, 31.5 in (800 mm) track shoe, 1,433 lb (650 kg) bucket, full fuel tank and standard equipment.

<sup>2</sup> With 18 ft 8 in (5.70 m) boom, 7 ft 10 in (2.4 m) arm, 31.5 in (800 mm) track shoe, 1,433 lb (650 kg) bucket, full fuel tank and standard equipment.

SPECIFICATIONS*	CX210D LC 9 ft 8 in (2.94 m) Arm	CX210D LC 7 ft 10 in (2.4 m) HD Arm
Engine	Isuzu AR-4HK1X	Isuzu AR-4HK1X
Emissions Certification	Tier 4 Final	Tier 4 Final
Net HP – hp (kW)	160 (119) @ 1800 RPM	160 (119) @ 1800 RPM
Bucket Digging Force* – lbf. (kN) – with Power Boost	34,621 (154)	34,621 (154)
Arm Digging Force – lbf. (kN) – with Power Boost	25,179 (112)	29,900 (133)
Maximum Digging Depth – ft. in. (mm)	21 ft. 10 in. (6 650 mm)	20 ft. 1 in. (6 110 mm)
Operating Weight – lb. (kg)	48,973 (22 214)	48,859 (22 162)
Swing Torque – lbf-ft (kN-m)	47,204 (64.0)	47,204 (64.0)
Drawbar Pull – lbf. (kN)	42,264 (188)	42,264 (188)

NOTE: \*Digging force based on ISO6015 and Standard boom and arm.

### MAINTENANCE MADE EASY.

From standard oil sample ports and grouped service points to tilt-out coolers and auto-locking side panels, you can do daily maintenance in a matter of minutes.



©2015 CNH Industrial America LLC. All rights reserved. CASE is a trademark registered in the United States and many other countries, owned by or licensed to CNH Industrial N.V., its subsidiaries or affiliates. CNH Industrial Capital is a trademark in the United States and many other countries, owned by or licensed to CNH Industrial N.V., its subsidiaries or affiliates. Printed in U.S.A.

Form No. CCE201503CX210D  
Replaces Form No.CCE201502CX210D



### SAFETY™ NEVER HURTS

Always read the Operator's Manual before operating any equipment. Inspect equipment before using it, and be sure it is operating properly. Follow the product safety signs and use any safety features provided.

NOTE: All engines meet current EPA emissions regulations.

NOTE: All specifications are stated in accordance with SAE Standards or Recommended Practices, where applicable.



Contains 10% post-consumer fiber

IMPORTANT: CASE Construction Equipment Inc. reserves the right to change these specifications without notice and without incurring any obligation relating to such change. Availability of some models and equipment builds vary according to the country in which the equipment is used. The illustrations and text may include optional equipment and accessories and may not include all standard equipment. Your CASE dealer/distributor will be able to give you details of the products and their specifications available in your area.



CASE construction equipment is biodiesel-friendly.