

CASE
CONSTRUCTION

CX75C SR | CX80C EXCAVATORS



CX75C SR/CX80C Excavators

SMALLER SIZE. BIGGER BENEFITS.

The new C Series midi-excavators are an impressive story of less is more. A first-in-class, DOC Tier 4 Final engine uses up to 5% less fuel and greater serviceability access minimizes downtime. Reduced dimensions allow these excavators to perform in tight work spaces.

But they offer more where it counts. More hydraulic power, more reach, more roominess in the cab and more options to suit more applications. It's a versatile machine that's built small for big jobs.



CX75C SR | CX80C

Highlights

- 1 No DPF regeneration** with Diesel Oxidation Catalyst (DOC) Tier 4 Final engine uses up to 5% less fuel compared to previous generations.
- 2** An optimized system produces **9% more hydraulic power** and **3% more breakout force** than previous generations for even greater digging power and responsiveness.
- 3 20% larger fuel tank** to keep you up and running longer between fill ups.
- 4 7% wider cab** with improved climate control features, greater all-around visibility and a standard full-color 7" monitor. 11% more foot space.
- 5 Proportional joystick** controls (standard with any hydraulic package) give you more control of your attachments in applications requiring precise work.
- 6 3 Boom types** for every need: The OFFSET BOOM – increases working area without repositioning the machine; the MONO BOOM – can work in only 9 ft. 7 in.; the SWING BOOM – with generous swing angles (left 80°, right 45°).
NOTE: Available on select models.
- 7 CASE's Easy Maintenance System (EMS) bushing technology** provides longer grease retention, increased lubrication intervals and reduced noise. In addition, our Easy Service Access score resulted in a 40% improvement on the SAE Serviceability index!
- 8 7% faster cycle time** (compared to previous models) – allows for more material to be moved in a shorter period of time, thereby improving profitability.
- 9** The Dozer Blade has an **increased Below Grade Depth and Height** offering more application versatility. A longer blade provides increased stability when working on slopes and allows to climb on higher piles. In addition, the blade curve redesign prevents mud from building up on the blade frame. Both CX75C SR and CX80C have 13,376 lb. of Drawbar Pull.

Compatible with **many attachments**, including multiple bucket options such as heavy-duty, severe, and high-capacity.

First-in-class Tier 4 Final Engine.

The CX75C SR and CX80C CASE midi-excavators dramatically reduce operating expenses thanks to our unique Tier 4 Final solution – a DOC CEGR (Cooled Exhaust Gas Recirculation) system. This highly efficient setup uses 5% less fuel than previous models. And there's no need to burn fuel or time for regeneration and no need to replace costly filters or DEF fluid like competitive solutions. When combined with features such as auto-idle, idle shutdown and three selectable work modes (auto, heavy and speed priority), the CX75C SR and CX80C offer even greater economy. It's a truly simple, timesaving solution.

Wide Open Spaces.

The cab of C Series midi-excavators has been completely redesigned, meeting ROPS and FOPS Level I safety standards. The interior is 7% wider, giving operators the foot space and elbowroom they want. A four-point fluid mounting system absorbs daily bumps and vibrations, and an enhanced A/C system keeps operators comfortable. Plus, 16% more glass and an optional rearview camera give greater visibility in every direction. To top it off, an easy-to-read, full-color 7" monitor comes standard.

Outstanding Versatility.

With either the mono or center swing boom system (offset optional on CX75C SR), four auxiliary hydraulic control systems, three track options (rubber, rubber insert or steel shoes) and two dipperstick lengths, the CX75C SR and CX80C can be customized for general excavation, sewer and water, residential or commercial construction applications.

www.CaseCE.com

CX80C

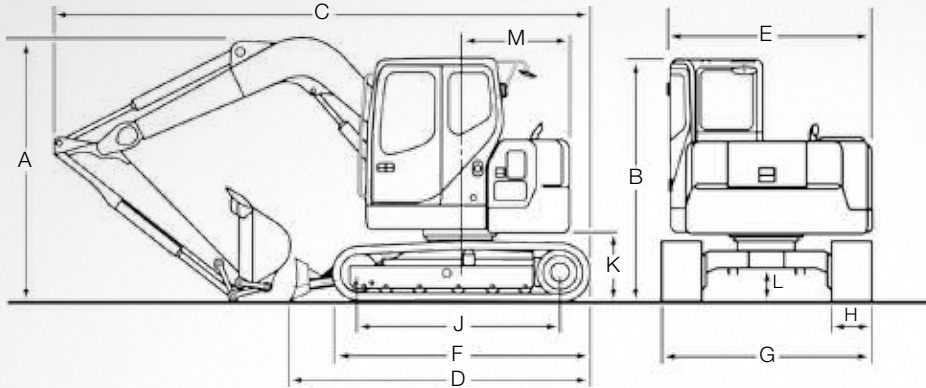

Line drawings are for illustrative purpose only and may not be exact representation of unit.

DIMENSIONS	CX75C SR	CX80C
A. Overall Height – With Attachment	9 ft. 1 in. (2.76 m)	9 ft. 1 in. (2.76 m)
B. Cab Height	9 ft. 1 in. (2.76 m)	9 ft. 1 in. (2.76 m)
C. Overall Length – With Attachment	18 ft. 11 in. (5.76 m)	21 ft. 11 in. (6.68 m)
D. Overall Length – Without Attachment	11 ft. 2 in. (3.41 m)	11 ft. 2 in. (3.41 m)
E. Width Of Upper Structure	7 ft. 5 in. (2.27 m)	7 ft. 5 in. (2.27 m)
F. Track Overall Length	9 ft. 4 in. (2.85 m)	9 ft. 4 in. (2.85 m)
G. Track Overall Width With 17.55 in. (450 mm) Shoes	7 ft. 7 in. (2.32 m)	7 ft. 7 in. (2.32 m)
H. Track Shoe Width	17.7 in. (450 mm)	17.7 in. (450 mm)
J. Center To Center – Idler To Sprocket	7 ft. 3 in. (2.21 m)	7 ft. 3 in. (2.21 m)
K. Upper Structure Ground Clearance	2 ft. 6 in. (0.75 m)	2 ft. 6 in. (0.75 m)
L. Minimum Ground Clearance	1 ft. 2 in. (0.36 m)	1 ft. 2 in. (0.36 m)
M. Rear Tail Swing Radius	4 ft. 3 in. (1.29 m)	5 ft. 6 in. (1.68 m)

SPECIFICATIONS	CX75C SR	CX80C
Engine	Isuzu AP-4LE2X	Isuzu AP-4LE2X
Emissions Certification	Tier 4 Final	Tier 4 Final
Net hp (kW) @ 2000 RPM	53.6 (40)	53.6 (40)
Bucket Digging Force* – lb. (kN)	12,792 (56.9)	12,792 (56.9)
Arm Digging Force – lb. (kN)	8,880 (39.5)	8,880 (39.5)
Maximum Digging Depth	13 ft. 7 in. (4.13 m)	13 ft. 9 in. (4.18 m)
Operating Weight – lb. (kg)	17,416 (7 900)	18,938 (8 590)
Swing Torque – lb.-ft. (N-m)	12,539 (17 000)	12,539 (17 000)
Drawbar Pull – lb. (kN)	13,376 (59.5)	13,376 (59.5)

NOTE: *Digging force based on ISO6015.

Specifications based on standard arm for each machine: CX75C SR & CX80C – 5 ft. 7 in. (1.69 m).

Maintenance Made Easy.

From eye-level fluid gauges to swing-out coolers to a sliding radiator cleaning net and a relocated fuse box, C Series excavators are built to simplify serviceability. Radiators, filters, hydraulics and the engine are all easily accessible from the ground, so routine maintenance can be done in a matter of minutes.

SmartFit™ Bucket Teeth.

CX75C SR/CX80C buckets come standard with the innovative SmartFit bucket tooth system. These heavy-duty, self-sharpening teeth combine exceptional strength and unmatched ease of installation thanks to a hammerless fastener system with reusable locking pins. Available in a full range of styles.



©2014 CNH Industrial America LLC. All rights reserved. CASE is a trademark registered in the United States and many other countries, owned by or licensed to CNH Industrial N.V., its subsidiaries or affiliates. CNH Industrial Capital is a trademark in the United States and many other countries, owned by or licensed to CNH Industrial N.V., its subsidiaries or affiliates. Printed in U.S.A.

Form No. CCE201410CX75CSR_80C



Always read the Operator's Manual before operating any equipment. Inspect equipment before using it, and be sure it is operating properly. Follow the product safety signs and use any safety features provided.

NOTE: All engines meet current EPA emissions regulations.

NOTE: All specifications are stated in accordance with SAE Standards or Recommended Practices, where applicable.



IMPORTANT: CASE Construction Equipment Inc. reserves the right to change these specifications without notice and without incurring any obligation relating to such change. Availability of some models and equipment builds vary according to the country in which the equipment is used. The illustrations and text may include optional equipment and accessories and may not include all standard equipment. Your CASE dealer/distributor will be able to give you details of the products and their specifications available in your area.



CASE construction equipment is biodiesel-friendly.

Courtesy of MachineMarket