

PRELIMINARY

ENGINE

Model	Isuzu AP-4LE2X
Emissions Certification	Tier 4 Final
Fuel	Requires ultra low-sulfur fuel B5 biodiesel tolerant
Type	Water-cooled, 4-cycle, high pressure common rail system. Turbo-charged w/ air-cooled intercooler, DPD system
Cylinders	4-cylinder in-line
Displacement	133 in ³ (2.179 L)
Bore/Stroke	3.35 x 3.78 in (85 x 96 mm)
Fuel injection	Direct injection – electronic
Fuel filter	Replaceable, full flow spin-on cartridge
Air filter	Dry type element w/ warning restriction indicator
Oil filter	Replaceable, full flow spin-on cartridge
Engine gradeability:	
Side-to-side	35°
Fore and aft	35°
Net horsepower – SAE J1349 @ 2000 RPM:	54 hp (40 kW)
Net max. torque – SAE J1349 @ 1800 RPM:	142 lb-ft (193 N·m)
Cooling operating range:	109.4° to -13° F (43° to -25° C)
Oil	Requires low-ash oil CJ-4

DRIVETRAIN

Travel control	Dual stage relief/counter balance design
Brakes	Mechanical disc
Service brakes	SAHR disc – each motor
Two speed travel:	
Forward/Reverse	
Max. high speed	3.2 mph (5.1 kph)
Max. low speed	2.1 mph (3.3 kph)
Automatic downshift	
Drawbar pull	13,376 lb (59.5 kN)
Gradeability	70% – 35° slope

ELECTRICAL

Voltage	24 Volts
Alternator rating	50 amp
Batteries	2 x 12 Volt
Battery reserve capacity	64 Ah/5 hour
Work lights	24 Volt
1 boom	70 watt
1 upper	70 watt

OPERATOR ENVIRONMENT

FOPS Level 1 cab top guard; Pressurized cab; One-touch auto-lock sliding front window; AC/heat/defrost w/ auto climate control; 6 watt interior dome light; Mechanical-suspension cloth seat; Adjustable armrest; Low-effort joystick controls; Controls pre-wired for auxiliary; Blade control lever; AM/FM radio w/ antenna and 2 speakers; Anti-theft start code system; Rubber floor mat; 12-volt electric socket; 24-volt cigarette lighter; External rear view mirrors; Windshield wiper/washer; Cup holder; Storage compartments; Travel alarm w/ cancel switch; One key start and lock-up; Built-in full-color LCD monitor; Safety glass for all windows; Polycarbonate roof hatch and sun shade.

Air conditioner output	13,492 BTU/hr
Heater output	12,897 BTU/hr
Sound level inside cab – ISO6395	73 dBA

ATTACHMENT

Boom	12 ft 8 in (3 870 mm)
Arm	5 ft 7 in (1 710 mm)
Bucket digging force	12,792 lbf (56.9 kN)

OPERATING WEIGHT

Operating weight – std.	17,416 lb (7 900 kg)
w/ shoes	1 ft 6 in (450 mm)
w/ boom	12 ft 4 in (3 750 mm)
w/ arm	5 ft 7 in (1 710 mm)
w/ bucket	463 lb (210 kg)
w/ dozer blade	7 ft 7 in (2 320 mm)
w/ counterweight	2,139 lb (970 kg)
Operating weight – offset	18,254 lb (8 280 kg)

NOTE: w/ operator/full fuel/standard equipment

DOZER BLADE

Blade Width	7 ft 7 in (2 320 mm)
Blade Height	1 ft 6 in (450 mm)
Max. lift above ground	1 ft 5 in (440 mm)
Max. drop below ground	0 ft 11 in (280 mm)

GROUND PRESSURE

@ Standard operating weight: 4.8 psi (0.33 bar) w/ 23.6 in (600 mm) triple semi-grouser shoes

HYDRAULICS

System design	Open center
Main pumps	Two variable displacement/axial piston
Max. rated flow	19.5 gpm (74 L/min)
System pressures:	
Boom, arm and bucket	4,264 psi (294 bar)
Travel circuits	4,264 psi (294 bar)
Swing circuits	3,278 psi (226 bar)

HYDRAULICS (cont.)

Pilot pump	1 x gear design
Max. capacity	4.8 gpm (18 L/min)
Controls	w/ boom/arm holding valve
Right track travel, bucket, boom and arm acceleration.	Four-spool section
Left track travel, bucket, boom and arm acceleration.	Five-spool section
Swing motor	Fixed displacement axial piston
Swing final drive	Planetary gear reduction
Travel motor	Two-speed independent travel/axial piston

HYDRAULIC CYLINDERS

Boom cylinder	One (1)
Cylinder Bore	4.5 in (115 mm)
Cylinder rod diameter	3.0 in (75 mm)
Cylinder stroke	33.5 in (850 mm)
Arm cylinder	One (1)
Cylinder Bore	3.9 in (100 mm)
Cylinder rod diameter	2.6 in (65 mm)
Cylinder stroke	29.7 in (755 mm)
Bucket cylinder	One (1)
Cylinder Bore	3.3 in (85 mm)
Cylinder rod diameter	2.2 in (55 mm)
Cylinder stroke	26.2 in (665 mm)

SERVICE CAPACITIES

Fuel tank	31.7 gal (120.0 L)
Hydraulic system	25.4 gal (96.3 L)
Hydraulic tank	13.5 gal (51.0 L)
Engine oil w/ filter	3.0 gal (11.5 L)
Final drive	0.3 gal (1.1 L)
Cooling system	3.2 gal (12.2 L)

OTHER SPECIFICATIONS

Swing speed	0 – 10.4 RPM
Swing torque	12,539 lb-ft (17 000 N·m)
Swing brake	Mechanical disc
Undercarriage:	
Length	9 ft 4 in (2 850 mm)
Track gauge	6 ft 2 in (1 870 mm)
Carrier rollers	1
Track rollers	5
Shoes – triple grouser	39
Shoe width – std.	1 ft 6 in (450 mm)
Link pitch	6.1 in (154 mm)
Track:	
Chain	Grease lubricated/strutted
Guides	Single
Adjustment	Hydraulic

LIFT CAPACITIES WITH DOZER BLADE ON GROUND

5 ft 7 in (1.69 m) Lift capacities using a 450 lb (204 kg) bucket, 2,138 lb (970 kg) counterweight

Load (Lift Point Height)	5 ft (1.5 m)		10 ft (3 m)		15 ft (4.5 m)		20 ft (6 m)		MAXIMUM REACH		
	END	SIDE	END	SIDE	END	SIDE	END	SIDE	@	END	SIDE
+20 ft (6 m)			3,750 lb (1 701 kg)	3,750 lb (1 701 kg)					12 ft 4 in (3.76 m)	2,700 lb (1 225 kg)	2,700 lb (1 225 kg)
+15 ft (4.5 m)			4,050 lb (1 837 kg)	4,050 lb (1 837 kg)	3,650 lb (1 656 kg)	3,450 lb (1 565 kg)			17 ft 4 in (5.28 m)	2,300 lb (1 043 kg)	2,300 lb (1 043 kg)
+10 ft (3 m)	8,300 lb (3 765 kg)	8,300 lb (3 765 kg)	5,500 lb (2 495 kg)	5,500 lb (2 495 kg)	4,150 lb (1 882 kg)	3,300 lb (1 497 kg)			19 ft 7 in (5.97 m)	2,250 lb (1 021 kg)	2,050 lb (930 kg)
+5 ft (1.5 m)			7,350 lb (3 334 kg)	5,950 lb (2 699 kg)	4,850 lb (2 200 kg)	3,100 lb (1 406 kg)	2,950 lb (1 338 kg)	1,900 lb (862 kg)	20 ft 2 in (6.15 m)	2,400 lb (1 089 kg)	1,900 lb (862 kg)
Groundline			8,000 lb (3 629 kg)	5,550 lb (2 517 kg)	5,050 lb (2 291 kg)	2,950 lb (1 338 kg)			19 ft 5 in (5.92 m)	2,750 lb (1 247 kg)	1,950 lb (885 kg)
-5 ft (-1.5 m)	8,250 lb (3 742 kg)	8,250 lb (3 742 kg)	7,450 lb (3 379 kg)	5,450 lb (2 472 kg)	4,700 lb (2 132 kg)	2,900 lb (1 315 kg)			17 ft 1 in (5.21 m)	3,600 lb (1 633 kg)	2,400 lb (1 089 kg)
-10 ft (-3 m)	8,600 lb (3 901 kg)	8,600 lb (3 901 kg)	5,150 lb (2 336 kg)	5,150 lb (2 336 kg)					12 ft 9 in (3.89 m)	3,400 lb (1 542 kg)	3,400 lb (1 542 kg)

7 ft 2 in (2.19 m) Lift capacities using a 400 lb (181 kg) bucket, 2,138 lb (970 kg) counterweight

Load (Lift Point Height)	0 ft (0 m)		5 ft (1.5 m)		10 ft (3 m)		15 ft (4.5 m)		20 ft (6 m)		MAXIMUM REACH			
	END	SIDE	END	SIDE	END	SIDE	END	SIDE	END	SIDE	@	END	SIDE	
+20 ft (6 m)					2,350 lb (1 066 kg)	2,350 lb (1 066 kg)						15 ft 0 in (4.57 m)	2,300 lb (1 043 kg)	2,300 lb (1 043 kg)
+15 ft (4.5 m)							3,500 lb (1 588 kg)	3,450 lb (1 565 kg)				19 ft 2 in (5.84 m)	2,000 lb (907 kg)	2,000 lb (907 kg)
+10 ft (3 m)					4,400 lb (1 996 kg)	4,400 lb (1 996 kg)	3,800 lb (1 724 kg)	3,400 lb (1 542 kg)	3,200 lb (1 451 kg)	2,050 lb (930 kg)		21 ft 3 in (6.48 m)	1,950 lb (885 kg)	1,800 lb (816 kg)
+5 ft (1.5 m)					6,750 lb (3 062 kg)	6,150 lb (2 790 kg)	4,600 lb (2 087 kg)	3,200 lb (1 451 kg)	3,550 lb (1 610 kg)	1,950 lb (885 kg)		21 ft 9 in (6.63 m)	2,050 lb (930 kg)	1,700 lb (771 kg)
Groundline			4,150 lb (1 882 kg)	4,150 lb (1 882 kg)	7,950 lb (3 606 kg)	5,600 lb (2 540 kg)	5,050 lb (2 291 kg)	3,000 lb (1 361 kg)	3,600 lb (1 633 kg)	1,900 lb (862 kg)		21 ft 0 in (6.40 m)	2,350 lb (1 066 kg)	1,750 lb (794 kg)
-5 ft (-1.5 m)	4,750 lb (2 155 kg)	4,750 lb (2 155 kg)	7,100 lb (3 221 kg)	7,100 lb (3 221 kg)	7,750 lb (3 515 kg)	5,450 lb (2 472 kg)	4,950 lb (2 245 kg)	2,900 lb (1 315 kg)				18 ft 11 in (5.77 m)	2,950 lb (1 338 kg)	2,050 lb (930 kg)
-10 ft (-3 m)			10,950 lb (4 967 kg)	10,950 lb (4 967 kg)	6,150 lb (2 790 kg)	5,500 lb (2 495 kg)	3,400 lb (1 542 kg)	2,900 lb (1 315 kg)				15 ft 0 in (4.57 m)	3,400 lb (1 542 kg)	2,900 lb (1 315 kg)

5 ft 9 in (1.75 m) Offset lift capacities using a 450 lb (204 kg) bucket, 2,138 lb (970 kg) counterweight

Load (Lift Point Height)	5 ft (1.5 m)		10 ft (3 m)		15 ft (4.5 m)		20 ft (6 m)		MAXIMUM REACH		
	END	SIDE	END	SIDE	END	SIDE	END	SIDE	@	END	SIDE
+20 ft (6 m)			3,550 lb (1 610 kg)	3,550 lb (1 610 kg)					12 ft 10 in (3.91 m)	3,350 lb (1 520 kg)	3,350 lb (1 520 kg)
+15 ft (4.5 m)			3,800 lb (1 724 kg)	3,800 lb (1 724 kg)	3,450 lb (1 565 kg)	3,250 lb (1 474 kg)			17 ft 8 in (5.38 m)	2,550 lb (1 157 kg)	2,350 lb (1 066 kg)
+10 ft (3 m)			4,850 lb (2 200 kg)	4,850 lb (2 200 kg)	3,350 lb (1 520 kg)	3,050 lb (1 383 kg)			19 ft 11 in (6.07 m)	1,900 lb (862 kg)	1,700 lb (771 kg)
+5 ft (1.5 m)			5,950 lb (2 699 kg)	5,250 lb (2 381 kg)	3,050 lb (1 383 kg)	2,700 lb (1 225 kg)	1,800 lb (816 kg)	1,600 lb (726 kg)	20 ft 6 in (6.25 m)	1,700 lb (771 kg)	1,500 lb (680 kg)
Groundline			5,250 lb (2 381 kg)	4,600 lb (2 087 kg)	2,750 lb (1 247 kg)	2,450 lb (1 111 kg)			19 ft 8 in (5.99 m)	1,750 lb (794 kg)	1,550 lb (703 kg)
-5 ft (-1.5 m)	7,500 lb (3 402 kg)	7,500 lb (3 402 kg)	5,200 lb (2 359 kg)	4,500 lb (2 041 kg)	2,650 lb (1 202 kg)	2,350 lb (1 066 kg)			17 ft 5 in (5.31 m)	2,100 lb (953 kg)	1,900 lb (862 kg)
-10 ft (-3 m)	7,750 lb (3 515 kg)	7,750 lb (3 515 kg)	4,800 lb (2 177 kg)	4,650 lb (2 109 kg)					13 ft 2 in (4.01 m)	3,200 lb (1 451 kg)	3,050 lb (1 383 kg)

LIFT CAPACITIES WITH DOZER BLADE OFF GROUND

5 ft 7 in (1.69 m) Lift capacities using a 450 lb (204 kg) bucket, 2,138 lb (970 kg) counterweight

Load (Lift Point Height)	5 ft (1.5 m)		10 ft (3 m)		15 ft (4.5 m)		20 ft (6 m)		MAXIMUM REACH		
	END	SIDE	END	SIDE	END	SIDE	END	SIDE	@	END	SIDE
+20 ft (6 m)			3,750 lb (1 701 kg)	3,750 lb (1 701 kg)					12 ft 4 in (3.76 m)	2,700 lb (1 225 kg)	2,700 lb (1 225 kg)
+15 ft (4.5 m)			4,050 lb (1 837 kg)	4,050 lb (1 837 kg)	3,600 lb (1 633 kg)	3,300 lb (1 497 kg)			17 ft 4 in (5.28 m)	2,300 lb (1 043 kg)	2,300 lb (1 043 kg)
+10 ft (3 m)	8,300 lb (3 765 kg)	8,300 lb (3 765 kg)	5,500 lb (2 495 kg)	5,500 lb (2 495 kg)	3,500 lb (1 588 kg)	3,150 lb (1 429 kg)			19 ft 7 in (5.97 m)	2,150 lb (975 kg)	1,950 lb (885 kg)
+5 ft (1.5 m)			6,400 lb (2 903 kg)	5,700 lb (2 585 kg)	3,250 lb (1 474 kg)	2,950 lb (1 338 kg)	2,000 lb (907 kg)	1,850 lb (839 kg)	20 ft 2 in (6.15 m)	1,950 lb (885 kg)	1,800 lb (816 kg)
Groundline			5,950 lb (2 699 kg)	5,250 lb (2 381 kg)	3,100 lb (1 406 kg)	2,800 lb (1 270 kg)			19 ft 5 in (5.92 m)	2,050 lb (930 kg)	1,850 lb (839 kg)
-5 ft (-1.5 m)	8,250 lb (3 742 kg)	8,250 lb (3 742 kg)	5,850 lb (2 654 kg)	5,200 lb (2 359 kg)	3,050 lb (1 383 kg)	2,750 lb (1 247 kg)			17 ft 1 in (5.21 m)	2,500 lb (1 134 kg)	2,300 lb (1 043 kg)
-10 ft (-3 m)	8,600 lb (3 901 kg)	8,600 lb (3 901 kg)	5,150 lb (2 336 kg)	5,150 lb (2 336 kg)					12 ft 9 in (3.89 m)	3,400 lb (1 542 kg)	3,400 lb (1 542 kg)

7 ft 2 in (2.19 m) Lift capacities using a 400 lb (181 kg) bucket, 2,138 lb (970 kg) counterweight

Load (Lift Point Height)	0 ft (0 m)		5 ft (1.5 m)		10 ft (3 m)		15 ft (4.5 m)		20 ft (6 m)		MAXIMUM REACH			
	END	SIDE	END	SIDE	END	SIDE	END	SIDE	END	SIDE	@	END	SIDE	
+20 ft (6 m)					2,350 lb (1 066 kg)	2,350 lb (1 066 kg)						15 ft 0 in (4.57 m)	2,300 lb (1 043 kg)	2,300 lb (1 043 kg)
+15 ft (4.5 m)							3,500 lb (1 588 kg)	3,350 lb (1 520 kg)				19 ft 2 in (5.84 m)	2,000 lb (907 kg)	2,000 lb (907 kg)
+10 ft (3 m)					4,400 lb (1 996 kg)	4,400 lb (1 996 kg)	3,550 lb (1 610 kg)	3,250 lb (1 474 kg)	2,150 lb (975 kg)	1,950 lb (885 kg)		21 ft 3 in (6.48 m)	1,900 lb (862 kg)	1,750 lb (794 kg)
+5 ft (1.5 m)					6,500 lb (2 948 kg)	5,850 lb (2 654 kg)	3,350 lb (1 520 kg)	3,050 lb (1 383 kg)	2,050 lb (930 kg)	1,850 lb (839 kg)		21 ft 9 in (6.63 m)	1,750 lb (794 kg)	1,600 lb (726 kg)
Groundline			4,150 lb (1 882 kg)	4,150 lb (1 882 kg)	6,000 lb (2 722 kg)	5,350 lb (2 427 kg)	3,150 lb (1 429 kg)	2,850 lb (1 293 kg)	1,950 lb (885 kg)	1,800 lb (816 kg)		21 ft 0 in (6.40 m)	1,800 lb (816 kg)	1,650 lb (748 kg)
-5 ft (-1.5 m)	4,750 lb (2 155 kg)	4,750 lb (2 155 kg)	7,100 lb (3 221 kg)	7,100 lb (3 221 kg)	5,850 lb (2 654 kg)	5,150 lb (2 336 kg)	3,050 lb (1 383 kg)	2,750 lb (1 247 kg)				18 ft 11 in (5.77 m)	2,150 lb (975 kg)	1,950 lb (885 kg)
-10 ft (-3 m)			10,950 lb (4 967 kg)	10,950 lb (4 967 kg)	5,900 lb (2 676 kg)	5,250 lb (2 381 kg)	3,100 lb (1 406 kg)	2,800 lb (1 270 kg)				15 ft 0 in (4.57 m)	3,100 lb (1 406 kg)	2,800 lb (1 270 kg)

5 ft 9 in (1.75 m) Offset lift capacities using a 450 lb (204 kg) bucket, 2,138 lb (970 kg) counterweight

Load (Lift Point Height)	5 ft (1.5 m)		10 ft (3 m)		15 ft (4.5 m)		20 ft (6 m)		MAXIMUM REACH		
	END	SIDE	END	SIDE	END	SIDE	END	SIDE	@	END	SIDE
+20 ft (6 m)			3,550 lb (1 610 kg)	3,550 lb (1 610 kg)					12 ft 10 in (3.91 m)	3,350 lb (1 520 kg)	3,350 lb (1 520 kg)
+15 ft (4.5 m)			3,800 lb (1 724 kg)	3,800 lb (1 724 kg)	3,450 lb (1 565 kg)	3,350 lb (1 520 kg)			17 ft 8 in (5.38 m)	3,150 lb (1 429 kg)	2,450 lb (1 111 kg)
+10 ft (3 m)			4,850 lb (2 200 kg)	4,850 lb (2 200 kg)	3,750 lb (1 701 kg)	3,200 lb (1 451 kg)			19 ft 11 in (6.07 m)	3,150 lb (1 429 kg)	1,800 lb (816 kg)
+5 ft (1.5 m)			6,450 lb (2 926 kg)	5,500 lb (2 495 kg)	4,400 lb (1 996 kg)	2,850 lb (1 293 kg)	3,250 lb (1 474 kg)	1,700 lb (771 kg)	20 ft 6 in (6.25 m)	3,200 lb (1 451 kg)	1,600 lb (726 kg)
Groundline			7,200 lb (3 266 kg)	4,850 lb (2 200 kg)	4,550 lb (2 064 kg)	2,600 lb (1 179 kg)			19 ft 8 in (5.99 m)	3,250 lb (1 474 kg)	1,650 lb (748 kg)
-5 ft (-1.5 m)	7,500 lb (3 402 kg)	7,500 lb (3 402 kg)	6,700 lb (3 039 kg)	4,800 lb (2 177 kg)	4,250 lb (1 928 kg)	2,500 lb (1 134 kg)			17 ft 5 in (5.31 m)	3,250 lb (1 474 kg)	2,000 lb (907 kg)
-10 ft (-3 m)	7,750 lb (3 515 kg)	7,750 lb (3 515 kg)	4,800 lb (2 177 kg)	4,800 lb (2 177 kg)					13 ft 2 in (4.01 m)	3,200 lb (1 451 kg)	3,200 lb (1 451 kg)

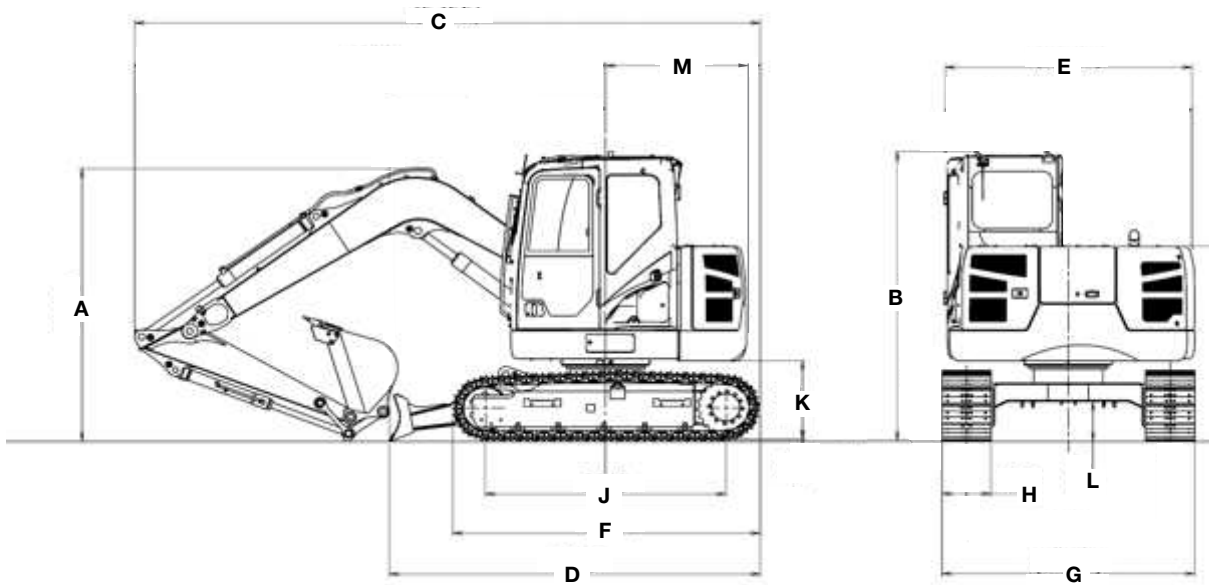

Line drawings are for illustrative purpose only and may not be exact representation of unit.

DIMENSIONS

	5 ft 7 in (1.69 m) Arm	7 ft 2 in (2.19 m) Arm	5 ft 9 in (1.75 m) Arm
A. Overall height – with attachment	9 ft 1 in (2 760 mm)	9 ft 5 in (2 860 mm)	9 ft 9 in (2 970 mm)
B. Cab height	9 ft 1 in (2 760 mm)	9 ft 1 in (2 760 mm)	9 ft 1 in (2 760 mm)
C. Overall length – with attachment	18 ft 11 in (5 760 mm)	20 ft 10 in (6 340 mm)	19 ft 6 in (5 950 mm)
D. Overall length – without attachment	11 ft 2 in (3 410 mm)	11 ft 2 in (3 410 mm)	11 ft 2 in (3 410 mm)
E. Width of upper structure	7 ft 5 in (2 270 mm)	7 ft 5 in (2 270 mm)	7 ft 5 in (2 270 mm)
F. Track overall length	9 ft 4 in (2 850 mm)	9 ft 4 in (2 850 mm)	9 ft 4 in (2 850 mm)
G. Track overall width with 17.55 in (450 mm) shoes	7 ft 7 in (2 320 mm)	7 ft 7 in (2 320 mm)	7 ft 7 in (2 320 mm)
H. Track shoe width	1 ft 6 in (450 mm)	1 ft 6 in (450 mm)	1 ft 6 in (450 mm)
Track gauge	6 ft 2 in (1 870 mm)	6 ft 2 in (1 870 mm)	6 ft 2 in (1 870 mm)
J. Center to center – idler to sprocket	7 ft 3 in (2 210 mm)	7 ft 3 in (2 210 mm)	7 ft 3 in (2 210 mm)
K. Upper structure ground clearance	2 ft 6 in (750 mm)	2 ft 6 in (750 mm)	2 ft 6 in (750 mm)
L. Minimum ground clearance	1 ft 2 in (360 mm)	1 ft 2 in (360 mm)	1 ft 2 in (360 mm)
M. Rear tail swing radius	4 ft 3 in (1 290 mm)	4 ft 3 in (1 290 mm)	4 ft 3 in (1 290 mm)
Dozer blade width	7 ft 7 in (2 320 mm)	7 ft 7 in (2 320 mm)	7 ft 7 in (2 320 mm)
Dozer blade height	1 ft 6 in (450 mm)	1 ft 6 in (450 mm)	1 ft 6 in (450 mm)
Operating weight*	17,416 lb (7 900 kg)	17,494 lb (7 935 kg)	18,254 lb (8 280 kg)
Ground pressure	4.8 psi (0.33 bar)	4.8 psi (0.33 bar)	5.4 psi (0.37 bar)

NOTE: *With 1 ft 6 in (0.45 m) track shoe, 460 lb (210 kg) bucket, 165 lb (75 kg) operator, full fuel and standard equipment.

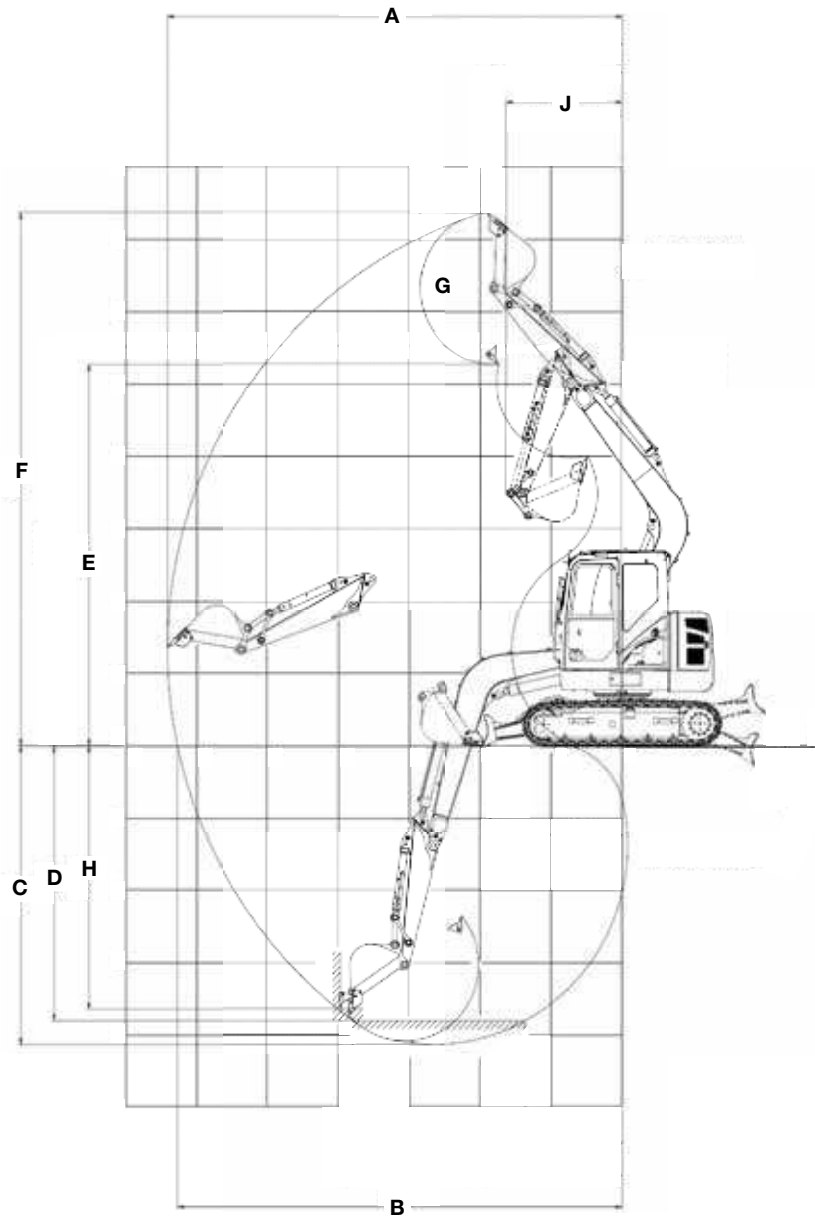

Line drawings are for illustrative purpose only and may not be exact representation of unit.

PERFORMANCE SPECS

	5 ft 7 in (1.69 m) Arm	7 ft 2 in (2.19 m) Arm	5 ft 9 in (1.75 m) Arm
A. Maximum dig radius	21 ft 0 in (6 410 mm)	22 ft 7 in (6 890 mm)	21 ft 4 in (6 500 mm)
B. Dig radius at groundline	20 ft 7 in (6 270 mm)	22 ft 2 in (6 760 mm)	20 ft 10 in (6 350 mm)
C. Maximum dig depth	13 ft 7 in (4 130 mm)	15 ft 2 in (4 630 mm)	13 ft 11 in (4 240 mm)
D. Dig depth – 8 ft 0 in (2.44 m) level bottom	12 ft 6 in (3 800 mm)	14 ft 4 in (4 360 mm)	12 ft 8 in (3 870 mm)
E. Dump height	17 ft 4 in (5 280 mm)	18 ft 7 in (5 670 mm)	17 ft 5 in (5 310 mm)
F. Maximum reach height	24 ft 2 in (7 370 mm)	25 ft 6 in (7 770 mm)	24 ft 3 in (7 380 mm)
G. Bucket rotation	177°	177°	177°
H. Maximum vertical straight wall dig depth	11 ft 11 in (3 640 mm)	13 ft 9 in (4 200 mm)	10 ft 11 in (3 330 mm)
J. Minimum swing radius	5 ft 4 in (1 630 mm)	6 ft 6 in (1 970 mm)	7 ft 0 in (2 130 mm)
Arm digging force	8,880 lb (39.5 kN)	7,599 lb (33.8 kN)	8,858 lb (39.4 kN)
Bucket digging force*	12,792 lb (56.9 kN)	12,792 lb (56.9 kN)	12,792 lb (56.9 kN)
Dozer blade cutting edge:			
Maximum height	1 ft 5 in (440 mm)	1 ft 5 in (440 mm)	1 ft 5 in (440 mm)
Maximum depth	11 in (280 mm)	11 in (280 mm)	11 in (280 mm)

NOTE: *Digging force ratings based on ISO6015.

STANDARD EQUIPMENT

OPERATOR ENVIRONMENT

See page 1

ENGINE

Isuzu four-cylinder turbo-charged diesel
Certified Tier 4 Final
Electronic fuel injection
Neutral safety start
Auto-engine warm up
Glow-plug pre-heat
One-touch idle
Dual-stage fuel filtration
Dual element air filter
Remote oil filter
Green plug oil drain
500-hour engine oil change interval
24-volt system
Color LCD monitor

HYDRAULICS

ISO pattern controls
5,000 hour hydraulic oil change interval
1,000 hour hydraulic filter change interval
SAHR brake
Three (3) work mode settings

UPPER STRUCTURE

Right and left side mirrors
Isolation mounted cab – fluid
Common key vandal locks
Upper mounted work light – 70 watt
Cab mounted work light - 70 watt
Swivel guard belly pan

UNDERCARRIAGE

1 ft 6 in (0.45 m) steel shoes, triple semi-grouser
Full overlap turntable bearing tub
Front track chain guides
Hydraulic track adjustment
X-pattern carbody

FRONT BLADE

Hydraulically controlled front blade:
7 ft 7 in (2.31 m) width
1 ft 6 in (0.45 m) height

ATTACHMENT

Standard boom and arm:
Boom – 12 ft 8 in (3.87 m)
Arm – 5 ft 7 in (1.69 m)
Offset boom and arm:
Boom – 12 ft 10 in (3.92 m)
Arm – 5 ft 9 in (1.75 m)
Boom mounted work light – 70 watt
Attachment cushion valve

OPTIONAL EQUIPMENT

OPERATOR ENVIRONMENT

Control pattern selector
FOPS cab top guard – Level 2
Front grill guard – 2 x 2 screen mesh
Front rock guard:
Vertical bars – fixed/one piece/OPG 2

HYDRAULICS

Auxiliary hydraulics
Single acting
Double acting
Standard boom only:
Double acting bi-directional
Proportional controls

UNDERCARRIAGE

23.6 in (600 mm) steel shoes,
triple semi-grouser*
1 ft 6 in (0.45 m) rubber pads bolted to
standard rail

* Note: blade will not fully cover 23.6" shoe

ATTACHMENT

Arm for std. boom – 6 ft 11 in (2.12 m)
Coupler/Case multi-pin grabber
Heavy-duty bucket



NOTE: All specifications are stated in accordance with SAE Standards or Recommended Practices, where applicable.

NOTE: All engines meet current EPA emissions requirements.

IMPORTANT: Case Construction Inc. reserves the right to change these specifications without notice and without incurring any obligation relating to such change. Case Construction Inc. does not warrant the safety or reliability of attachments from other manufacturers.

CASE is a trademark registered in the United States and many other countries, owned by or licensed to CNH Industrial N.V., its subsidiaries or affiliates. CNH Industrial Capital is a trademark in the United States and many other countries, owned by or licensed to CNH Industrial N.V., its subsidiaries or affiliates.

Form No. CCE201408CX75CDB
Replaces Form No. CCE201302CX75C

Printed in U.S.A.
CX75C • Page 6 of 6

© 2014 CNH Industrial America LLC
All Rights Reserved

 All Case construction equipment is biodiesel ready.



www.casece.com

Courtesy of MachineMarket