

**SKID STEER LOADERS  
COMPACT TRACK LOADERS**

**SR130 | SR160 | SR175 | SV185 | SR210 | SR240 | SR250  
SV280 | SV300 | TR270 | TR310 | TR320 | TV380**

**CASE**

**CONSTRUCTION**



**POWER OUTSIDE,  
COMFORT INSIDE**

[www.casece.com](http://www.casece.com)

**EXPERTS FOR THE REAL WORLD  
SINCE 1842**



**CASE EXPERTS FOR THE REAL WORLD  
SINCE 1842**

- 1842** Case was founded.
- 1969** Case begins skid steer loader production with the first model the 1530 Uni-Loader.
- 1995** Case initiated co-branding and supply agreements with several key suppliers for power and application attachments as well as quick couplers.

- 1998** The exclusive Ride control is introduced on loader backhoes and skid steer loaders: another Case first.
- 2011** Case launches brand new series of skid steer and compact track loaders.
- 2015** New Tier 4 Final models further enrich Case skid steer and compact track loaders offering.



**RADIAL AND VERTICAL BOOM**

Extended line up to meet any customer need

To deliver Case specific performance and productivity to an ever wider range of customers, Case Construction Equipment has expanded its skid steer and compact track loader line-up. The revised range includes six radial lift skid steers (SR models), three radial lift compact track loaders (TR models) three vertical lift skid steers (SV models) and one vertical lift compact track loader (TV model).

# CLEAN POWER, MAXIMISED PRODUCTIVITY



Model	Power HP (kW)	Engine	Tier 4 Technology
SR130	49 (36)	ISM N844L-D IDI 2.2L	Stage 3A / Tier 4i CEGR
SR160	60 (45)	ISM N844LT-F IDI 2.2L	Stage 3B / Tier 4F CEGR with DPF and DOC
SR175	67 (50)	ISM N844LTA-DI-F 2.2L (HPCR)	Stage 3B / Tier 4F CEGR with DOC
SV185	60 (45)	ISM N844LTA-DI-F 2.2L (HPCR)	Stage 3B / Tier 4F CEGR with DOC
SR210	74 (55)	FPT F5H HPCR 3.4L	Stage 3B / Tier 4F PM Catalyst
SR240	74 (55)	FPT F5H HPCR 3.4L	Stage 3B / Tier 4F PM Catalyst
SR250	90 (67)	FPT F5H HPCR 3.4L	Stage 3B / Tier 4i CEGR with DPF and DOC
SV280	74 (55)	FPT F5H HPCR 3.4L	Stage 3B / Tier 4F PM Catalyst
SV300	90 (67)	FPT F5H HPCR 3.4L	Stage 3B / Tier 4i CEGR with DPF and DOC
TR270	74 (55)	FPT F5H HPCR 3.4L	Stage 3B / Tier 4F PM Catalyst
TR310	74 (55)	FPT F5H HPCR 3.4L	Stage 3B / Tier 4F PM Catalyst
TR320	90 (67)	FPT F5H HPCR 3.4L	Stage 3B / Tier 4i CEGR with DPF and DOC
TV380	90 (67)	FPT F5H HPCR 3.4L	Stage 3B / Tier 4i CEGR with DPF and DOC



## LOW EMISSIONS

### Low-to-no-maintenance T4 technology

The electronic engine control enhances precision and responsiveness to operator commands.

Skids **SR175, SV185, SR210, SR240, SR250, SV280, SV300** and Compact Track Loaders **TR270, TR310, TR320** and **TV380** are equipped with High Pressure Common Rail (HPCR) technology, which regulates fuel pressure and injection timing ensuring extremely high injection precision in all engine operating conditions. This results in more torque output and allows to get more useful power from every drop of fuel.

- **Diesel PM** (particulate matter) **Catalyst** traps the residual particulate contained in the exhaust gas of the engine.
- **Cooled Exhaust Gas Recirculation (CEGR)** process is now controlled electronically to achieve greater performance and fuel efficiency, as well as even greater reliability - for example, to help protect the engine from overheating.
- **Diesel Oxidation Catalyst (DOC)** utilizes a chemical process in order to break down pollutants from diesel engines in the exhaust stream, turning them into less harmful components. DOC does not require regeneration and it is a maintenance-free component.
- **Diesel Particulate Filter (DPF)** physically traps particulate matter from the engine exhaust. Electronic controls will trigger an automatic regeneration of the DPF system. Additionally, the system can notify the machine operator to manually regenerate the DPF system occasionally when the soot load in the DPF exceeds the range defined for automatic regeneration.

# POWER OUTSIDE, COMFORT INSIDE



Chassis supports pushing power!



## OUTSTANDING STABILITY

with case power stance chassis

Our power stance chassis rides on a 21 percent longer wheelbase, delivering greater stability and comfort and allowing increased lifting capabilities, regardless of jobsite conditions.



## TOP RANKING BREAKOUT FORCE

Case cylinder and chassis design provides maximised pushing power

The cylinder geometry optimises the skid steer and compact track loader's push and pull power, while the bucket support baring directly on the chassis of the machine further adds to its pushing power.

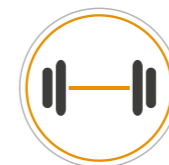

## CUSTOMIZABLE ROC

with bolt-on counterweights

Simply bolt on **additional counterweights** to the rear sides of the machine. **Increase ROC** by adding counterweights to move more material, more quickly **Decrease ROC** (operating without counterweights to keep fuel costs down and decrease ground disturbance.

# THE MOST COMFORTABLE CAB EVER

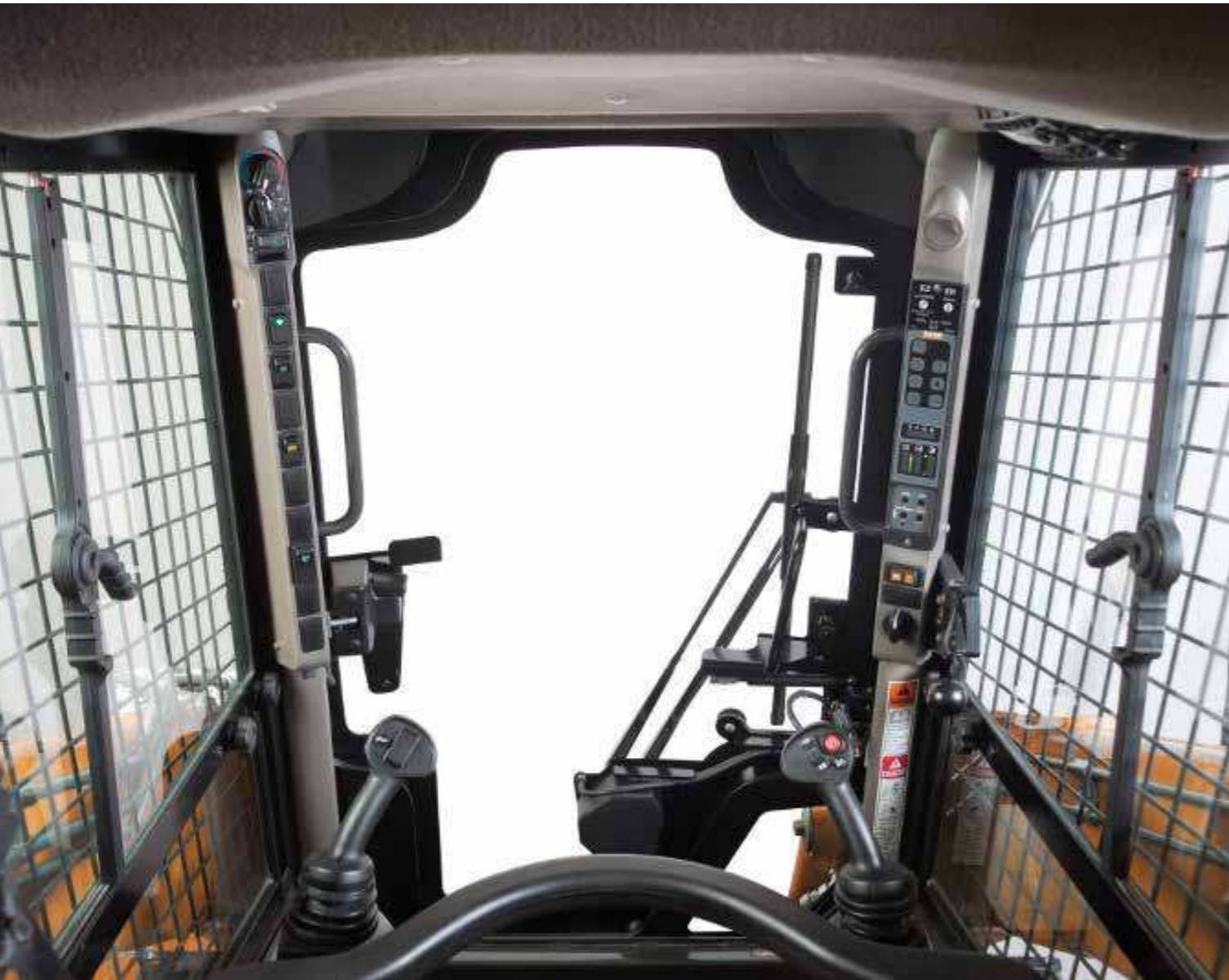

## OUTSTANDING VISIBILITY

Wider glazed surface for safer operations

The large glazed surface with ultra-narrow wire side screens, the lowered threshold and thinner front pillars provide the best visibility in the market (ROPS / FOPS cab).



## EASY CAB ACCESS

Safety first

Low threshold, together with convenient grab handles make accessing the cab easy and safe.



## COMFORTABLE AND SAFE CAB

Leading operator comfort

The wide door, repositioned grab handles and a lower threshold provide easy access to the cab. All models have suspension seats and optional air suspension heated seats for the ultimate in comfort. If specified with full cab glazing and door, the cab is completely sealed to reduce the amount of noise and dust.

25% wider cab

It's not just the range that has expanded: all models benefit from a cab with up to 25% more internal width, providing greatly improved operator comfort. Our cab - the widest in the industry - provides plenty of room for comfortable operation, with greater headroom and legroom, more space between the control levers and easy access to the seat.



## AUTO RIDE CONTROL™

Optimised shock absorption

Comfort goes with productivity with CASE patented Ride Control. This optional feature is a shock absorber which reduces loader arm bouncing at elevated speed for greater material retention and increased operator comfort. More material moved, more quickly.



# CONTROL EVERYTHING WITH TWO FINGERS



## VERSATILE CONTROLS

### Tailor-made performance

The upgraded Case skids now offer EZ-EH (electro-hydraulic) controls and software. Operators can quickly change between nine presets for speed and control customization.

## FREE TO CHOOSE THE MOST SUITABLE CONTROL

### Mechanical or Electro Hydraulic controls

All controls are within easy reach and you can choose among mechanical hand drive levers or mechanical foot drive pedals, or electro-hydraulic controls.

### Proportional auxiliary hydraulics

Standard Proportional control of Auxiliary Hydraulics with detent for smooth and precise attachment control.



## HIGH VERSATILITY

### Hydraulics simplified. Versatility maximised

Connect Under Pressure (CUP) system to plug hydraulic hoses with no wrenches. Three different Auxiliary Hydraulics Packages offered:

### (1) Standard Flow Package

- The standard system operates the majority of available hydraulic attachments
- The proportional control provides a precise control of the attachment

### (2) High Flow Package

- Up to 55% more flow with the high-flow auxiliary hydraulics option (package level 4 and 5)
- High flow is required for attachments such as cold planers, rock wheels or large hammers
- Packages level 4 and 5 include a 14-pin front electric system to handle multiple movements of the attachment directly from the joysticks

### (3) Enhanced High Flow Package

- The enhanced high flow option (package level 7) is designed for extreme applications, such as large cold planers and mulchers



# MAIN REASONS TO CHOOSE IT



## LOW EMISSIONS

- Low-to-no maintenance Stage 3B Tier 4 technology

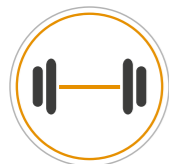

## CUSTOMIZABLE ROC

- Additional counterweights



## SIMPLE AND ROBUST UNDERCARRIAGE

- Robust fixed undercarriage
- Few moving parts
- Self-lubricated rollers



## HIGH VERSATILITY

- Wide range of attachments
- Different auxiliary hydraulic solutions to feed them.



## FAST ATTACHMENT CHANGE OVER

- Mechanic or hydraulic quick coupler
- Connect Under Pressure (CUP) system to plug hydraulic hoses with no wrenches



## RADIAL AND VERTICAL BOOM

- Radial for digging and pushing
- Vertical for loading and carrying



## COMFORTABLE AND SAFE CAB

- Wide cab, flat floor, convenient lap bar, optimized A/C air flow
- ROPS, FOPS certified
- Suspension and heated seats



## OUTSTANDING VISIBILITY

- Unique side lightening
- Large side windows for an excellent visibility
- Better sight lines to the tires, bucket edge, curb lines and even to the rear when backing up.



## EASY CAB ACCESS

- Wider cab entrance
- Lower threshold
- Longer and ergonomic handles



## VERSATILE CONTROLS

- Mechanical or EH customizable controls
- Speed and sensitivity can easily be adjusted
- ISO-H switchable controls
- Ride Control for a greater operator comfort



## OUTSTANDING STABILITY

- Longer wheelbase
- Optimized weight distribution



## TOP RANKING BREAKOUT FORCE

- Aggressive cylinder mounting for superior digging efficiency





**SIMPLE AND ROBUST UNDERCARRIAGE**

to ensure long-lasting operativity

The new Case compact track loaders feature a robust undercarriage, engineered to hold fast on steep slopes and take command of muddy or sandy terrain. The undercarriage has a rigid-track frame with fewer moving parts for greater durability and easier maintenance than suspension-track systems.

**Heavy-duty drive motor/final drive**

Increases component life by using an oversized bearing in line with the drive sprocket and elevating the drive assembly, keeping it out of material.



**Lifetime sealed and oil lubricated rollers and idlers**

Duo-cone face seals utilize proven dozer oil-lubrication technology that provides greater reliability and lower maintenance costs. The seals reduce the possibility of material and moisture getting into the rollers and idlers.



**Simple hydraulic track adjustment**

Track tension is simply adjusted by adding or removing grease to a hydraulic cylinder. Track tension is important to undercarriage life and track life.



**Triple flange rollers**

Helps prevent de-tracking on inclines by using dozer-style rollers with a larger inner-diameter flange positioned between the track lugs.



# MAINTENANCE MADE EASY AND RATIONAL



## SAFE AND EASY MAINTENANCE

### Convenient cab tilting

With just two retaining bolts, the cab is easy to tilt, providing access to hydraulic and transmission components when necessary.

A safety locking system that prevents the cab from dropping is automatically activated.

### Best-in-class serviceability

Easy access, daily service points grouped together and remote mounted filters mean it's easy to keep Case skid steer and compact track loaders working to their maximum efficiency.



Maintenance kept easy even with the most advanced T4 engine technology



**Smart battery and drain hoses access**  
Battery and environmental drain hoses are easily accessible from the side of the machine, by removing a tap located behind the rear wheel, allowing quick service and fast maintenance activities.

# TYRES AND TELEMATICS



## THE SCIENCE BIT

The Case SiteWatch telematics system uses a high-tech control unit mounted on each machine to collate information from that machine and from GPS satellites. This data is then sent wirelessly through the mobile communication networks to the Case Telematics Web Portal.

### SiteWatch: centralised fleet control benefits at your fingertips

- 📶 Measure your true asset availability and optimise it
- 📶 Challenge your Total Cost of Ownership!
- 📶 More Safety, Lower Insurance Premium



FUNCTIONAL VARIANTE	DESCRIPTION	SR130	SR160	SR175	SV185	SR210	SR240	SR250	SV280	SV300
8501207	10X16.5 Heavy Duty 590TW	x	x							
8501307	10X16.5 Premium 590TW	x	x							
8501407	10X16.5 Premium Liner 590TW	x	x							
8501507	27X10.5-15 Premium 640TW	x	x							
8502107	10X16.5 Non-Pneumatic 640TW	x	x	x	x	x				
8501707	10X16.5 Heavy Duty 640TW			x	x	x				
8501807	10X16.5 Premium 640TW			x	x	x				
8501907	10X16.5 Premium Liner 640TW			x	x	x				
8502007	10X16.5 Severe Duty 640TW			x	x	x				
8503107	12X16.5 Heavy Duty 700TW			x	x	x	x	x	x	x
8503207	12X16.5 Premium 700TW			x	x	x	x	x	x	x
8503307	12X16.5 Premium Liner 700TW			x	x	x	x	x	x	x
8503407	12X16.5 Severe Duty 700TW					x	x	x	x	x
8503507	12X16.5 Mining 700TW					x	x	x	x	x
8503607	12X16.5 Non-Pneumatic 700TW					x	x	x	x	x
8505007	33X15.5 Flotation 760TW					x	x	x	x	x
8505107	14X17.5 Premium 760TW						x	x	x	x



HEAVY DUTY      PREMIUM & PREMIUM W/LINER      SEVERE DUTY      NON-PNEUMATIC      MINING      FLOTATION



# VERSATILITY AND EFFECTIVENESS EASILY CONNECTED

# POWER OUTSIDE, COMFORT INSIDE



## HIGH VERSATILITY to undertake any type of job

Case skid steer loaders and compact track loaders can handle a broad range of attachments, providing outstanding versatility to serve a broad range of industries.



## FAST ATTACHMENT CHANGE OVER Handle attachments easily

The Connect Under Pressure standard feature allows you to connect tool hoses without a wrench. With the hydraulic coupler option attachments can be changed rapidly without leaving the cab.



WHEEL EXCAVATOR

WHEEL COMPACTOR

ASPHALT FLOAT

PLANER



PLANER



BROOM BUCKET



INDUSTRIAL BACKHOE



CEMENT MIXER



HAMMER



AUGER



FARM FORK



FORK & GRAPPLE



BALE SPIKE



4X1 MULTIPURPOSE BUCKET



SNOW BLOWER



SNOW BLADE

Attachment	Application	Width (mm)	Depth (mm)	Weight (kg)	Flow	Compatible Model
Wheel Excavator	Trenching jobs on hard, compact materials like asphalt and concrete, digging trenches on roads or in areas where movement is restricted.	Wheel width 130	150 - 450 200 - 600	1.155	High	SR210 and bigger SR175 / SV185 / SR210
		130		1.260		
Wheel Compactor	Compacting the bed of a trench before adding an asphalt surface layer.	Wheel width 200 - 250 - 300 350 - 400	0 - 750	550	Std	SR210 and bigger
Asphalt Float	Backfilling of trenches and widening road surface while maintaining the road's original gradient.	1900	N.A.	620	Std	SR175 and bigger
Planer	Planing on asphalt or concrete. Overlaying road, industrial and courtyard surfaces. Maintenance of stretches of road. Restoration of damaged, bumpy or worn surfaces.	350	0 - 110	590	Std	SR175 and bigger SR175 / SV185 / SR210 SR210 and bigger SR210 and bigger
		450	0 - 150	790	High	
		600	0 - 170	950	High	
		1.000	0 - 130	1.090	High	
Broom Bucket	Clearing yards, roads, footpaths, etc. Also efficient for snow clearance.	1.525		225		SR130 / SR160 SR175 / SV185 / SR210 SR175 / SV185 / SR210 SR250 / SV300 SR250 / SV300
		1.680		278		
		1.850		460		
				522		
		2.080				
Industrial Backhoe	Creation of trenches, foundations, drain and irrigation channels, etc. in private or public constructions, both for new or maintenance jobs.	Bucket width 250 - 600	Digging depth 2480 2780 3260	520	Std	SR130 / SR160 SR175 / SV185 / SR210 SR240 and bigger / All CTLs
		250 - 600		750	High	
		300 - 800		1020	Std	
Cement Mixer	Production of cement for civil construction in isolated or difficult-to-access areas, or with limited availability of electric energy.	150		639	Std	SR150 and bigger SR175 and bigger SR210 and bigger SR240 and bigger SR250 and bigger TV380
		200		794	Std	
		250-250		945-940	Std	
		300		1013-1008	Std	
		350		1188	Std	
		450		1694	Std	
Pallet Fork	Handling of palletized loads.	Forks length 1.000		160		SR210 and smaller SR210 and smaller All
		1.100		164		
		1.200		168		
Hammer	Concrete demolition jobs, trenching and general excavation work.			160	Std	SR130 / SR160 SR130 / SR160 SR175 and bigger SR250 / SV300 SR250 / SV300
				210	Std	
				275	Std	
				370	High	
				505	High	
Auger (std flow) Auger (high flow)	Boring of holes in the ground such as telegraph poles, electricity pylons, signposts, metallic frame pillars, tree and shrub planting	760	1.200	20 - 175	Std	All SR175 and bigger with High Flow
		900	1.200	30 - 225	High	
Farm Fork	General farm yard applications	1.525		153		SR130; SR160 SR175 / SV185 / SR210 SR175 / SV185 / SR210/ SR250 / SV300 SR250 / SV300
		1.680		170		
		1.850		185		
		2.080		242		
Fork & Grapple	"Mucking out" bale and silage handling. Also suitable for industrial applications	1.525		250		SR130; SR160 SR175 / SV185 / SR210 SR175 / SV185 / SR210 SR250 / SV300 SR250 / SV300
		1.680		260		
		1.850		310		
		2.080		380		
Bale Spike	Handling of round bales	980		79		All
High Tip Bucket	Increase dump height by 800 to 1.200 mm	1.525		364		SR130 / SR160 SR175 / SV185 / SR210 SR175 / SV185 / SR210 SR250 / SV300 SR250 / SV300
		1.680		285		
		1.850		352		
		2.080		496		
4X1 Multipurpose Bucket	Applications as conventional bucket, grab for back filling or as a dozer	1.525		253		SR130 / SR160 SR175 / SV185 / SR210 SR175 / SV185 / SR210 SR250 / SV300 SR250 / SV300
		1.680		283		
		1.850		340		
		2.080		435		
Wide range of Buckets (Dirt&Foundry; Low Profile; Low Profile Extended, Heavy Duty, Manure/Slurry; Light Material)	Digging, excavating, grading, material handling	1.525				SR130 / SR160 SR175 / SV185 / SR210 SR175 / SV185 / SR210 SR250 / SV300 SR250 / SV300
		1.680				
		1.830				
		1.850				
		2.080				
Snow Blower	Ideal for effective removal of large quantities of snow without damaging the road surface.	1.800		480	Std/High	SR175 / SV185 / SR210 SR250 / SV300 / TR270 SR210 / SR250 / SV300 TR320 / TV380
		2.100		540	Std/High	
Snow Blade	Ideal for effective removal of large quantities of snow without damaging the road surface.	2.100		315	Std	SR130 / SR160 / SR175 SV185 / SR210 / TR270 SR250 / SV300 / TR320 TV380
					Std	
		2.400		410	Std	

# SKID STEER LOADERS COMPACT TRACK LOADERS

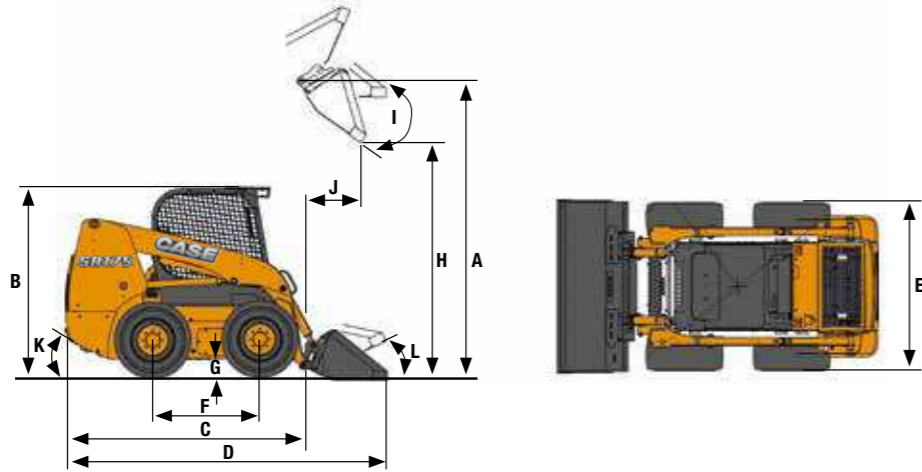

## GENERAL DIMENSIONS

	SR130	SR160	SR175	SV185	SR210	SR240	SR250	SV280	SV300
A - Height to Bucket Hinge Pin	2.845 mm	2.845 mm	3.099 mm	3.048 mm	3.124 mm	3.175 mm	3.175 mm	3.302 mm	3.302 mm
B - Height to Top of ROPS	1.919 mm	1.919 mm	1.974 mm	1.974 mm	1.998 mm	2.002 mm	2.002 mm	2.002 mm	2.002 mm
C - Length without attachment	2.435 mm	2.435 mm	2.685 mm	2.685 mm	2.669 mm	2.981 mm	2.981 mm	2.990 mm	2.990 mm
D - Length with bucket *	3.028 mm	3.028 mm	3.305 mm	3.345 mm	3.292 mm	3.611 mm	3.611 mm	3.604 mm	3.604 mm
E - Overall Width	1.518 mm	1.518 mm	1.678 mm	1.678 mm	1.755 mm	1.768 mm	1.768 mm	1.768 mm	1.768 mm
F - Wheelbase	941 mm	941 mm	1.128 mm	1.128 mm	1.128 mm	1.322 mm	1.322 mm	1.322 mm	1.322 mm
G - Ground Clearance	178 mm	178 mm	178 mm	178 mm	203 mm	203 mm	203 mm	203 mm	203 mm
H - Dump height *	2.246 mm	2.246 mm	2.470 mm	2.380 mm	2.495 mm	2.562 mm	2.562 mm	2.629 mm	2.629 mm
I - Dump Angle	40°	40°	40°	52°	40°	38°	38°	54°	54°
J - Dump Reach @ Max Height	469 mm	469 mm	542 mm	783 mm	517 mm	575 mm	575 mm	744 mm	744 mm
K - Angle of Departure	22°	22°	23°	23°	25°	24°	24°	24°	24°
L - Rollback Angle (Bucket on Ground)	26°	26°	32°	35°	31°	31°	31°	35°	35°

## SPECIFICATIONS

	SR130	SR160	SR175	SV185	SR210	SR240	SR250	SV280	SV300
<b>FRAME SIZE</b>	Small Frame	Small Frame	Medium Frame	Medium Frame	Medium Frame	Large Frame	Large Frame	Large Frame	Large Frame
<b>EMISSIONS LEVEL</b>	Tier 4i / Stage 3A	Tier 4F / Stage 3B	Tier 4F / Stage 3B	Tier 4F / Stage 3B	Tier 4F / Stage 3B	Tier 4F / Stage 3B	Tier 4i / Stage 3B	Tier 4F / Stage 3B	Tier 4i / Stage 3B
<b>PERFORMANCE SPECS</b>									
Rated Operating Capacity 50%	590 kg	725 kg	790 kg	840 kg	905 kg	1.088 kg	1.135 kg	1.270 kg	1.360 kg
ROC with counterweights 50%	635 kg	770 kg	835 kg	885 kg	950 kg	1.178 kg	1.225 kg	1.360 kg	1.450 kg
Tipping Load	1.179 kg	1.455 kg	1.588 kg	1.678 kg	1.814 kg	2.177 kg	2.268 kg	2.540 kg	2.722 kg
Lift Cylinder Breakout Force**	13.0 kN	15.0 kN	17.0 kN	15.3 kN	20.3 kN	25.0 kN	25.3 kN	25.0 kN	24.9 kN
Bucket Cylinder Breakout Force**	19.0 kN	23.4 kN	32.3 kN	24.7 kN	32.3 kN	39.4 kN	33.3 kN	33.7 kN	33.7 kN
<b>ENGINE</b>									
Engine Make - Model	ISM N844L-D (Nat. Asp.)	ISM N844LT-F (Turbo)	ISM N844LTA-DI-F (Turbo)	ISM N844LTA-DI-F (Turbo)	FPT F5H (Turbo)	FPT F5H (Turbo)	FPT F5C (Turbo)	FPT F5H (Turbo)	FPT F5H (Turbo)
Displacement	2.2 l	2.2 l	2.2 l	2.2 l	3.4 l	3.4 l	3.4 l	3.4 l	3.4 l
Horsepower	49 hp @ 2.800 rpm	60 hp @ 2.800 rpm	67 hp @ 2.800 rpm	60 hp @ 2.900 rpm	74 hp @ 2.500rpm	74 hp @ 2.500rpm	90 hp @ 2.500rpm	74 hp @ 2.500rpm	90 hp @ 2.500 rpm
Peak torque	143 Nm @ 1.800 rpm	188 Nm @ 1.800 rpm	208 Nm @ 1.800 rpm	183 Nm @ 1.800 rpm	314 Nm @ 1.400 rpm	314 Nm @ 1.400 rpm	383 Nm @ 1.400 rpm	314 Nm @ 1.400 rpm	383 Nm @ 1.400 rpm
<b>TRAVEL SPEED</b>									
Low Range	12.7 km/h	11.9 km/h	11.9 km/h	11.9 km/h	11.4 km/h	12.4 km/h	11.3 km/h	12.4 km/h	11.3 km/h
High Range (Optional)	NA	NA	18.5 km/h	18.5 km/h	16.9 km/h	18.5 km/h	18.5 km/h	18.5 km/h	18.5 km/h
<b>HYDRAULIC SYSTEM</b>									
Pump flow	59 LPM	70 LPM	78 LPM	78 LPM	92 LPM	92 LPM	92 LPM	92 LPM	92 LPM
Optional high flow	N/A	N/A	116 LPM	116 LPM	126 LPM	143 LPM	143 LPM	143 LPM	143 LPM
Relief Pressure	210 bar	210 bar	210 bar	210 bar	210 bar	210 bar	210 bar	210 bar	210 bar
<b>WEIGHTS</b>									
Operating Weight	2.300 kg	2.505 kg	2.842 kg	2.980 kg	3.160 kg	3.350 kg	3.490 kg	3.670 kg	3.765 kg
Shipping Weight	2.160 kg	2.370 kg	2.705 kg	2.840 kg	3.025 kg	3.200 kg	3.340 kg	3.475 kg	3.610 kg
<b>SERVICE CAPACITY</b>									
Fuel Tank	60.5 l	60.5 l	73.8 l	73.8 l	73.8 l	96.5 l	96.5 l	96.5 l	96.5 l

# POWER OUTSIDE, COMFORT INSIDE

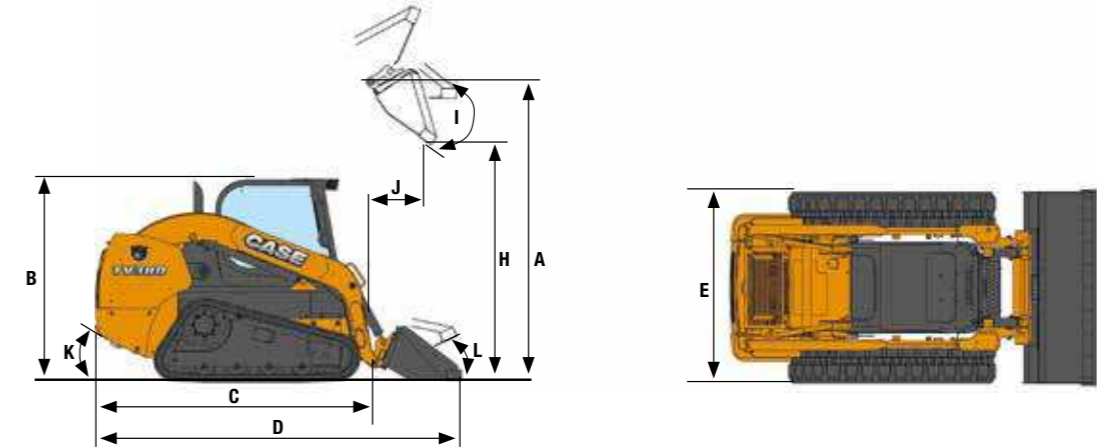

## GENERAL DIMENSIONS

	TR270	TR310	TR320	TV380
A - Height to Bucket Hinge Pin	3.124 mm	3.124 mm	3.215 mm	3.342 mm
B - Height to Top of ROPS	1.998 mm	1.998 mm	2.043 mm	2.043 mm
C - Length without attachment	2.669 mm	2.669 mm	2.981 mm	2.990 mm
D - Length with bucket *	3.292 mm	3.292 mm	3.611 mm	3.604 mm
E - Overall Width	1.676 mm	1.888 mm	1.930 mm	1.930 mm
F - Wheelbase	NA	NA	NA	NA
G - Ground Clearance	203 mm	203 mm	243 mm	243 mm
H - Dump height *	2.495 mm	2.495 mm	2.602 mm	2.669 mm
I - Dump Angle	40°	40°	38°	54°
J - Dump Reach @ Max Height	568 mm	568 mm	548 mm	798 mm
K - Angle of Departure	32°	32°	32°	32°
L - Rollback Angle (Bucket on Ground)	31°	31°	30°	34°

## SPECIFICATIONS

	TR270	TR310	TR320	TV380
<b>FRAME SIZE</b>	Medium Frame	Medium Frame	Large Frame	Large Frame
<b>EMISSIONS LEVEL</b>	Tier 4F / Stage 3B	Tier 4F / Stage 3B	Tier 4i / Stage 3B	Tier 4i / Stage 3B
<b>PERFORMANCE SPECS</b>				
Rated Operating Capacity 50%	50%: 1.225 35%: 860	50%: 1.406 35%: 984	50%: 1.451 35%: 1.018	50%: 1.723 35%: 1.209
ROC with counterweights 50%	50%: 1.280 35%: 915	50%: 1.461 35%: 1.039	50%: 1.676 35%: 1.203	50%: 1.948 35%: 1.394
Tipping Load	2.450 kg	2.810 kg	2.902 kg	3.447 kg
Lift Cylinder Breakout Force**	27.8 kN	29.0 kN	34.5 kN	26.8 kN
Bucket Cylinder Breakout Force**	32.3 kN	38.6 kN	38.7 kN	33.4 kN
<b>ENGINE</b>				
Engine Make - Model	FPT F5H (Turbo)	FPT F5H (Turbo)	FPT F5H (Turbo)	FPT F5H (Turbo)
Displacement	3.4 l	3.4 l	3.4 l	3.4 l
Horsepower	74 hp @ 2.500rpm	74 hp @ 2.500rpm	90 hp @ 2.500 rpm	90 hp @ 2.500 rpm
Peak torque	314 Nm @ 1.400 rpm	314 Nm @ 1.400 rpm	383 Nm @ 1.400 rpm	383 Nm @ 1.400 rpm
<b>TRAVEL SPEED</b>				
Low Range	8.2 km/h	8.2 km/h	8.2 km/h	8.2 km/h
High Range (Optional)	12.2 km/h	12.2 km/h	12.2 km/h	12.2 km/h
<b>HYDRAULIC SYSTEM</b>				
Pump flow	92 LPM	92 LPM	92 LPM	92 LPM
Optional high flow	123 LPM	123 LPM	143 LPM	143 LPM
Relief Pressure	210 bar	210 bar	210 bar	210 bar
<b>WEIGHTS</b>				
Operating Weight	3.750 kg	4.027 kg	4.355 kg	4.625 kg
Shipping Weight	3.615 kg	3.891 kg	4.200 kg	4.475 kg
<b>SERVICE CAPACITY</b>				
Fuel Tank	73.8 l	73.8 l	96.5 l	96.5 l



**CASE CONSTRUCTION EQUIPMENT  
CONTACT INFORMATION**

**CNH UK LTD**

Unit 4,  
Hayfield Lane Business Park,  
Field Lane, Auckley,  
Doncaster, DN9 3FL  
UNITED KINGDOM  
Tel: 00800-2273-7373  
Fax +44 (0) 1302 802829

**CNH INDUSTRIAL ITALIA SPA**

Strada di Settimo, 323  
10099 San Mauro Torinese (TO)  
ITALY - ITALIA  
Tel: 800 2273 7373

**CNH INDUSTRIAL  
DEUTSCHLAND GMBH**

Case Baumaschinen  
Benzstr.1-3  
D-74076 Heilbronn  
GERMANY - DEUTSCHLAND  
Tel: +49 (0) 7131 6449 0  
Fax +49 (0) 7131 6449 181

**CNH INDUSTRIAL  
MAQUINARIA SPAIN, S.A.**

Avda. José Gárate, 11  
28823 Coslada (Madrid)  
SPAIN - ESPAÑA  
Tel: +34 91 660 38 00  
Fax: +34 91 660 38 18

**CNH INDUSTRIAL FRANCE, S.A.**

16-18 Rue des Rochettes  
91150 - Morigny-Champigny  
FRANCE  
Tel: +33 (0) 1 60 80 74 80

NOTE: Standard and optional fittings can vary according to the demands and specific regulations of each country. The illustrations may include optional rather than standard fittings - consult your Case dealer. Furthermore, CNH Industrial reserves the right to modify machine specifications without incurring any obligation relating to such changes.

Conforms to directive 2006/42/EC