

140M/140M AWD 160M/160M AWD



Motor Graders



	140M		140M AWD		160M		160M AWD	
Engine Model	Cat® C7 ACERT™		Cat C9 ACERT		Cat C9 ACERT		Cat C9 ACERT	
Emissions: Engine is Certified for Environment Canada Tier 3 Standards								
Base Power (1st gear) – Net	136 kW	183 hp	159 kW	213 hp	159 kW	213 hp	159 kW	213 hp
VHP Plus Range – Net	136-174 kW	183-233 hp	159-200 kW	213-268 hp	159-185 kW	213-248 hp	159-200 kW	213-268 hp
Moldboard – Width	3.7 m	12 ft	3.7 m	12 ft	3.7 m	12 ft	3.7 m	12 ft
Gross Vehicle Weight – Typically Equipped	18 991 kg	41,868 lb	19 883 kg	43,834 lb	19 715 kg	43,465 lb	20 607 kg	45,432 lb

Features

Operator Station

Industry leading cab design gives you unmatched comfort, visibility and ease of use, so your operators can be more confident and productive.

Structures, Drawbar, Circle and Moldboard

Durable structures with fast and simple DCM adjustments save you service time. Shims and wear strips save you money and make it easy to maintain factory tightness of components for better grading results.

Hydraulics

Load sensing, proportional hydraulics mean operators can rely on consistent power. This precise, predictable implement response will save time and help assure quality work.

Integrated Technologies

Grade control and machine monitoring technologies help you improve grading efficiency and enhance fleet management for improved machine utilization.

Safety

The safety of your operators and those on the job site is key in the design of every Cat machine. Features like outstanding visibility, hydraulic lockout and redundant steering and braking systems help you meet your goals of getting everyone home safely at the end of each work day.

Contents

Operator Station.....	4
Steering and Implement Controls	5
Engine	6
Power Train.....	7
Structures and Drawbar-Circle-Moldboard....	8
Hydraulics	9
All Wheel Drive (AWD).....	10
Integrated Technologies.....	11
Safety	12
Serviceability and Customer Support.....	14
Smart Machine Systems.....	14
Work Tools and Attachments.....	15
Sustainability	16
Specifications.....	17
Standard Equipment.....	26
Optional Equipment.....	27





The M Series Motor Grader has become the industry standard in operational efficiency and overall productivity. From building roads to maintaining them, M Series Motor Graders are designed to help you get more work done in less time. Unprecedented operator comfort and ease of service help to maximize your return on investment.

Operator Station

Comfort, productivity, advanced technology



Visibility

Good visibility is key to your safety and efficiency. Angled cab doors, tapered engine enclosure and a sloped rear window make it easy to see the moldboard and tires, as well as behind the machine. An optional rear vision camera further enhances lines of sight all around the machine.

Comfort and Control

Experience the most spacious, comfortable cab in the industry. Joystick controls replace levers, so hand and arm movement is reduced by 78%, helping reduce operator fatigue for better productivity. Rocker and control switches are in easy reach.

A standard Cat Comfort Series suspension seat is fully adjustable. Control pods can be adjusted electronically so it is even easier to set up for an ideal operating position. Multiple isolation mounts significantly reduce sound and vibration for a more relaxed work environment.

The high capacity Heating, Ventilation and Air Conditioning (HVAC) system dehumidifies and pressurizes the cab, circulates fresh air, seals out dust and keeps windows clear.

An optional deluxe AM/FM radio with CD, MP3 and Bluetooth technology enables streaming audio from a portable device and hands-free use of a mobile phone when safe to do so.

In-Dash Instrument Cluster

Easy-to-read, high-visibility gauges and warning lamps keep you aware of critical system information. Cat Messenger offers real-time machine performance and diagnostic data to help you get the most from your machine.

Steering and Implement Controls

Unprecedented precision and ease of operation



Operators are more comfortable and productive with two electro-hydraulic joysticks. New and experienced operators around the world report that the controls are easy to learn, and that the new electronically adjustable control pods make it easier to position them for optimal comfort, visibility and proper operation.

Joystick Functions

The left joystick controls steering, articulation, return-to-center, wheel lean, gear selection, left moldboard lift cylinder and float.

The right joystick controls drawbar, circle and moldboard functions as well as electronic throttle control and manual differential lock/unlock.

Joystick lean angle mirrors the steer tires' turning angle. A brake tensioning system holds the joystick in position until the operator moves it. The steering control automatically reduces steering sensitivity at higher ground speeds for predictable control. Infinitely variable roller switches control the rear ripper and/or front lift group (when equipped).



Electronic Throttle Control

Electronic Throttle Control helps improve productivity by providing the best match of horsepower and torque for the demands of the application.

Articulation Return-to-Center

Automatically returns the machine to a straight frame position from any angle with the touch of a button.

Engine

Power and reliability



Cat C7 and C9 ACERT engines give you the performance you need to maintain consistent grading speeds for maximum productivity. Superior torque and lugging capability provide the power to pull through sudden, short-term increases in loads.

ACERT Technology lowers combustion chamber temperatures and optimizes fuel combustion to generate more work output for your fuel cost. ACERT engines also generate fewer emissions to meet the needs of equipment owners around the world.

Hydraulic Demand Fan

The hydraulic demand fan automatically adjusts speed according to engine cooling requirements. When cooling demand is reduced, you benefit from more power to the ground and improved fuel efficiency.

Engine Idle Shutdown Timer

This standard feature can be software-enabled by your Cat dealer to shut down the engine after a set period of time to save you fuel and help reduce emissions.



Power Train

Maximum power to the ground

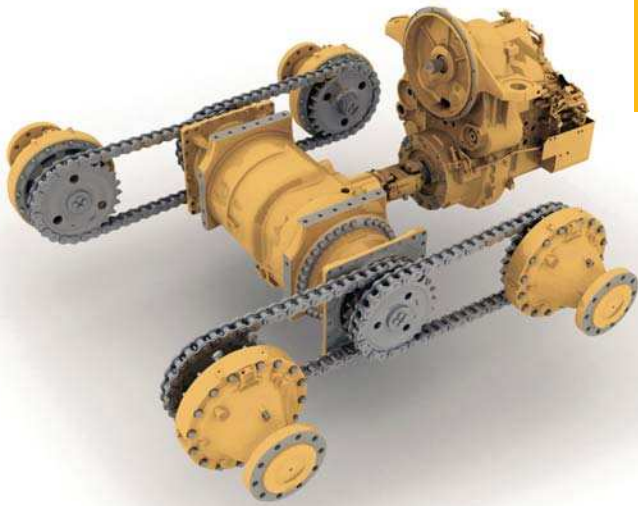

We designed the M Series Motor Graders to give you efficiency and longevity in your most demanding applications.

- Standard Automatic Differential Lock/Unlock unlocks the differential during a turn and re-locks when straight for easier operation and to help protect the power train.
- Full Electronic Clutch Pressure Control system optimizes inching modulation for smooth shifts and directional changes, reducing stress on gears.
- Programmable Autoshift option simplifies operation by allowing the operator to program the transmission to shift at optimal points to match your application.
- Power Shift Countershaft Transmission is matched to the Cat engine to maximize power to the ground.
- Wide operating gear range for maximum productivity.
- Engine Over-Speed Protection prevents downshifting until an acceptable safe travel speed has been established.

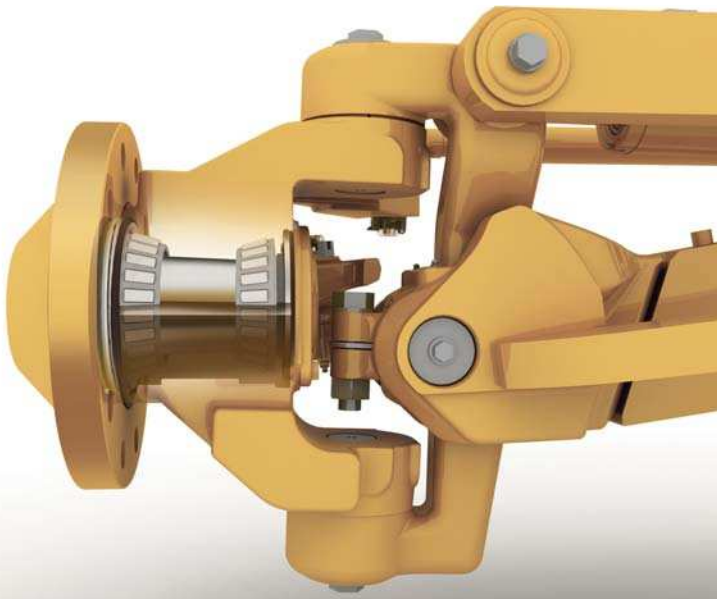

Front and Rear Axles

The sealed spindle keeps front axle bearings lubricated and protected from contaminants. The Cat "Live Spindle" design places the larger tapered roller bearing on the outside, where the load is greater, extending bearing life.

A bolt-on modular rear axle improves serviceability and contamination control with easy access to differential components.

Hydraulic Brakes

Oil-bathed multi-disc service brakes are hydraulically actuated for smooth, predictable braking and lower operating costs. Brakes are located at each tandem wheel and have a large total brake surface area to give you dependable stopping power and longer life.

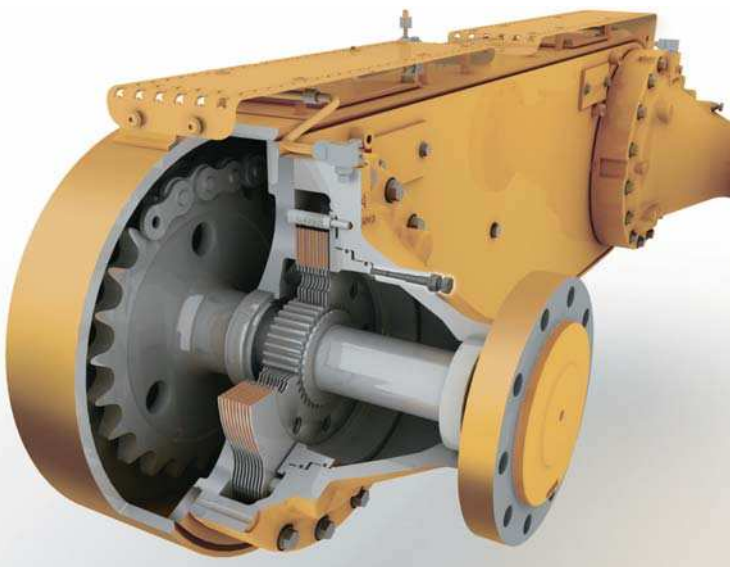

Structures and Drawbar-Circle-Moldboard

Service ease and precise blade control

Caterpillar designs motor grader frame and drawbar components to give you performance and durability. The one-piece forged steel circle stands up to high stress loads, and a sacrificial wear system helps keep your service time and costs down.

The articulation hitch features a large tapered roller bearing to carry loads evenly and smoothly. It is sealed to prevent contamination and a locking pin prevents articulation for safety during service or transport.

Easy Maintenance for More Uptime

The M Series drawbar, circle and moldboard are designed to make it easy for you to keep the components tight. Shims and patented top-adjust wear strips are easy to add or replace, dramatically reducing downtime. Durable nylon composite wear inserts maximize circle torque and component life. Sacrificial brass wear strips between the blade mounting group and moldboard can be easily adjusted and replaced. Shimless Moldboard Retention System uses vertical and horizontal adjusting screws to keep moldboard wear strips aligned for reduced blade chatter and precise blade control.

Blade Angle and Moldboard

An aggressive blade angle, optimized moldboard curvature and large throat clearance help you work more efficiently by allowing material to roll more freely along the blade.

Heat-treated rails, hardened cutting edges and end bits, and heavy duty bolts to give you greater moldboard reliability and long service life. The link bar allows extreme moldboard positioning for easier bank sloping and ditch cutting/cleaning.

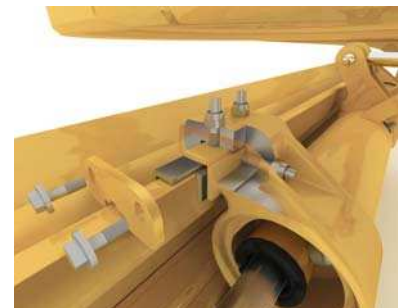
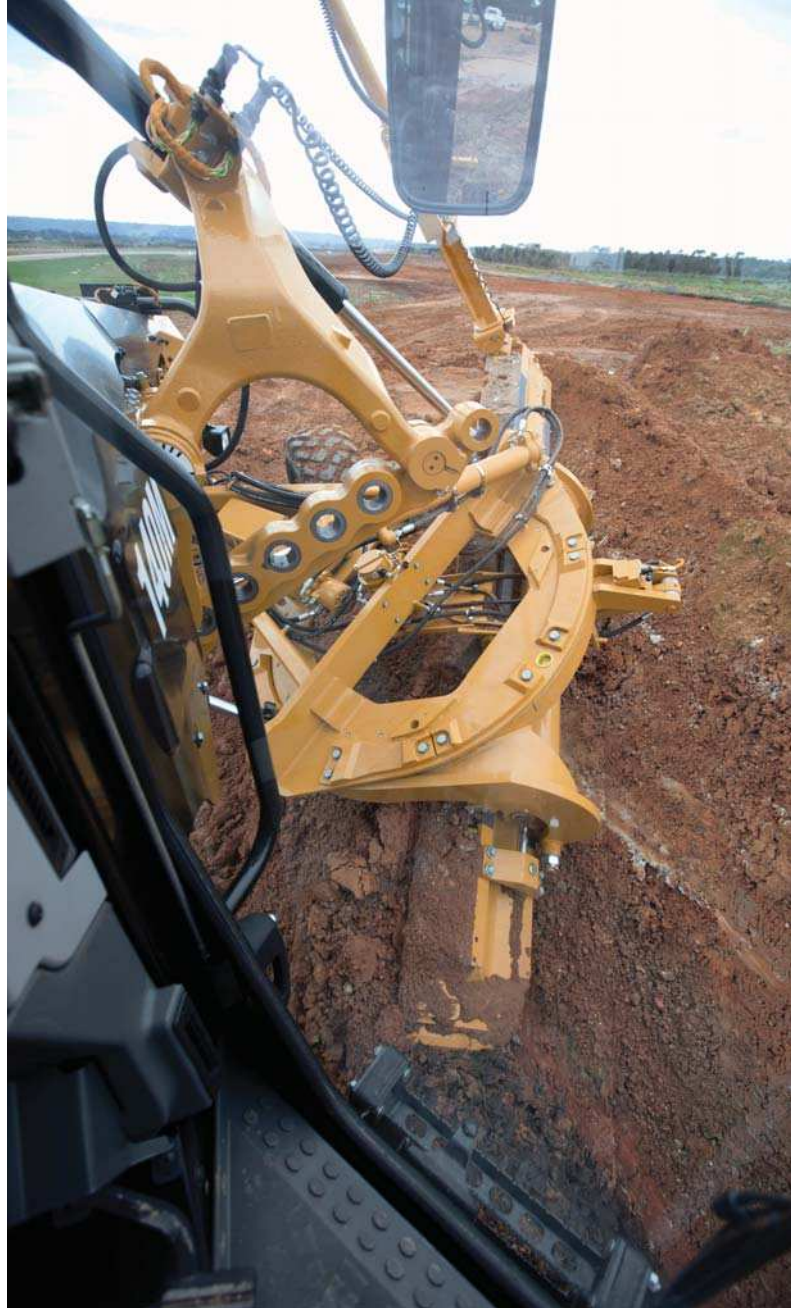



Hydraulics

Advanced machine control

Responsive Hydraulics

A proven load-sensing system and advanced electro-hydraulics give you superior implement control and responsive hydraulic performance that helps make your operator's job easier. Continuously matching hydraulic flow/pressure to power demands creates less heat and reduces power consumption.

- Consistent, Predictable Movement – Proportional Priority Pressure-Compensating (PPP-C) valves have different flow rates for the head and rod ends of the cylinder, so you can count on consistent, predictable implement response.
- Balanced Flow – Hydraulic flow is proportioned to give you confidence that all implements will operate simultaneously without slowing the engine or speed of some implements.

Blade Float

Allows the blade to move freely under its own weight. By floating both cylinders, the blade can follow the contours of the ground. Floating only one cylinder permits the toe of the blade to follow a hard surface while the operator controls the slope with the other lift cylinder.

Independent Oil Supply

Large, separate hydraulic oil supplies prevent cross-contamination and provide proper oil cooling, which reduces heat build-up and extends component life. Cat XT™ hose allows high pressures for maximum power and reduced downtime.



All Wheel Drive (AWD)

Expanded machine versatility



If you work in soft underfoot conditions where traction can be a challenge, optional All Wheel Drive (AWD) can give you the additional power to the ground you need to work more efficiently in mud, gravel, sand or snow. The added traction helps reduce sliding on side slopes.

- Dedicated left and right pumps give you more precise hydraulic control. The infinitely variable pumps and motors maximize torque in each gear.
- AWD automatically increases your horsepower up to an additional 26 kW (35 hp) to maximize your power to the ground.
- Standard Hydrostatic (Creep) Mode disengages the transmission and provides hydraulic power to the front wheels only. Infinitely variable ground speed between 0-8 km/h (0-5 mph) is ideal for precise finish work.
- Cat Steering Compensation System enables a “powered turn” by adjusting the outside front tire speed up to 50% faster than the inside tire. This gives you improved control, reduces surface damage and greatly reduces turning radius in poor underfoot conditions.



■ Without Steering Compensation ■ With Steering Compensation

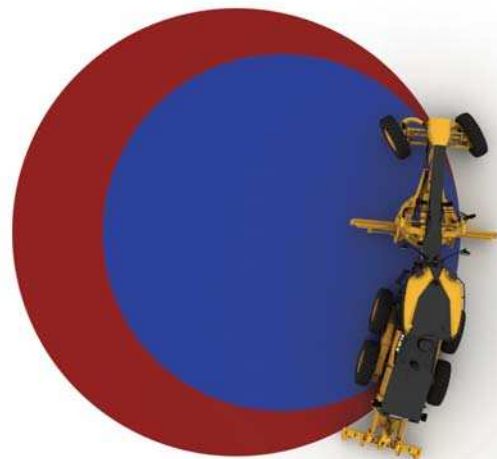

Integrated Technologies

Solutions to make work easier and more efficient



Cat Grade Control

Cat Grade Control Cross Slope is an optional fully integrated, factory installed system that helps your operator more easily maintain desired cross slope by automatically controlling one side of the blade. The system is job-ready from day one, and scalable for the future with AccuGrade™ upgrade kits that provide additional 2D and/or 3D control.

AccuGrade Attachment Ready Option

An AccuGrade Attachment Ready Option can be ordered as a factory- or dealer-installed option. It includes built-in mounting points and internal wiring, to make installation of the AccuGrade grade control system faster and easier.

Cat AccuGrade

AccuGrade uses positioning and guidance technologies, machine sensors, and automatic blade control to help your operators get to grade faster, easier and more efficiently. Digital design plans, real-time cut/fill data, and in-cab guidance give operators detailed information to work more confidently and achieve greater accuracy, in fewer passes, using less material. Operators can stay on grade and improve productivity and accuracy by nearly 50 percent over conventional methods. Grade stakes and checkers are minimized, helping to make the work site safer and more cost effective. AccuGrade technologies include Cross Slope, Sonic, Laser, GPS, and/or Universal Total Station (UTS).

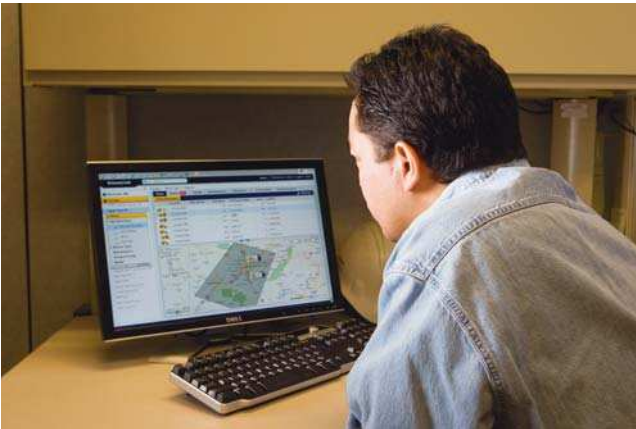

Cat Product Link™

Product Link helps take the guesswork out of equipment management with remote monitoring capabilities for one machine or your entire fleet. Track asset location, hours, fuel usage, diagnostic codes, idle time and more through the secure VisionLink™ user interface. Knowing where your equipment is, what it's doing and how it's performing enables you or your Cat dealer to manage your fleet in real-time so you can maximize efficiency, improve productivity and lower operating costs.*

**Product Link licensing not available in all areas. Please consult your Cat dealer for availability.*



Safety

Designed with protection in mind



M Series Safety Features

- Rearview camera with in-cab monitor
- Grouped, ground level service points
- Laminated front window glass
- Optional LED Lighting
- Ground-level electrical disconnect switch
- Ground-level engine shutoff switch
- Anti-glare paint eases night operation
- Front and rear fenders

Operator Not Present Monitoring System

System keeps the parking brake engaged and hydraulic implements disabled until the operator is seated and the machine is ready for operation.

Speed Sensitive Steering

Steering becomes less sensitive as ground speed increases for greater operator confidence and control.

Secondary Steering System

An electric hydraulic pump automatically engages in case of a drop in steering pressure so the operator can steer the machine to a stop.

Hydraulic Lockout

Hydraulic lockout disables all implement functions while still providing machine steering control. This is especially useful while roading.

Brake Systems

Brakes are located at each tandem wheel to eliminate braking loads on the power train. Redundant brake systems utilize accumulators to enable stopping in case of machine failure.

Walkways and Grab Rails

Perforated steel tandem walkways and convenient grab rails give you a sturdy platform when moving on, off and around the machine.

Circle Drive Slip Clutch

Circle Drive Slip Clutch protects the drawbar, circle and moldboard from shock loads if the blade encounters an immovable object and also reduces the possibility of abrupt directional changes in poor traction conditions.

Blade Lift Accumulators

Blade Lift Accumulators help absorb impact loads by allowing vertical blade travel. This optional feature helps reduce wear and also helps reduce impact loading for enhanced operator safety.





Smart Machine Systems

Advanced Diagnostics

Serviceability and Customer Support

When uptime counts

Cat motor graders are designed to help you increase uptime and reduce costs. Grouped service points and extended service intervals save maintenance time. A standard Automatic Lubrication System maintains proper grease on working surfaces, increasing component life and purging contaminants from pins and bushings to help prevent damage. Standard Fast-Fill allows customers to refuel in less than four minutes so you can get back on the job quickly.

Unparalleled Dealer Support

When it comes to supporting you, Cat dealers are second to none. From machine selection and purchase to maintenance support and rebuilds, Cat dealers have the experience and capabilities to help keep you up and running.

- Cat Messenger, combined with full systems integration, enhances diagnostic capability for quick analysis of critical data.
- Electronic Technician (Cat ET) lets service technicians access stored diagnostic data and configure machine parameters through the Cat Data Link.
- Low Battery Elevated Idle raises idle speed when low system voltage is detected, ensuring adequate system voltage and improving battery reliability.
- Automatic Engine Deration protects the engine by automatically lowering engine torque output and alerting the operator if critical conditions are detected.





Work Tools and Attachments

Equip your machine for the job

Moldboard Options

The 140M and 160M motor graders come equipped with a 3.7 m (12 ft) moldboard. An optional 4.3 m (14 ft) blade is available for all models, as well as a 4.9 m (16 ft) moldboard for the 160M. Left side extensions can be added for greater versatility.

Snow Removal Work Tools

Multiple snow plow, snow wing and mounting options increase machine versatility and utilization throughout the year.



Ground Engaging Tools (GET)

A variety of tools are available from Cat Work Tools, including cutting edges, graderbits and end bits, all designed for maximum service life and productivity.

Front Mounted Groups

A front mounted push plate or front lift group are available. The front lift group can be combined with a front dozer blade or front scarifier for added versatility.

Rear Ripper/Scarifier

Made to penetrate tough material fast and rip thoroughly for easier movement with the moldboard. The ripper includes three shanks (with holders for five). Nine scarifier shanks can also be added for additional versatility.

Sustainability

Thinking generations ahead



Fuel Efficiency

- Integrated machine systems and technologies improve productivity for greater accuracy, allowing the machine to do more work per gallon/liter of fuel.

Green House Gas Emissions

- Reduced fuel consumption means reduced CO₂ emissions.

Material Efficiency and Lifecycle Costs

- Replaceable wear parts save maintenance time and cost, and extend major component life.
- Major components are built to be rebuilt, eliminating waste and saving customers money by giving the machine and/or major components a second – and even third-life.
- Approximately 95% of machine materials can be recycled (ISO 16714) to conserve valuable natural resources and further enhance machine end-of-life value.

Sound

- Reduced engine noise and quieter cabs mean lower operator and spectator sound levels.

Safety

- Ecology drains help make draining fluids more convenient and help prevent spills.
- Cartridge style hydraulic fluid filters provide safe clean draining of filters prior to replacement, helping to prevent fluid spills.
- A variety of safety features help safeguard operators and others on the job site.

140M/140M AWD Motor Graders Specifications

Engine

Engine Model*	Cat C7 ACERT	
Base Power (1st gear) – Net	136 kW	183 hp
VHP Plus Range – Net	136-174 kW	183-233 hp
Displacement	7.2 L	439 in ³
Bore	110 mm	4.3 in
Stroke	127 mm	5 in
Torque Rise (VHP Plus)	39%	
Maximum Torque (VHP Plus)	1159 N·m	855 lbf-ft
Speed @ Rated Power	2,000 rpm	
Number of Cylinders	6	
Derating Altitude	3048 m	10,000 ft
Standard – Fan Speed		
Maximum	1,450 rpm	
Minimum	600 rpm	
Standard – Ambient Capability	43° C	109° F
High Ambient – Fan Speed		
Maximum	1,650 rpm	
Minimum	600 rpm	
High Ambient Capability	50° C	122° F

- Maximum torque (VHP Plus) measured at 1,000 rpm.
 - Net power is tested per ISO 9249, SAE J1349, and EEC 80/1269 Standards in effect at the time of manufacture.
 - Net power advertised is the power available at rated speed of 2,000 rpm, measured at the flywheel when engine is equipped with fan running at minimum speed, air cleaner, muffler and alternator.
 - Power as declared per ISO 14396
Rated Speed = 2,000 rpm
VHP Plus = 175 kW (234 hp)
 - No engine derating required up to 3048 m (10,000 ft).
- * Note: Engine is Certified for Environment Canada Tier 3 standards.

Engine – AWD Model

Engine Model*	Cat C9 ACERT	
Base Power (1st gear, AWD off) – Net	159 kW	213 hp
VHP Plus Range – Net	159-200 kW	213-268 hp
Displacement	8.8 L	537 in ³
Bore	112 mm	4.4 in
Stroke	149 mm	5.9 in
Torque Rise (VHP Plus)	40%	
Maximum Torque (AWD on)	1344 N·m	991 lbf-ft
Speed @ Rated Power	2,000 rpm	
Number of Cylinders	6	
Derating Altitude	3048 m	10,000 ft
High Ambient – Fan Speed		
Maximum	1,650 rpm	
Minimum	600 rpm	
High Ambient Capability	50° C	122° F

- Maximum torque (VHP Plus) measured at 1,000 rpm.
 - Net power is tested per ISO 9249, SAE J1349, and EEC 80/1269 Standards in effect at the time of manufacture.
 - Net power advertised is the power available at rated speed of 2,000 rpm, measured at the flywheel when engine is equipped with fan running at minimum speed, air cleaner, muffler and alternator.
 - Power as declared per ISO 14396
Rated Speed = 2,000 rpm
AWD = 201 kW (269 hp)
 - No engine derating required up to 3048 m (10,000 ft).
- * Note: Engine is Certified for Environment Canada Tier 3 standards.

140M/140M AWD Motor Graders Specifications

140M Net Power

Gear	VHP Plus kW (hp)	AWD Off kW (hp)	AWD On kW (hp)
Forward			
1st	136 (183)	159 (213)	166 (223)
2nd	140 (188)	162 (218)	177 (238)
3rd	151 (203)	166 (223)	181 (243)
4th	155 (208)	170 (228)	185 (248)
5th	159 (213)	174 (233)	200 (268)
6th	163 (218)	177 (238)	200 (268)
7th	174 (233)	181 (243)	200 (268)
8th	174 (233)	185 (248)	200 (268)
Reverse			
1st	136 (183)	159 (213)	159 (213)
2nd	140 (188)	162 (218)	162 (218)
3rd – 6th	151 (203)	166 (223)	166 (223)

Power Train

Forward/Reverse Gears	8 Forward/6 Reverse
Transmission	Direct drive, power shift, countershaft
Brakes	
Service	Multiple oil disc
Service, Surface Area	23 000 cm ² 3,565 in ²
Parking	Multiple oil disc
Secondary	Dual circuit control system

Hydraulic System

Circuit Type	Electro-hydraulic load sensing, closed center	
Pump Type	Variable piston	
Pump Output	210 L/min	55.7 gal/min
Maximum System Pressure	24 150 kPa	3,500 psi
Standby Pressure	3100 kPa	450 psi

- Pump output measured at 2,150 rpm.

Operating Specifications

Top Speed		
Forward	46.6 km/h	29.0 mph
Reverse	36.8 km/h	22.9 mph
Turning Radius, Outside Front Tires	7.6 m	24 ft 10 in
Steering Range – Left/Right	47.5 degrees	
Articulation Angle – Left/Right	20 degrees	
Forward		
1st	4.0 km/h	2.5 mph
2nd	5.5 km/h	3.4 mph
3rd	8.0 km/h	5.0 mph
4th	11.0 km/h	6.8 mph
5th	17.1 km/h	10.6 mph
6th	23.3 km/h	14.5 mph
7th	32.0 km/h	19.9 mph
8th	46.6 km/h	29.0 mph
Reverse		
1st	3.2 km/h	2.0 mph
2nd	6.0 km/h	3.7 mph
3rd	8.7 km/h	5.4 mph
4th	13.5 km/h	8.4 mph
5th	25.3 km/h	15.7 mph
6th	36.8 km/h	22.9 mph

- Speeds when equipped with 14.0R24 tires.

Service Refill

Fuel Capacity	416 L	110 gal
Cooling System	40 L	10.6 gal
Hydraulic System – Tank	64 L	16.9 gal
Engine Oil	25 L	6.6 gal
Trans./Diff./Final Drives	64 L	16.9 gal
Tandem Housing (each)	64 L	16.9 gal
Front Wheel Spindle Bearing Housing	0.5 L	0.13 gal
Circle Drive Housing	7 L	1.8 gal

Optional Tire Arrangements

140M/140M AWD

Rim Size	Wheel Group	Tires
10 × 24	Multi-Piece	14.00-24
10 × 24	Multi-Piece	14.00R24
14 × 25	Multi-Piece	17.5R25

Note: Consult your dealer for individual tire width, size, and brand.

140M/140M AWD Motor Graders Specifications

Frame

Circle		
Diameter	1530 mm	60.2 in
Height	138 mm	5.4 in
Blade Beam Thickness	40 mm	1.6 mm
Drawbar		
Height	152 mm	6 in
Width	76.2 mm	3 in
Front Frame Structure		
Height	305 mm	12 in
Width	305 mm	12 in
Thickness	16 mm	0.6 in
Front Axle		
Height to Center	571 mm	23 in
Wheel Lean, Left/Right	18 degrees	
Total Oscillation Per Side	32 degrees	

Tandems

Height	506 mm	19.9 in
Width	201 mm	7.9 in
Sidewall Thickness		
Inner	16 mm	0.6 in
Outer	18 mm	0.7 in
Drive Chain Pitch	50.8 mm	2 in
Wheel Axle Spacing	1523 mm	60 in
Tandem Oscillation		
Front Up	15 degrees	
Front Down	25 degrees	

Moldboard

Moldboard		
Width	3.7 m	12 ft
Height	610 mm	24 in
Thickness	22 mm	0.87 in
Arc Radius	413 mm	16.3 in
Throat Clearance	166 mm	6.5 in
Cutting Edge		
Width	152 mm	6 in
Thickness	16 mm	0.6 in
End Bit		
Width	152 mm	6 in
Thickness	16 mm	0.6 in
Blade Pull		
Base GVW	11 020 kg	24,294 lb
Maximum GVW	14 405 kg	31,758 lb
Base GVW (AWD)	15 816 kg	34,869 lb
Maximum GVW (AWD)	21 184 kg	46,703 lb
Down Pressure		
Base GVW	7444 kg	16,410 lb
Maximum GVW	12 929 kg	28,503 lb
Base GVW (AWD)	8320 kg	18,342 lb
Maximum GVW (AWD)	12 929 kg	28,503 lb

- Blade pull calculated at 0.9 traction coefficient, which is equal to no-slip conditions, and Gross Machine Weight.

140M/140M AWD Motor Graders Specifications

Blade Range

Circle Centershift		
Right	728 mm	28.7 in
Left	695 mm	27.4 in
Moldboard Sideshift		
Right	660 mm	26 in
Left	510 mm	20.1 in
Maximum Blade Position Angle	90 degrees	
Blade Tip Range		
Forward	40 degrees	
Backward	5 degrees	
Maximum Shoulder Reach Outside of Tires		
Right	1978 mm	77.9 in
Left	1790 mm	70.5 in
Maximum Lift Above Ground	480 mm	18.9 in
Maximum Depth of Cut	715 mm	28.1 in

Ripper

Ripping Depth, Maximum	428 mm	16.8 in
Ripper Shank Holders	5	
Ripper Shank Holder Spacing	533 mm	21 in
Penetration Force	9317 kg	20,540 lb
Pryout Force	11 911 kg	26,259 lb
Machine Length Increase, Beam Raised	919 mm	36.2 in

Scarifier

Front, V-Type, 5 or 11 Tooth		
Working Width	1205 mm	47.4 in
Scarifying Depth, Maximum	467 mm	18.4 in
Scarifier Shank Holders	5/11	
Scarifier Shank Holder Spacing	116 mm	4.6 in
Mid, V-Type		
Working Width	1184 mm	46.6 in
Scarifying Depth, Maximum	292 mm	11.5 in
Scarifier Shank Holders	11	
Scarifier Shank Holder Spacing	116 mm	4.6 in
Rear		
Working Width	2300 mm	91 in
Scarifying Depth, Maximum	266 mm	10.5 in
Scarifier Shank Holders	9	
Scarifier Shank Holder Spacing	267 mm	10.5 in

Weights

Gross Vehicle Weight – Base		
Total	16 581 kg	36,554 lb
Front Axle	4337 kg	9,561 lb
Rear Axle	12 244 kg	26,993 lb
Gross Vehicle Weight – Maximum		
Total	23 538 kg	51,892 lb
Front Axle	7532 kg	16,606 lb
Rear Axle	16 006 kg	35,287 lb
Gross Vehicle Weight – Typically Equipped		
Total	18 991 kg	41,868 lb
Front Axle	5314 kg	11,716 lb
Rear Axle	13 677 kg	30,152 lb

- Base operating weight calculated on standard machine configuration with 14.00R24 tire with multi-piece rim, full fuel tank, coolant, lubricants and operator.

Weights – AWD

Gross Vehicle Weight – Base		
Total	17 573 kg	38,743 lb
Front Axle	4847 kg	10,686 lb
Rear Axle	12 726 kg	28,057 lb
Gross Vehicle Weight – Maximum		
Total	23 538 kg	51,892 lb
Front Axle	7532 kg	16,606 lb
Rear Axle	16 006 kg	35,287 lb
Gross Vehicle Weight – Typically Equipped		
Total	19 883 kg	43,834 lb
Front Axle	5791 kg	12,767 lb
Rear Axle	14 092 kg	31,067 lb

- Base operating weight calculated on standard machine configuration with 14.00R24 tire with multi-piece rim, full fuel tank, coolant, lubricants and operator.

Standards

ROPS/FOPS	ISO 3471:1994, ISO 3449:1992
Steering	ISO 5010:2007
Brakes	ISO 3450:1996
Sound	ISO 6394:2008, ISO 6395:2008

- The static operator sound pressure level is 74 dB(A) when “ISO 6394:2008” is used to measure the value for an enclosed cab. The measurement was conducted with the cab doors and the cab windows closed. The cab was properly installed and maintained.
- 140M – The dynamic spectator sound pressure level is 106 dB(A) when “ISO 6395:2008” is used to measure the value for an enclosed cab. The measurement was conducted at 70% of the maximum engine cooling fan speed.
- 140M AWD – The dynamic spectator sound pressure level is 107 dB(A) when “ISO 6395:2008” is used to measure the value for an enclosed cab. The measurement was conducted at 70% of the maximum engine cooling fan speed.

160M/160M AWD Motor Graders Specifications

Engine

Engine Model*	Cat C9 ACERT	
Base Power (1st gear) – Net	159 kW	213 hp
VHP Plus Range – Net	159-185 kW	213-248 hp
Displacement	8.8 L	537 in ³
Bore	112 mm	4.4 in
Stroke	149 mm	5.9 in
Torque Rise (VHP Plus)	40%	
Maximum Torque (VHP Plus)	1237 N·m	912 lbf-ft
Speed @ Rated Power	2,000 rpm	
Number of Cylinders	6	
Derating Altitude	3048 m	10,000 ft
Standard – Fan Speed		
Maximum	1,450 rpm	
Minimum	600 rpm	
Standard – Ambient Capability	43° C	109° F
High Ambient – Fan Speed		
Maximum	1,650 rpm	
Minimum	600 rpm	
High Ambient Capability	50° C	122° F

- Maximum torque (VHP Plus) measured at 1,000 rpm.
 - Net power is tested per ISO 9249, SAE J1349, and EEC 80/1269 Standards in effect at the time of manufacture.
 - Net power advertised is the power available at rated speed of 2,000 rpm, measured at the flywheel when engine is equipped with fan running at minimum speed, air cleaner, muffler and alternator.
 - Power as declared per ISO 14396
Rated Speed = 2,000 rpm
VHP Plus = 186 kW (249 hp)
 - No engine derating required up to 3048 m (10,000 ft).
- * Note: Engine is Certified for Environment Canada Tier 3 standards.

Engine – AWD Model

Engine Model*	Cat C9 ACERT	
Base Power (1st gear) – Net	159 kW	213 hp
VHP Plus Range – Net	159-200 kW	213-268 hp
Displacement	8.8 L	537 in ³
Bore	112 mm	4.4 in
Stroke	149 mm	5.9 in
Torque Rise (VHP Plus)	40%	
Maximum Torque (AWD on)	1344 N·m	991 lbf-ft
Speed @ Rated Power	2,000 rpm	
Number of Cylinders	6	
Derating Altitude	3048 m	10,000 ft
High Ambient – Fan Speed		
Maximum	1,650 rpm	
Minimum	600 rpm	
High Ambient Capability	50° C	122° F

- Maximum torque (VHP Plus) measured at 1,000 rpm.
 - Net power is tested per ISO 9249, SAE J1349, and EEC 80/1269 Standards in effect at the time of manufacture.
 - Net power advertised is the power available at rated speed of 2,000 rpm, measured at the flywheel when engine is equipped with fan running at minimum speed, air cleaner, muffler and alternator.
 - Power as declared per ISO 14396
Rated Speed = 2,000 rpm
AWD = 201 kW (269 hp)
 - No engine derating required up to 3048 m (10,000 ft).
- * Note: Engine is Certified for Environment Canada Tier 3 standards.

160M/160M AWD Motor Graders Specifications

160M Net Power

Gear	VHP Plus kW (hp)	AWD Off kW (hp)	AWD On kW (hp)
Forward			
1st	159 (213)	159 (213)	166 (223)
2nd	162 (218)	162 (218)	177 (238)
3rd	166 (223)	166 (223)	181 (243)
4th	170 (228)	170 (228)	185 (248)
5th	174 (233)	174 (233)	200 (268)
6th	177 (238)	177 (238)	200 (268)
7th	181 (243)	181 (243)	200 (268)
8th	185 (248)	185 (248)	200 (268)
Reverse			
1st	159 (213)	159 (213)	159 (213)
2nd	162 (218)	162 (218)	162 (218)
3rd – 6th	166 (223)	166 (223)	166 (223)

Power Train

Forward/Reverse Gears	8 Forward/6 Reverse
Transmission	Direct drive, power shift, countershaft
Brakes	
Service	Multiple oil disc
Service, Surface Area	23 000 cm ² 3,565 in ²
Parking	Multiple oil disc
Secondary	Dual circuit control system

Hydraulic System

Circuit Type	Electro-hydraulic load sensing, closed center	
Pump Type	Variable piston	
Pump Output	210 L/min	55.7 gal/min
Maximum System Pressure	24 150 kPa	3,500 psi
Standby Pressure	3100 kPa	450 psi

- Pump output measured at 2,150 rpm.

Operating Specifications

Top Speed		
Forward	47.4 km/h	29.5 mph
Reverse	37.4 km/h	23.3 mph
Turning Radius, Outside Front Tires	7.6 m	24 ft 11 in
Steering Range – Left/Right	47.5 degrees	
Articulation Angle – Left/Right	20 degrees	
Forward		
1st	4.1 km/h	2.5 mph
2nd	5.6 km/h	3.5 mph
3rd	8.1 km/h	5.0 mph
4th	11.2 km/h	7.0 mph
5th	17.4 km/h	10.8 mph
6th	23.7 km/h	14.7 mph
7th	32.6 km/h	20.3 mph
8th	47.4 km/h	29.5 mph
Reverse		
1st	3.3 km/h	2.0 mph
2nd	6.1 km/h	3.8 mph
3rd	8.8 km/h	5.5 mph
4th	13.7 km/h	8.5 mph
5th	25.7 km/h	16.0 mph
6th	37.4 km/h	23.3 mph

- Speeds when equipped with 14.0R24 tires.

Service Refill

Fuel Capacity	416 L	110 gal
Cooling System	40 L	10.6 gal
Hydraulic System – Tank	64 L	16.9 gal
Engine Oil	30 L	7.9 gal
Trans./Diff./Final Drives	65 L	17.2 gal
Tandem Housing (each)	80 L	21.1 gal
Front Wheel Spindle Bearing Housing	0.5 L	0.13 gal
Circle Drive Housing	7 L	1.8 gal

Optional Tire Arrangements

160M/160M AWD

Rim Size	Wheel Group	Tires
10 × 24	Multi-Piece	14.00-24
10 × 24	Multi-Piece	14.00R24
14 × 25	Multi-Piece	17.5R25

Note: Consult your dealer for individual tire width, size, and brand.

160M/160M AWD Motor Graders Specifications

Frame

Circle		
Diameter	1553 mm	61.1 in
Height	160 mm	6.3 in
Blade Beam Thickness	40 mm	1.6 in
Drawbar		
Height	152 mm	6 in
Width	76.2 mm	3 in
Front Frame Structure		
Height	305 mm	12 in
Width	305 mm	12 in
Thickness	16 mm	0.6 in
Front Axle		
Height to Center	571 mm	22.5 in
Wheel Lean, Left/Right	18 degrees	
Total Oscillation Per Side	32 degrees	

Tandems

Height	572 mm	22.5 in
Width	204 mm	8 in
Sidewall Thickness		
Inner	25 mm	1 in
Outer	18 mm	0.7 in
Drive Chain Pitch	50.8 mm	2 in
Wheel Axle Spacing	1523 mm	60 in
Tandem Oscillation		
Front Up	15 degrees	
Front Down	25 degrees	

Moldboard

Moldboard		
Width	3.7 m	12 ft
Height	610 mm	24 in
Thickness	22 mm	0.87 in
Arc Radius	413 mm	16.3 in
Throat Clearance	95 mm	3.7 in
Cutting Edge		
Width	152 mm	6 in
Thickness	16 mm	0.6 in
End Bit		
Width	152 mm	6 in
Thickness	16 mm	0.6 in
Blade Pull		
Base GVW	11 110 kg	24,494 lb
Maximum GVW	14 656 kg	32,310 lb
Base GVW (AWD)	16 032 kg	35,344 lb
Maximum GVW (AWD)	21 552 kg	47,515 lb

Down Pressure		
Base GVW	7682 kg	16,936 lb
Maximum GVW	13 153 kg	28,998 lb
Base GVW (AWD)	8558 kg	18,868 lb
Maximum GVW (AWD)	13 153 kg	28,998 lb

- Blade pull calculated at 0.9 traction coefficient, which is equal to no-slip conditions, and Gross Machine Weight.

Blade Range

Circle Centershift		
Right	728 mm	28.7 in
Left	695 mm	27.4 in
Moldboard Sideshift		
Right	950 mm	37.4 in
Left	820 mm	32.3 in
Maximum Blade Position Angle	90 degrees	
Blade Tip Range		
Forward	40 degrees	
Backward	5 degrees	
Maximum Shoulder Reach Outside of Tires		
Right	2278 mm	89.7 in
Left	2090 mm	82.3 in
Maximum Lift Above Ground	452 mm	17.8 in
Maximum Depth of Cut	750 mm	29.5 in

160M/160M AWD Motor Graders Specifications

Ripper

Ripping Depth, Maximum	428 mm	16.8 in
Ripper Shank Holders	5	
Ripper Shank Holder Spacing	533 mm	21 in
Penetration Force	9317 kg	20,540 lb
Pryout Force	11 911 kg	26,259 lb
Machine Length Increase, Beam Raised	995 mm	39.2 in

Scarifier

Front, V-Type, 5 or 11 Tooth		
Working Width	1205 mm	47.4 in
Scarifying Depth, Maximum	467 mm	18.4 in
Scarifier Shank Holders	5/11	
Scarifier Shank Holder Spacing	116 mm	4.6 in
Mid, V-Type		
Working Width	1184 mm	46.6 in
Scarifying Depth, Maximum	292 mm	11.5 in
Scarifier Shank Holders	11	
Scarifier Shank Holder Spacing	116 mm	4.6 in
Rear		
Working Width	2300 mm	91 in
Scarifying Depth, Maximum	266 mm	10.5 in
Scarifier Shank Holders	9	
Scarifier Shank Holder Spacing	267 mm	10.5 in

Weights

Gross Vehicle Weight – Base		
Total	16 820 kg	37,082 lb
Front Axle	4475 kg	9,867 lb
Rear Axle	12 345 kg	27,215 lb
Gross Vehicle Weight – Maximum		
Total	23 947 kg	52,794 lb
Front Axle	7663 kg	16,894 lb
Rear Axle	16 284 kg	35,900 lb
Gross Vehicle Weight – Typically Equipped		
Total	19 715 kg	43,465 lb
Front Axle	5626 kg	12,404 lb
Rear Axle	14 089 kg	31,061 lb

- Base operating weight calculated on standard machine configuration with 17.50R25 tire with a multi-piece rim, full fuel tank, coolant, lubricants and operator.

Weights – AWD

Gross Vehicle Weight – Base		
Total	17 813 kg	39,271 lb
Front Axle	4986 kg	10,992 lb
Rear Axle	12 827 kg	28,278 lb
Gross Vehicle Weight – Maximum		
Total	23 947 kg	52,794 lb
Front Axle	7663 kg	16,894 lb
Rear Axle	16 284 kg	35,900 lb
Gross Vehicle Weight – Typically Equipped		
Total	20 607 kg	45,432 lb
Front Axle	6103 kg	13,455 lb
Rear Axle	14 504 kg	31,976 lb

- Base operating weight calculated on standard machine configuration with 14.00R24 tire with multi-piece rim, full fuel tank, coolant, lubricants and operator.

Standards

ROPS/FOPS	ISO 3471:1994, ISO 3449:1992
Steering	ISO 5010:2007
Brakes	ISO 3450:1996
Sound	ISO 6394:2008, ISO 6395:2008

- The static operator sound pressure level is 73 dB(A) when “ISO 6394:2008” is used to measure the value for an enclosed cab. The measurement was conducted with the cab doors and the cab windows closed. The cab was properly installed and maintained.
- The dynamic spectator sound pressure level is 107 dB(A) when “ISO 6395:2008” is used to measure the value for an enclosed cab. The measurement was conducted at 70% of the maximum engine cooling fan speed.

140M/140M AWD/160M/160M AWD Motor Graders Specifications

Dimensions

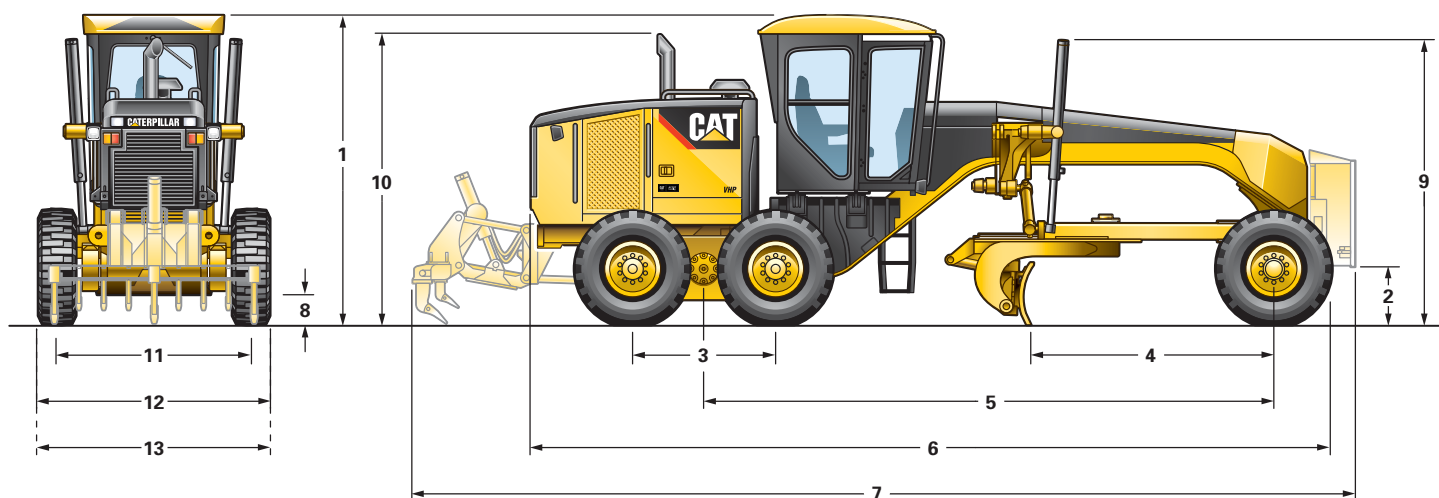

	140M/140M AWD		160M/160M AWD	
	mm	in	mm	in
1 Height – Top of Cab	3308	130.2	3308	130.2
Height – Top of Cab Product Link	3378	133.0	3378	133.0
2 Height – Front Axle Center	596	23.5	596	23.5
3 Length – Between Tandem Axles	1523	60.0	1523	60.0
4 Length – Front Axle to Moldboard	2552	100.5	2552	100.5
5 Length – Front Axle to Mid Tandem	6123	241.1	6123	241.1
6 Length – Front Tire to Rear of Machine	8754	344.6	8754	344.6
7 Length – Push Plate to Ripper	10 136	399.1	10 136	399.1
Length – Push Plate to Ripper Retracted	9818	386.5	9818	386.5
8 Ground Clearance at Rear Axle	339	13.3	339	13.3
9 Height to Top of Cylinders	3040	119.7	3040	119.7
10 Height to Exhaust Stack	3076	121.1	3256	128.2
Height to Exhaust Stack (AWD)	3256	128.2	3256	128.2
11 Width – Tire Center Lines	2140	84.3	2140	84.3
Width – Tire Center Lines Front (AWD)	2223	87.5	2223	87.5
12 Width – Outside Rear Tires	2511	98.9	2511	98.9
13 Width – Outside Front Tires	2511	98.9	2511	98.9
Width – Outside Front Tires (AWD)	2594	102.1	2594	102.1

Dimensions based on 14.00R24 tire on multi-piece rim. Dimensions may vary with tire selection.

140M/140M AWD/160M/160M AWD Standard Equipment

Standard Equipment

Standard equipment may vary. Consult your Cat dealer for details.

POWER TRAIN

- Air cleaner, dual stage, dry type, diesel, with automatic engine derate and automatic dust ejector, service indicator through Cat Messenger
- Air-to-air after cooler (ATAAC)
- Belt, serpentine, automatic tensioner
- Brakes, oil disc, four-wheel, hydraulic
- Demand fan, hydraulic
- Differential Lock/Unlock, Automatic
- Drain, engine oil, ecology
- Electronic over speed protection
- Engine (140M) Cat C7 with ACERT Technology, diesel, with automatic engine derate and idle control
- Engine (140M AWD/160M/160M AWD) Cat C9 with ACERT Technology, diesel, with automatic engine derate and idle control

Note: Engines are Certified for Environment Canada Tier 3 standards.

- Engine Idle Shutdown (EIS)
- Fuel tank, 416 L (110 gal), ground level access and sediment drain
- Fuel-water separator
- Muffler, underhood
- Parking brake – multi-disc, sealed, oil-cooled
- Priming pump, fuel
- Rear axle, modular
- Sediment drain, fuel tank
- Tandem drive
- Transmission, 8F/6R, power shift, direct drive
- VHP Plus (Variable Horsepower Plus)

ELECTRICAL

- Alarm, back up
- Alternator, 80 ampere, sealed
- Batteries, maintenance free, heavy duty, 1,125 CCA
- Breaker panel, ground accessible
- Cab harness and electrical hydraulic valves
- Electrical system, 24V
- Grade Control Ready – Cab harness, software, electrical hydraulic valves, bosses and brackets
- Lights, roof-mounted roading, reversing, LED stop and tail
- Product Link Ready
- Starter, electric

OPERATOR ENVIRONMENT

- Accelerator
- Air conditioning with heater
- Arm and wrist rest, electronically adjustable
- Articulation, automatic Return-to-Center
- Cat Messenger operator information system
- Centershift pin indicator
- Coat hook
- Cup holder
- Display, digital speed and gear
- Doors, left and right side with wiper
- Gauge, machine level
- Gauge cluster (analog) – fuel, articulation, engine coolant temp, engine RPM, hydraulic oil temp
- Hour meter, digital
- Joystick hydraulic controls right/left blade lift with float position, circle drive, blade sideshift and tip, centershift, front wheel lean, articulation and steering
- Joystick, adjustable armrests
- Joystick gear selection
- Joystick hydraulic power steering
- Ladders, cab, left and right side
- Lights, night time cab
- Mirror, inside rearview, wide angle
- Power port, 12V
- Radio Ready, Entertainment
- ROPS cab, sound suppressed
- Seat, cloth-covered, comfort suspension
- Seat belt, retractable 76 mm (3 in)
- Storage area for cooler/lunchbox
- Throttle control, electronic
- Windows, laminated glass:
 - fixed front with intermittent wiper
 - side and rear (3)

FLUIDS

- Antifreeze
- Extended Life Coolant to -35°C (-30°F)

TIRES, RIMS AND WHEELS

- Partial allowance for tires on 254×607 mm (10×24 in) multi-piece rims is included in the base machine price and weight

OTHER STANDARD EQUIPMENT

- Anti-glare paint
- Brake accumulators
- Bumper, rear, integrated with hitch
- CD ROM Parts Book
- Clutch, circle drive slip
- Cutting edges
 - 152×16 mm ($6 \times 5/8$ in)
 - curved DH-2 steel
 - 19 mm (3/4 in) mounting bolts
- Doors (3), engine compartment, locking
- Drawbar – 6 shoes, replaceable wear strips
- Electrical hydraulic valves, hydraulic lines for base 8 functions
- Endbits
 - 16 mm (5/8 in) DH-2 steel
 - 19 mm (3/4 in) mounting bolts
- Fluid check, ground level
- Frame, articulated, with safety lock
- Ground level engine shutdown
- Ground level fueling
- Hammer (emergency exit)
- Horn, electric
- Hydraulic lines for base functions
- Lockout, hydraulic implement (for roading and servicing)
- Moldboard – $3658 \times 610 \times 22$ mm ($12 \text{ ft} \times 24 \text{ in} \times 7/8 \text{ in}$)
- Mounting, cab roof accessories
- Pump, hydraulic, high capacity, 98 cm^3 (6 in^3)
- Radiator, cleanout access
- Secondary steering
- Serviceability, left-hand side
- S•O•SSM ports: engine, hydraulic, transmission, coolant, fuel
- Tandem walkway/guards
- Tool box
- Tow hitch

140M/140M AWD/160M/160M AWD Optional Equipment

Optional Equipment

Optional equipment may vary. Consult your Cat dealer for details.

	kg	lb
ELECTRICAL		
Alternator, 150 ampere	2	5
Batteries:		
extreme duty, 1,400 CCA	14	30
Converter, communication (CB)	5	11
Lights:		
Headlights, high	5	11
Headlights, low	5	11
Working lights, basic	9	20
Working lights, plus	10	22
Warning: beacon or strobe	2	5
Mounting for warning light	5	11

GUARDS

Articulation guard	13	30
Axle hose guard	7	15
Fenders, front	56	123
Fenders, rear	156	344
Sound guard (bottom)	110	243
Transmission guard	141	311

OPERATOR ENVIRONMENT

Bluetooth		
Fan, defroster, rear window	2	4
Mirrors, outside:		
heated 24V mounted	15	33
Precleaner, HVAC	5	10
Radio ready, AM/FM	9	20
Seat, air suspension, cloth	2	5
Shade, sun	2	5
Wiper/washer, rear	2	4

	kg	lb
POWER TRAIN		
Precleaner, snow/debris	2	4.4
Transmission, autoshift	2	5

OTHER ATTACHMENTS

AccuGrade ARO	39	85
Accumulators, blade lift	77	170
Camera, rearview	9	20
Cat Grade Control Cross Slope	75	165
Cat Product Link 321 (Satellite)	13	29
Cat Product Link 522 (Cellular)	13	29
Compressor/tank, air	27	50
Heater, engine coolant:		
120V	1	3
240V	1	3
Hydraulic arrangements with one or more additional hydraulic valves are available for ripper, dozer, snow wings, front lift group, mid-mount scarifier.		
Security system	5	11
Snow wing mounting, frame ready	111	245
Sound suppression	15	33
Starting aid, ether	0.5	1

	kg	lb
WORK TOOLS/ GROUND ENGAGING TOOLS		
Blade extension, left hand, 610 mm (2 ft)	113	249
Endbits, overlay	24	52
Front lift group, mounting	5	11
Front lift group	680	1,500
Mid-Mount Scarifier, Package	942	2,077
Mid-Mount Scarifier, Mounting	57	125
Moldboard		
4267 × 610 × 22 mm (14 ft × 24 in × 7/8 in)	100	220
4267 × 686 × 25 mm (14 ft × 27 in × 1 in)	257	567
160M/160M AWD only: 4877 × 686 × 25 mm (16 ft × 27 in × 1 in)	472	1,041
Push plate	885	1,950
Ripper, mounting	32	70
Ripper, rear	962	2,120
Ripper tooth	28	61
Scarifier, front	434	956

MACHINE ARRANGEMENTS

Snow Arrangement

For more complete information on Cat products, dealer services, and industry solutions, visit us on the web at www.cat.com

AEHQ7004 (04-2013)
(Canada)

© 2013 Caterpillar Inc.
All rights reserved

Materials and specifications are subject to change without notice. Featured machines in photos may include additional equipment. See your Cat dealer for available options.

CAT, CATERPILLAR, SAFETY.CAT.COM, their respective logos, "Caterpillar Yellow" and the "Power Edge" trade dress, as well as corporate and product identity used herein, are trademarks of Caterpillar and may not be used without permission.



Courtesy of Machine.Market