



Cat[®] 279D

COMPACT TRACK LOADER

FEATURES:

The Cat[®] 279D Compact Track Loader, with its radial lift design, delivers impressive mid-lift reach and excellent digging performance with outstanding drawbar power. Its standard, suspended undercarriage system provides superior traction, flotation, stability and speed to work in a wide range of applications and underfoot conditions. The 279D features the following:

- **Industry leading sealed and pressurized cab option** provides a cleaner and quieter operating environment with excellent work tool visibility.
- **Available high-back, heated, air ride seat with seat mounted adjustable joystick controls** makes the D Series the industry leader in operator comfort.
- **High performance power train** provides maximum performance and production capability through the Electronic Torque Management system, standard two speed travel and an electronic hand/foot throttle with decel pedal capability.
- **High Flow XPS hydraulic system** is available for applications that demand maximum hydraulic work tool performance.
- **Electronically controlled Cat C3.3B engine** provides high horsepower and torque while meeting U.S. EPA Tier 4 Final (EU Stage IIIB) emission standards.
- **Cat "Intelligent Leveling" system (ILEV)** provides industry leading technology, integration and optional features such as dual direction self level, work tool return to dig and work tool positioner.
- **Standard fully independent torsion axle suspension** combined with the optional Speed Sensitive Ride Control system improves operation on rough terrain, enabling better load retention, increased productivity and greater operator comfort.
- **Maximize machine capability and control** with optional Advanced Display providing on-screen adjustments for implement response, hystat response and creep control. Also features multi-language functionality with customizable layouts, security system and rearview camera.
- **Ground level access** to all daily service and routine maintenance points helps reduce machine downtime for greater productivity.
- **Broad range of performance matched Cat Work Tools** make the Cat Compact Track Loader the most versatile machine on the job site.

Specifications

Engine

Engine Model	Cat C3.3B DIT (turbo)	
Gross Power SAE J1995	55.4 kW	74.3 hp
Net Power SAE 1349	54.4 kW	72.9 hp
Net Power ISO 9249	54.9 kW	73.7 hp
Peak Torque at 1,500 rpm SAE J1995	265 N-m	195 lbf-ft
Displacement	3.3 L	203 in ³
Stroke	120 mm	4.7 in
Bore	94 mm	3.7 in

Weights*

Operating Weight	4487 kg	9,893 lb
------------------	---------	----------

Power Train

Travel Speed (Forward or Reverse):		
One Speed	7.2 km/h	4.5 mph
Two Speed	11.3 km/h	7.0 mph

*Operating Weight, Operating Specifications and Dimensions all based on 75 kg (165 lb) operator, all fluids, two speed, OROPS, 1981 mm (78 in) dirt bucket, 400 mm (15.7 in) tracks, dual flange front idler/single flange rear idler, standard flow hydraulics, mechanical suspension seat, no optional counterweights and manual quick coupler (unless otherwise noted).

Hydraulic System

Hydraulic Flow – Standard:			
Loader Hydraulic Pressure	23 000 kPa	3,335 psi	
Loader Hydraulic Flow	86 L/min	23 gal/min	
Hydraulic Power (calculated)	33 kW	44 hp	
Hydraulic Flow – High Flow XPS:			
Maximum Loader Hydraulic Pressure	28 000 kPa	4,061 psi	
Maximum Loader Hydraulic Flow	121 L/min	32 gal/min	
Hydraulic Power (calculated)	57 kW	76 hp	

Operating Specifications*

Rated Operating Capacity:			
35% Tipping Load	932 kg	2,055 lb	
50% Tipping Load	1331 kg	2,935 lb	
Rated Operating Capacity with Optional Counterweight			
Tipping Load	1444 kg	3,185 lb	
Breakout Force, Tilt Cylinder	2663 kg	5,870 lb	
Breakout Force, Tilt Cylinder	3304 kg	7,285 lb	
Ground Contact Area (400 mm/15.7 in track)	1.30 m ²	2,015 in ²	
Ground Contact Area (450 mm/17.7 in track)	1.47 m ²	2,272 in ²	
Ground Pressure (400 mm/15.7 in track)	33.9 kPa	4.9 psi	
Ground Pressure (450 mm/17.7 in track)	30.0 kPa	4.4 psi	



279D Compact Track Loader

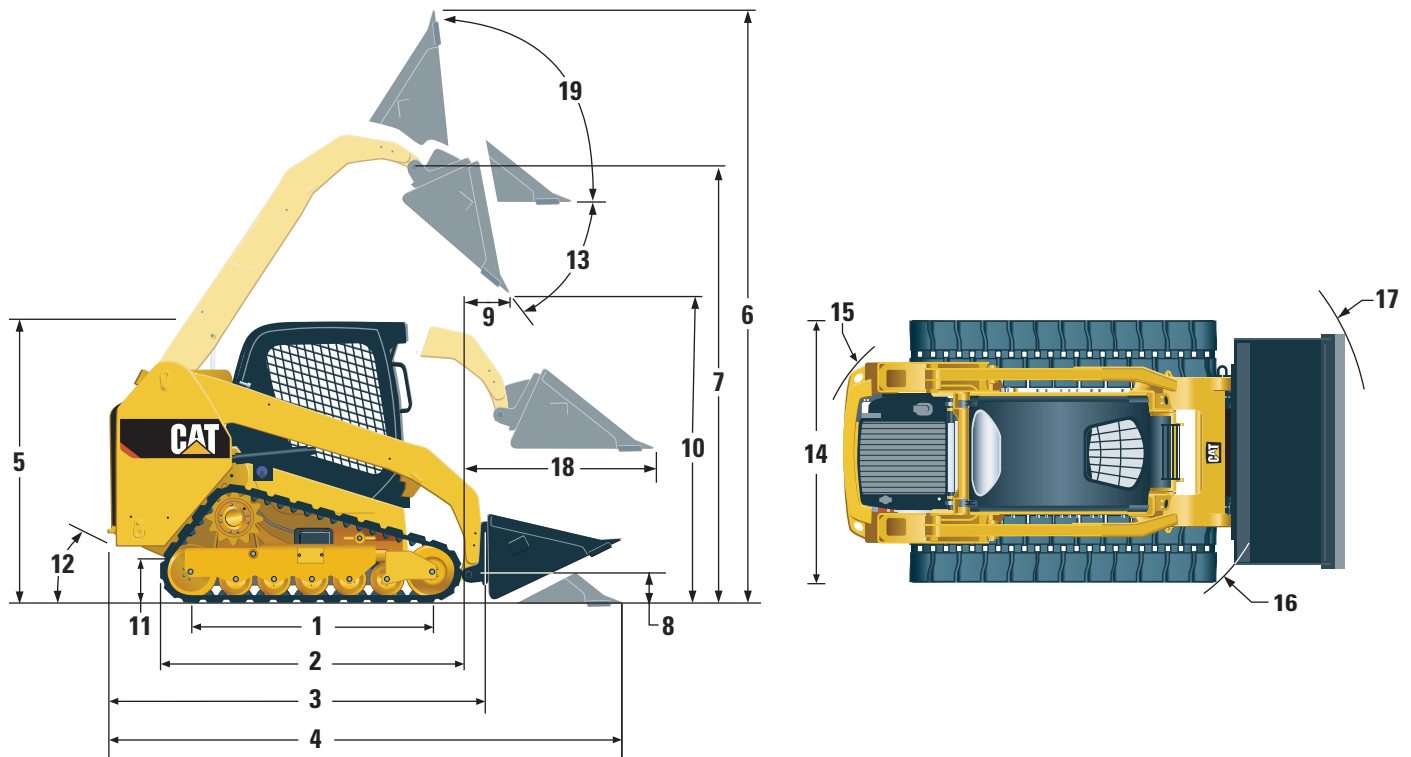

Dimensions*

1	Length of Track on Ground	1630 mm	64.2 in
2	Overall Length of Track	2129 mm	83.8 in
3	Length without Bucket	2995 mm	117.9 in
4	Length with Bucket on Ground	3714 mm	146.2 in
5	Height to Top of Cab	2113 mm	83.2 in
6	Maximum Overall Height	4051 mm	159.5 in
7	Bucket Pin Height at Maximum Lift	3173 mm	124.9 in
8	Bucket Pin Height at Carry Position	198 mm	7.8 in
9	Reach at Maximum Lift and Dump	575 mm	22.6 in
10	Clearance at Maximum Lift and Dump	2485 mm	97.8 in
11	Ground Clearance	226 mm	8.9 in
12	Departure Angle		32°
13	Maximum Dump Angle		39°
14	Vehicle Width (400 mm/15.7 in tracks)	1931 mm	76.0 in
	Vehicle Width (450 mm/17.7 in tracks)	1981 mm	78.0 in
15	Turning Radius from Center – Machine Rear	1796 mm	70.7 in
16	Turning Radius from Center – Coupler	1410 mm	55.5 in
17	Turning Radius from Center – Bucket	2256 mm	88.8 in
18	Maximum Reach with Arms Parallel to Ground	1373 mm	54.0 in
19	Rack Back Angle at Maximum Height		84°

Cab

ROPS	ISO 3471:2008
FOPS	ISO 3449:2005 Level I
FOPS Level II	ISO 3449:2005 Level II

Service Refill Capacities

Cooling System	14 L	3.7 gal
Engine Crankcase	11 L	3.0 gal
Fuel Tank	94 L	24.8 gal
Hydraulic System	52 L	13.7 gal
Hydraulic Tank	39 L	10.3 gal

MANDATORY EQUIPMENT

- Hydraulics, Standard or High Flow XPS
- Quick Coupler, Mechanical or Electric
- Seat Belt, 50 mm (2 in) or 75 mm (3 in)
- Steel Imbed Rubber Track – 400 mm (15.7 in) or 450 mm (17.7 in)
- Dual Flange Front Idler/Single Flange Rear Idler or Triple Flange Front/Rear Idlers

PERFORMANCE PACKAGES

- Performance Package H1: *Standard Flow Hydraulics (No Self Level)*
- Performance Package H2: *Standard Flow Hydraulics, Dual Direction Electronic Self Level (Raise and Lower), Electronic Snubbing (Raise and Lower)*
- Performance Package H3: *High Flow XPS, Dual Direction Electronic Self Level (Raise and Lower), Electronic Snubbing (Raise and Lower)*

STANDARD EQUIPMENT

ELECTRICAL

- 12 volt Electrical System
- 80 ampere Alternator
- Ignition Key Start/Stop Switch
- Lights: *Gauge Backlighting, Two Rear Tail Lights, Two Rear Halogen Working Lights, Two Adjustable Front Halogen Lights, Dome Light*
- Backup Alarm
- Heavy Duty Battery, 880 CCA

OPERATOR ENVIRONMENT

- Gauges: *Fuel Level, Hour Meter*
- Operator Warning System Indicators: *Air Filter Restriction, Alternator Output, Armrest Raised/Operator Out of Seat, Engine Coolant Temperature, Engine Oil Pressure, Glow Plug Activation, Hydraulic Filter Restriction, Hydraulic Oil Temperature, Park Brake Engaged, Engine Emission System*
- Adjustable Vinyl Seat
- Fold In Ergonomic Contoured Armrest
- Control Interlock System, when operator leaves seat or armrest raised: *Hydraulic System Disables, Hydrostatic Transmission Disables, Parking Brake Engages*
- ROPS Cab, Open, Tilt Up
- FOPS, Level I
- Top and Rear Windows
- Floor Mat
- Interior Rearview Mirror
- 12 volt Electric Socket
- Horn
- Hand (Dial) Throttle, Electronic
- Adjustable Joystick Controls
- Anti-theft Security System with 6-button Keypad
- Storage Compartment with Netting

OPTIONAL EQUIPMENT

- Hand-Foot Style Controls
- External Counterweights
- Beacon, Rotating
- Engine Block Heater – 120V
- Oil, Hydraulic, Cold Operation
- Paint, Custom
- Heavy Duty Battery, 1,000 CCA
- Product Link™, Cellular

COMFORT PACKAGES

- Open ROPS (C0): *Static Seat (No Foot Throttle, Headliner, Heater or Door)*
- Open ROPS (C1): *Foot Throttle, Headliner, Cup Holder, and choice of Seat (Mechanical Suspension or High Back, Heated, Air Ride Seat) (No Heater or Door)*
- Enclosed ROPS with Heater (C2): *Foot Throttle, Headliner, Heater and Defroster, Side Windows, Cup Holder, Radio Ready, choice of Seat (Mechanical Suspension or High Back, Heated, Air Ride Seat) and Door (Glass or Polycarbonate)*
- Enclosed ROPS with A/C (C3): *C2 + Air Conditioner*

POWER TRAIN

- Cat C3.3B, Turbo Diesel Engine, Meeting U.S. EPA Tier 4 Final (EU Stage IIIB) Emission Standards
- Air Cleaner, Dual Element, Radial Seal
- S-O-SSM Sampling Valve, Hydraulic Oil
- Filters, Cartridge-type, Hydraulic
- Filters, Cartridge-type, Fuel and Water Separator
- Radiator/Hydraulic Oil Cooler (side-by-side)
- Spring Applied, Hydraulically Released, Wet Multi Disc Parking Brakes
- Hydrostatic Transmission, Two Speed Travel
- Suspension – Independent Torsion Axles (4)

OTHER

- Engine Enclosure, Lockable
- Extended Life Antifreeze, –37° C (–34° F)
- Machine Tie Down Points (6)
- Support, Lift Arm
- Hydraulic Oil Level Sight Gauge
- Radiator Coolant Level Sight Gauge
- Radiator, Expansion Bottle
- Cat ToughGuard™ Hose
- Auxiliary, Hydraulics, Continuous Flow
- Heavy Duty, Flat Faced Quick Disconnects with Integrated Pressure Release
- Split D-Ring to Route Work Tool Hoses Along Side of Left Lift Arm
- Electrical Outlet, Beacon
- Belly Pan Cleanout
- Variable Speed Demand Fan

- Speed Sensitive Ride Control
- Advanced Display: Full Color, 5 in LCD screen, Advanced Multi-operator Security System, On-screen Adjustments for Implement Response, Hystat Response, and Creep Control; Rearview Camera Ready
- Advanced Display: Rearview Camera Included
- Work Tool Return to Dig and Work Tool Positioner
- Bluetooth Radio with Microphone (AM/FM/Weather Band Receiver with USB and Auxiliary Input Jack)

279D Compact Track Loader

For more complete information on Cat products, dealer services, and industry solutions, visit us on the web at www.cat.com

© 2016 Caterpillar
All rights reserved

Materials and specifications are subject to change without notice. Featured machines in photos may include additional equipment. See your Cat dealer for available options.

CAT, CATERPILLAR, SAFETY.CAT.COM, their respective logos, "Caterpillar Yellow" and the "Power Edge" trade dress, as well as corporate and product identity used herein, are trademarks of Caterpillar and may not be used without permission.

AEHQ7011-02 (05-2016)
Replaces AEHQ7011-01
(NACD, EU)



Courtesy of Machine.Market