

# 320C Material Handler

## Working Range/Lift Chart – Two-Piece Front

Machine equipped with 12.4 m (40'8") Cat two-piece MH front.

Maximum horizontal reach	12.4 m	40'8"
Maximum height at 9.75 m (32')	13.7 m	44'11"

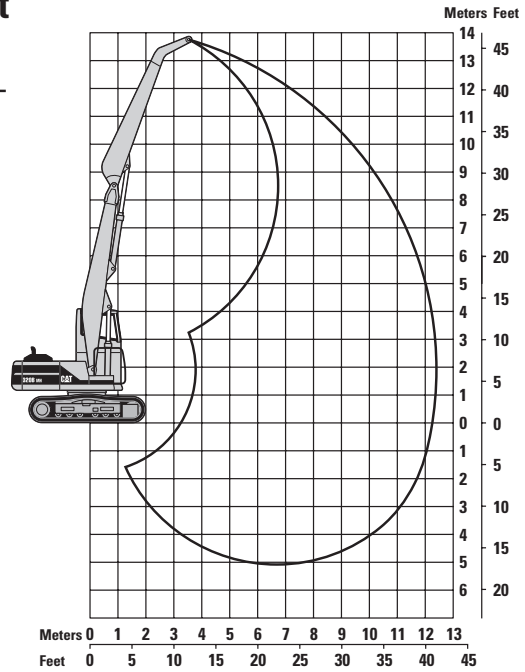

## Shipping Dimensions

All dimensions are approximate.

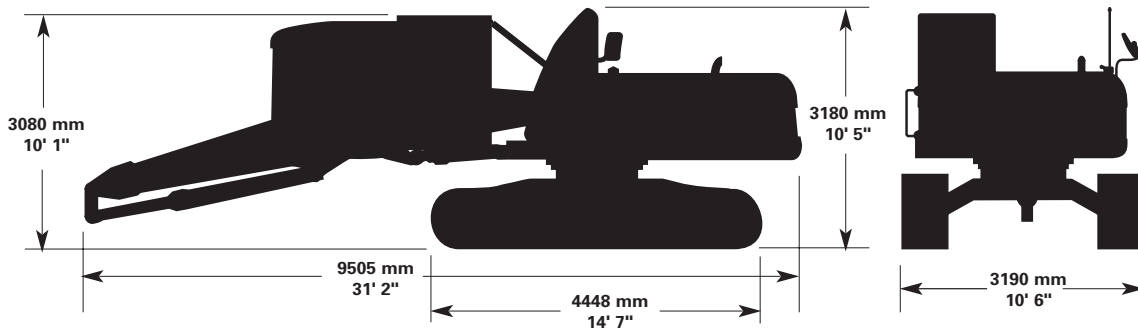

## Track

Purpose built, track-type undercarriage unique to material handlers.

Number of shoes, each side	49
Number of rollers, each side	8
Overall track length	4455 mm (14'7")
Gauge	2590 mm (8'6")
Track shoes	
Triple grouser	600 mm (24")
Ground clearance	630 mm (25")

## Features

- robot-welded, pentagonal track roller frames with hydraulic adjusters
- sealed and lubricated rollers and idlers
- sealed track with triple-grouser shoes

## Weights

	kg	lb
Operating weight	25 530	56,280
Counterweight	5820	12,800
Stick	1020	2,250
Boom*	2650	5,835

\* Includes boom and stick cylinders

## Performance\*

	km/h	mph
Low range travel speed	0-2.6	0-1.6
High range travel speed	0-4.3	0-2.7
	kN	lb
Drawbar pull	236	53,055

\*Values at maximum pump displacement

# 320C Material Handler

## Lift Capacities

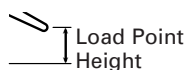





















Load at  
Maximum Reach



Load Radius  
Over Front



Load Radius  
Over Side

		1.5 m/5.0 ft		3.0 m/10.0 ft		4.5 m/15.0 ft		6.0 m/20.0 ft		7.5 m/25.0 ft		9.0 m/30.0 ft		10.5 m/35.0 ft		12.0 m/40.0 ft				m ft
																				
10.5 m 35.0 ft	kg lb									*6000 *13,250	5500 11,700							*3900 *8650	*3900 *8650	8.96 28.84
9.0 m 30.0 ft	kg lb									*5800 *12,700	5550 11,900	*5350 *11,750	4100 8800					*3500 *7750	3250 7300	10.20 33.14
7.5 m 25.0 ft	kg lb									*5800 *12,650	5550 11,900	*5300 *11,600	4150 8850	4400 9400	3150 6750			*3300 *7250	2850 6300	11.11 36.23
6.0 m 20.0 ft	kg lb							*6700 *14,550	*6700 *14,550	*6000 *13,000	5450 11,700	*5400 *11,750	4050 8750	4400 9400	3150 6750			*3200 *7000	2600 5700	11.75 38.43
4.5 m 15.0 ft	kg lb							*7300 *15,850	*7300 *15,850	*6300 *13,700	5250 11,350	5500 11,850	3950 8500	4350 9300	3100 6650	3500 7700	2500 5450	*3150 *6900	2400 5300	12.17 39.88
3.0 m 10.0 ft	kg lb					*10 250 *22,200	*10 250 *22,200	*8050 *17,450	7050 15,150	*6700 *14,500	5050 10,850	5400 11,550	3850 8250	4250 9150	3050 6500	3450 7450	2450 5250	*3150 *6900	2300 5100	12.40 40.66
1.5 m 5.0 ft	kg lb					*11,700 *25,300	10 100 21,750	*8750 *18,900	6650 14,250	6850 14,700	4800 10,350	5250 11,250	3700 7950	4200 8950	2950 6350	3450 7350	2400 5150	*3200 *7050	2300 5000	12.44 40.81
Ground Line	kg lb					*12,250 *26,550	9400 20,250	*9000 *19,500	6250 13,500	6600 14,200	4600 9900	5100 10,950	3600 7700	4100 8800	2900 6200	3400 7300	2400 5100	*3200 *7000	2300 5050	12.30 40.34
-1.5 m -5.0 ft	kg lb	*1850 *4100	*1850 *4100	*3750 *8550	*3750 *8550	*9600 *22,300	9050 19,400	*8750 *18,900	6000 12,950	6450 13,850	4450 9600	5000 10,750	3500 7500	4050 8700	2850 6100			*2800 *6100	2400 5250	11.96 39.22
-3.0 m -10.0 ft	kg lb			*4900 *11,000	*4900 *11,000	*9400 *21,600	8900 19,100	*7800 *16,850	5900 12,700	*6150 *13,200	4350 9400	*4800 *10,250	3450 7400	*3500 *7250	2800 6050			*2900 *6400	2650 5850	11.03 36.05
-4.5 m -15.0 ft	kg lb							*6200 *13,250	5900 12,700	*4850 *10,300	4350 9400							*3700 *8400	3550 8000	8.84 28.37

\* Indicates that the load is limited by hydraulic capacity rather than tipping capacity. Lift capacity ratings are based on SAE standard J1097. Rated loads do not exceed 87% of hydraulic lifting capacity or 75% of tipping capacity.