

# 320D

## Hydraulic Excavator



### Engine

Engine Model	Cat® C6.4 ACERT™	
Net Flywheel Power	103 kW	138 hp

### Weights

Operating Weight – Std. Undercarriage	21 450 kg	47,290 lb
--	-----------	-----------

- Heavy Duty Reach boom, R2.9B1 (9 ft 6 in) Reinforced Stick, 0.9 m<sup>3</sup> (1.2 yd<sup>3</sup>) General Purpose Bucket, 800 mm (32 in) Shoes

# 320D Hydraulic Excavator

*The D Series incorporates innovations for improved performance and versatility.*

---

## Engine and Hydraulics

- ✓ ACERT™ Technology works at the point of combustion to optimize engine performance and provide low exhaust emissions with exceptional performance capabilities and proven reliability. By combining excellent fuel efficiency and maximized production, 320D will provide unmatched profit potential. **pg. 4**

---

## Complete Customer Support

Your Cat® dealer offers a wide range of services that can be set up under a customer support agreement when you purchase your equipment. The dealer will help you choose a plan that can cover everything from machine configuration to eventual replacement. **pg. 11**

---

## Structures

Caterpillar® design and manufacturing techniques assure outstanding durability and service life from these important components. **pg. 5**

---

## Cat® 320D Total Solutions

With Caterpillar and it's extensive dealer network, we offer a wide variety of solutions to the issues you face daily. **pg. 12**

---

## Operator Station

- ✓ Provides maximum space, wider visibility and easy access to switches. The monitor is a full-color graphical display that allows the operator to understand the machine information easily. Overall, the new cab provides a comfortable environment for the operator. **pg. 6**



---

### Booms and Sticks

The 320D offers the most comprehensive choice of front linkage options and attachments to best meet your job and application. **pg. 8**

---

### Work Tools – Attachments

✓ A variety of work tools, including buckets, couplers, hammers, and shears are available through Cat® Work Tools. **pg. 9**

---

### Service and Maintenance

Fast, easy service has been designed in with extended service intervals, advanced filtration, convenient filter access and user-friendly electronic diagnostics for increased productivity and reduced maintenance costs. **pg. 10**



✓ *New Feature*

## Engine and Hydraulics

*The Cat® 320D delivers the power and control that you need in order to get the job done quickly and efficiently in all applications.*



**Cat C6.4.** The Cat C6.4 with ACERT™ Technology introduces a series of evolutionary, incremental improvements that provide breakthrough engine technology. The building blocks of ACERT Technology are fuel delivery, air management and electronic control. ACERT Technology optimizes engine performance while meeting global low emission regulations. With its proven technology, robust components and precision manufacturing, you can count on this engine to power up at start time and keep working productively all shift long.

### **Automatic Engine Speed Control.**

Automatic Engine Control with convenient one-touch command. During no-load or light-load conditions, the Automatic Engine Speed reduces engine speed. This maximizes fuel efficiency and reduces sound levels.

**Air Cleaner.** The radial seal air filter features a double-layered filter core for more efficient filtration and is located in a compartment behind the cab. A warning is displayed on the monitor when dust accumulates above a preset level.

**Low sound, low vibration.** By design, the Cat C6.4 improves operator comfort by reducing sound and vibration.

**Hydraulic System.** The hydraulic system pressure has been increased to 35,000 kPa, attributing to the following performance enhancements:

- 5% greater stick and bucket forces to handle those tough digging applications.
- Increased drawbar pull to 206 kN, gives you better ability to travel up slopes, better spot turning capability and more tractive effort.

**Component Layout.** The 320D hydraulic system and component locations have been designed to provide a high level of system efficiency. The main pumps, control valves and hydraulic tank are located close together to allow for shorter tubes and lines between components, which reduce friction loss, and pressure drops in the lines. The layout further provides greater operator comfort by placing the radiator on the cab side of the upper structure. This allows incoming air to enter the engine compartment from the operator side and hot air and corresponding engine sound to exit on the opposite side away from the operator. This reduces engine compartment heat and sound being transmitted to the operator.

**Pilot System.** The pilot pump is independent from the main pumps and controls the front linkage, swing and travel operations.

### **Hydraulic Cross Sensing System.**

The hydraulic cross sensing system utilizes each of two hydraulic pumps to 100 percent of engine power, under all operating conditions. This improves productivity with faster implement speeds and quicker, stronger pivot turns.

**Auxiliary Hydraulic Valve.** The auxiliary valve is standard on the 320D. Control Circuits are available as attachments, allowing for operation of high and medium pressure tools such as shears, grapples, hammers, pulverizers, multi-processors and vibratory plate compactors.

### **Boom and Stick Regeneration Circuit.**

Boom and stick regeneration circuit saves energy during boom-down and stick-in operation which increases efficiency, reduces cycle times and pressure loss for higher productivity, lower operating costs and increased fuel efficiency.

**Hydraulic Cylinder Snubbers.** Snubbers are located at the rod-end of the boom cylinders and both ends of the stick cylinders to cushion shocks while reducing sound levels and extending component life.

## Structures

*Caterpillar® excavators are designed to handle the most rugged operating conditions while providing long life and value.*

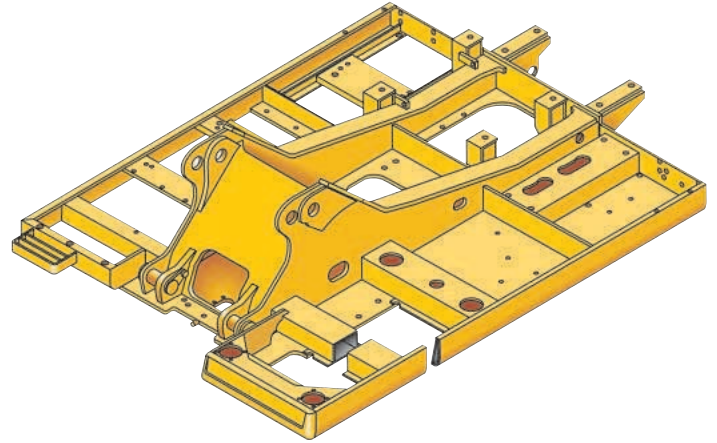
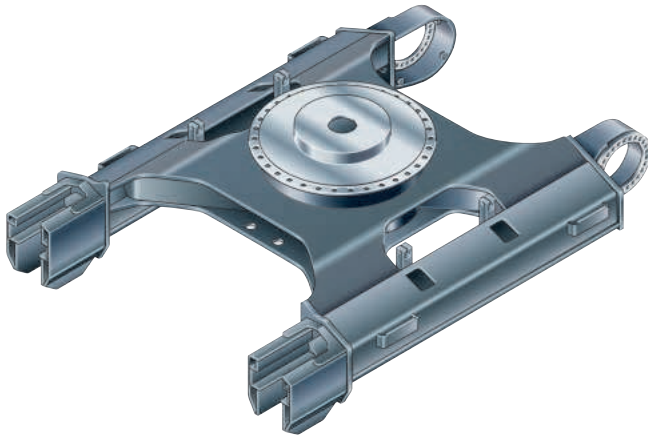

**Carbody Design and Track Roller Frames.** X-shaped, box-section carbody provides excellent resistance to torsional bending. Robot-welded track roller frames are press-formed, pentagonal units to deliver exceptional strength and service life.

**Main Frame.** The main frame utilizes high-tensile strength steel and one-piece swing table, which improves strength and reliability.

**Undercarriage.** Durable Cat undercarriage absorbs stresses and provides excellent stability.

**Rollers and Idlers.** Sealed and lubricated track rollers, carrier rollers, and idlers provide excellent service life, to keep the machine in the field longer.

**Standard Undercarriage.** The standard undercarriage is well suited for applications that require frequent repositioning of the machine, have restricted working space or uneven, rocky terrain.

## Operator Station

*Designed for comfort, simple and easy operation, the 320D allows the operator to focus on production.*



**Operator Station.** The workstation is spacious, quiet and comfortable, assuring high productivity during a long work day. The air conditioner and attachment switches are conveniently located on the right-hand wall, and the key switch and throttle dial are on the right-hand console. The monitor is easy to see and maximizes visibility.

**Standard Cab Equipment.** To enhance operator comfort and productivity, the cab includes a lighter; drink holder, coat hook, service meter, literature holder, magazine rack and storage compartment.



**Monitor.** The monitor is a full color 400x234 pixels Liquid Crystal Display (LCD) graphic display. The monitor angle can be adjusted to minimize sun glare and has the capability of displaying information in Indonesian and twenty-six other languages.

The Master Caution Lamp blinks ON and OFF when one of the critical conditions below occurs:

- Engine oil pressure low
- Coolant temperature high
- Hydraulic oil temperature high

Under normal conditions or the default condition, the monitor display screen is divided into four areas; clock and throttle dial, gauge, event display and multi-information display.

**Clock and Throttle Dial Display.**

The clock and throttle dial position are displayed in this area. When Economy mode is activated, the icon of the gas station icon will be indicated at the side of the throttle dial.

**Gauge Display.** Three analog gauges, fuel level, hydraulic oil temperature and coolant temperature, are displayed in this area.

**Event Display.** Machine information is displayed in this area with the icon and language.

**Multi-information Display.** This area is reserved for displaying various information that is convenient for the operator. The “CAT” logo mark is displayed when no information is available to be displayed.

**Joystick Control.** Joystick controls have low lever effort and are designed to match the operator’s natural wrist and arm position. The operator can operate joystick controls with an arm on the armrest and the horizontal and vertical strokes have been designed to reduce operator fatigue.

**Seat.** A new suspension seat provides a variety of adjustments to suit the operator’s size and weight including fore/aft, height and weight. Wide adjustable armrests and a retractable seat belt are also included.

**Hydraulic Activation Control Lever.** For added safety, this lever must be in the operate position to activate the machine control functions.

**Climate Control.** Positive filtered ventilation with a pressurized cab is standard. Fresh air or re-circulated air can be selected with a switch on the left console.



**Console.** Redesigned consoles feature a simple, functional design to reduce operator fatigue, ease of switch operation and excellent visibility. Both consoles have attached armrests with height adjustments.

**Cab Exterior.** The exterior design uses thick steel tubing along the bottom perimeter of the cab, improving the resistance of fatigue and vibration. This design allows the FOGS to be bolted directly to the cab, at the factory or as an attachment later, enabling the machine to meet specifications and job site requirements.

**Cab Mounts.** The cab shell is attached to the frame with viscous rubber cab mounts, which dampen vibrations and sound levels while enhancing operator comfort.

**Windows.** To maximize visibility, all glass is affixed directly to the cab, eliminating window frames. The upper front windshield opens, closes and stores on the roof above the operator with a one-touch action release system.

**Wipers.** Pillar-mounted wipers increase the operator’s viewing area and offer continuous and intermittent modes.

**Skylight.** An enlarged skylight with sunshade provides excellent visibility and excellent ventilation.

**Product Link.** Product Link is now an attachment available from the factory.

## Booms and Sticks

*Designed-in flexibility to help bring higher production and efficiency to all jobs.*

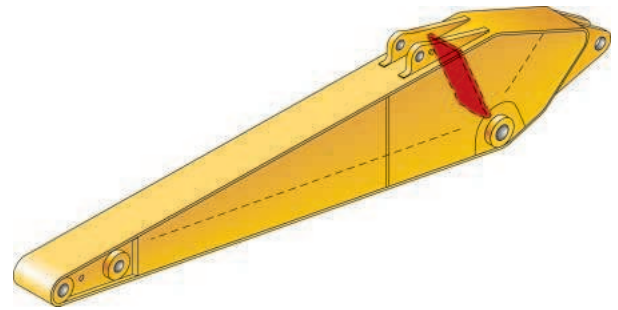
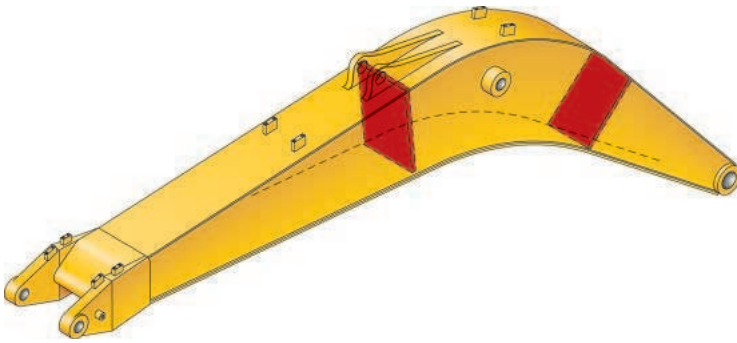

### **Booms, Sticks and Attachments.**

Designed for maximum flexibility, productivity and high efficiency on all jobs, the 320D offers a wide range of configurations suitable for a variety of applications.

**Caterpillar Booms.** Caterpillar booms have large cross-sections and internal baffle plates to provide long life durability.

**Caterpillar Sticks.** Caterpillar sticks are made of high-tensile strength steel using a large box section design with interior baffle plates and an additional bottom guard.

**Heavy Duty Reach Boom.** The reach boom features an optimum design that maximizes digging envelopes with the R2.9B1 stick. Heavy duty reach boom provides additional strength and is recommended for tough applications.

- The B1-family bucket associated with this stick has enough capacity for excellent reach and depth in trenching and general construction applications.

### **R2.9B1 Reinforced Stick**

- This stick provides the most versatile front linkage. The stick is a good fit for all 11 ton dump trucks with regard to reach and bucket capacity and delivers good stability.

### **R2.5B1 Heavy Duty Stick**

- This stick has thicker plates and is used for heavy-duty applications.

**Linkage Pins.** All the pins in the front linkages have thick chrome plating, giving them high wear and corrosion resistance.

**Bucket Linkage.** The power link improves durability, increases machine-lifting capability in key lifting positions and is easier to use than compared to the previous lifting eye.



## Work Tools – Attachments

*The 320D has an extensive selection of work tools to optimize machine performance.*

**Service Life.** Caterpillar buckets increase service life and reduce repair costs.

- Dual radius design for increased heel clearance and reduced wear
- Robot welding of hinge assembly for increased weld penetration and longer life
- Incorporates the new aggressive and easier to install, K Series™ GET tool system
- High strength and heat-treated steel that exceeds T-1 in high wear areas

**General Purpose Bucket (GP).** General purpose (GP) bucket for digging in low-impact, moderately abrasive materials such as dirt, loam, gravel and clay.

**Heavy-Duty Buckets.** Heavy-duty (HD) buckets are used for a wide range of moderately abrasive applications such as mixed dirt, clay and rock. HD buckets have best loading and dumping characteristics and will empty easier in cohesive material. More robust construction than the GP buckets.

### **Heavy-Duty Power (HDP) Buckets.**

For use in moderately abrasive applications where breakout force and cycle times are critical. Maximizes tip force and improves cycle times in most materials. Not for use in sticky material conditions. Cutting edge and GET are up-sized.

**Heavy-Duty Rock Buckets.** Heavy-duty rock for aggressive bucket loading in highly abrasive application such as shot rock and granite. Features include:

- Thickest wear plates to extend the life of bucket in severe applications
- Side wear plated extend further up the side of the bucket for maximum protection in rocky soils
- Buckets accept sidebar protectors for best sidebar protection, or sidecutters for best fill characteristics and bucket wear protection



### **Caterpillar Ground Engaging Tools (GET).**

The new Caterpillar K Series™ GET is featured on the new buckets. This new GET system uses a hammerless vertical retainer, which is easier to remove and install than the Cat J Series pin. The new tooth shapes are more aggressive and offer better penetration than the previous generation of tips. There are also a variety of side cutters and sidebar protectors to match operating conditions.

**Tool Control System.** The optional tool control system maximizes work tool productivity by configuring hydraulic flow, pressure, and operator controls to match a specific work tool. System versatility enables a wide range of tools to be used.

### **Pin-Grabber Plus Quick Coupler.**

Pin-Grabber Plus Quick Couplers multiply the versatility and utility of Cat Excavators by allowing them to pick up and use virtually any work tool equipped with standard pins.

**Dedicated Quick Coupler.** Quick Couplers increase the versatility of Cat excavators; allowing the ease of changing work tools to meet job requirements at hand in a matter of minutes or seconds. Dedicated quick coupler buckets have no loss of tip radius, and develop maximum breakout force.

## Service and Maintenance

*Simplified service and maintenance features save you time and money.*



**Ground Level Service.** The design and layout of the 320D was made with the service technician in mind. Many service locations are easily accessible at ground level allowing critical maintenance to get done quickly and efficiently.

**Air Filter Compartment.** The air filter features a double-element construction for superior cleaning efficiency. When the air cleaner plugs, a warning is displayed on the monitor screen inside the cab.

**Pump Compartment.** A service door on the right side of the upper structure allows ground-level access to the pump and pilot filter.

**Radiator Compartment.** The left rear service door allows easy access to the engine radiator, oil cooler and air-to-air-after-cooler. A reserve tank and drain cock are attached to the radiator for simplified maintenance.

**Capsule Filter.** The hydraulic return filter, a capsule filter, is situated outside the hydraulic tank. This filter prevents contaminants from entering the system when hydraulic oil is changed and keeps the operation clean.

**Greasing Points.** A concentrated remote greasing block on the boom delivers grease to hard-to-reach locations on the front.

**Fan Guard.** Engine radiator fan is completely enclosed by fine wire mesh, reducing the risk of an accident.

**Anti-Skid Plate.** Anti-skid plate covers top of storage box and upper structure to prevent slipping during maintenance.

**Diagnostics and Monitoring.** The 320D is equipped with S•O•S<sup>SM</sup> sampling ports and hydraulic test ports for the hydraulic system, engine oil, and for coolant. A test connection for the Cat Electronic Technician (Cat ET) service tool is located behind the cab.

**Extended Service Interval.** 320D service and maintenance intervals have been extended to reduce machine service time and increase machine availability.

## Complete Customer Support

*Cat dealer services help you operate longer with lower costs.*



**Product Support.** You will find nearly all parts at our dealer parts counter. Cat dealers utilize a worldwide computer network to find in-stock parts to minimize machine down time. Save money with remanufactured components.

**Machine Selection.** Make detailed comparisons of the machines you are considering before you buy. What are the job requirements, machine attachments and operating hours? What production is needed? Your Cat dealer can provide recommendations.

**Purchase.** Look past initial price. Consider the financing options available as well as day-to-day operating costs. This is also the time to look at dealer services that can be included in the cost of the machine to yield lower equipment owning and operating costs over the long run.

**Customer Support Agreements.** Cat dealers offer a variety of product support agreements, and work with customers to develop a plan the best meets specific needs. These plans can cover the entire machine, including attachments, to help protect the customer's investment.

**Operation.** Improving operating techniques can boost your profits. Your Cat dealer has videotapes, literature and other ideas to help you increase productivity, and Caterpillar offers certified operator training classes to help maximize the return on your investment.

**Maintenance Services.** Repair option programs guarantee the cost of repairs up front. Diagnostic programs such as Scheduled Oil Sampling, Coolant Sampling and Technical Analysis help you avoid unscheduled repairs.

**Replacement.** Repair, rebuild, or replace? Your Cat dealer can help you evaluate the cost involved so you can make the right choice.

## Cat® 320D Total Solutions

*Your excavator is more than a piece of equipment; it's your livelihood.*



**More Than a Machine.** The Caterpillar 320D excavator provides all the elements to give you the lowest cost to own and operate. At the end of the day, it all comes down to how much work you got done and how much did it cost you. Caterpillar and the 320D offer you the tools to help lower your owning and operating costs:

- Better Fuel Efficiency – In addition, Economy mode use can result in up to 15% less fuel consumption compared to the C Series.
- More Performance – Finish the job faster. Increased hydraulic system pressure creates 5% greater stick and bucket forces and increased drawbar pull.
- Proven Reliability and Durability – Maximizes your up-time and provides long life and value. The 320D has endured thousands of hours of operation, through comprehensive field follow program, in a variety of applications throughout the world.
- Ease of Operation – Takes the complication out of operating. The monitor gives you vital operating and performance information, alerts in text, all in a simple, easy to navigate format in one of 27 languages, including Bahasa.
- More Versatility – Takes the complication out of operating. The monitor gives you vital operating and performance information, alerts in text, all in a simple, easy to navigate format in one of 27 languages, including Bahasa.
- Better Serviceability – Making it easier to perform service and routine maintenance. The 320D sets itself apart with the level of ground level access and maintenance features.
- Extended Maintenance Intervals – Less out of pocket expenses over the life of the machine. The 320D provides industry leading maintenance intervals that provide less cost over the life of the machine.
- More Solutions – Caterpillar and its dealer network have the ability to match a solution best suited to your needs. Your Cat dealer helps you operate longer with lower costs, by assisting you with a plan that can cover everything from machine configuration to eventual replacement.

## Engine

Engine Model	Cat® C6.4 ACERT™	
Net Flywheel Power	103 kW	138 hp
Net Power – ISO 9249	103 kW	138 hp
Bore	102 mm	4.02 in
Stroke	130 mm	5.12 in
Displacement	6.37 L	389 in <sup>3</sup>

- The Cat C6.4 meets exhaust emissions equivalent to former USA EPA Tier 2 and EU Stage II engine emissions regulations.
- Net power advertised is the power available at the flywheel when the engine is equipped with fan, air cleaner, muffler and alternator.
- No engine derating needed up to 2300 m (7,500 ft).

## Weights

Operating Weight – Std. Undercarriage	21 450 kg	47,290 lb
Counterweight	3860 kg	8,510 lb

- Heavy Duty Reach boom, R2.9B1 (9 ft 6 in) Reinforced Stick, 0.9 m<sup>3</sup> (1.2 yd<sup>3</sup>) General Purpose Bucket, 800 mm (32 in) Shoes

## Service Refill Capacities

Fuel Tank Capacity	410 L	108 gal
Cooling System	25 L	6.6 gal
Engine Oil	30 L	8 gal
Swing Drive	8 L	2.1 gal
Final Drive (each)	10 L	2.6 gal
Hydraulic System (including tank)	260 L	69 gal
Hydraulic Tank	120 L	32 gal

## Swing Mechanism

Swing Speed	11.5 rpm	
Swing Torque	62 kN·m	45,600 lb ft

## Drive

Maximum Drawbar Pull	206 kN	46,310 lb
Maximum Travel Speed	5.5 km/h	3.4 mph

## Hydraulic System

Main Implement System – Maximum Flow (2x)	205 L/min	54 gal/min
Maximum pressure – Equipment	35 000 kPa	5,076 psi
Maximum pressure – Travel	35 000 kPa	5,076 psi
Maximum pressure – Swing	25 000 kPa	3,626 psi
Pilot System – Maximum flow	32.4 L/min	8.6 gal/min
Pilot System – Maximum pressure	3900 kPa	566 psi
Boom Cylinder – Bore	120 mm	4.7 in
Boom Cylinder – Stroke	1260 mm	49.6 in
Stick Cylinder – Bore	140 mm	5.5 in
Stick Cylinder – Stroke	1504 mm	59.2 in
B1 Family Bucket Cylinder – Bore	120 mm	4.7 in
B1 Family Bucket Cylinder – Stroke	1104 mm	43.5 in

## Sound Performance

Performance	ANSI/SAE J1166 OCT 98
-------------	-----------------------

- When properly installed and maintained, the cab offered by Caterpillar, when tested with doors and windows closed according to ANSI/SAE J1166 OCT 98, meets OSHA and MSHA requirements for operator sound exposure limits in effect at time of manufacture.
- Hearing protection may be needed when operating with an open operator station and cab (when not properly maintained or doors/windows open) for extended periods or in noisy environment.

## Standards

Brakes	SAE J1026 APR90
Cab/FOGS	SAE J1356 FEB88

## Track

Standard w/Standard Undercarriage	800 mm	32 in
-----------------------------------	--------	-------

## Dimensions

Transport width	3000 mm	118.11 in
-----------------	---------	-----------

## Dimensions

All dimensions are approximate.

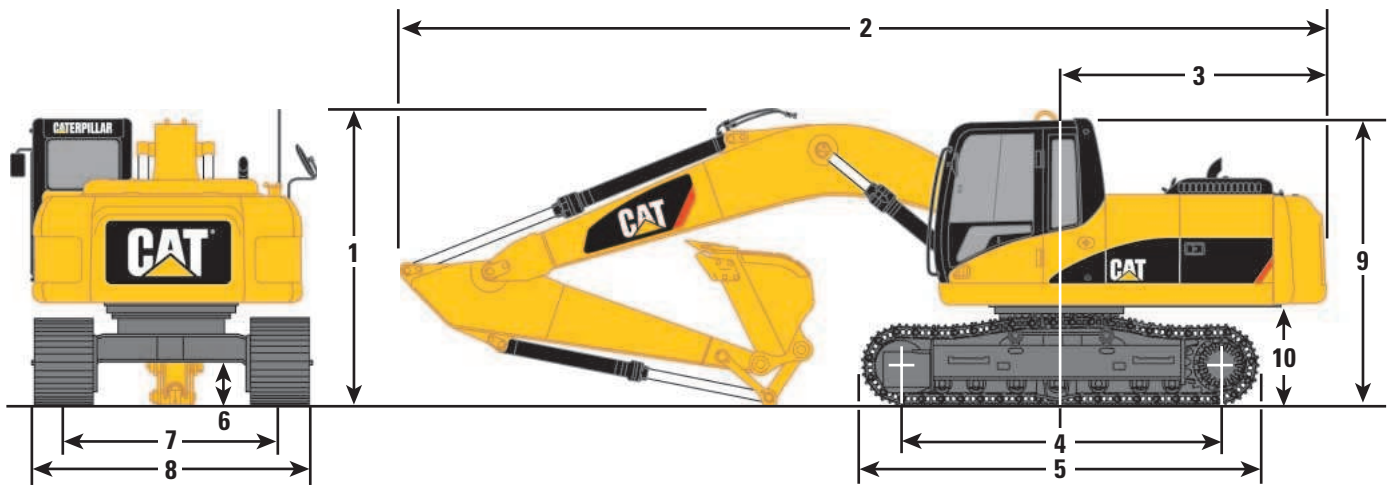

### Boom Options

Reach  
5.68 (18'7")

### Stick Options

R2.9B1 m (9'7")  
Std/SA

<b>1</b> Shipping Height	3030 mm (9'11")
<b>2</b> Shipping Length	9460 mm (31'0")
<b>3</b> Tail Swing Radius	2750 mm (9'0")
<b>4</b> Length to Center of Rollers	3265 mm (10'9")
<b>5</b> Track Length	4075 mm (13'4")
<b>6</b> Ground Clearance	450 mm (1'6")
<b>7</b> Track Gauge	2200 mm (7'3")
<b>8</b> Transport Width	800 mm Shoes 3000 mm (9'10")
<b>9</b> Cab Height	2950 mm (9'8")
<b>10</b> Counterweight Clearance	1020 mm (3'4")

# Reach Excavator Working Ranges

Reach (R) boom configuration

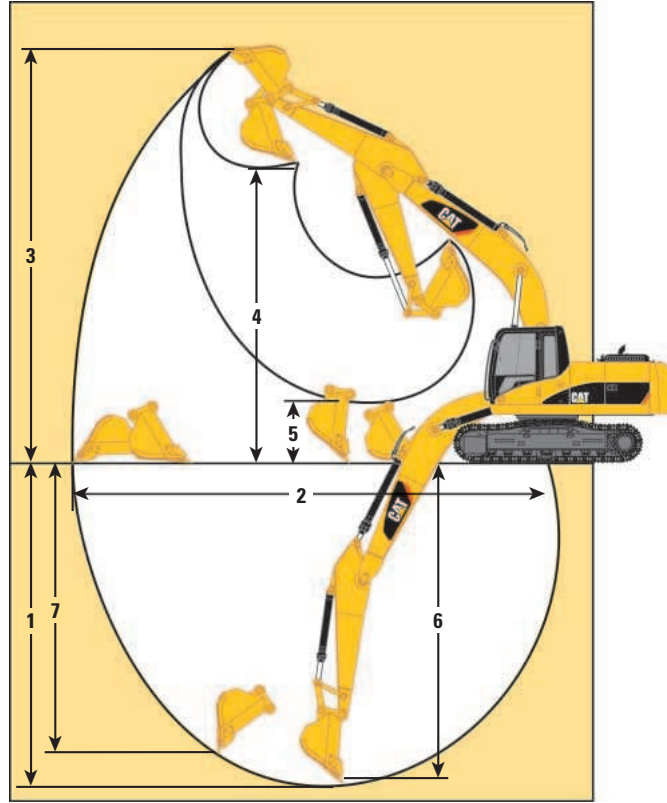

## Boom Options

## Reach

**5.68 m (18'7")**

## Stick Options

**R2.9B1 m (9'7")**

<b>1</b> Maximum Digging Depth	6580 mm (21'7")
<b>2</b> Maximum Reach at Ground Level	9710 mm (31'10")
<b>3</b> Maximum Cutting Height	9360 mm (30'9")
<b>4</b> Maximum Loading Height	6640 mm (21'9")
<b>5</b> Minimum Loading Height	2310 mm (7'7")
<b>6</b> Maximum Depth Cut for 2440 m (8') Level Bottom	6400 mm (21'0")
<b>7</b> Maximum Vertical Wall Digging Depth	5800 mm (19'0")
Bucket Digging Force (SAE)	137.5 kN (30,910 lb)
(ISO)	155.6 kN (34,980 lb)
Stick Digging Force (SAE)	105.6 kN (23,740 lb)
(ISO)	109.9 kN (24,710 lb)

All measurements are approximate

## Major Component Weights

	kg	lb
Base machine with counterweight and 800 mm (32") shoes (without front linkage)	17 210 kg	37,950 lb
Upper Structure without counterweight	6090 kg	13,430 lb
Undercarriage with 800 mm (32") triple grouser shoes	7260 kg	16,010 lb
Counterweight	3860 kg	8,510 lb
<b>Boom</b>		
Two Boom Cylinders (each)	175 kg	380 lb
Boom 5.7 m (19') Heavy Duty Reach (includes lines, pins, and stick cylinder)	2020 kg	4,460 lb
Stick Cylinder	280 kg	620 lb
<b>Stick</b>		
Stick R2.9B1 Reinforced (includes lines, pins, bucket cylinder and linkage)	1090 kg	2,400 lb
Stick R2.9B1 Heavy Duty (includes lines, pins, bucket cylinder and linkage)	1120 kg	2,470 lb
Bucket Cylinder	160 kg	350 lb
Bucket Linkage	140 kg	310 lb

## 320D Bucket Specifications

	Capacity		Width		Tip Radius		Weight (with tips)		Teeth Qty	Heavy Duty Reach Boom Stick	
	m <sup>3</sup>	yd <sup>3</sup>	mm	in	mm	in	kg	lb		R2.9 reinforced	R2.9 HD
<b>B1 Buckets</b>											
General Purpose	0.9	1.2	1210	47.6	1426	56.1	738	1,627	6	●	●
Heavy Duty	1.0	1.3	1067	42.0	1578	62.1	912	2,011	5	—	●
Heavy Duty Power	1.0	1.3	1067	42.0	1404	55.3	923	2,035	5	—	●
Heavy Duty Rock	1.0	1.3	1067	42.0	1578	62.1	994	2,191	5	—	●

Assumptions for maximum material density rating:

1. Front linkage fully extended at ground line
2. Bucket curled
3. 100% bucket fill factor

- 1800 kg/m<sup>3</sup> (3,000 lb/yd<sup>3</sup>) max material density
- 1500 kg/m<sup>3</sup> (2,500 lb/yd<sup>3</sup>) max material density
- Not Available

## 320D Work Tool Matching Guide

Boom Options	Reach Boom 5.7 m (18'7")
Stick Options	R2.9B1 (9'7")
Hydraulic Hammer	H115s/H120Cs/H130s
Vibratory Plate Compactor	CVP110
Trash Grapple	2.7 m <sup>3</sup> /3.5 yd <sup>3</sup>
Contractors' Grapple	yes
Hydraulic Thumb	yes
Dedicated Quick Coupler	yes
Pin-Grabber Quick Coupler	yes



# Reach Boom Lift Capacities



Load Point Height



Load Radius Over Front



Load Radius Over Side

















Load at Maximum Reach

**FRONT:** Heavy Duty Reach Boom, R2.9B1 Reinforced Stick

**BUCKET:** 0.9 m<sup>3</sup> (1.2 yd<sup>3</sup>) General Purpose

**TRACK SHOE:** 800 mm (32") triple grouser shoe

		1.5 m (5.0 ft)		3.0 m (10.0 ft)		4.5 m (15.0 ft)		6.0 m (20.0 ft)		7.5 m (25.0 ft)				m ft
														
7.5 m	kg											*2050	*2050	7.75
25.0 ft	lb											*4,550	*4,550	25.11
6.0 m	kg									*3250	2750	*1950	*1950	8.73
20.0 ft	lb											*4,300	*4,300	28.47
4.5 m	kg							*4450	4150	*4150	2750	*1950	1800	9.30
15.0 ft	lb							*9,700	8,900	*9,100	5,800	*4,250	3,950	30.44
3.0 m	kg			*10 700	*10 700	*6750	6250	*5300	3900	4150	2600	*2000	1600	9.55
10.0 ft	lb			*22,750	*22,750	*14,550	13,450	*11,400	8,350	8,900	5,550	*4,400	3,550	31.33
1.5 m	kg					*8500	5600	5800	3600	4000	2450	*2200	1550	9.53
5.0 ft	lb					*18,250	12,100	12,400	7,700	8,550	5,250	*4,750	3,450	31.26
Ground Line	kg			*6250	*6250	8800	5200	5550	3400	3900	2350	*2450	1650	9.22
	lb			*14,350	*14,350	18,850	11,200	11,850	7,250	8,300	5,000	*5,350	3,600	30.24
-1.5 m	kg	*5750	*5750	*9750	*9750	8600	5050	5400	3250	3800	2300	*2900	1850	8.59
-5.0 ft	lb	*12,850	*12,850	*22,100	21,150	18,450	10,900	11,600	7,000	8,200	4,900	*6,350	4,100	28.15
-3.0 m	kg	*9700	*9700	*13 800	10 100	8650	5100	5400	3250			*3700	2400	7.56
-10.0 ft	lb	*21,800	*21,800	*29,800	21,600	18,550	10,950	11,600	7,000			*8,200	5,300	24.68
-4.5 m	kg			*11 350	10 500	*7900	5300					*4050	3700	5.93
-15.0 ft	lb			*24,350	22,500	*16,900	11,400					*8,900	8,300	19.26

\* Limited by hydraulic capacity rather than tipping load. The above loads are in compliance with SAE hydraulic excavator lift capacity rating standard J1097. They do not exceed 87% of hydraulic lifting capacity or 75% of tipping capacity. Weight of all lifting accessories must be deducted from the above lifting capacities.

## Standard Equipment

*Standard equipment may vary. Consult your Caterpillar dealer for details.*

### Upper Structure

#### Electrical

- Alternator, 50A
- Light, storage box mounted (one)
- Signaling/Warning horn

#### Engine

- C6.4 with ACERT™ Technology
  - 2300 m (7,500 ft) altitude capability with no deration
  - 2 micron fuel filter
  - Equivalent EU Stage 2 / EPA Tier 2 Emission compliant
  - Air intake heater
  - Automatic engine speed control with one touch low idle
  - High ambient cooling package
  - Radial seal air filter
  - Water separator in fuel line with 10 micron fuel filter with water level indicator
  - Waved fin radiator with space for cleaning
  - Auxiliary hydraulic valve (one)
  - Automatic swing parking brake
  - Boom drift reducing valve
  - Boom lowering device for back-up
  - Capability of stackable valves for main valve (maximum three valves)
  - Capability of auxiliary circuit (aux. pump and valves)
  - Capability of boom and stick lowering control device
  - Cat data link with capability of E.T.
  - Caterpillar one key security system
  - Counterweight
  - Door locks and cap locks
  - Mirrors, rearview (frame-right, cab-left)
  - Regeneration circuit for boom and stick
  - Reverse swing damping valve
  - Secondary engine shutoff switch
  - Steel wall between engine and pump compartment
  - Stick drift reducing valve
  - Straight travel hydraulic circuit
  - Two speed auto shift travel
- ### Undercarriage
- 800 mm (36 in) triple grouser track shoe
  - Grease lubricated GLT2, resin seal
  - Idler and center section track guiding
  - Towing eye on baseframe
- ### Front Linkage
- Bucket linkage, B1-family with lifting eye
  - Heavy Duty 5.7 m reach boom (with left side light)
  - Reinforced R2.9B1 stick for heavy-duty reach boom (MA1) or Heavy-duty R2.9B1 stick for heavy-duty reach boom (MA2)

### Operator Station

#### Cab

- 12V-7A power supply w/ cigar lighter type socket
- Adjustable armrest
- Antenna & Harness (without radio speakers)
- Ashtray with lighter
- Beverage holder
- AC bi-level air conditioner with defroster
- Bolt-on FOGS Capability
- Capability of installing two additional pedals
- Coat hook
- Front guard boss
- Front windshield glass split 70/30
- Head Rest
- Interior lighting
- Joystick , Control lever joysticks
- Laminated front windshield and tempered other windows
- Literature holder
- Lunch box with cover
- Mounting for two stereo speakers (two locations)
- Neutral lever (lock out) for all controls
- Openable front windshield with assist device
- Openable skylight polycarbonate with sunshade
- Pillar mounted upper windshield wiper and washer
- Positive filtered ventilation
- Radio mounting (DIN size)
- Rear window, emergency exit
- Removable lower windshield with in-cab storage bracket
- Seat suspension, four way adjustable low back with integrated, adjustable console
- Seat belt, retractable (two inch width)
- Sliding upper door window
- Start Switch Panel
- Sun visor
- Travel control pedals with removable hand levers
- Utility space for magazine
- Washable floor mat
- Working lights, cab mounted

#### Monitor

- Economy mode
- Full time clock
- Language display – Full color and graphical display
- Machine condition, error code and tool mode setting
- Start-up level check for hydraulic oil, engine oil and coolant
- Warning information, filter/fluid change information and working hour

## Optional Equipment

*Optional equipment may vary. Consult your Caterpillar dealer for details.*

Bucket 0.9 m<sup>3</sup> General Purpose

(use with Heavy-duty or Reinforced 2.9B1 sticks)

Bucket 1.0m<sup>3</sup> Heavy Duty (use with Heavy-duty 2.9B1 stick)

Bucket 1.0m<sup>3</sup> Heavy Duty Power

(use with Heavy-duty 2.9B1 stick)

Bucket 1.0m<sup>3</sup> Heavy Duty Rock

(use with Heavy-duty 2.9B1 stick)

Forestry fixed grapple (requires Reinforced 2.9B1 stick only)

Tips, Side cutters and Side protectors

# 320D Hydraulic Excavator

For more complete information on Cat products, dealer services,  
and industry solutions, visit us on the web at [www.cat.com](http://www.cat.com)

© 2007 Caterpillar  
All Rights Reserved  
Printed in U.S.A.

Materials and specifications are subject to change without notice.  
Featured machines in photos may include additional equipment.  
See your Caterpillar dealer for available options.

AEHQ5892 (5-07)

PTNR

CAT, CATERPILLAR, their respective logos, ACERT, "Caterpillar Yellow" and the  
POWER EDGE trade dress, as well as corporate and product identity used herein,  
are trademarks of Caterpillar and may not be used without permission.

**CATERPILLAR<sup>®</sup>**