

FLEXIBLE AND EFFICIENT DEMOLITION

325D, 330D, 345C, 365C, 385C ULTRA-HIGH DEMOLITION (UHD)

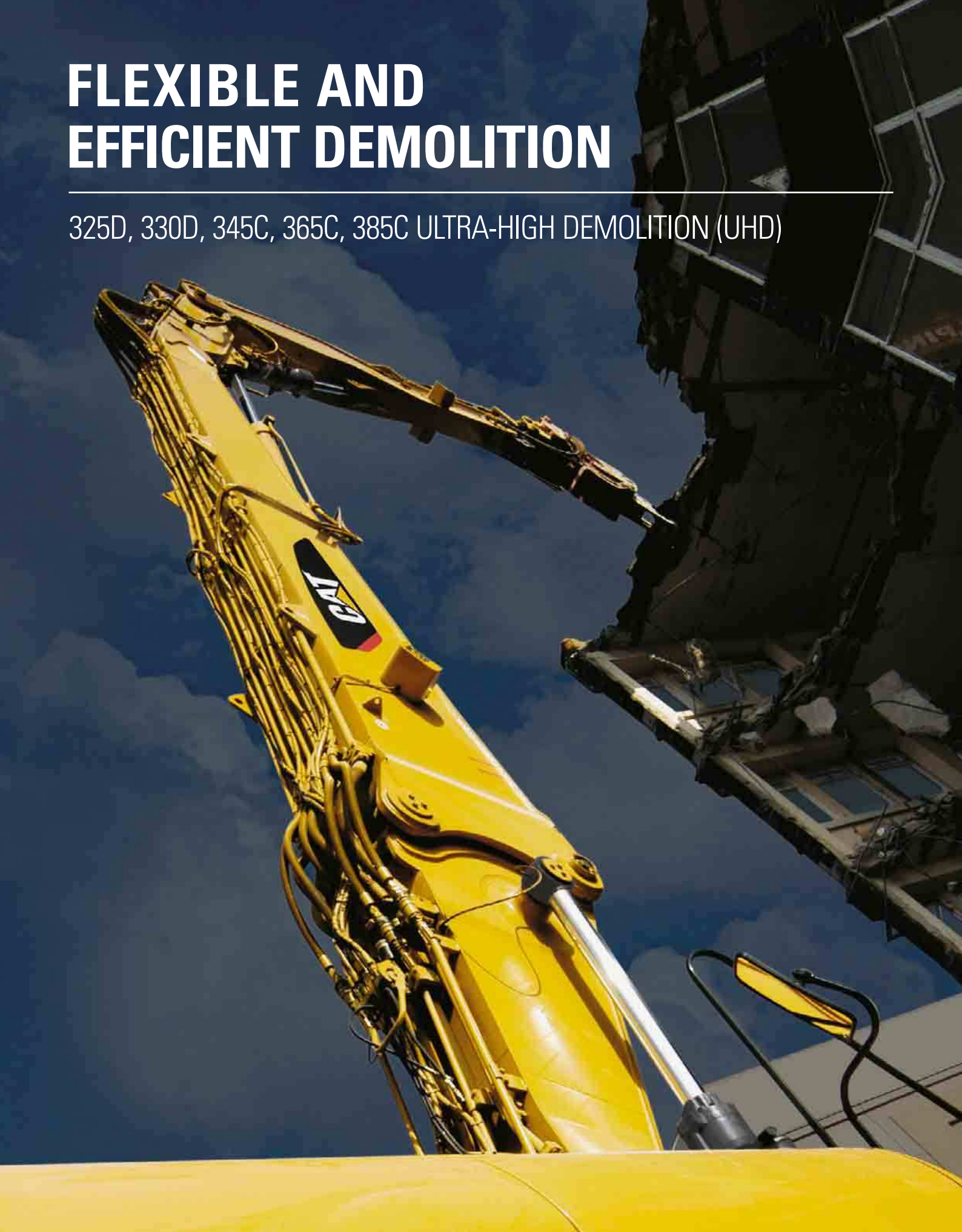

CATERPILLAR[®]

Courtesy of Machine.Market

A Dynamic and Complex Business



Demolition has changed. It has become a dynamic and increasingly complex business. Today there are few demolition jobs where buildings can simply be knocked, pulled or blown down using traditional tools. What's more, contract periods are becoming shorter, legislation is stricter, environmental pressure is increasing and skilled labour is harder to find. As a consequence, demolition contractors are looking for the most efficient, cost effective and safe methods of deconstructing buildings and structures.



Increasing Productivity throughout the Process

Caterpillar engineers have designed and produced specialized machines with the objective of increasing productivity at every stage of the process. Added to that, our machines have been developed with an emphasis on stability, durability and ease of use. They also come with the back-up of your local Cat dealer. They can help you with finding the right machine and tools for the job and advise you how to get the most out of your equipment.

Ultra High Demolition

	Weight* (metric tons)	Max pin height mm	Max horizontal pin reach mm	Max tool weight (over the front)** kg	Max tool weight (360°)** kg
325D UHD (18 m)	37.5	17 500	10 700	3 000	3 000
330D UHD (21 m)	47.9	21 300	13 900	3 000	2 700
345C UHD (26 m)	66.7	26 100	16 400	3 300	3 000
345C UHD (28 m)	67.0	27 900	18 200	2 500	2 500
365C UHD (33 m)	85.7	33 100	21 500	3 000	2 000
385C UHD (40 m)	98.7	39 500	25 200	2 400	2 100

* Maximum weight in UHD configuration with heaviest undercarriage. Figures are approximate and do not include the tool.

** Includes potential quick coupler and mounting bracket. The max. tool weight depends on the U/C configuration.



Visual Overview – Index

Hydraulic Quick Disconnects and face-to-face ball valves p. 10

Hydraulic lines are fitted with quick disconnects or face-to-face ball valves to reduce the time needed to change the front parts.

Boom Hook System p. 10

A reliable boom hook system enables to switch from Ultra High Demolition (UHD) front parts to standard or Long Reach Excavation (LRE) configurations*. These retrofit booms can be installed either in bent or in straight position.

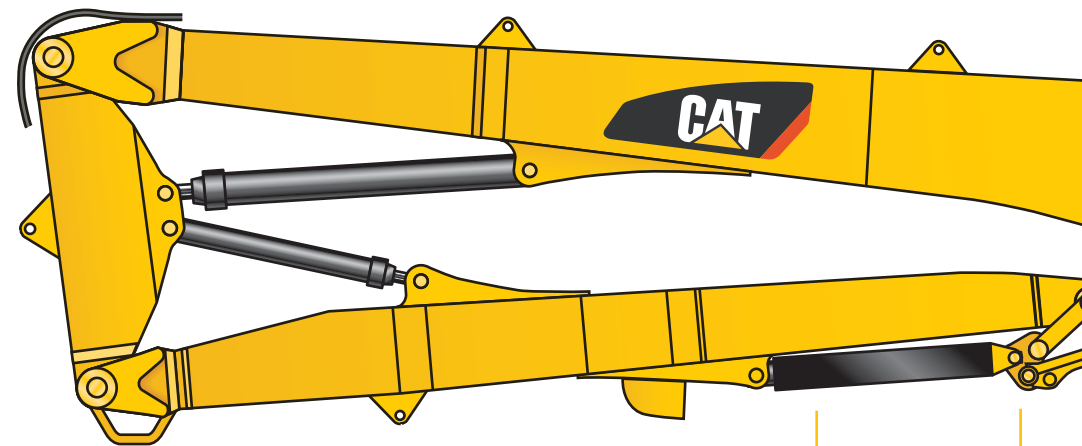

Tool Cylinder protection p. 7

Thanks to this metal box, the tool cylinder is protected in all working positions.

Ultra-High Demolition Linkage p. 9

Optimized working range and improved tool controllability, thanks to an UHD-dedicated tool linkage.

* Long Reach Excavation (LRE) Retrofit front parts are available on demand.

Integrated Tilttable

Demolition Cab

p. 8

Hydraulic cab tilting device for operator comfort. Enhanced upper visibility through larger impact-resistant windows with Falling Object Guard System (FOGS).

Heavy Duty Upper Frame

p. 6

Reinforced structures to withstand the extreme conditions of the demolition applications.

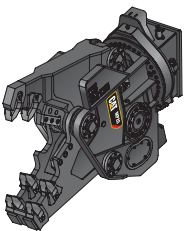
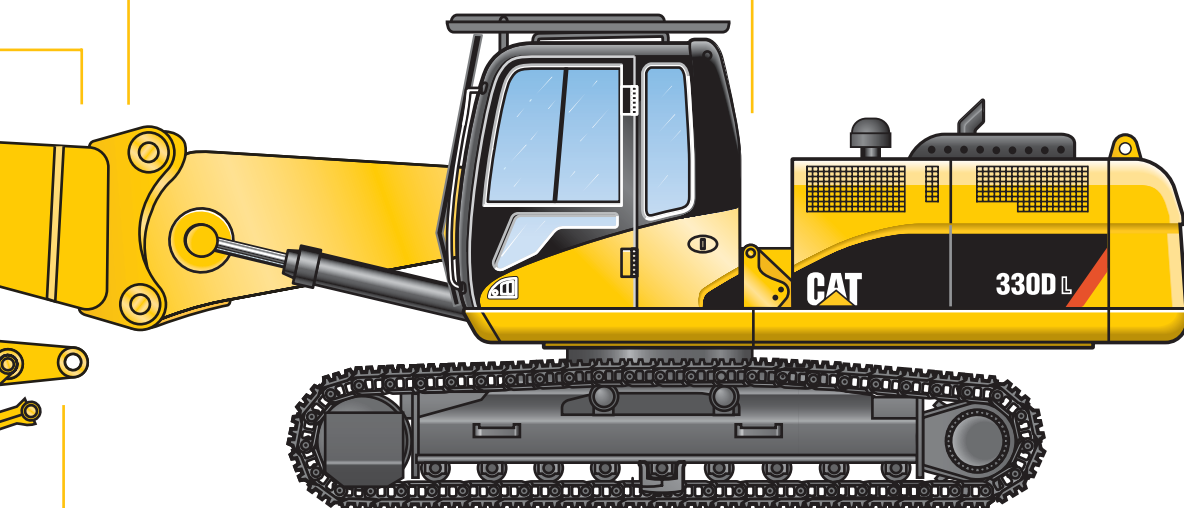

Tools

p. 12

Several tool options maximize versatility.

Undercarriage

p. 11

Several undercarriage options.

Reliability

Several major features make the Caterpillar Ultra High Demolition (UHD) models the most reliable machines in demolition applications.

Upper Frame and Counterweight

Purposely designed and built for extreme conditions.

Reinforced upper frame

The heavy-duty reinforced upper frames of the CAT UHD models are designed to withstand the extreme load conditions of demolition applications. Compared to a standard upper frame, several additional plates provide the durability and strength required in these environments.



Reinforced upper frame

Swing bearing to upper frame bolts

The swing bearing bolts are 20 mm longer on the back half of upper frame for increased joint retention. Bolt grade is increased from 10.9 to 11.9 for increased bolt torque of swing bearing to upper frame and carbody.



Standard



Heavy-duty

Swing bearing bolts

Counterweight

A heavier counterweight balances the swing bearing and provides enhanced stability.

Front Parts

All Caterpillar booms and sticks have internal baffles which give the structures extra strength and durability. They are designed based on a precise finite element analysis that highlights all the potential stress areas under all possible load cases. These specific areas are then reinforced accordingly.

Caterpillar excavator booms and sticks are built for performance and long service life.

- Castings and forgings are used at high stress areas such as boom nose, boom foot, boom cylinder and stick foot.
- Large, welded, box-section structures with thick, multi-plate fabrications in high-stress areas to better withstand torsional loads.
- All booms and sticks go through a stress relief heat treatment to maximize fatigue life and durability.

Tool Cylinder Protection

To prevent damage to the tool cylinder rod caused by falling concrete and debris, the tool cylinder is equipped with a heavy duty metal cover. Thanks to its unique construction, the cover protects the cylinder rod in every position.



Tool cylinder protection

Demolition Sticks

The Demolition sticks are made of thick plates (on top, bottom and side) and have additional internal baffles to improve their resistance to torsion stresses. They also feature hardened bores at all connections (connections with boom and tool linkage). Additional wear plates on the bottom side and around the nose extend the whole stick life.

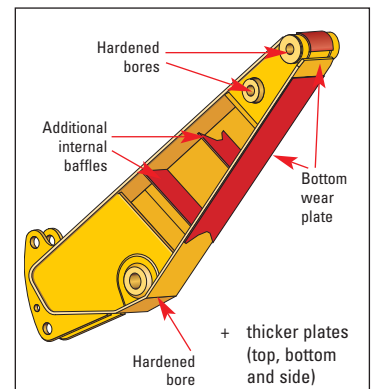

Demolition sticks

Operator Comfort and Safety

Operator comfort and safety is critical in demolition applications.

Hydraulically tiltable cab

The hydraulically tiltable cab tilts back to further improve upward visibility and to allow the operator to adopt a more comfortable body position. The tiltable cab is integrated into the upper frame and therefore does not increase the machine's shipping height. Moreover, because of the integration into the upper frame, no tilt parts are exposed to the demolition environment. To reduce vibrations and sound, the cab shell is attached to the frame with viscous mounts.



Automatic climate control

Fully automatic climate control adjusts temperature and flow and determines which air outlet is best in each situation.

High visibility demolition cab

The thick laminated safety glass front window is one-piece with a bottom mounted parallel wiper for excellent visibility. For enhanced upward visibility, the impact resistant top window extends completely to the rear and has a wiper and washer.



Falling object guard

The ISO 10262-1998 certified falling object guard on top and front of the cab is standard. The crossbars of the top guard are angled in line with the operator's sight for enhanced visibility of the work tool. The front guard swings out for easier windshield cleaning.

Productivity

Cat Ultra High Demolition (UHD) machines are designed for maximum productivity in all demolition applications.

Working Height

While the maximum pin height is given as a reference to compare machines, the actual "working height" is always different. An experienced operator will never work above a safety line that extends from the front edge of the tracks and follows a "1:2" rule (2 meters of vertical height for 1 meter of horizontal reach). Working under this line is generally accepted as a safety rule to avoid any risk of debris falling on the machine. Caterpillar UHD excavators have been purposely designed with the "1:2" line in mind and show therefore the best working heights and enhanced performances along that line.

Dedicated UHD tool linkage

Because UHD applications require different working positions than standard applications, CAT engineers developed a purpose-designed linkage for the UHD front parts. Besides providing an optimized working envelope, this linkage also greatly improves the tool controllability.

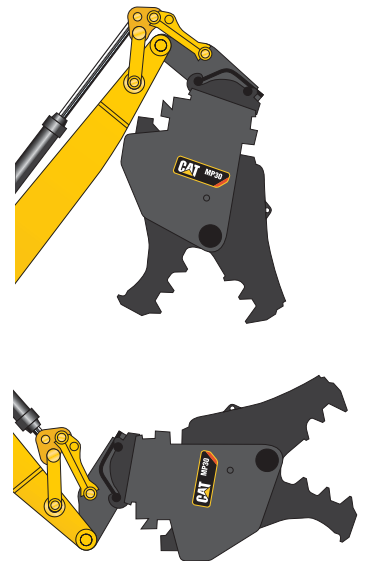
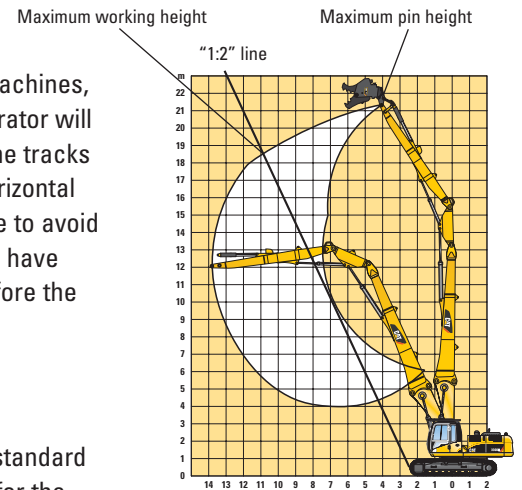

Versatility

The extreme versatility of the Cat Ultra High Demolition (UHD) models enable these machines to work in a wide range of applications, like truck loading and long reach digging.

Retrofit (short 2P, LRE 2P on 330D UHD)

Versatility – retrofit

A short boom nose can be hooked onto the bottom foot. To maximize the machine's extreme versatility, this boom nose can be put in two different positions. The straight position is ideal for working in above ground level applications, such as low level demolition or sorting. The bent position can be used for applications such as digging or truck loading.

For long reach digging and extracting applications, two-piece long reach excavation attachments can be adapted to the base demolition machine of the 330D UHD model. These LRE front parts also have the two mounting positions. Optional medium pressure lines also enable the use of tilting buckets.

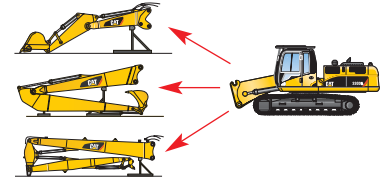

High versatility

Boom Hook System with Quick Disconnects

Boom hook system

The front parts are equipped with a reliable and safe hook system between the boom foot and boom nose. Compared to the traditional pin-mounted joint, the hook system significantly reduces the time needed to change between the Ultra-high front parts and the retrofit configurations. In principle, the boom hook system consists of a hook to pick up the front parts and a mechanical expander pin to secure them onto the boom foot. The absence of any hydraulic parts, as well as a full length heavy duty one-piece securing pin, ensure safe and reliable operation. The operator has an excellent view of the hook system from the cab to easily change the front parts.



Hydraulic quick disconnects

Hydraulic quick disconnects and face-to-face ball valves

On 325D and 330D, the hydraulic lines between boom foot and boom nose are fitted with hydraulic quick disconnects to even further reduce the time needed to change the front parts. Oil spillage and contamination is reduced through the quick disconnects flat-face design. On larger models, face-to-face ball valves assure the unmatched reliability required for high hydraulic flows.

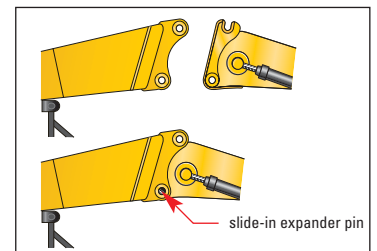

Boom hook system

Tool Control System

Tool control

Ten hydraulic pump flow and pressure settings can be preset on the monitor (Electronic Control System), eliminating the need to adjust the hydraulics each time a tool is changed. Selecting the proper setting from the monitor's menu instantly provides the operator with the correct amount of flow and pressure for the tool. The unique Cat proportional sliding switches provide modulation to the tool and make precision work easy.



Tool control

Undercarriage

Several undercarriage options are available to choose the best machine for the application and business needs. A variety of standard and heavy-duty track shoes are available for various underfoot conditions.

Long Undercarriage (L)

The long undercarriage provides a stable and rugged working platform for demolition.

Long Narrow Undercarriage (LN)

The long narrow undercarriage reduces shipping width while maintaining excellent performance.

Hydraulic Variable Gauge Undercarriage (HVG)

The hydraulic variable gauge undercarriage increases the stability through increased track gauge in working position, as well as by lowering the center of gravity of the machine. The non-bolt joint allows a change from shipping to working width, or reverse, in less than one minute.

Heavy Duty High Wide Undercarriage (HDHW)

Compared to the long undercarriage, the heavy-duty high wide undercarriage (HDHW) provides increased over-the-side stability as well as increased ground clearance. Thicker carbody plates, plus larger box-section height team up to provide superior joint retention and durability in demolition applications.

Extreme Service Undercarriage (ES)

The 330D and 345C UHD models can also be equipped with an upsized undercarriage called "Extreme Service" undercarriage. Mounted on a 330D, the 345C L variable gauge heavy-duty, H-shaped long undercarriage provides ease of transport and a stable platform when working on a variety of sites. Another benefit of the 345C L undercarriage is the increased ground clearance. With 600 mm track shoes, the track roller frames can be retracted to a transport width of less than three meters. The ES undercarriage is standard on the 365C UHD (365C base machine with 385C L undercarriage).



330D HVG



325D HDHW

Undercarriage Options for UHD

	325D L	325D LN	325D HDHW	330D L	330D LN	330D HDHW	330D HVG	345C L	345C HVG	365C L	385C L
325D UHD	✓	✓	✓								
330D UHD				✓	✓	✓	✓	✓			
345C UHD								✓	✓	✓	
365C UHD											✓
385C UHD											✓

Work Tools

The right work tools are critical when it comes to getting the best productivity and flexibility from a machine.

Connect'o'maat™ dedicated Quick Couplers

The Connect'o'maat dedicated quick coupler is available in reinforced version with a special shape for UHD applications. It can pick up any work tool, equipped with optimized hinges for maximum breakout force and has wide interchangeability over different machine size classes.

- Cast body for high strength
- Solid and wear resistant construction
- Hydraulic versions (all size excavators)
- Spindle versions (up to and including model 345C)
- Easy to operate
- Minimal loss of breakout force.

Only CW40 or CW40s, CW45 or CW45s ("s" is for the narrow version of the QC) for UHD. Two different wedge systems available: Mechanical with spindle (D) and Hydraulic (H) requires actuation and control unit.

Sorting and Demolition Grapples

Caterpillar Sorting and Demolition Grapples feature 360 degree hydraulic rotation. They are equally well suited for demolition of brick and wood structures. These grapples are extremely effective to dismantle the exterior of the building. Wood, stone and steel are separated from each other at the source.

Features:

360° Hydraulic Rotation

Grapple is equipped with a hydraulic rotator, capable of spinning the grapple a full 360° in four seconds. The operator can precisely position the grapple at any angle to easily grasp irregularly-shaped loads, or precisely pick and sort material from a pile.

Replaceable Wear Plates

Cutting edges feature bolt-on, reversible wear plates of Hardox 500 steel. These long-wearing plates can be rotated 180 degrees for double the normal amount of service life before needing to be replaced.

Built For Demolition

The rugged construction, speed (1.7 second open-close cycle time), and clamping force are designed for the high-demand demolition job site.

Bolt-on Mounting Brackets

The grapple is equipped with a bolt-on mounting bracket, allowing for the unit to be easily adapted to work with multiple machine linkages.



Mechanical with spindle CW-05 up to CW-55(s)



Hydraulic requires actuation and control unit CW-05 up to CW-100



Work Tools

Multi-Processors for Excavators

We have hydraulic continuous-rotating demolition tools with interchangeable jaws for crushing, cutting and pulverizing concrete, metal structures and bulk material. The multi-processor can fit various HEX front parts configuration including retrofit boom, straight boom, UHD (Dedicated linkage).

Features:

Speed

The single large diameter, cross-mounted cylinder with speed valve provides exceptional cutting and crushing force.

360° rotation

The Multi-Processor features hydraulic 360° rotation; the unit can attack material to be demolished from virtually any angle, minimizing the need to move the base carrier.

Flexibility

Each Multi-processor can be equipped with a wide selection of interchangeable jaws. With one common housing and properly selected sets of jaws a contractor can achieve exceptional flexibility with minimum investment.

Demolition Shears S320, S325

These shears can grab and pick material from a pile easily, without requiring movement of the base carrier. The S300 series are very efficient tools because of the high force to weight ratio. The blades are made of exceptionally long-wear alloy steel and have proven speed valves that improve cycle times from 6 to 9.5 seconds depending on shear type and excavator model. The jaw openings of the shears are matched to the high shear force. The cutting edges, mounted on the side of the shear jaws, are visible to the operator and the locking system means they can be removed safely and easily.

The robust rotation system with up to two hydraulic motors on the largest shears, provides system integrity under demanding conditions in scrap yards as well as on demolition sites. The motor torque and the structural strength of the slewing ring make it possible to handle heavy loads corresponding to the lift capacity of the excavator.

Benefits

- Large gap in lower jaw for better cutting performance
- Cutting edge configuration prevents jamming
- Easy to mount
- Simple removal of wear parts and easy maintenance of hydraulics.



Change jaws in 20-30 minutes by dedicated jaw quick change system.



Concrete Cutter Jaws



Crusher Jaws



Primary Pulverizer Jaws



Shear Jaws



Specifications – 325D (18 m)

Dimensions and Weights

Undercarriage		LONG	HD-HW	LN	
A	Shipping Length	mm	12 500	12 500	12 500
B	Boom Height	mm	2920	2920	2920
C	Cab Height (with FOGS)	mm	3205	3430	3205
D	Shipping Gauge (retracted position)	mm	–	–	–
D	Working Gauge (extended position)	mm	2590	2920	2390
E	Ground Clearance	mm	480	660	480
	Machine Weight (UHD configuration) *	kg	36 200	37 500	35 200
	Machine Weight (Retrofit Configuration) **	kg	34 330	35 690	32 960

* Without tool

** May vary depending on the stick and the bucket

Working Range

Undercarriage		LONG	HD-HW	LN	
A	Maximum allowable angle from vertical	20°	20°	20°	
B	Maximum Horizontal Reach	mm	10 730	10 730	10 730
C	Maximum Pin Height	mm	17 310	17 530	17 310
	Maximum Tool Weight (over the front)	kg	3000	3000	3000
	Maximum Tool Weight (over the side)	kg	2500	3000	2200

Engine Specs

Engine	Cat C7 with ACERT™ Technology	
Ratings	rpm	1800
Net Power (ISO 9249)	kW/hp	140/190

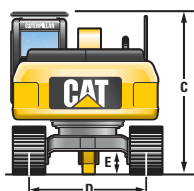
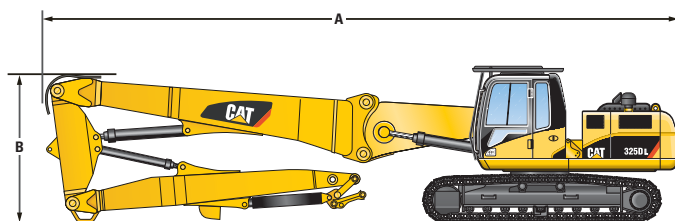

Dimensions and weights

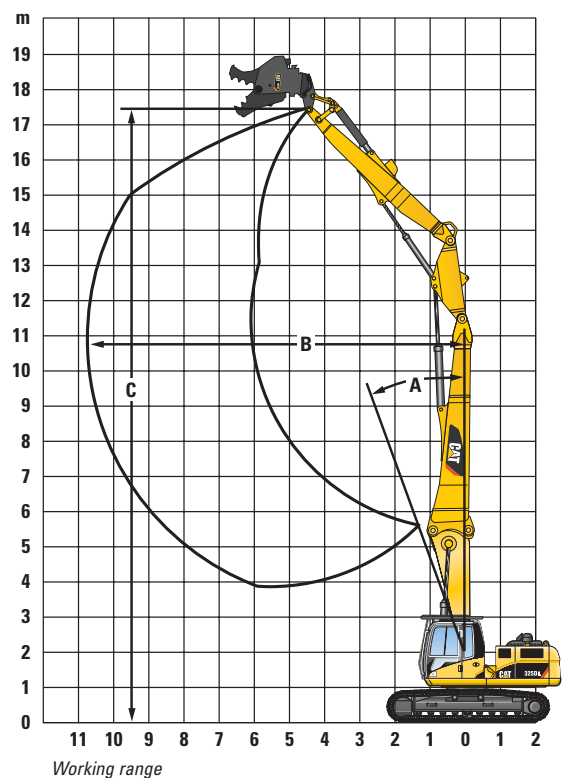

Specifications – 330D (21 m)

Dimensions and Weights

Undercarriage		LONG	HD-HW	LN	HVG	ES
A Shipping Length	mm	14 830	14 830	14 830	14 830	14 830
B Boom Height	mm	3100	3100	3100	3100	3100
C Cab Height (with FOGS)	mm	3360	3590	3360	3410	3560
D Shipping Gauge (retracted position)	mm	–	–	–	2390	2390
D Working Gauge (extended position)	mm	2590	2920	2390	2820	2890
E Ground Clearance	mm	510	720	510	480	740
Machine Weight (UHD configuration) *	kg	42 360	43 930	41 910	47 870	46 940
Machine Weight (Retrofit Configuration) **	kg	40 340	41 780	39 710	47 350	45 500
Machine Weight (LRE Retrofit configuration)	kg	–	43 020	–	46 960	46 030

* Without tool

** May vary depending on the stick and the bucket

Working Range

Undercarriage		LONG	HD-HW	LN	HVG	ES
A Maximum allowable angle from vertical		25°	25°	25°	25°	25°
B Maximum Horizontal Reach	mm	13 850	13 850	13 850	13 850	13 850
C Maximum Pin Height	mm	21 060	21 290	21 060	21 120	21 270
Maximum Tool Weight (over the front)	kg	3000	3000	3000	3000	3000
Maximum Tool Weight (over the side)	kg	1800	2450	–	2700	2700

Engine Specs

Engine	Cat C9 with ACERT™ Technology	
Ratings	rpm	1800
Net Power (ISO 9249)	kW/hp	200/270

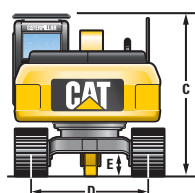
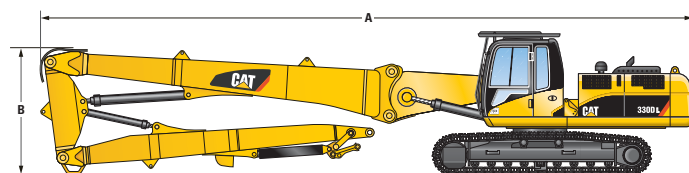

Dimensions and weights

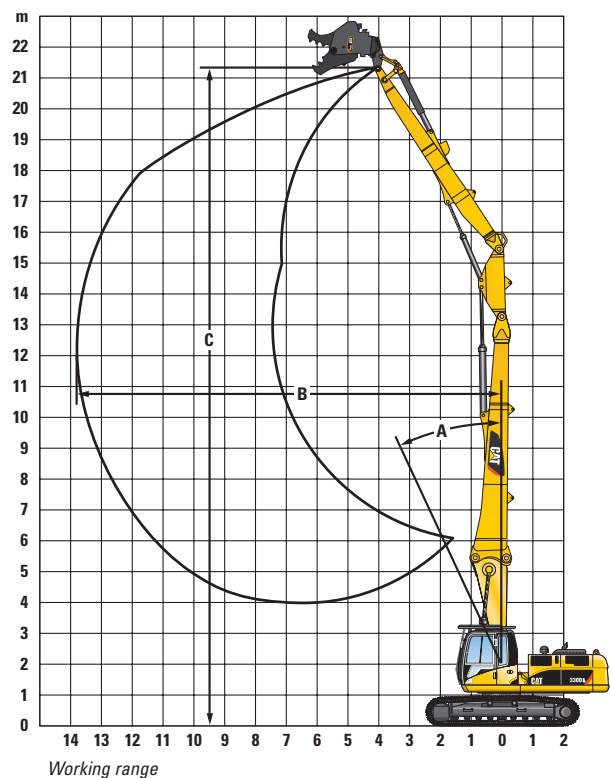

Specifications – 345C (26/28 m)

Dimensions and Weights

Undercarriage		LONG	HVG	ES	
A	Shipping Length	mm	17 800	17 800	17 800
B	Boom Height	mm	3120	3120	3120
C	Cab Height (with FOGS)	mm	3740	3720	3850
D	Shipping Gauge (retracted position)	mm	2390	2400	2250
D	Working Gauge (extended position)	mm	2890	3010	2750
E	Ground Clearance	mm	740	460	830
	Machine Weight (UHD configuration) *	kg	57 900/58 200	63 800/64 200	66 700/67 000
	Machine Weight (Retrofit Configuration) **	kg	55 600	61 400	64 400

* Without tool

** May vary depending on the stick and the bucket

Working Range

Undercarriage		LONG	HVG	ES
A	Maximum allowable angle from vertical	25°	25°	25°
B	Maximum Horizontal Reach	mm	16 400/18 150	16 400/18 150
C	Maximum Pin Height	mm	26 100/27 900	26 200/28 000
	Maximum Tool Weight (over the front)	kg	3300/2500	3300/2500
	Maximum Tool Weight (over the side)	kg	2500/2000	3000/2500

Engine Specs

Engine	Cat C13 with ACERT™ Technology	
Ratings	rpm	1800
Net Power (ISO 9249)	kW/hp	239/325

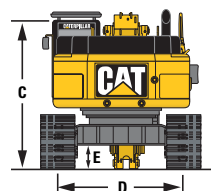
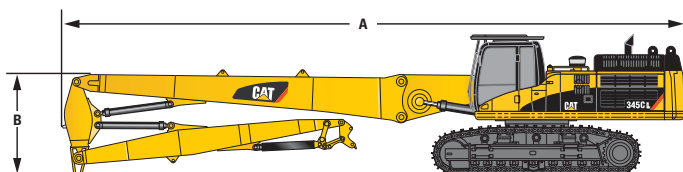

Dimensions and weights

Example: 345C – 26 m version

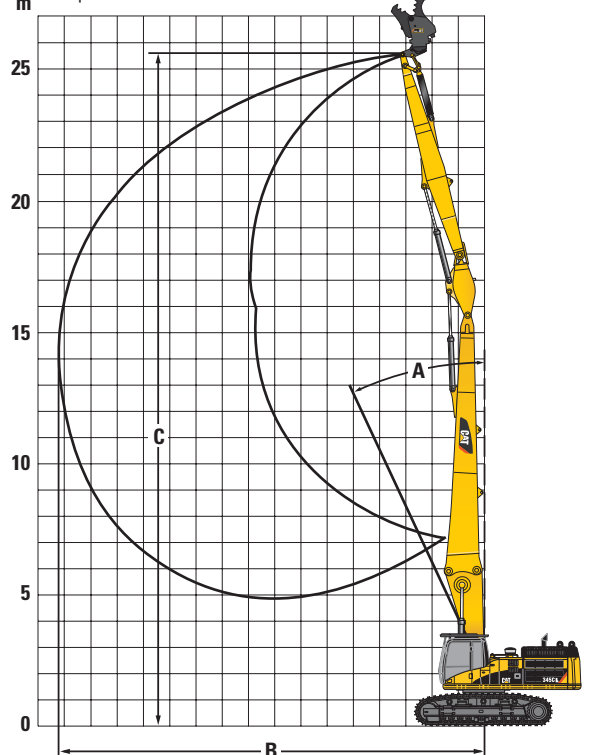

Working range

Specifications – 365C (33 m)

Dimensions and Weights

A	Storage Length	mm	20 720
B	Boom Height	mm	4320
C	Cab Height (with FOGS)	mm	3940
D	Shipping Gauge (retracted position)	mm	2750
D	Working Gauge (extended position)	mm	3510
E	Ground Clearance	mm	890
	Machine Weight (UHD configuration) *	kg	85 690
	Machine Weight (Retrofit Configuration) **	kg	82 930

* Without tool

** May vary depending on the stick and the bucket

Working Range

A	Maximum allowable angle from vertical		25°
B	Maximum Horizontal Reach	mm	21 600
C	Maximum Pin Height	mm	33 100
	Maximum Tool Weight (over the front)	kg	3000
	Maximum Tool Weight (over the side)	kg	2000

Engine Specs

Engine	Cat C15 with ACERT™ Technology	
Ratings	rpm	2000
Net Power (ISO 9249)	kW/hp	302/411

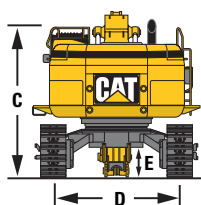
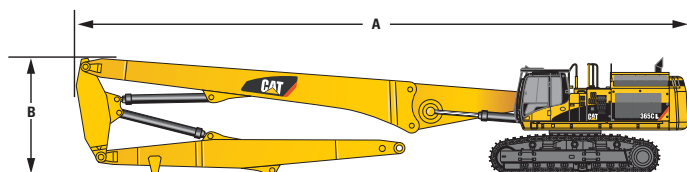

Dimensions and weights

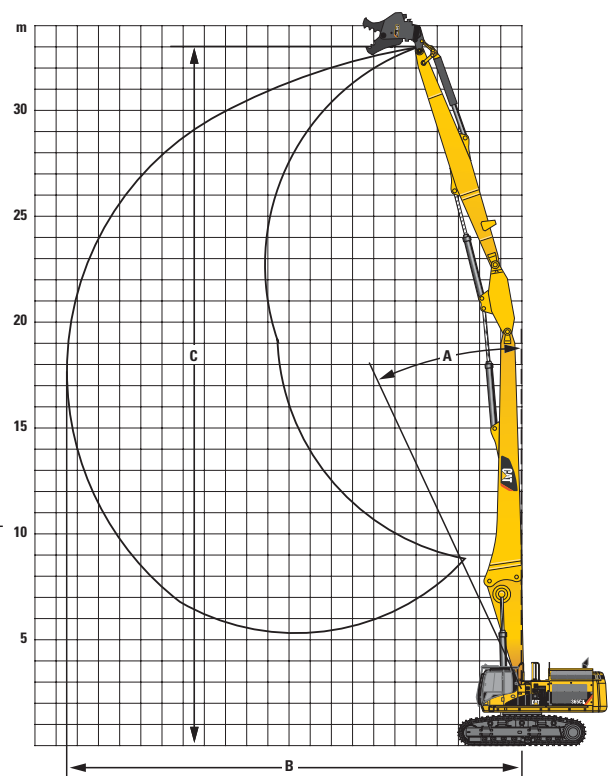

Working range

Specifications – 385C (40 m)

Dimensions and Weights

UHD Version		40 m
A	Storage Length	mm 22 710
B	Boom Height	mm 8120
C	Cab Height (with FOGS)	mm 3950
D	Shipping Gauge (retracted position)	mm 2750
D	Working Gauge (extended position)	mm 3510
E	Ground Clearance	mm 890
	Machine Weight (UHD configuration) *	kg 98 720
	Machine Weight (Retrofit Configuration) **	kg 93 730

* Without tool

** May vary depending on the stick and the bucket

Working Range

UHD Version		40 m
A	Maximum allowable angle from vertical	15°
B	Maximum Horizontal Reach	mm 25 200
C	Maximum Pin Height	mm 39 500
	Maximum Tool Weight (over the front)	kg 2400
	Maximum Tool Weight (over the side)	kg 2100

Engine Specs

Engine	Cat C18 with ACERT™ Technology	
Ratings	rpm	1800
Net Power (ISO 9249)	kW/hp	390/530

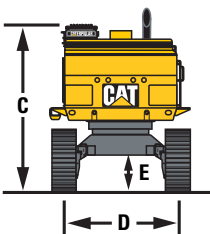
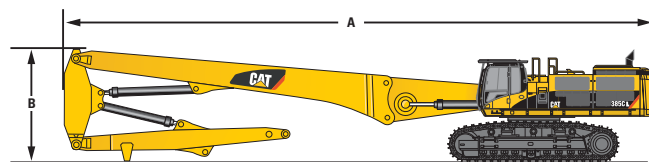

Dimensions and weights

Example: 385C – 40 m version

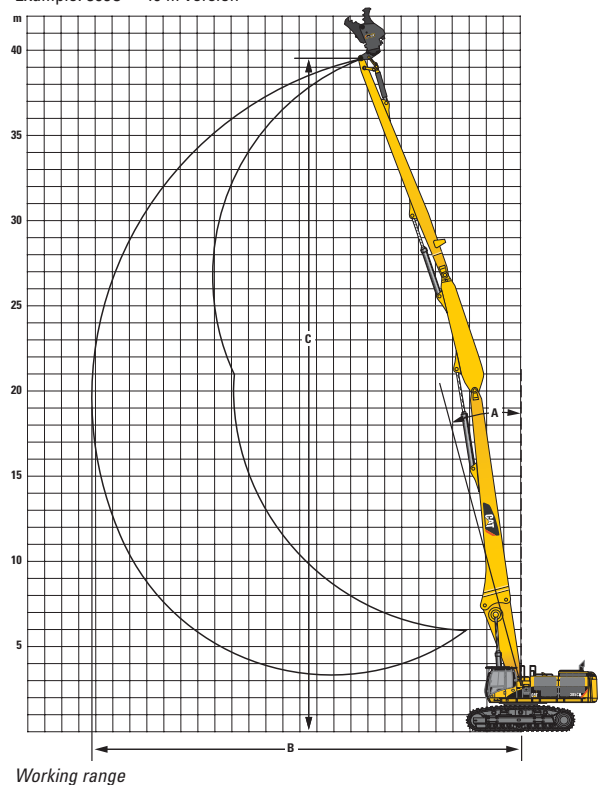

Working range

Specifications – Work Tools

Grapples

Specifications		G320B	G320
Weight	kg	1970*	2060*
Capacity	Liter	750	900
Dimensions			
Length (grapple closed)	mm	1540	1505
Length (grapple open)	mm	2200	2265
Width	mm	1100	1394
Height (grapple closed)	mm	1725	1850
Height (grapple open)	mm	1630	1690
Closing force	kN	66	60
Maximum Oil Flow			
Hydraulic cylinder	l/min	120	100
Rotation	l/min	40	40
Maximum Working Pressure			
Hydraulic cylinder	bar	350	350
Rotation	bar	140	140

* Includes mounting bracket

Quick Couplers

Specifications		CW-40	CW-40 s	CW-45	CW-45 s
Weight (kg)		275	250	400	365
Dimensions	B (mm)	550	420	690	550
	L (mm)	475	475	570	570
Hydraulics	P _{min} (bar)	150	150	150	150
	P _{max} (bar)	350	350	350	350
	Q _{max} (L/min)	40	40	40	40

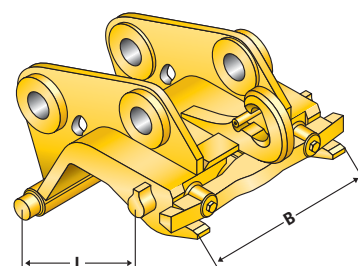

Specifications – Work Tools

Shear Specifications

Specifications		S320	S325
Weight	kg	2150	3000
Dimensions			
Length	mm	3044	3453
Height	mm	1183	1374
Jaw opening	mm	390	490
Jaw depth	mm	440	570
Shear Force			
At tip	kN	900	1250
Primary blade center	kN	2200	3200
At throat	kN	3800	5900
P_{max}	bar	350	350

Hydraulic Requirements

Specifications		S320	S325
Hydraulic for cutting			
Optimum flow	l/min	150	200
Return flow (opening)	l/min	240	300
Speed open	sec	4	5
Speed close	sec	3	3
Connection	BSP	1	1
Speed valve			
Switching pressure	bar	200	200
Oil flow (max)	l/min	200	300
Hydraulic for rotating			
P_{max}	l/min	140	140
Optimum flow	l/min	40	40
Hydromotor		one	one

Concrete Cutter Jaws and Shear Jaws

Specifications and Dimensions

		Concrete Cutter Jaws			Shear Jaws		
		MP15	MP20	MP30	MP15	MP20	MP30
Weight total – housing, jaw and bracket	kg	2020	2660	3850	1950	2570	3890
Weight of the jaw	kg	640	930	1260	570	840	1300
Length	mm	2200	2400	2800	2100	2250	2700
Height	mm	1510	1750	1980	1310	1510	1680
Width	mm	800	800	1010	800	800	1010
Jaw width (fixed)	mm	300	360	380	300	320	370
Jaw width (moving)	mm	100	130	130	80	100	120
Jaw opening	mm	670	820	975	350	420	470
Jaw depth	mm	670	790	890	480	580	710
Cutter-length	mm	400	460	520	400	520	600
Maximum crushing/shear force							
Tooth-jaw tip	kN	700	950	1250	900	1200	1600
Front cutter tip	kN	1000	1400	1850	–	–	–
Primary blade center	kN	2200	3000	4100	2100	2900	3750
At throat	kN	–	–	–	4200	5800	7100
Maximum oil flow							
Hydraulic-cylinder	l/min	150	200	300	150	200	300
Cycle time (open, close, open)	sec	5	6	6.5	5	6	6.5
Rotation	l/min	40	40	40	40	40	40
Maximum working pressure							
Hydraulic-cylinder	bar	350	350	350	350	350	–
Rotation	bar	140	140	140	140	140	–
Cutting Capacity							
Narrow I-beams							
Height	mm	300	400	500	300	400	500
Flange width	mm	150	180	200	150	180	200
Flange thickness	mm	10.7	13.5	16.0	10.7	13.5	16.0
Web thickness	mm	7.1	8.6	10.2	7.1	8.6	10.2
Wide I-beams							
Height	mm	190	250	310	190	250	310
Flange width	mm	200	260	300	200	260	300
Flange thickness	mm	10	12.5	15.5	10	12.5	15.5
Web thickness	mm	6.5	7.5	9.0	6.5	7.5	9.0
Solid-round	mm	65	80	90	65	80	90
Solid-square	mm	60	70	80	60	70	80

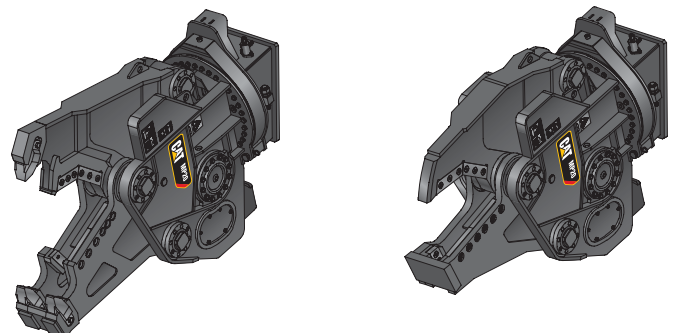

Primary Pulverizer Jaws and Crusher Jaws

Specifications and Dimensions

		Pulverizer Jaws			Crusher Jaws		
		MP15	MP20	MP30	MP15	MP20	MP30
Weight – housing, jaw and bracket	kg	2220	2900	4180	2010	2660	3860
Weight of the jaw	kg	840	1170	1590	630	930	1270
Length	mm	2200	2350	2770	2200	2325	2800
Height	mm	1510	1750	1980	1590	1775	1980
Width	mm	800	800	1010	800	800	1010
Jaw width (fixed)	mm	300	360	380	480	540	610
Jaw width (moving)	mm	100	130	130	280	340	370
Jaw opening	mm	710	850	1050	700	800	960
Jaw depth	mm	700	770	920	700	800	940
Cutter-length	mm	200	260	260	200	200	250
Maximum crushing/shear force							
Tooth-jaw	kN	700	950	1250	650	950	1250
At 2nd tooth	kN	950	1350	1750	900	1300	1550
Primary blade center	kN	2100	2750	3950	2100	2750	3950
Maximum oil flow							
Hydraulic cylinder	l/min	150	200	300	150	200	300
Cycle time (open, close, open)	sec	5	6	6.5	5	6	6.5
Rotation	l/min	40	40	40	40	40	40
Maximum working pressure							
Hydraulic cylinder	bar	350	350	350	350	350	350
Rotation	bar	140	140	140	140	140	140

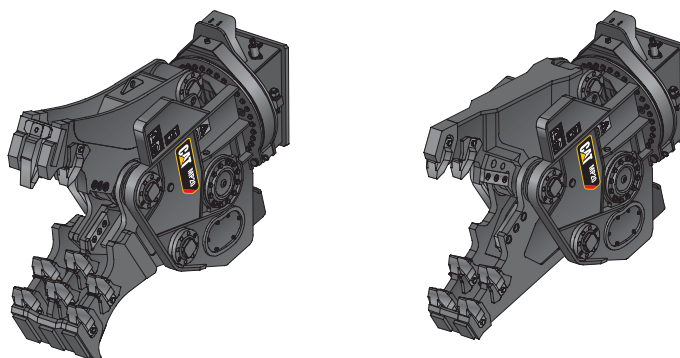

Main Standard Equipment

Standard on all Cat UHD Models

- Reinforced upper frame and heavier counterweight
- Hydraulically tiltable cab (integrated into the upper frame)
- Purpose-designed demolition cab, with impact-resistant front windshield, large high-resistant upper skylight, and FOGS
- Front windshield and top window wipers
- Boom Hook System with Hydraulic Quick Disconnects (325D, 330D) or face-to-face ball valves (345C, 365C, 385C)
- Tool cylinder protection guard (sliding steel box)
- Dedicated UHD tool linkage
- Boom, stick and tool cylinder lowering control devices with Caterpillar SmartBoom™ system and overload warning device

www.cat.com

HEHH3261-2 (03/2007) hr

© 2007 Caterpillar -- All rights reserved. CAT, CATERPILLAR, their respective logos, ACERT™ and 'Caterpillar Yellow', as well as corporate and product identity used herein, are trademarks of Caterpillar and may not be used without permission.

CATERPILLAR®
TODAY'S WORK. TOMORROW'S WORLD.™

Courtesy of Machine.Market