

# 627H

## Wheel Tractor-Scraper



### Engine

Tractor	Cat® C13 ACERT™
Scraper	Cat® C9.3 ACERT™
<b>Tractor Engine</b>	
Max. Power	304 kW    407 hp

### Scraper Engine

Max. Power	216 kW	290 hp
------------	--------	--------

### Scraper Bowl

Heaped Capacity	18.3 m <sup>3</sup>	24 yd <sup>3</sup>
Rated Load	67 040 kg	147,798 lb

## 627H Features

### Economical Hauling System

The wheel tractor-scraper, with its ability to load quickly, haul at high speeds and dump on the go, has the potential to be the most profitable hauling system on the job site. This efficiency can result in fewer machines on the job, reduced operating costs and jobs delivered in a shorter period of time.

### Power Train

Caterpillar designed and manufactured power train components deliver the power necessary for fast loading and quick hauls.

### Operator Station

Single joystick control of implements, adjustable arm rests, seat, steering column and room to maneuver all reduce fatigue and increase operator comfort and productivity throughout the shift.

### Cushion Hitch

The cushion hitch is a Caterpillar proven system for protecting components of the hitch and improving ride quality, dampening loads that might otherwise be carried through the frame to the operator. Cushion hitch offers operators a more comfortable haul portion of the work cycle.

### Durability

Cat wheel tractor-scrapers have a history of robust structural design, tested and validated to last in the most rugged loading and hauling conditions.

### Contents

Operator's Station .....	3
Operator Comfort .....	4
Power Train – Engine .....	5
Power Train – Transmission .....	6
Structures.....	7
Scraper Bowl.....	8
Loading Options.....	9
Integrated Technologies.....	10
Complete Customer Support.....	11
Safety .....	12
627H Wheel Tractor-Scraper Specifications ...	13
627H Standard Equipment .....	18
627H Optional Equipment.....	19



**Quick loading, high travel speeds and the ability to load and dump on the run yield fast cycle times, allowing Cat Wheel Tractor-Scrapers to consistently deliver high productivity at the lowest cost per ton.**



# Operator's Station

Ergonomically designed for all-day comfort, control and productivity.

## Ergonomic Layout

The all new H Series operator station is ergonomically designed for total machine control in a comfortable, productive and safe environment. All controls, levers, switches and gauges are positioned to maximize productivity and facilitate a reduction in operator fatigue.

## Viewing Area

Designed for excellent all-around visibility and clear sight lines to the job site, the large viewing area offers exceptional visibility to the front of the machine as well as to the cutting edge. The air conditioning unit has been relocated to beneath the cab, allowing the operator enhanced visibility.

1) Angled Steering Wheel for enhanced comfort while loading. 2) Lunchbox Storage Platform with Strap. 3) Sequence Assist, Load Assist, and Cat® Grade Control Controls (optional). 4) Work Area Vision System (WAVS) (optional). 5) Cat Messenger Display. 6) Implement Control Lever. 7) Cat Grade Control Display (optional). 8) Transmission Controls. 9) Cat Comfort Seat. 10) Coat Hook. 11) Dome Courtesy Light. 12) Rearview Mirror. 13) Radio-Ready. 14) Heating and Air Conditioning.

# Operator Comfort

High productivity from a comfortable, confident operator.



## Spacious Cab

With a 21% larger cab, H Series scrapers offer a comfortable working space. The larger cab and wider door make getting in and out of the cab easier. The increased glass area enhances visibility around the machine.

## Steering Column

The steering column and pedals have been relocated for more comfortable operation when the seat is angled during machine operation. The telescopic and tilt adjustable steering column maintains a comfortable driving position regardless of operator size.

## Standard Comfort Features

The H Series cab is equipped with features designed to maintain operator comfort. Standard comfort features include: coat hook, lunchbox storage platform with strap, air conditioning, heat, and radio-ready.

## Seat Options

H Series scrapers use the Cat Comfort Seat with additional travel to allow the operator to position themselves for optimal comfort and productivity. The seat rotates up to 30 degrees to the right for a more comfortable position during loading and 30 degrees to the left to make getting in and out of the cab easier.

For unparalleled ride comfort, H Series scrapers are equipped with the Cat Advanced Ride Management (ARM) seat suspension which uses an active suspension to dampen vibration and minimize end-of-stroke shock loads to the operator.

## Integrated Technologies

The optional Sequence Assist, Load Assist, and Cat Grade Control automate many repetitive operator tasks.

## T-Handle Implement Control Lever

The redesigned control lever puts all of the scraper functions in the palm of the operator's hand. The low-effort lever and convenient push-button and thumb wheel controls are ergonomically placed for minimum arm movement.

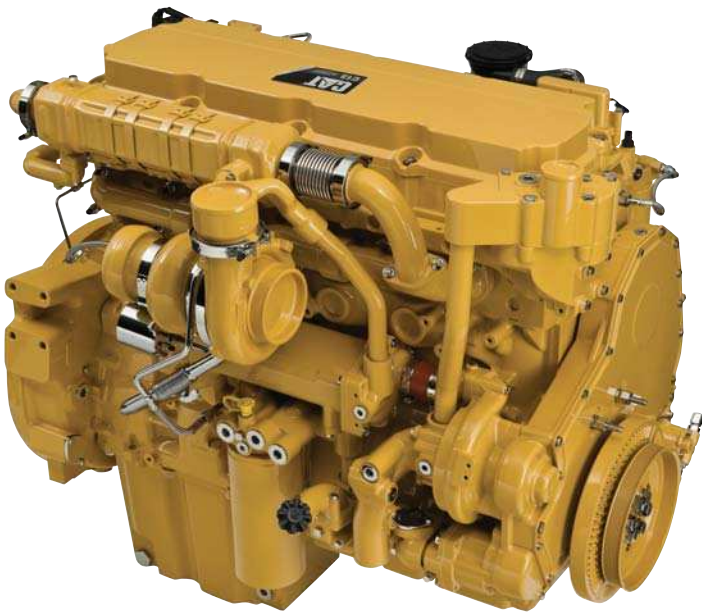

# Power Train – Engine

The Cat® C13 ACERT™ and C9.3 ACERT engines are built for power, reliability and efficiency.

## **ACERT Technology**

The Cat® C13 ACERT™ engine in the tractor and C9.3 ACERT engine in the scraper continue the evolutionary, incremental improvements that provide breakthrough engine technology built on systems and components developed by Caterpillar with proven reliability. Both engines are available with either U.S. EPA Tier 3/EU Stage IIIA equivalent emission configurations or U.S. EPA Tier 4 Interim/EU Stage IIIB certified emission configurations to meet the needs of contractors around the world.

## **Emissions**

Machines equipped with engines meeting U.S. EPA Tier 4 Interim/EU Stage IIIB emission standards are equipped with a Cat Clean Emission Module to deliver the performance and efficiency that customers demand while meeting emission requirements. Machines equipped with the U.S. EPA Tier 3/EU Stage IIIA equivalent engines are equipped with a muffler in place of the Cat Clean Emission Module.

## **Cat Clean Emission Module (CEM)**

CEM is an exhaust aftertreatment package consisting of a diesel particulate filter, and control systems. The CEM reduces particulate emissions using passive and active regeneration during normal engine operation.

## **Cat NO<sub>x</sub> Reduction System (NRS)**

The Cat NO<sub>x</sub> Reduction System (NRS) captures and cools a small quantity of exhaust gas, then routes it into the combustion chamber where it drives down combustion temperatures and reduces NO<sub>x</sub> emissions.

## **Diesel Particulate Filter Regeneration**

Regeneration is the removal of soot from the Diesel Particulate Filter (DPF). The Aftertreatment Regeneration Device (ARD) is used to regenerate the DPF. The DPF traps both particulates and ash, the ash is removed at regular service intervals.

# Power Train – Transmission

More power to the ground for greater productivity.

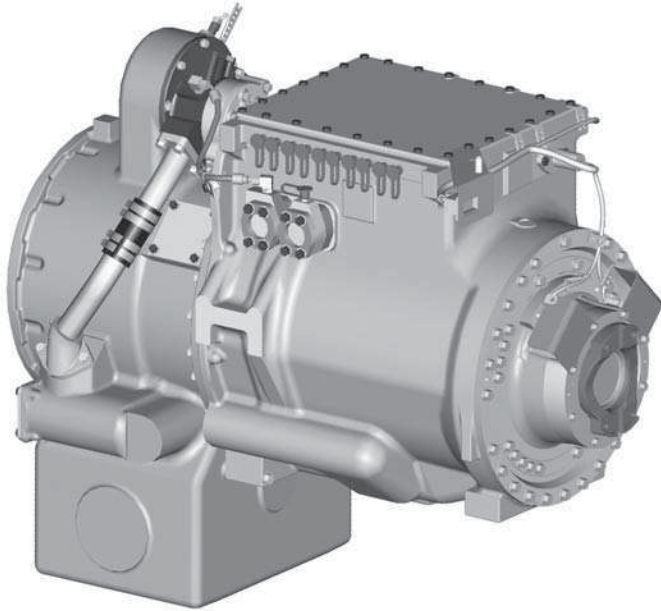

## Electronic Transmission

The Cat eight-speed forward one-speed reverse Electronic Clutch Pressure Controlled (ECPC) transmission features enhanced shift control logic with anti-hunt shift strategy for speed continuity, and to ensure constant shift times.

- Tractor gears 1-2 – converter drive for increased torque, gears 3-8 – direct-drive for drive train efficiency. Scraper gears use converter drive for more torque in the cut.
- Transmission Hold maintains converter drive for maximum rimpull or holds current gear for best control.
- Programmable Top Gear manually sets top gear available (3rd-8th) to match conditions or speed.
- Neutral Coast Inhibitor prevents transmission shifts into neutral while moving.

## Smooth Transmission Gear Shifting

The 627H features ECPC Shift Torque Management (STM), with improved Shift Control Logic (SCL) and Part Throttle Shifting (PTS). These features allow smoother shifting and greater acceleration on grades while torque is maintained through the shift changes. SCL also provides automatic shift selection that is more specific to the desired machine operation, and downshifts when needed for maximum acceleration when increased throttle is applied. PTS allows shifting at lower speeds during part throttle operation, resulting in improved part throttle fuel economy, quieter machine operation, and better maneuvering in reduced speed operating conditions.

## Brake Performance

The 627H uses hydraulically-actuated wet disc brakes for exceptional brake performance. The standard Cat Engine Brake reduces brake wear and enhances machine control.

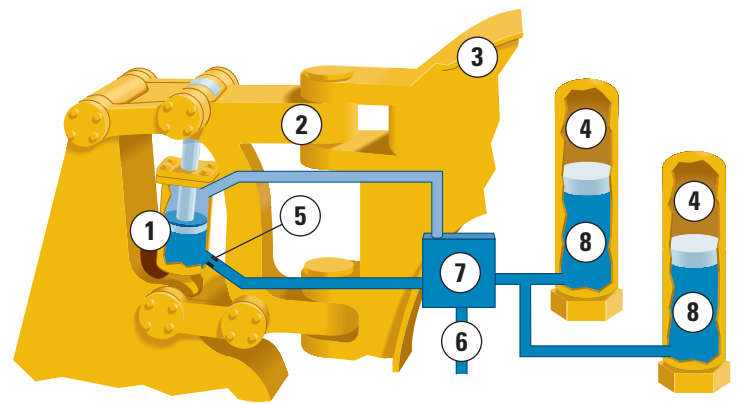

# Structures

Superior design and construction delivers long term durability.

## Cushion Hitch

Electronically actuated with parallelogram-type linkage for exceptional strength, with two nitrogen accumulators (4) using free-floating pistons (8) to deliver a smooth ride for enhanced operator comfort and machine durability.

- controlled oil flow (6) dampens rebound oscillation
- leveling valve (7) applies pressure via an orifice (5) to automatically center the piston in load cylinder (1)
- steel castings are used to eliminate many welded joints and increase strength
- double-kingbolt design (2, 3) withstands high external forces, simplifies installation and removal

## Lockout Switch

An operator-selectable lockout switch, located on the joystick, locks the cushion hitch down for improved control of the cutting edge during loading and dumping.

## Nitrogen Accumulator

Vertically mounted hydraulic cylinder transfers road shocks to nitrogen accumulators. Nitrogen accumulator absorbs and dampens road shocks, thus preventing the loads from being transmitted to the hitch components or to the operator.

## Non-Metallic Fenders and Fuel Tank

The new fuel tank is made of recyclable roto-milled polyethylene and keeps the fuel cleaner with controlled filtration and cleanout access ports. The new fuel tanks have increased capacities, providing operators with 10 plus hour shifts depending on engine load factors.

The new tractor fenders are made of the same highly durable, roto-milled polyethylene. The non-metallic fenders prevent material buildup when operating in sticky materials.



# Scraper Bowl

Caterpillar designed and built for rugged performance and reliability.

## **Redesigned Bowl**

The 627H uses a new bowl design that enhances productivity through a 9% increase in bowl capacity over previous models. The low profile design offers low resistance to incoming materials, while cellular construction adds strength and dent resistance to the bowl sides and floor.

## **Hydraulic Lines Protection**

Hydraulic lines durability is increased by routing them through the bowl sidewalls where they are protected from damage on the job site.

## **Ejection System**

The powerful ejection system provides constant spreading control while minimizing carryback material. An overflow guard on the ejector helps retain material and keep it from spilling over onto the rear of the scraper.

## **Cutting Edges and Cat Ground Engaging Tools (GET)**

A variety of Ground Engaging Tools (G.E.T.) options are available to optimize the machine for different material types and loading conditions. GET options include standard, serrated, and abrasion resistant material (ARM). Most are reversible to provide long life and reduced operating costs.



# Loading Options

Flexible loading options to adapt to changing job site conditions.

## Self-Loading

The 627H is an excellent self-loading hauling system using the combined power of two engines to quickly and efficiently load the bowl in most materials.

## Push-Loading

To prevent tire wear in abrasive material, the 627H can be push-loaded with a D8- or D9-size Track-Type Tractor.

## Push-Pull

The push-pull arrangement is recommended for applications that require a large amount of material to be moved very quickly at low cost per bank cubic meter (bank cubic yard). The push-pull arrangement concentrates the combined power of two machines onto one cutting edge. Push-pull scrapers work in pairs where the lead scraper is pushed through the cut by the trailing scraper. When the lead scraper is fully loaded, the trailing scraper lowers its bowl and is pulled through the cut by the lead scraper. The result is a self-loading system.

The push-pull arrangement features a hydraulically-actuated bail and cushioned plate, which are bolted to the front of the tractor, and a hook that is attached to the rear of the scraper. Working together, push-pull scrapers can provide the lowest cost per meter (yard) for many applications.



# Integrated Technologies

Technology options to improve operator comfort and increase productivity.



## Sequence Assist

Sequence Assist uses integrated software and position-sensing cylinders to automate many of the tasks an operator performs when loading, hauling and dumping. The operator simply sets preferences for bowl and apron height and subsequently pushes a button to ready the machine for loading, then hauling, then dumping, and then the return to cut. The system automatically sets the cushion hitch, bowl height, apron and ejector. Sequence Assist comes with a convenient load counter for tracking material moved.

With Sequence Assist, up to 14 individual implement and machine commands are replaced by four touches of a button, allowing the operator additional time to prepare for the loading cycle and observation of the job site.



## Load Assist

Load Assist builds on Sequence Assist by loading the bowl with the push of a button. As the machine enters the cut, the operator can activate Load Assist so the system takes over control of the cutting edge height, limiting tire spin based on integrated sensors and GPS technology to ensure consistent and full bowl loads. The operator is responsible only for the throttle, steering, and operating the apron. Load Assist helps make inexperienced operators productive very quickly.

## Cat Grade Control

Cat Grade Control is an automatic system that helps you control costs by moving the maximum amount of material with the prime earthmover which often provides the lowest cost per unit of material moved. Using satellite positioning technology, the automatic system ensures cut protection by limiting how deep the scraper will dig. The optional system is available from the factory and fully integrated into the machine and works seamlessly with Sequence Assist and Load Assist.

Additional benefits of Cat Grade Control include putting the site plan in front of the operator for increased efficiency and elimination of rework and using the scraper for site mapping.



## Work Area Vision System (WAVS)

Cameras on the machine provide views of the cutting edge, right side and rear. The system enhances safety and provides a new way to see the cutting edge during loading and to see to the rear of the machine when performing push-load or push-pull work with another scraper.



# Complete Customer Support

Cat<sup>®</sup> dealer services help you operate longer with lower costs.

## **Selection**

Make comparisons of the machines you are considering before you buy. Your Cat<sup>®</sup> dealer can help.

## **Purchase**

Consider the resale value, compare productivity and day-to-day operating costs and fuel consumption.

## **Operation**

For the best operating techniques to increase productivity and your profit, turn to your Cat dealer for the latest training literature and trained staff.

## **Maintenance**

Repair option programs guarantee the cost of repairs up front. Diagnostic programs such as S-O-S<sup>SM</sup> and Technical Analysis help you avoid unscheduled repairs.

## **Replacement**

Repair or rebuild? Your Cat dealer can help you evaluate the costs so you can make the right choice.

## **Product Support**

Your local Cat dealership will be with you every step of the way with its unsurpassed worldwide parts support, trained technicians and customer support agreements.

## **cat.com**

For more complete information on Cat products, dealer services and industry solutions, visit us on the web at [www.cat.com](http://www.cat.com)



# Safety

Safety is an integral part of all machine and system designs.

## **Powered Access Ladder**

A new powered access system option significantly reduces the effort required to climb into the cab. The system is a solid, stable angled ladder that folds out from underneath the cab. It is activated from a keypad located behind a service door at ground level. Controls are also located in the cab on a keypad.

The ladder provides a rigid and angled base of support for easier climbing and descent. For added safety, the steps are illuminated by LED lights.

An actuator under the cab operates the step. When not in use, the ladder retracts under the cab. An audible alarm sounds if the machine moves while the ladder is down. If power fails on the machine, the operator can raise or lower the steps manually using a lever inside the cab or outside next to the ladder's top step.

## **Access and Egress**

Handrails and grab irons are provided for safe and secure entrance and exit of the cab as well as for performing daily maintenance.

## **Work Area Vision System (WAVS)**

Cameras on the machine provide views of the cutting edge, right side and rear. The system enhances safety and provides a new way to see the cutting edge during loading and to see to the rear of the machine when performing push-load or push-pull work with another scraper.

# 627H Wheel Tractor-Scraper Specifications

## Tractor Engine – U.S. EPA Tier 4 Interim/EU Stage IIIB

Tractor Engine	Cat® C13 ACERT™	
Max. Power (All Gears) (ISO 14396)	304 kW	407 hp
Max. Power Reference Engine Speed	1,700 rpm	
Displacement	12.5 L	763 in <sup>3</sup>
Bore	130 mm	5.1 in
Stroke	157 mm	6.2 in

- Max. power advertised is the max. power available at max. power reference engine speed of 1,700 rpm, measured at the flywheel when the engine is equipped with air cleaner, alternator, and exhaust losses.

## Tractor Engine – Prior U.S. EPA Tier 3/EU Stage IIIA configuration\*

Tractor Engine	Cat® C13 ACERT™	
Max. Power (All Gears) (ISO 14396)	304 kW	407 hp
Max. Power Reference Engine Speed	1,700 rpm	
Displacement	12.5 L	763 in <sup>3</sup>
Bore	130 mm	5.1 in
Stroke	157 mm	6.2 in

- Max. power advertised is the max. power available at max. power reference engine speed of 1,700 rpm, measured at the flywheel when the engine is equipped with air cleaner, alternator, and exhaust losses.

\* For jurisdictions other than the U.S. and the European Union.

## Scraper Engine– U.S. EPA Tier 4 Interim/EU Stage IIIB

Tractor Engine	Cat® C9.3 ACERT™	
Max. Power (All Gears) (ISO 14396)	216 kW	290 hp
Max. Power Reference Engine Speed	1,900 rpm	
Displacement	9.29 L	567 in <sup>3</sup>
Bore	115 mm	4.5 in
Stroke	149 mm	5.9 in

- Max. power advertised is the max. power available at max. power reference engine speed of 1,900 rpm, measured at the flywheel when the engine is equipped with air cleaner, alternator, and exhaust losses.

## Scraper Engine – Prior U.S. EPA Tier 3/EU Stage IIIA configuration\*

Tractor Engine	Cat® C9 ACERT	
Max. Power (All Gears) (ISO 14396)	216 kW	290 hp
Max. Power Reference Engine Speed	1,900 rpm	
Displacement	9.29 L	567 in <sup>3</sup>
Bore	115 mm	4.5 in
Stroke	149 mm	5.9 in

- Max. power advertised is the max. power available at max. power reference engine speed of 1,900 rpm, measured at the flywheel when the engine is equipped with air cleaner, alternator, and exhaust losses.

\* For jurisdictions other than the U.S. and the European Union.

## Scraper Bowl

Heaped Capacity	18.4 m <sup>3</sup>	24 yd <sup>3</sup>
Rated Load	26 127 kg	57,600 lb
Struck Capacity	13 m <sup>3</sup>	17.1 yd <sup>3</sup>
Maximum Depth of Cut	315 mm	12.4 in
Width of Cut, Outside Router Bits	3136 mm	123.5 in
Maximum Ground Clearance at Cutting Edge	594 mm	23.4 in
Thickness of Cutting Edge	22 mm	0.9 in
Maximum Hydraulic Penetration Force	580 kN	130,390 lbf
Maximum Depth of Spread	540 mm	21.3 in
Maximum Apron Opening	1767 mm	69.6 in
Maximum Apron Closure Force	225 kN	50,580 lbf

## Transmission

1 Forward	5.0 km/h	3.1 mph
2 Forward	8.9 km/h	5.5 mph
3 Forward	12.1 km/h	7.5 mph
4 Forward	16.3 km/h	10.1 mph
5 Forward	21.9 km/h	13.6 mph
6 Forward	29.6 km/h	18.4 mph
7 Forward	39.9 km/h	24.8 mph
8 Forward	53.9 km/h	33.5 mph
Reverse	9.2 km/h	5.7 mph

# 627H Wheel Tractor-Scraper Specifications

Hydraulics		
Bowl Cylinder Bore	140 mm	5.5 in
Bowl Cylinder Stroke	845 mm	33.3 in
Apron Cylinder Bore	150 mm	5.9 in
Apron Cylinder Stroke	565 mm	22.2 in
Ejector Cylinder Bore	140 mm	5.5 in
Ejector Cylinder Stroke	1550 mm	61.0 in
Push/Pull Bail Cylinder Bore	90 mm	3.5 in
Push/Pull Bail Cylinder Stroke	415 mm	16.3 in
Steering Circuit Flow	234 L/min	61.8 gal/min
Secondary Steering Circuit Flow	39.0 L/min	10.3 gal/min
Scraper Circuit Flow	250 L/min	66.0 gal/min
Cushion Hitch Circuit Flow	40.1 L/min	10.6 gal/min

## Service Refill Capacities – Tractor

Engine Crankcase	33 L	8.75 gal
Transmission	70 L	18.5 gal
Differential	173 L	45.8 gal
Final Drive (per side)	19 L	5.0 gal
Cooling System	64 L	17.0 gal
Hydraulic Reservoir	83 L	22.0 gal
Windshield Washer Reservoir	5 L	1.3 gal

## Service Refill Capacities – Scraper

Engine Crankcase	28 L	7.5 gal
Transmission	49 L	13.0 gal
Differential	53 L	14.0 gal
Final Drive (per side)	19 L	5.0 gal
Cooling System	72 L	19.0 gal
Fuel Tank	1272 L	336.0 gal

Steering	
Steering Angle – Right	85°
Steering Angle – Left	82°

## Weights

Machines meeting U.S. EPA Tier 4 Interim/ EU Stage IIIB emission standards

Standard		
Shipping Weight – 10% Fuel	39 899 kg	87,962 lb
Operating Weight – full fuel tanks	40 913 kg	90,198 lb
Loaded, based on a rated load	67 040 kg	147,798 lb
Push-Pull		
Shipping Weight – 10% Fuel	41 154 kg	90,729 lb
Operating Weight – full fuel tanks	42 168 kg	92,964 lb
Loaded, based on a rated load	68 295 kg	150,565 lb

Machines achieving prior U.S. EPA Tier 3/ EU Stage IIIA emissions levels

Standard		
Shipping Weight – 10% Fuel	39 486 kg	87,052 lb
Operating Weight – full fuel tanks	40 500 kg	89,287 lb
Loaded, based on a rated load	66 627 kg	146,887 lb
Push-Pull		
Shipping Weight – 10% Fuel	40 741 kg	89,818 lb
Operating Weight – full fuel tanks	41 722 kg	91,981 lb
Loaded, based on a rated load	67 882 kg	149,654 lb

## Standards

- Steering System meets ISO 5010:2007 for up to a maximum approved operating weight
- Brakes meet ISO 3450:1996 for up to a maximum approved operating weight
- Rollover Protective Structure (ROPS) is certified to a tractor only mass of 18 800 kg (41,447 lb) as tractor portion of tractor-scrappers per Table 1 of ISO 3471:2008. This excludes scraper weight and payload.
- Falling Object Protective Structure (FOPS) meets ISO 3449:2005 Level II
- Seat Belts meet SAE J386 June 1985
- Forward and Reverse Alarms meet ISO 9533:1989
- The dynamic operator sound pressure level is 76 dB(A) when “ISO 6396:2008” is used to measure the value for an enclosed cab. The measurement was conducted at 100% of the maximum engine cooling fan speed. The sound level may vary at different engine cooling fan speeds. The cab was properly installed and maintained. The measurement was conducted with the cab doors and the cab windows closed. The cab was properly installed and maintained. Hearing protection may be needed when the machine is operated with an open operator station for extended periods or in a noisy environment. Hearing protection may be needed when the machine is operated with a cab that is not properly maintained or when the doors and windows are open for extended periods or in a noisy environment.
- The average exterior sound pressure level is 80 dB(A) when the “SAE J88 FEB06 – Constant Speed Moving Test” procedure is used to measure the value for the standard machine. The measurement was conducted under the following conditions: distance of 15 m (49.2 ft) and “the machine moving forward in an intermediate gear ratio.”
- The exterior sound power level is 113 dB(A) when the value is measured according to the static pressure test procedures and the conditions that are specified in “ISO 6393:2008.”

## Dimensions

All dimensions are approximate.

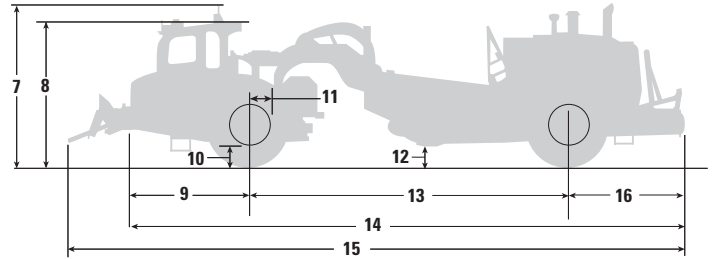

	mm	in
<b>1</b> Width – overall machine	3565	140.4
<b>2</b> Width – tractor (ladder down)	3688	145.2
<b>3</b> Width – tractor	3381	133.1
<b>4</b> Width – rear tire centers	2290	90.2
<b>5</b> Width – inside bowl	3048	120.0
<b>6</b> Width – outside rear tires	3165	124.6
<b>7</b> Height – overall shipping	4029	158.6
<b>8</b> Height – top of cab	3612	142.2

	mm	in
<b>9</b> Front of tractor to front axle	3119	122.8
<b>10</b> Ground clearance, tractor	557	21.9
<b>11</b> Axle to vertical hitch pin	540	21.3
<b>12</b> Height – scraper blade maximum	540	21.3
<b>13</b> Wheelbase	7998	314.9
<b>14</b> Length – overall machine (standard)	14 015	551.8
<b>15</b> Length – maximum (push-pull)	15 575	613.2
<b>16</b> Rear axle to rear of machine	2898	114.1

## 627H Rimpull

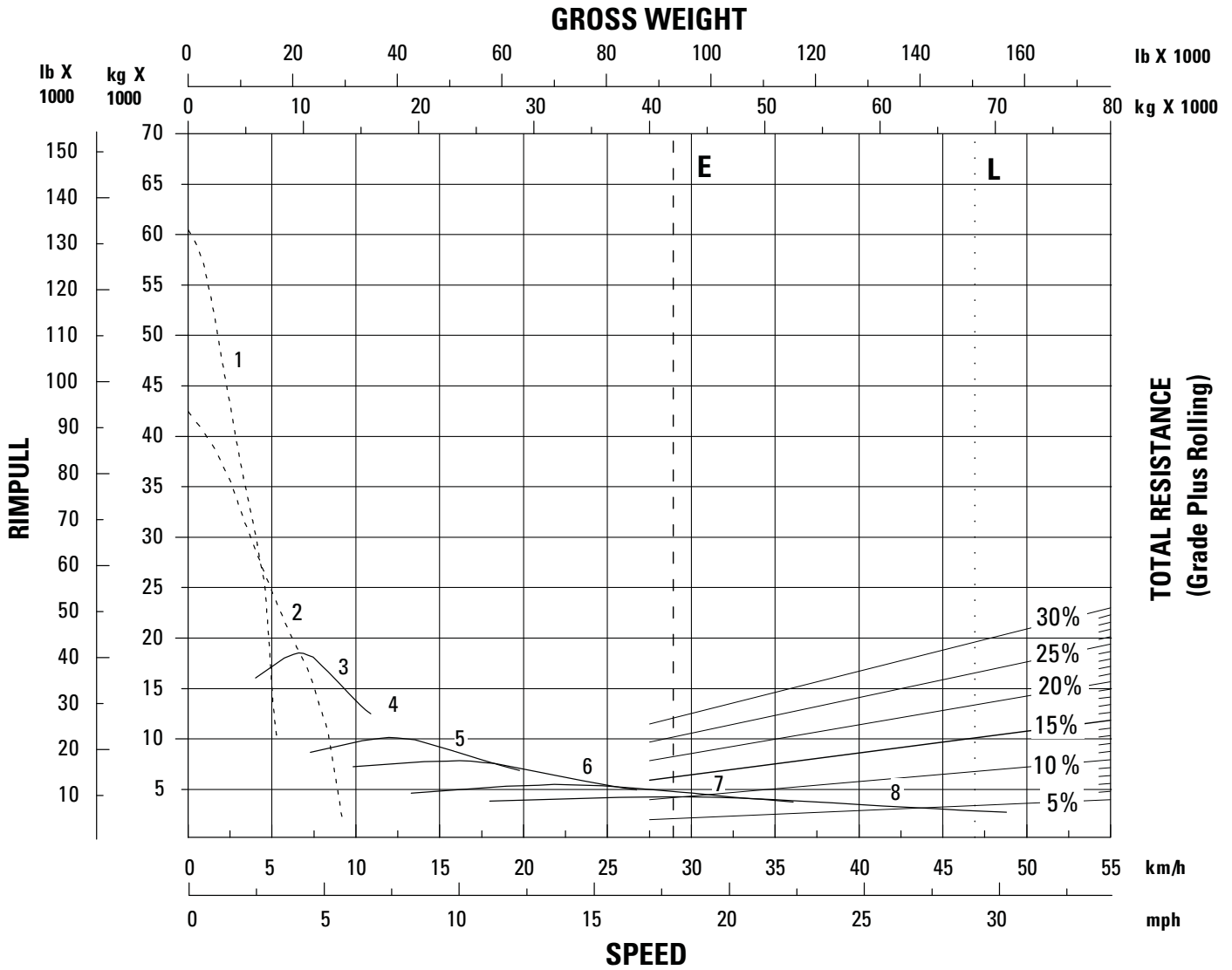



# 627H Retarding\*

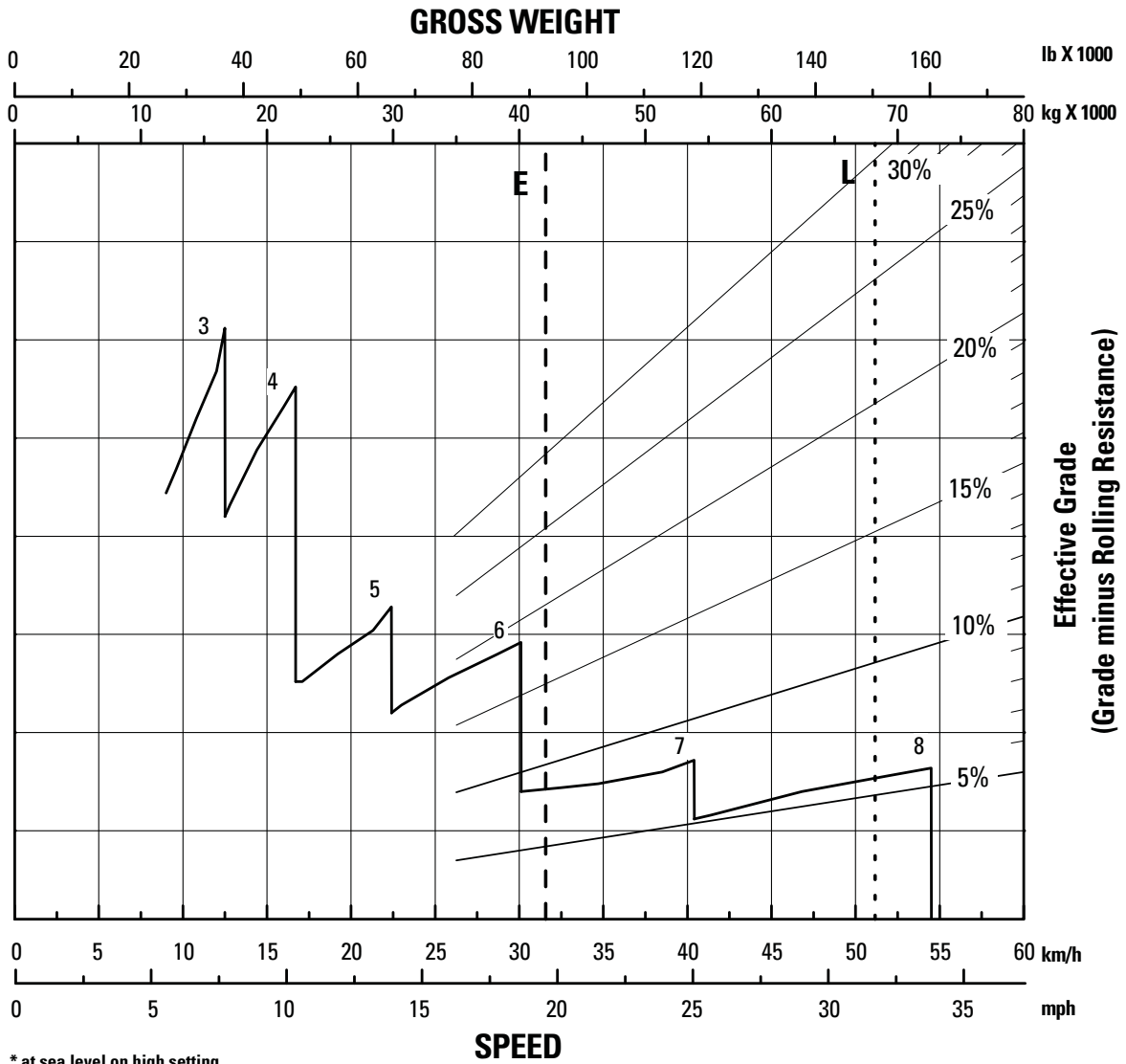

# 627H Standard Equipment

Standard equipment may vary. Consult your Cat dealer for details.

## POWER TRAIN

### TRACTOR:

- C13 ACERT engine with MEUI
- Cat Engine Brake
- Electric start, 24 Volt
- Air cleaner, dry type with precleaner
- Fan, hydraulic
- Diesel Particulate Filter (DPF) aftertreatment (for engine meeting U.S. EPA Tier 4 Interim/EU Stage IIIB emission standards)
- Ground level engine shutdown
- Radiator, aluminum unit core, 9 fins per inch
- Guard, crankcase
- Muffler (for engines achieving U.S. EPA Tier 3/EU Stage IIIA emission levels)
- Starting aid, ether
- Braking system:
  - Primary and Secondary, wet disc, hydraulic
- Parking, hydraulically-released, spring-applied
- Throttle Lock
- Transmission:
  - 8-speed planetary powershift
- ECPC Control
- APECS software
- Programmable top gear selection
- Transmission hold
- Differential lock
- Guard, power train

### SCRAPER:

- C9.3 ACERT engine with high pressure common rail fuel
- Cat Engine Brake
- DPF aftertreatment module (for engine meeting U.S. EPA Tier 4 Interim/EU Stage IIIB emission standards)
- Electric start, 24 volt
- Fan, driveline
- Ground engine shutdown
- Muffler (for engines achieving prior U.S. EPA Tier 3/EU Stage IIIA emission levels)
- Starting aid, ether
- Braking system:
  - Primary and Secondary, wet disc, hydraulic
- Parking, hydraulically-released, spring-applied
- 4-speed (torque converter drive) transmission, planetary powershift

## ELECTRICAL

### TRACTOR:

- Alternator, 150 Amp
- Batteries (4), 12 Volt, 1,000 CCA, maintenance free, high output
- Electrical system, 24V
- Lighting system:
  - Headlights, halogen
  - Turn signals with hazard function
- LED Floodlights, halogen (2), cutting edge (1), bowl (2), side vision (2)
- Starting/charging receptacle

### SCRAPER:

- Alarm, backup
- Alternator, 65 Amp
- Batteries (4), 12 Volt, 1,000 CCA, maintenance free, high Output
- Lighting system:
  - Brake lights, LED
  - Turn signals with hazard function, LED
- Starting/charging receptacle

## OPERATOR ENVIRONMENT

### TRACTOR:

- HVAC system, heat, AC, defrost
- Thermostat control of HVAC system
- Coat hook
- Lunchbox platform with holding strap
- Diagnostic connection (2)
- 12V power ports (2)
- Differential lock (1)
- Dome courtesy light
- Horn, electric
- T-Handle implement control
- Mirror, rearview
- Radio ready, 12V
- ROPS/FOPS cab, pressurized
- Keypad switches
- Safety tab rocker switches
- Parking brake
- Seat belt, static two-piece
- Seat, air suspension, Comfort Series 3, rotates 30 degrees
- Steering wheel, tilt, telescoping, padded
- Storage in dash if WAVS or Cat Grade Control is not equipped
- Windows, right side emergency egress
- Windows, sliding
- Windows, laminated, zipped in
- Windshield wipers, front and rear windows, includes washers
- Door lock

Messenger Display – gauges,

warnings include:

- Coolant temp
- Engine oil temp
- Hydraulic oil temp
- DPF temp
- Fuel level
- Park brake
- Implement lockout
- Brake system
- Regeneration required
- Throttle lock
- System voltage
- Secondary steering
- Bail down
- Differential lock
- Apron float
- Transmission hold
- Cushion hitch
- High beam lights
- Action lamp
- Engine speed, rpm
- Gear selection out
- DPF fill levels

## FLUIDS

Extended Life Coolant to  $-37^{\circ}\text{C}$  ( $-34^{\circ}\text{F}$ )

## OTHER STANDARD EQUIPMENT

### TRACTOR:

- Cushion hitch
- Accumulators (cushion hitch) with Canadian Registration Number (CRN)
- Fast oil change
- Fenders, non metallic
- Heater, engine coolant 120V
- Tow pin, front
- Vandalism locks

### SCRAPER:

- Quick drop bowl valve
- Fast oil change
- Vandalism locks
- Guard, Overflow
- Heater, engine coolant 120V
- Extended push block

Optional equipment may vary. Consult your Cat dealer for details.

Push-pull arrangement

Sequence Assist

Load Assist

Cat Grade Control

Secondary Steering

Powered access ladder

Cat Active Ride Management (ARM) seat

Fast fuel fill

HID Work lights

Low ambient fluids  $-51^{\circ}\text{C}$  ( $-61^{\circ}\text{F}$ )

Work Area Vision System (WAVS) –  
three cameras showing right side, cutting edge  
and directly behind machine, display in cab

External steering lock

Cab precleaner

Cab rotating beacon

Air horn

# 627H Wheel Tractor-Scraper

For more complete information on Cat products, dealer services, and industry solutions, visit us on the web at [www.cat.com](http://www.cat.com)

© 2012 Caterpillar Inc.  
All rights reserved

Materials and specifications are subject to change without notice. Featured machines in photos may include additional equipment. See your Cat dealer for available options.

CAT, CATERPILLAR, SAFETY.CAT.COM, their respective logos, "Caterpillar Yellow" and the "Power Edge" trade dress, as well as corporate and product identity used herein, are trademarks of Caterpillar and may not be used without permission.

AEHQ6716 (03-2012)



*Courtesy of Machine.Market*