

631G/637G

Wheel Tractor Scrapers



Engine

Tractor Engine	Cat® C18 ACERT™	
Net Power	345/373 kW	462/500 hp
Scraper Engine	Cat C9 ACERT	
Net Power	198/211 kW	266/283 hp

Scraper Bowl

Heaped Capacity	26 m³	34 yd³
Rated Load	37 285 kg	82,200 lb

631G/637G Wheel Tractor Scrapers

Power Train – Engine

- ✓ The C18 and C9 engines with ACERT™ Technology work at the point of combustion to optimize engine performance and minimize exhaust emissions. Matched with the torque converter and power shift transmission, they provide years of dependable and efficient service. **pg. 4**

Power Train – Transmission

- ✓ Electronic controls switch from converter drive to direct drive based on gear selection, maximizing efficiency and power application. Tractor and scraper engines are synchronized for smooth operation and longer service life. **pg. 6**

Structures

Superior structural design delivers state-of-the-art ride, capacity, and material control while assuring the durability and reliability customers expect from Caterpillar. **pg. 7**

Push-Pull Arrangement (637G only)

For maximum production capability, Caterpillar offers an optional push-pull arrangement for the 637G, which allows two push-pull scrapers to act as a self-loading machine. **pg. 12**

Auger Arrangement

Provides self-loading capability with the same wide material appetite as an open bowl machine. **pg. 13**

Quick loading, high travel speeds and the ability to load and dump on the run yield fast cycle times, allowing Caterpillar® Wheel Tractor-Scrapers to consistently deliver high productivity.



Operator Station

- ✓ Convenient control placement and a comfortable work environment are keys to high productivity. Features include electro-hydraulic controls, an available air seat suspension and advanced instrumentation. **pg. 8**

Electronic Controls

The electronic controls respond to operator commands and input from on-board sensors to optimize machine performance. In addition, the electronic controls provide advanced diagnostic capabilities that result in better machine availability. **pg. 10**

Scraper Bowl

- ✓ Caterpillar® Scraper bowls are designed for excellent material flow and retention for fast cycle times and high productivity. **pg. 11**

Serviceability

- ✓ Grouped service points and easy access, the latest electronic monitoring systems and rugged Caterpillar components simplify maintenance and minimize downtime. **pg. 14**

Customer Support

Caterpillar dealers have the parts and service capabilities to keep your wheel tractor-scraper working. **pg. 15**



✓ *New Feature*

Power Train – Engine

A combination of innovations working at the point of combustion, ACERT™ technology optimizes engine performance while meeting regulations for off-road applications.



Cat C18 Tractor Engine. The tractor for the 631G and 637G is powered by the C18 engine with ACERT™ Technology. The large displacement and high torque rise provides optimal performance in the load, cut, haul and return. Matched to the high efficiency torque converter and electronically controlled power shift transmission, it will provide years of dependable service.

Cat C9 Scraper Engine. The 637G has a C9 engine with ACERT technology that provides additional power to assist in loading as well as improve hauling performance on grades.

ACERT Technology. Caterpillar optimizes engine performance while meeting U.S. EPA Tier 3 and European Union Stage IIIa regulations. ACERT Technology reduces emissions during the combustion process by using advanced technology in the air and fuel systems, in conjunction with integrated electronics. Caterpillar meets emission regulations at the combustion source rather than recycling exhaust gases.

Dual Horsepower. Cat engines have dual horsepower capability with the low power setting in torque converter drive and the high power setting in direct drive. If the auger is engaged while the machine is in torque converter drive, the machine automatically goes to the high power setting.



Electronic unit injector

Mechanical Electronic Unit Injection (MEUI). The MEUI system with variable shaped injection patterns provides for optimum combustion based on altitude and temperature. The Cat MEUI fuel system is a highly evolved fuel system with a proven record of reliability in the field. The system combines the technical advancement of an electronic control system with the simplicity of direct mechanically controlled unit fuel injection pressure. These features allow the C18 to completely control injection timing, duration and pressure.

Electronic Control Module. The ECM responds to operator commands and engine sensor input to optimize engine and machine performance. This advanced engine management software controls and protects the engine at all times against cold starts, high altitude operations and air filter plugging by monitoring:

- injection timing and pressure
- engine cooling fan speed
- ether starting aid
- hydraulic pumps

ADEM A4 Control Module. Controls engine rpm by adjusting the fuel duration, which results in quicker starts in hot and cold weather, better fuel economy, better operator response, and automatic compensation for altitude and filter plugging.

Reduced Exhaust Smoke. The ADEM A4 controller monitors electronic sensors to determine the optimum fuel/air ratio. Fuel is precisely controlled during cranking, starting and acceleration to reduce smoke. The Engine Electronics are faster and more efficient than mechanically controlling the governor rack position.

Ether Starting Aid. The ADEM A4 controller activates the ether injection system during engine cranking to enhance cold weather starting.

Control Throttle Shifting (CTS). Automatically synchronizes engine speed to transmission speed during shifting to reduce power train stress and increase component life. In addition it results in a smoother ride for the operator.

Directional Shift Management. Regulates engine speed to prevent damage caused by high-speed directional changes.

Low Battery Elevated Idle. The ADEM A4 controller automatically compensates for low alternator output at low idle by raising the rpm for brief intervals to keep the batteries fully charged.

Altitude Compensation. The system de-rates fuel delivery as a function of barometric pressure as sensed by the system's atmospheric pressure sensor. No manual adjustment is required. Auto deration prevents excessive combustion temperatures that could result in component damage.

Diagnostic Capability. Cat® Electronic Technician (Cat ET) is used to display real-time pressures, temperatures, fuel settings and diagnostic messages as well as a historical information such as engine over-speeds, overheating, low oil pressure and air filter restriction events.

Fuel Economy. Electronic controls optimize the timing setting for varying load conditions. The ADEM A4 controller matches timing to the load on the engine, engine rpm and temperature.

Air Filter Restriction. ADEM A4 controller monitors air filter restriction and sends a warning message to the Electronic Monitoring System (EMS III) to alert the operator if the restriction exceeds the allowable limit.

Scrapper Electrical Harness. A ribbon wiring harness replaced the cable harness for improved wear and durability. Its greater flexibility oscillates better with machine movement, and polyurethane boots offer better protection against the elements.

Automatic Belt Tensioning. Both the tractor and scraper engines have automatic belt tensioning rather than manual tensioning. The number of belts has been reduced to two on the tractor, and two on the scraper. Fan drive bearings on both the tractor and scraper engines with ACERT® technology eliminate servicing requirements.

One-Piece Power Block. The jumpstart receptacle and disconnect switch are integrated into one-piece power block that provides better electrical integrity and serviceability. The disconnect switch with lockable cover locks out all power for servicing.

NGMR Engine Cooling System. The standard radiator for the tractor is the Next Generation Modular Radiator (NGMR), which features 9 fins per inch rather than 33 fins per inch found on previous models. The increased radiator fin spacing for both the tractor and the scraper reduces clogging in severe applications. Two-piece service doors improve access to clean out debris.

Scrapper Radiator. The scraper has a brazed aluminum core scraper radiator with composite tanks featuring 9 fins per inch.

Extended Oil Change Interval. Oil change intervals in both the C18 and C9 engines can be extended to 500 hours with the use of S•O•SSM analysis.

Power Train – Transmission

Integrated electronics allow the machine to monitor the entire power train, reducing component stress and providing a better ride.



Transmission. Electronically controlled Caterpillar planetary powershift transmission with eight forward and one reverse speed. Tractor gears 1 and 2 operate in converter drive for increased torque capability during cut and fill operations. Gears 3-8 operate in direct-drive for drive train efficiency during the haul. All scraper gears operate in converter drive for increased torque capability during the cut and fill.

Synchronized Scraper Transmission. The scraper transmission is electronically controlled by the tractor transmission, synchronizing the scraper transmission gear selection with that of the tractor transmission. The scraper transmission cannot be shifted manually. A neutral/run switch, located in the cab, allows the operator to disengage the scraper transmission.

Planetary Design. Provides larger contact area between gears than countershaft transmissions for greater load-carrying capacity.

Transmission Hold. Incorporated into the joystick controller, Transmission Hold allows the operator to maintain converter drive for increased rimpull, or hold the current gear for enhanced control.

Programmable Top Gear Selection. Allows the operator to manually set the top gear (3rd–8th) available to match conditions or to match the hauling speed of the fleet to specific job-site needs.

Retarder. The hydraulic retarder can be used to slow the ground speed of the machine when entering the cut or fill area to allow the transmission to downshift. It also reduces service brake wear and enhances machine control.

Differential Control. Electronic differential lock helps prevent the drive wheels from spinning in poor underfoot conditions. The operator engages the differential lock with a foot control located in the cab.

Neutral Coast Inhibitor. Prevents the transmission from shifting into neutral if the operator selects neutral while moving. The transmission control will select the proper gear for the given engine rpm and ground speed.

Final Drives. Outboard-mounted, planetary design final drives reduce torque loads on other power train components. Large-capacity, double-row roller bearings and Caterpillar Duo-Cone® seals deliver exceptional reliability in the toughest applications.

Independent Brake Systems. Expanding-shoe type brakes use a cam-operated design, which is air-applied and spring released. The secondary braking system uses independent front and rear circuits that are automatically applied if the service air pressure drops to 380 kPa (55 psi). Audible and visual action alert indicators inform the operator when the service air pressure drops to 518 kPa (75 psi).

Parking Brakes. The push-button operated parking brake features a spring-applied, air-released mechanism that operates the service brakes.

Steering. Full hydraulic power steering provides automotive feel with positive, modulated flow control for constant steering response. An optional secondary steering system is ground-driven and provides hydraulic power for steering if needed.

Structures

Superior structural design and construction optimize performance and reliability.

Cushion Hitch. The electronically actuated cushion hitch incorporates a parallelogram-type linkage for exceptional strength. Twin nitrogen accumulators help deliver a smooth ride for enhanced operator comfort.

- cushion hitch lock down control for positive cutting edge down pressure when loading or spreading
- controlled oil flow dampens rebound oscillation
- leveling valve automatically centers piston in cylinder for all loads
- steel castings are used extensively to eliminate many welded joints and increase strength
- double-kingbolt design withstands high external forces and simplifies installation and removal



- 1 Load cylinder
- 2 Hitch castings
- 3 Scraper gooseneck
- 4 Nitrogen accumulators
- 5 Orifice
- 6 Oil from tractor hydraulic system
- 7 Leveling valve
- 8 Free floating pistons

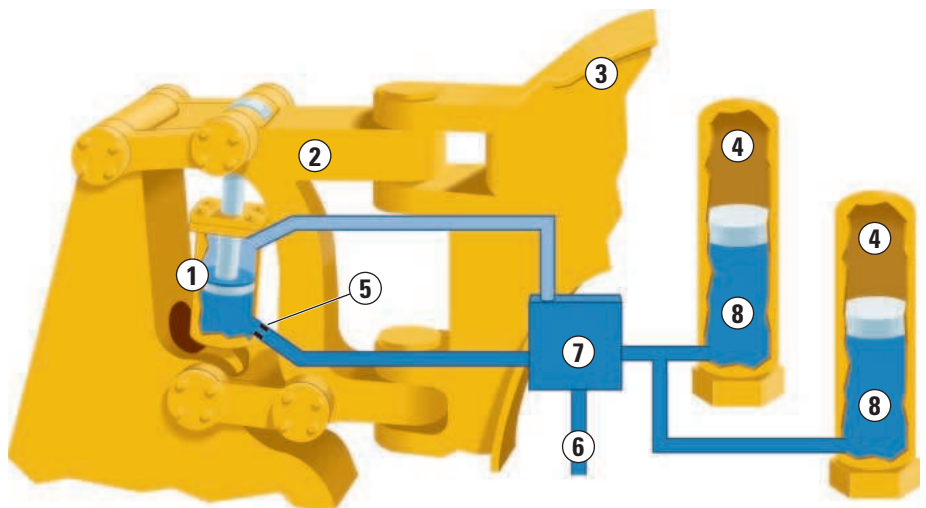

Nitrogen Accumulators. Vertically mounted hydraulic cylinder transfers road shocks to nitrogen accumulators. They absorb and dampen road shocks, thus reducing loads from being transmitted to the operator.

Lockout Switch. An operator-selectable lockout switch, located on the joystick, locks the cushion hitch for improved control of the cutting edge during loading and dumping.

Operator Station

State-of-the-art productivity and operator comfort.



Seat Suspension. The new standard seat suspension features a high performance air shock absorber with a self-contained air compressor. For operators requiring additional damping, dual shock absorbers in the seat suspension are available.

Revised Steering Column. Increases legroom a full 89 mm (3.5 in.), and reduces knee contact.

Standard Air Conditioning. Standard air conditioning system with relocated louvers enhances airflow in the cab.

Storage And Amenities. Convenient storage location includes space for a lunch box and first aid kit. The cab also has a cup holder as well as an ashtray.

Visibility. The redesigned hood has sloped corners to maximize visibility while accommodating the low emissions engine.

The redesigned hood and front shroud are wider to enclose the air-to-air aftercooler (ATAAC), ether starting aid, and lights. The exhaust is located at the back of the hood for good visibility to the right side.

Instrument Display Panel. Features a new quad-gauge layout showing engine coolant temp, transmission/torque converter oil temp, fuel level, and system air pressure. The 637G tachometer can monitor either front or rear engine speeds. Once the 637G tractor engine has been started, the operator can start the rear engine from inside the cab using a switch on the instrument panel. EMS III can display both front and rear engine information right in the cab.

Logical Control Placement. Placing only frequently used switches and indicator lights on the instrument panel, and less frequently used switches on the overhead console, improves efficiency and reduces reaching.

Multi-Adjustable Seat. The Cat Comfort Cloth Seat offers an adjustable seat and armrests for maximum operator comfort.

- Swivels and locks in four positions (0°–10° – 20°–30°) providing the optimum operating position in the cut or on the haul.
- Adjustable 102 mm (4 in.) fore/aft and 203 mm (8 in.) vertical height to accommodate various sized operators.
- Static seat belt is standard. A retractable non-cinching seat belt is available as an option.



Engine Speed Lock Controller.

Enhances operation during long haul cycles by allowing the operator to maintain a desired engine speed without maintaining pressure on the throttle.



Simplified Transmission Control.

Simplifies gear selection (1st, 2nd, Drive and Reverse) and allows operator-defined top gear control. Relocating the gear control to the rear increases operator legroom.

Neutral Lock . The neutral lock thumb control must be pressed to move the shifter from neutral. To use the top gear button, the operator must hold the yellow button until the gear display indicates the desired top gear. Releasing the yellow button sets the top gear.

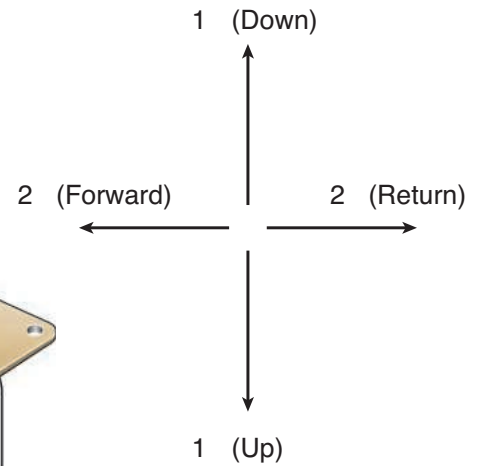
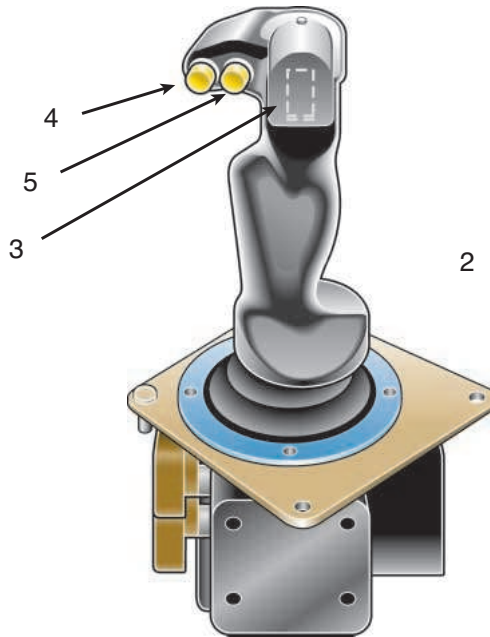

Joystick Control: positions, switches and buttons

Grab Handle/Hand Rest. The grab handle/hand rest located next to the joystick controller helps operators when adjusting seat swivel, and gives them a place to rest their hand while on the haul and return roads.

Single Lever Implement Control. Simple and easy to operate, the joystick enhances the productivity of operators of all skill levels. Requires less force to control the critical scraper functions and requires less lever travel.

- 1) Bowl (forward and back)
 - 2) Ejector (side to side)
 - 3) Apron (thumb rocker switch)
 - 4) Transmission Hold
 - 5) Cushion Hitch
 - 6) Rocker switch (not shown – is on front of joystick)
- Auger (on/off)
 - Push-Pull (bail up/down)
- * Standard open bowl does not have a rocker switch.

Electronic Controls

Integrated electronic controls provide smooth, consistent shifts through the synchronization of engine and transmission speeds.



Simplified System. The electrical system has been redesigned to utilize three electronic control modules (ECM) on the tractor instead of four. The rear-powered scraper now has two ECMs rather than three.

Air Filter Restrictor Indicator.

The ADEM A4 controller monitors air filter restriction. If the restriction exceeds the allowable limit, it alerts the operator by sending a message to the Electronic Monitoring System (EMS III).

Automatic Ether Injection. The ADEM A4 controller activates the ether injection system during engine cranking to enhance cold weather starting.

Automatic Altitude Compensation.

At high altitudes the system automatically de-rates fuel delivery as a function of barometric pressure sensed by the system's atmospheric pressure sensor.

Low Battery Elevated Idle. The ADEM A4 controller automatically compensates for low alternator output at low idle by raising the rpm for brief intervals to keep the batteries fully charged.

Improved Serviceability. Combined monitoring systems, easy access diagnostics and more durable components make routine maintenance and servicing simple and fast.

Combined EMS Monitoring.

The Electronic Monitoring System (EMS III) is designed to monitor both the tractor and scraper from one location instead of two. Both the tractor and powered scraper use the same controller for parts commonality and easier servicing.

Easy Access Diagnostics. A variety of diagnostic codes are accessible through the EMS main display module, via the Electronic Technician (Cat ET). This offers a head start on problem solving, so with a radio call the service technician can know which tools, troubleshooting guides, and possibly even replacement parts to bring to the machine.

Greater Reliability. The EUI system has fewer moving parts than mechanical unit injection and requires few adjustments. The ADEM A4 controller communicates with the monitoring system (EMS) to warn the operator when problems arise, to help avoid major damage.

Maintenance. EUI engines have virtually no mechanically controlled parts to wear or adjust. These have been replaced by electronic controls, reducing maintenance costs and increasing machine availability.

Product Link. Product Link is a wireless system that allows the customer to track machine data such as location, service meter hours as well as machine health information. The system can automatically issue alerts when the machine is operated beyond owner-defined time and location limits.

Product Link is available as a factory attachment or it may be installed in the field in that there is a mounting location for the module as well as an antenna on the machine. A wiring breakout is standard, eliminating the need to splice into existing wires.

Fuel Economy. Electronic controls optimize the timing setting for varying conditions. The ADEM A4 controller matches timing to the load on the engine, engine rpm and temperature.

Reduced Exhaust Smoke. The ADEM A4 controller monitors electronic sensors to determine the optimum fuel/air ratio. Fuel is precisely controlled during cranking, starting and acceleration to reduce smoke. The Engine Electronics are faster and more efficient than mechanically controlling the governor rack position.

Scraper Bowl

Designed for optimum loading, material retention and ejection.

Redesigned Bowl. The redesigned bowl minimizes falling material lodging between the bowl and the draft arm, which can result in premature wear. The modifications also provide better load retention on level ground or traversing down a grade. Bowl capacity has been increased by 3 yd³ (2.3 m³), allowing more material to be moved.

- Low-profile bowl design offers less resistance to incoming materials.
- Cellular construction adds strength and dent resistance to bowl sides and floor.

Bulldozer Ejection System. Cat bulldozer ejection system offers constant spreading control with minimal material carry back. A spill guard helps retain material and keep it from spilling over onto the rear of the scraper (standard on tandem engine scrapers, optional on single engine open bowl scrapers).

Cutting Edges. May be adjusted according to job conditions. The stinger (drop down) position provides good penetration and efficient flow of material into the bowl, whereas the level cutting edge is used for finish work or very high impact conditions.

Ground Engaging Tools. A wide variety of Cat Ground Engaging Tools (GET) options such as standard, serrated, and abrasion resistant material (ARM), are available to optimize scraper loading in various materials. For example, ARM scraper cutting edges and router bits will provide up to five times the wear life of conventional edges and router bits in high wear, low impact applications. Depending on applications, the serrated cutting edge may be more cost effective than the integrated tooth cutting edge.



Tandem Engine. Two engines ensure the power to handle steep grades, and makes possible all wheel drive to handle soft, slippery underfoot conditions.

Dual Horsepower. On the tandem engine scraper, the rear engine has dual horsepower capability that results in better performance on the haul roads.

Material Application. Well suited to handle a wide variety of material from clay to shot rock.

Push-Loading. To achieve maximum productivity, the 631G should be push loaded by a D9R or D10R Track-Type Tractor. The larger tractor offer quicker loading times with denser loads than the smaller tractor.

Push-Pull Arrangement (637G only)

Caterpillar offers a self-loading arrangement for the 637G.



Typical push-pull operation using twin 627G machines.

Push-Pull Attachment . This optional arrangement concentrates the combined horsepower of two machines onto one cutting edge. The push-pull attachment allows two individual machines to act as a self-loading system, typically loading both machines in less than a minute.

Flexible Fleet. This system provides a more balanced, flexible fleet using fewer machines and less investment than comparable self-loading or push-loading systems.

Hydraulically Actuated Bail. The push-pull arrangement uses a hydraulically actuated bail and cushioned plate bolted to the front of the tractor, and a hook that is attached to the rear of the scraper. There is an actuator indicator light on the dash that will turn on when the trigger is engaged to actuate the push-pull bail or auger.

Auger Arrangement

Excellent self-loading capability in a wide range of material.

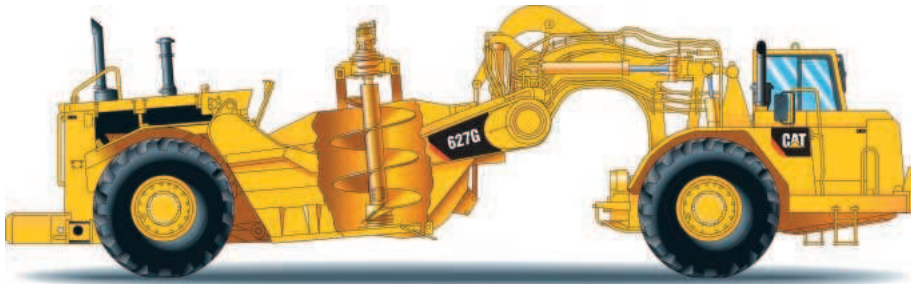

Versatility. The auger has a wide material appetite ranging from rock to free flowing material such as sand.

Auger Mechanism. The auger lifts material off of the cutting edge, conditions it and carries it to the top of the load for true self-loading capability. Material is distributed evenly throughout the bowl, resulting in consistent loads.

Material Handling. The auger actions on the material produce several benefits:

- wide material appetite, ideal for landfills
- blends the material to help eliminate voids in the bowl for consistent payloads
- conditions material for precise metering and better compaction in the fill
- reduces dust and noise during loading

Dual Horsepower. Tractor engine automatically reverts to the higher setting when the auger motor is engaged.

Slip Limiter Switch. Prevents rear wheel spin during loading.

Hydraulic System. Single hydraulic system for entire machine with separate implement pumps/valves simplifies maintenance and improves reliability.

Implement Valve Relocation.

The implement valve has been relocated from the tractor to the top of scraper draft tube. The result is fewer hoses and tubes that cross over the gooseneck, and fewer potential leak points. The relocation also improved access to the implement valve for better serviceability.



Electro-hydraulic Controls. The 627G features full electro-hydraulic controls, which simplify serviceability and reduce noise by replacing the cab pilot valves with a single-lever joystick control. The high efficiency oil filter provides cleaner oil for the pilot system.

Full-flow Circuits. The hydraulic system features closed-loop, full-flow hydraulic circuits powered by gear-type and piston-type pumps.

Apron. Prevents material spillage and retains fine material far better than an elevating scraper.

Serviceability

Count on Caterpillar for simplified service and the most productive uptime.



Grouped Service Points. Maintenance and service points for the engine are grouped on the right-hand side for easy access. They include the engine air cleaner, engine oil check and fill, fuel filters and priming, coolant level sight glass, window washer bottle, air conditioning dryer cartridge, ether starting aid canister, engine oil filter, fan drive lubrication, and sampling ports for the engine oil and coolant.

- Spin-on fluid filters for all but the main hydraulic filter
- Cab wiring harness redesigned and relocated for better serviceability

Two-Piece Service Doors. The tractor has a standard two-piece door on the right side, which allows better access to service points. The hood is hinged on the front and has spring struts, so the hood easily swings open towards the front of the machine. This allows better access to those areas located on top of the engine.

Electronic Monitoring System (EMS III).

Monitors both the tractor and scraper from one location instead of two. Both the tractor and powered scraper use the same controller for parts commonality and easier servicing.

Electro-Hydraulic Implement Control.

Simplifies serviceability by removing the cab pilot valve and associated lines, which also improves reliability and reduces noise. The high efficiency oil filter provides cleaner oil for the pilot system.

Electronic Technician. The Caterpillar Electronic Technician (Cat ET) Service Tool is useful in troubleshooting existing problems or identifying potential problems by displaying:

- Real-time pressures, temperatures, fuel settings and diagnostic messages
- Historical data such as engine over-speeds, overheating, low oil pressure and air filter restriction events
- More detailed information to the service technician who can access Cat ET via a laptop computer

Easy Access Diagnostics. A variety of diagnostic codes are accessible through the EMS main display module, via the Electronic Technician (Cat ET). This offers a head start on problem solving, so with a radio call the service technician can know which tools, troubleshooting guides, and possibly even replacement parts to bring to the machine.

SAFETY.CAT.COM™.

Customer Support

Cat dealer services help you operate longer with lower costs.



Product Support. You will find nearly all parts at our dealer parts counter. Cat dealers use a world-wide computer network to find in-stock parts to minimize machine down time. To save money use genuine Cat Reman parts whenever possible. You receive the same warranty and reliability as new products at substantial cost savings.

Machine Selection. Make detailed comparisons of the machines under consideration before purchase. Cat dealers can estimate component life, preventive maintenance cost, and the true cost of lost production.

Purchase. Look past initial price. Consider the financing options available as well as day-to-day operating costs. Look at dealer services that can be included in the cost of the machine to yield lower equipment owning and operating costs over the long run.

Customer Support Agreements. Cat dealers offer a variety of product support agreements, and work with customers to develop a plan that best meets specific needs. These plans can cover the entire machine, including attachments, to help protect your investment.

Operation. Improving operating techniques can boost your profits. Your Cat dealer has videotapes, literature and other ideas to help you increase productivity, and Caterpillar offers certified operator training classes to help maximize the return on your machine investment.

Maintenance Services. Talk to your dealer about the range of available maintenance services. Repair option programs guarantee the cost of repairs up front. Diagnostic programs such as S•O•SSM Analysis and Coolant Sampling and Technical Analysis help avoid unscheduled repairs.

Replacement. Repair, rebuild or replace? Your Cat dealer can help you evaluate the cost involved so you can make the right choice.

Engine

Tractor Engine	Cat C18 ACERT™
Scraper Engine	Cat C9 ACERT

Tractor Engine

Net Power	345/373 kW	462/500 hp
Gross Power – Gears 1-2	364 kW	488 hp
Gross Power – Gears 3-8	392 kW	526 hp
Net Power – Gears 1-2	345 kW	462 hp
Net Power – Gears 3-8	373 kW	500 hp
Bore	145 mm	5.7 in
Stroke	183 mm	7.2 in
Displacement	18.1 L	1,105 in ³

- Net power advertised is the power available at rated speed of 1,800 rpm, measured at flywheel when the engine is equipped with fan, air cleaner, muffler and alternator.
- Net power ratings apply at 1,800 rpm when tested under the specified standard conditions for ISO 9249 and EEC 80/1269.

Scraper Engine

Net Power	198/211 kW	266/283 hp
Gross Power – Gear 1	213 kW	286 hp
Gross Power – Gears 2-4	226 kW	303 hp
Net Power – Gear 1	198 kW	266 hp
Net Power – Gears 2-4	211 kW	283 hp
Bore	112 mm	4.4 in
Stroke	149 mm	5.9 in
Displacement	8.8 L	538 in ³

- Net power advertised is the power available at rated speed of 2,000 rpm, measured at flywheel when the engine is equipped with fan, air cleaner, muffler and alternator.
- Net power ratings apply at 1,800 rpm when tested under the specified standard conditions for ISO 9249 and EEC 80/1269.

Scraper Bowl

Heaped Capacity	26 m ³	34 yd ³
Rated Load	37 285 kg	82,200 lb
Struck Capacity	18.3 m ³	24 yd ³
Depth of Cut – max.	437 mm	17.2 in
Width of Cut, to Router Bits	3512 mm	138.3 in
Ground Clearance – max.	545 mm	21.5 in
Cutting Edge – thickness	28 mm	1.12 in.
Hyd. Penetration Force – 631G	255 kN	57,375 lb
Hyd. Penetration Force – 637G	360 kN	81,000 lb
Depth of Spread – max.	480 mm	18.9 in
Apron Opening	2007 mm	79 in
Apron Closure Force	170 kN	38,250 lb

Hydraulics

Bowl Cylinder Bore	184 mm	7.2 in
Bowl Cylinder Stroke	873 mm	34.4 in
Apron Cylinder Bore	210 mm	8.2 in
Apron Cylinder Stroke	727 mm	28.6 in
Ejector Cylinder Bore	210 mm	8.2 in
Ejector Cylinder Stroke	1880 mm	74 in
Steering Circuit	379 L/min	100 gal/min
Scraper Circuit	344 L/min	91 gal/min
Cushion Hitch Circuit	34.5 L/min	9 gal/min
Secondary Steering Circuit	379 L/min	100 gal/min
Relief Valve – Steering Circuit	13 700 kPa	1,987 psi
Relief Valve – Implement Circuit	14 000 kPa	2,030 psi
Compensator Setting – Cushion Hitch Circuit	16 000 kPa	2,320 psi

Steering

Width – 180° Turn	12.2 m	40 ft 1 in
Steering Angle – right	90°	
Steering Angle – left	85°	

- Optional secondary steering system meets SAE J1511 (OCT 90) and ISO 5010 (1992) requirements.

Service Refill Capacities – Tractor

Crankcase	45 L	11.9 gal
Transmission	110 L	29 gal
Differential	148 L	39 gal
Final Drive (per side)	23 L	6.1 gal
Cooling System	110 L	29 gal
Hydraulic Reservoir	190 L	50.2 gal
Wheel Coolant (each)	75 L	19.8 gal
Windshield Washer	6 L	1.5 gal

Service Refill Capacities – Scraper

Fuel Tank – 631G	814 L	215 gal
Fuel Tank – 637G	1268 L	335 gal
Crankcase	30 L	7.9 gal
Transmission	72 L	19 gal
Differential	12 L	3.2 gal
Final Drive (per side)	19 L	5 gal
Wheel Coolant (each)	75 L	19.8 gal
Cooling System	76 L	20 gal

Standards

- Standard Rollover Protective Structure (ROPS) which meets SAE J320a, SAE J1040 MAY 94, ISO 3471-1986 and ISO 3471-1994
- Falling Object Protective Structure (FOPS) which meets SAE J231 JAN 81 and ISO 3449-1992
- The operator sound pressure level measured according to the procedures specified in ISO 6394:1998 is 85 dB(A) for the cab offered by Caterpillar, when properly installed and maintained and tested with the doors and windows closed.
- Standard air conditioning system contains environmentally friendly R134a refrigerant.
- Brakes meet ISO 3450: 1998

Dimensions

All dimensions are approximate.

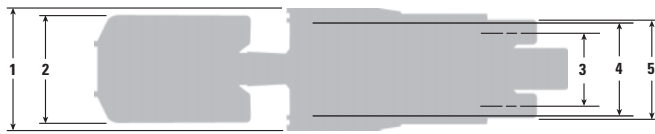

631G

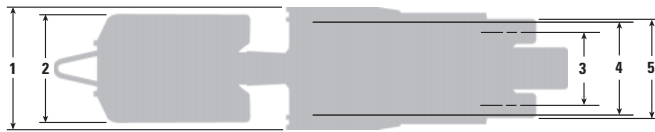
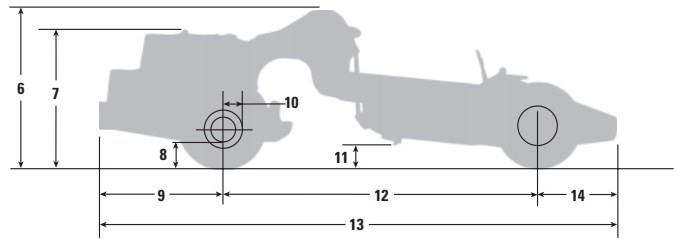

637G

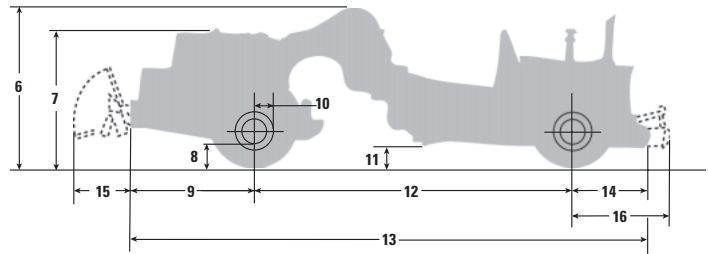

1	Width – overall machine	3938 mm	155 in
2	Width – tractor	3481 mm	137 in
3	Width – rear tire center lines	2464 mm	97 in
4	Width – inside of bowl	3405 mm	134 in
5	Width – outside rear tires	3636 mm	143.2 in
6	Height – overall shipping	4286 mm	168.8 in
7	Height – top of cab	3715 mm	146.3 in
8	Ground Clearance, Tractor	665 mm	26.2 in
9	Front of Tractor to Front Axle	3359 mm	132.2 in

10	Axle to Vertical Hitch Pin	548 mm	21.6 in
11	Height – scraper blade max.	545 mm	21.5 in
12	Wheelbase	8769 mm	345.2 in
13	Length – overall machine	14 565 mm	573.4 in
14	Rear Axle to Rear of Machine	2437 mm	96 in
15	Bail Length – max. (push-pull)	4960 mm	195.3 in
16	Extended Push Block (push-pull)	2744 mm	108 in

Weights

(approximate)

Model	631G		637G		637G	
			Standard		Push-Pull	
Shipping, with ROPS cab and 10% fuel						
Front axle	67%		59%		59%	
	30 393 kg	67,005 lb	30 177 kg	66,529 lb	31 071 kg	68,499 lb
Rear axle	33%		41%		41%	
	14 969 kg	33,001 lb	20 970 kg	46,231 lb	21 591 kg	47,601 lb
Total 100%	45 362 kg	100,006 lb	51 147 kg	112,760 lb	52 662 kg	116,100 lb
Operating empty, with ROPS cab, full fuel tanks and operator						
Front axle	67%		59%		59%	
	31 138 kg	68,648 lb	30 708 kg	67,700 lb	31 602 kg	69,670 lb
Rear axle	33%		41%		41%	
	15 337 kg	33,812 lb	21 339 kg	47,044 lb	21 960 kg	48,414 lb
Total 100%	46 475 kg	102,460 lb	52 047 kg	114,744 lb	53 562 kg	118,084 lb
Loaded, based on a rated load of 37 285 kg (82,200 lb)						
Front axle	53%		49%		49%	
	44 393 kg	97,870 lb	43 773 kg	96,503 lb	44 515 kg	98,139 lb
Rear axle	47%		51%		51%	
	39 367 kg	86,790 lb	45 559 kg	100,441 lb	46 332 kg	102,145 lb
Total 100%	83 760 kg	184,660 lb	89 332 kg	196,944 lb	90 874 kg	200,284 lb

Transmission

Model	631G		637G	
	Forward	1	4.7 kph 2.9 mph	5.5 kph 3.4 mph
	2	8.4 kph 5.2 mph	10.0 kph 6.2 mph	
	3	11.9 kph 7.4 mph	12.2 kph 7.6 mph	
	4	16.1 kph 10.0 mph	16.6 kph 10.3 mph	
	5	21.6 kph 13.4 mph	22.2 kph 13.8 mph	
	6	29.3 kph 18.2 mph	30.1 kph 18.7 mph	
	7	39.4 kph 24.5 mph	40.6 kph 25.2 mph	
	8	53.5 kph 33.2 mph	54.9 kph 34.1 mph	
Reverse		9.9 kph 6.2 mph	9.9 kph 6.2 mph	

Gradeability/Speed/Rimpull

To determine gradeability performance: Read from gross weight down to the percent of total resistance. Total resistance equals actual percent grade plus 1% for each 9 kg/t (20 lb/ton) of rolling resistance. From this weight-resistance point, read horizontally to the curve with the highest obtainable gear, then down to maximum speed. Usable rimpull will depend upon traction available and weight on drive wheels.

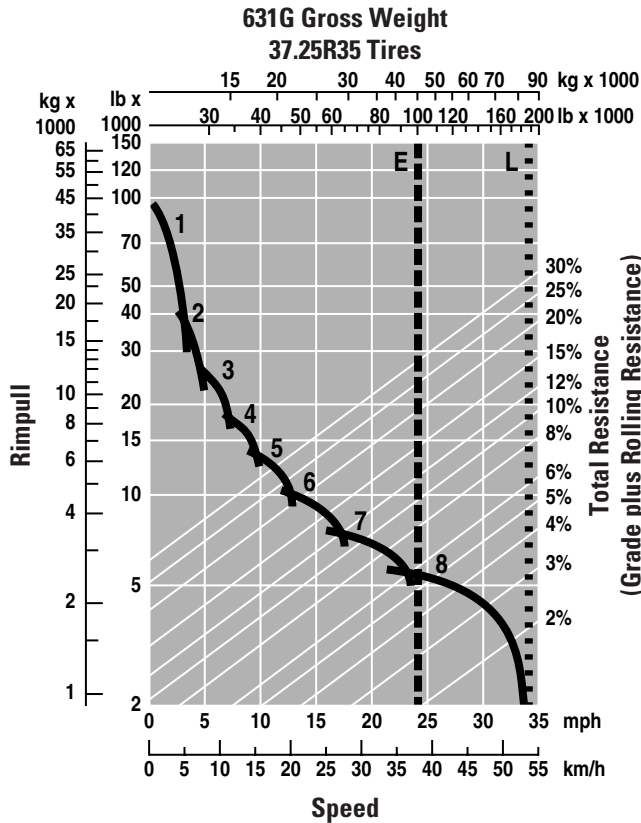

- 1—1st Gear Torque Converter Drive
- 2—2nd Gear Torque Converter Drive
- 3—3rd Gear Direct Drive
- 4—4th Gear Direct Drive
- 5—5th Gear Direct Drive
- 6—6th Gear Direct Drive
- 7—7th Gear Direct Drive
- 8—8th Gear Direct Drive
- E—Empty 46 475 kg (102,460 lb)
- L—Loaded 83 760 kg (184,660 lb)

Retarding

To determine retarding performance: Read from gross weight down to the percent effective grade. (Effective grade equals actual percent grade minus 1% for each 9 kg/t (20 lb/ton) of rolling resistance). From this weight-effective grade point, read horizontally to the curve with the highest obtainable speed range, then down to maximum descent speed the retarder can properly handle.

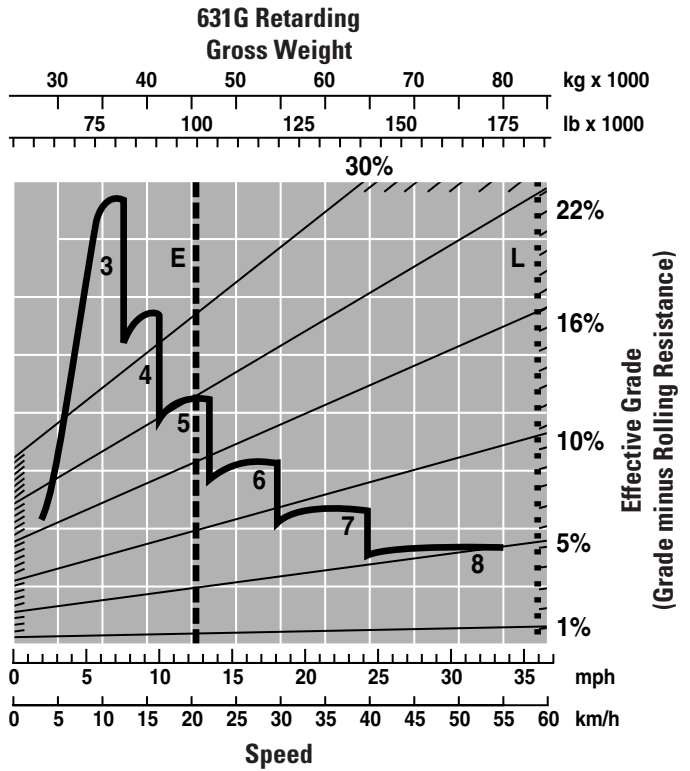

- 3—3rd Gear Direct Drive
- 4—4th Gear Direct Drive
- 5—5th Gear Direct Drive
- 6—6th Gear Direct Drive
- 7—7th Gear Direct Drive
- 8—8th Gear Direct Drive
- E—Empty 46 475 kg (102,460 lb)
- L—Loaded 83 760 kg (184,660 lb)

Gradeability/Speed/Rimpull

To determine gradeability performance: Read from gross weight down to the percent of total resistance. Total resistance equals actual percent grade plus 1% for each 9 kg/t (20 lb/ton) of rolling resistance. From this weight-resistance point, read horizontally to the curve with the highest obtainable gear, then down to maximum speed. Usable rimpull will depend upon traction available and weight on drive wheels.

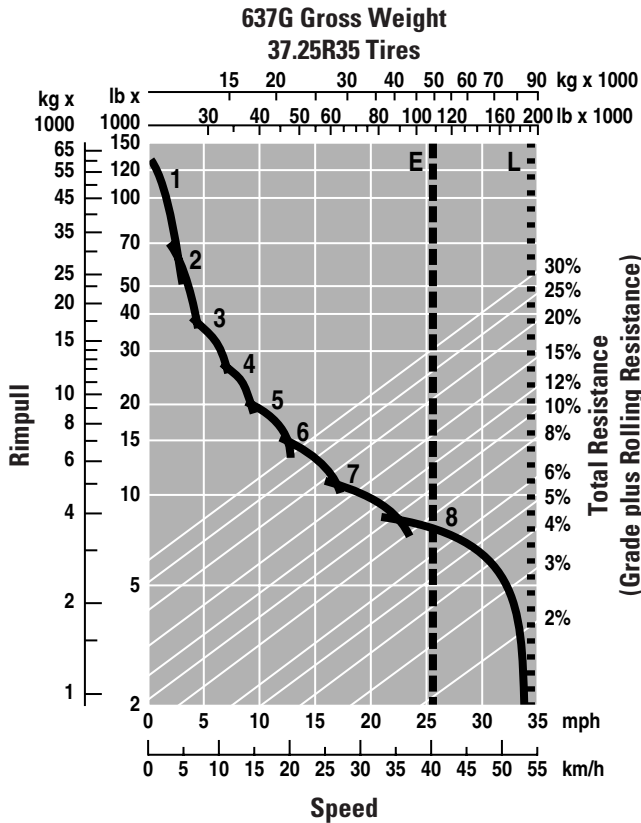

- 1—1st Gear Torque Converter Drive
- 2—2nd Gear Torque Converter Drive
- 3—3rd Gear Direct Drive
- 4—4th Gear Direct Drive
- 5—5th Gear Direct Drive
- 6—6th Gear Direct Drive
- 7—7th Gear Direct Drive
- 8—8th Gear Direct Drive
- E—Empty 52 047 kg (114,745 lb)
- L—Loaded 89 332 kg (196,944 lb)

Retarding

To determine retarding performance: Read from gross weight down to the percent effective grade. (Effective grade equals actual percent grade minus 1% for each 9 kg/t (20 lb/ton) of rolling resistance). From this weight-effective grade point, read horizontally to the curve with the highest obtainable speed range, then down to maximum descent speed the retarder can properly handle.

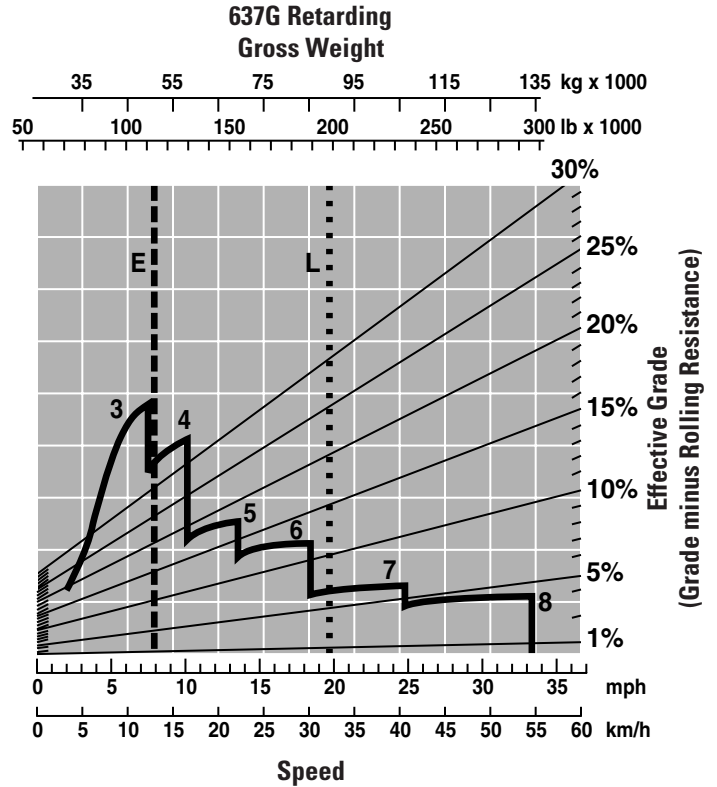

- 3—3rd Gear Direct Drive
- 4—4th Gear Direct Drive
- 5—5th Gear Direct Drive
- 6—6th Gear Direct Drive
- 7—7th Gear Direct Drive
- 8—8th Gear Direct Drive
- E—Empty 52 047 kg (114,745 lb)
- L—Loaded 89 332 kg (196,944 lb)

Standard Equipment

Standard equipment may vary. Consult your Caterpillar dealer for details.

ELECTRICAL

- Alarm, backup
- Alternator, 75 amp – tractor engine
- Alternator, 35 amp – scraper engine (637G)
- Batteries (4), 12V Maintenance Free, High Output
- Batteries (2), 12V Maintenance Free, High Output (637G)
- Electrical System, 24V
- Lighting System – Tractor
 - Directional Signals; Hazard Lights; Headlights, halogen with dimmer; Floodlight, Cutting edge
- Lighting System – Scraper
 - Directional Signals; Hazard Lights; Stop/Tail
- Starting Receptacle – tractor and scraper engines

OPERATOR ENVIRONMENT

- Air Conditioner (includes heater and defroster)
- Cigarette Lighter and Ashtray
- Coat Hook
- Diagnostic Connection Port (12V)
- Dome Courtesy Light
- Gauge Group
 - Air Pressure
 - Converter/Retarder temperature
 - Electronic Monitoring System (EMS III)
 - Engine coolant temperature
 - Actual Transmission Gear Indicator
 - Fuel
 - Speedometer
 - Tachometer
 - Transmission gear indicator
- Horn
- Implement Control Joystick
- Rearview Mirrors
- Radio Ready (two radio openings, speakers, and 5-amp converter)
- ROPS Cab with Sound Suppression and Pressurization
- Static Seatbelt
- Scraper Engine Controls (637G)
- Seat, Air Suspension, Caterpillar Comfort, cloth
- Steering Wheel – tilt and telescoping
- Storage Compartment
- Throttle Lock
- Transmission Hold
- Windows – sliding side, swing out
- Windshield – laminated glass
- Windshield Wiper/Washer – front and rear

POWER TRAIN

- Engine
 - Electric start, 24V
 - Fan, suction (steel spider with nylon blades)
 - Ground level engine shutdown
 - Muffler
 - Starting Aid, ether
 - Thermo-shield, exhaust manifold and turbo soft wrapped
- Tractor:
 - Cat C18 with ACERT™ Technology
 - 6 cylinder diesel, Mechanical Electronic Unit Injection (MEUI)
 - Air Cleaner, dry-type with pre-cleaner
 - Guard, crankcase
 - Radiator, NGMR (9 fins per inch)
- Scraper (637G):
 - Cat C9 with ACERT Technology
 - 6 cylinder diesel, Mechanical Electronic Unit Injection (MEUI)
 - Radiator, brazed aluminum core, composite tanks (9 fins per inch)
- Braking System
 - Parking/Primary/Secondary
 - Shields – brake
- Transmission
 - Tractor:
 - 8-speed automatic Powershift with Electronic Control
 - Control throttle shifting
 - Differential – lockup
 - Downshift Inhibitor
 - Neutral coast inhibitor
 - Programmable top-gear selection
 - Scraper (637G):
 - 4-speed automatic Powershift with Electronic Control

OTHER STANDARD EQUIPMENT

- Extended Life Coolant, -36° C (-33° F)
- Fan hub, permanent lube
- Fast Oil Change
- Fenders
- Rims – 35 inch (2)
- Tires, 37.50-R35 radial
- Tractor:
 - Air dryer
 - Cushion hitch
 - Locks, vandalism (oil fill, dipstick)
 - Product Link ready
 - Tow Pins – front and rear
- Scraper:
 - Air inlet heater
 - Fuel System – (637G, fast fill European Union Compliant)

Optional Equipment

Optional equipment may vary. Consult your Caterpillar dealer for details.

Auger

Crankcase Guard, Heavy Duty

Extended Life Coolant, -50° C (-58° F)

Fan, Defrost

Fenders (631G scraper)

Fuel system – (631G, fast-fill European Union Compliant)

Heater – jacket water (all engines)

Hydraulic Retarder

Lights, Side Vision

Lock, Steering

Overflow Scraper Guard (631G)

Power train Guard

Push Block – extended (637G scraper)

Push-Pull Arrangement w/Rear Radiator Guard (637G)

Retractable seat belts

Secondary Steering

631G/637G Wheel Tractor Scrapers

For more complete information on Cat products, dealer services,
and industry solutions, visit us on the web at www.cat.com

© 2007 Caterpillar
All Rights Reserved
Printed in U.S.A.

Materials and specifications are subject to change without notice.
Featured machines in photos may include additional equipment.
See your Caterpillar dealer for available options.

AEHQ5651-01 (10-07)

Replaces AEHQ5651 (11-05)

CAT, CATERPILLAR, ACERT, ADEM, SAFETY.CAT.COM, their respective logos,
"Caterpillar Yellow" and the POWER EDGE trade dress, as well as corporate and product
identity used herein, are trademarks of Caterpillar and may not be used without permission.

CATERPILLAR[®]