

725

Articulated Truck



Engine

Engine Model	Cat [®] 3176C ATAAC EUI	
Gross Power	223.7 kW	300 hp
Flywheel Power	209 kW	280 hp

Weights

Rated Payload	23.6 tonnes	26 tons
---------------	-------------	---------

Body Capacities

Heaped SAE 2:1	14.3 m ³	18.8 yd ³
----------------	---------------------	----------------------

725 Articulated Truck

The 725 Caterpillar® Articulated Truck is a world-leading earthmoving solution.

Performance and Productivity - Power Train

High power Cat 3176C ATAAC electronic engine, electronically controlled transmission, and a new faster acting, more powerful retarder deliver the performance needed to get the job done. **pg. 4**

Performance and Productivity

Cross-axle differential locking system provides full driveline locking for maximum performance in adverse conditions. Three-point front suspension provides a smoother ride allowing the operator to travel faster over rough terrain. **pg. 5**

Operator Comfort

Larger center-mounted cab, oscillating front axle, air suspension seat and increased storage space provide exceptional operator comfort. **pg. 6**

Complete Customer Support

Your Cat dealer offers a wide range of services that can be set up under a customer support agreement when you purchase your equipment. The dealer will help you choose a plan that can cover everything from machine configuration to eventual replacement. **pg. 10**

Best in its class, the 725 offers proven reliability and durability, high performance, low fuel consumption, operator comfort and low operating costs.



Ease of Operation

Ergonomically designed wrap-around dash, tilt and telescopic steering wheel, easy to reach controls and better all around viewing promote fast, confident machine operation for top productivity. **pg. 7**

Durability and Reliability

The 725 has built-in durability and reliability. Cat purpose-built, articulated truck drivetrain components, improved front frame and hitch assure top performance in the toughest applications. **pg. 8**

Serviceability

Longer service intervals and easier maintenance result in better machine availability, lower owning and operating costs. **pg. 9**



Performance and Productivity - Power Train

Integrated Power Train — More Power, Greater Performance and Lower Fuel Consumption.



3176C Electronic Engine. The electronic version of this proven engine delivers higher power, durability and complete system integration of the engine and transmission for maximum efficiency.

High Torque Rise. Provides unequalled lugging force during acceleration, on steep grades and in tough underfoot conditions.

Turbocharged and ATAAC. Air-to-air aftercooling provides improved fuel economy by packing cooler, denser air into cylinders for more complete combustion of fuel and lower emissions.

Electronic Control Module (ECM).

Advanced Diesel Engine Management III (ADEM III) provides improved emissions, performance, advanced troubleshooting and diagnostic capabilities.

Fuel Efficiency. The electronically controlled, computer-actuated unit injection fuel system has high injection pressure for complete fuel combustion, greater fuel efficiency and reduced emissions.

Engine Construction. Caterpillar designed one-piece cast iron block provides strength and maximum durability. Two-piece articulated pistons with forged steel crowns withstand higher cylinder pressure.

Electronic Transmission. The new six-speed electronically controlled transmission is designed specifically for the articulated truck and its applications.

Controlled Throttle Shifting (CTS). CTS significantly reduces power train stress and clutch wear by controlling engine speed, torque converter lock up and transmission clutch engagements.

Electronic Clutch Pressure Control.

ECPC technology works with CTS to manage shift torque and provide exceptional shift smoothness.

Retarder. Integral retarder with a new high power density design. Due to its compact size, the unit quickly fills with oil, providing more retarding power and faster, fuller response times.

Performance and Productivity

Productivity in All Conditions — All Terrain All the Time.

Front Suspension. The three-point front suspension oscillates $\pm 6^\circ$ to provide a smoother ride allowing the 725 to travel faster over rough terrain and softening impact loads on structures and components.

Rear Suspension. The rear suspension features a mechanical walking beam geometry that extends component life and provides a stable ride for excellent load retention.

Traction Control. Inter-axle differential lock and cross-axle differential locks provide 100% driveline locking. All differentials are hydraulically actuated, oil-immersed, multi-plate clutch type that can be engaged and disengaged on-the-go for maximum versatility.

Inter-axle Differential Lock. Locks all three axles together for excellent traction in poor underfoot conditions. It is operated by a switch incorporated into the footrest.

Cross-axle Differential Locks. Provides full driveline locking - all three axles and all six wheels for maximum performance in the most adverse conditions. Acts in unison with the inter-axle differential lock when the footswitch is actuated and is selected via the dash-mounted switch.

Service Brakes. The 725 features a dual-circuit, two-axle braking system. Full-power hydraulic system actuates self-cleaning caliper disc brakes with independent front and rear circuits and accumulators.

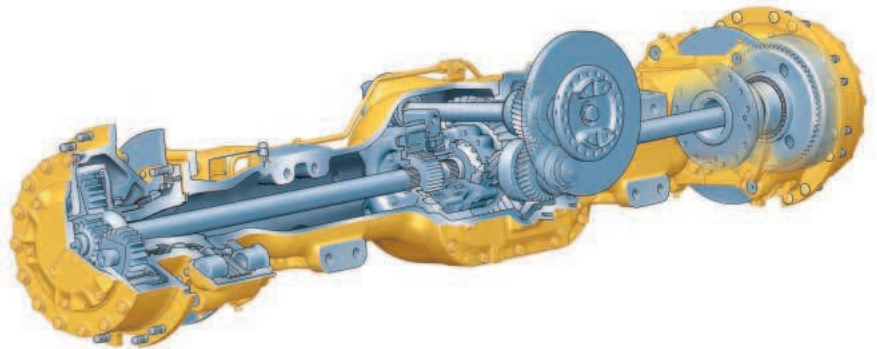

Parking Brake. The parking brake has been moved from the transmission to the center axle. This new design delivers higher heat capacity and abuse resistance.

Fast Hoist Cycle Times. Carried over from the E Series II, fast body raise and lower times mean less time spent in the dump area.

Load-Carrying Capacity. Large target area provides high-load carrying capacity. Its diverging flow design gives clean load ejection, which maximizes production and avoids waste of material carryback.

Operator Comfort

The Operator's Office — High Productivity from a Comfortable, Motivated Operator.



Ride Comfort. The three-point front suspension with its oscillating axle and low pressure ride struts, combined with the new center-mounted cab, offer unrivaled levels of ride comfort for the operator in all driving conditions. Operators remain comfortable and productive throughout the day.

Spacious Two-Person Cab. The 725 features a large two-person cab — 10 percent larger than the E Series II — offering comfortable working space for both the operator and trainer or trainee. All 700 Family articulated trucks use the same spacious cab design.

Air Suspension Seat. The air suspension seat enhances operator comfort with a dual-sided support recliner and thicker cushions. It is fully adjustable to provide an optimal driving position.

Trainer Seat. Full-size trainer seat features a fully padded seat with a backrest and a retractable seatbelt for a secure and comfortable ride.

Storage Space. More storage space to create a secure and uncluttered working environment.

Heating/Ventilation/Air Conditioning. Stay warm or cool in all environments. Twelve vents provide air distribution to keep the operator comfortable and to give rapid defrosting of all windows. Heating and air conditioning are standard and the recirculation filter is positioned for easy servicing.

Sound Levels. Cab mounts are designed to reduce noise and vibration in the cab. All connections to the cab are resiliently mounted and the cab itself makes extensive use of sound absorbing and barrier materials to keep sound levels low.

Steering Column. Offers telescoping and tilting features to provide a comfortable driving position.

Suspended Pedals. New suspended pedals are easier to reach and create more leg and foot room. They also make for easier cleaning of the cab floor.

Ease of Operation

Designed for Simple, Easy Operation, the 725 Allows the Operator to Focus on Production.

Ergonomic Layout. The controls and layout of the cab are designed to make it as easy to operate as your car. Quick and easy to read and simple to operate, the controls on the 725 allow the operator to concentrate on production.

Dash. The wrap-around dash puts all controls within easy reach of the operator. It provides an automotive feel with the industrial strength you would expect from Caterpillar.

Viewing Area. The low sloping hood and placement of the cooling package behind the cab give the operators the best all-around visibility of any truck in the industry. This results in greater operator confidence and speeds up cycle times.

Differential Lock Controls. The switch for the inter-axle differential lock has been positioned in the operator's footrest for ease of operation. A dash-mounted switch is all that is required to select full driveline lock-up. Disengaging the foot switch disengages all differential locks immediately.



Transmission and Hoist Levers. The hoist lever has been redesigned and relocated to provide easy and comfortable operation. The transmission lever continues to offer excellent comfort along with controls for top gear limit, transmission hold and neutral lock.

Electronic Monitoring System (EMS II). Constantly monitors critical machine functions and alerts operators to potentially damaging problems before failures occur.

Durability and Reliability

High Availability Leads to High Productivity.

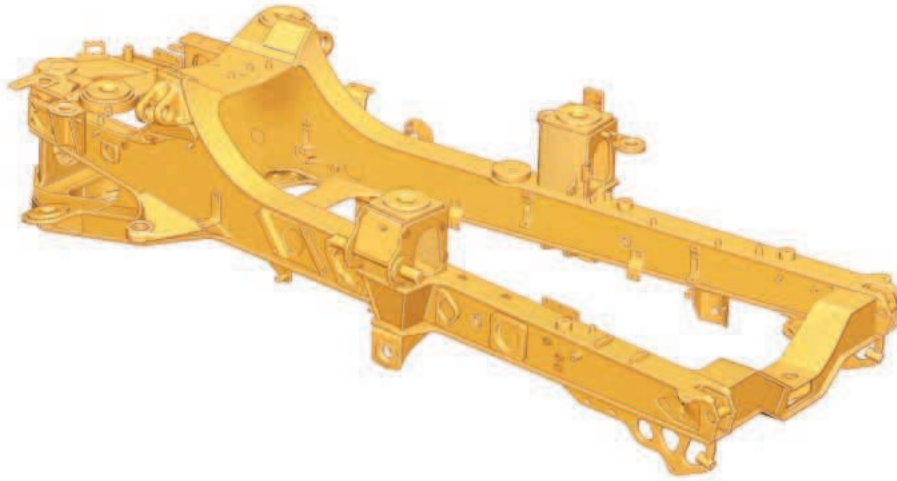

Front Frame. The front frame design features a large box-section, and wide, stiff frame beams to handle torque loads. The divergent frame design decreases stress in the hitch area and optimizes suspension geometry. The frame has been designed to make maximum use of robotic welding for increased durability.

Rear Frame. Twin-box construction minimizes stress concentration and provides low weight with long service life.

Castings. The front and rear frames make extensive use of heavy-duty steel castings to handle stress concentrations.

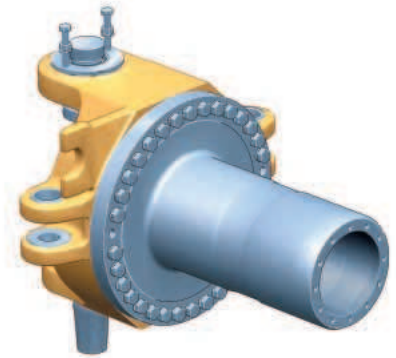

Articulating/Oscillating Hitch.

The articulating hitch provides the truck with steering articulation and the oscillation ensures the truck maintains all wheel ground contact in rough terrain.

Hitch Construction. A two-piece construction featuring a strong and durable cast steel head bolted to a hard wearing forged steel tube. The hitch tube features larger, hardened bearing areas and a hardened thrust face for reduced maintenance and longer life.

Cat Power Train Components. The 725 features purpose-designed earthmoving components from the engine through to the final drives. Proven in articulated trucks and other Cat equipment, these rugged building blocks ensure long life and reliability.

Serviceability

More Time on Production — Less Time and Less Money Spent on Servicing.

Extended Service Intervals. Increased engine oil change and hydraulic oil change intervals and wheel-bearing adjustment completely eliminated.

Test and Lube Points. Test points are grouped together behind the cab and accessible from the ground. Lube points are grouped at the rear of the front frame and the front of the rear frame.

Service Points. Engine and transmission dipstick and fill caps, air and fuel filters and the fuel priming pump are all mounted on the left side of the engine under the hood. Coolant level indicator and fill caps are outside the cab.

Service Access. The cab tilts to the side to provide easier access underneath, which simplifies servicing of the transmission, drive shafts and hydraulic pumps. Accessibility to machine electrical and hydraulic interfaces has also been improved. They are located on the right side of the cab, behind a removable cab body panel.

Radiator. The radiator package is located behind the cab, which provides improved protection from frontal impacts and offers improved access to both inlet and outlet sides of the radiator.

Extended Life Coolant. Extends the change interval as well as improving water pump life by reducing aluminum corrosion.

Hood. The hood is raised and lowered electrically requiring minimal operator effort when servicing.



Electrical Service Center. Located inside the cab, this provides a power port, diagnostic connector and the Cat data link connector.

Cat Data Link Connector. Provides a connection point for a laptop computer running Electronic Technician (ET) software.

Truck Transport. The suspension system eliminates the need to lower the suspension when transporting the truck, reducing maintenance and downtime.

Complete Customer Support

Cat Dealer Services Help You Operate Longer with Lower Costs.



Selection. Make detailed comparisons of the machines you are considering before you buy. What are the job requirements, machine attachments and operating hours? What is your need for machine availability and do you need or have the proper loading tool match? Your Cat dealer can help.

Custom Products. The 725 is compatible with a wide range of Caterpillar and auxiliary equipment manufacturers' specialized products. For more information, contact your local Cat dealer.

Purchase. Look past initial price, look at the value the 725 offers. Consider the resale value, compare productivity and day-to-day operating costs and fuel consumption. Consult your local Cat dealer for financing options.

Operation. For the best operating techniques to increase productivity and your profit, turn to your Cat dealer for the latest training literature and trained staff.

Maintenance. Repair option programs guarantee the cost of repairs up front. Diagnostic programs such as S•O•SSM and Technical Analysis help you avoid unscheduled repairs.

Replacement. Repair or rebuild? Cat Articulated Trucks are designed for a longer life with rebuildable components. Your Cat dealer can help you evaluate the cost involved so you can make the right choice.

Product Support. The 725 offers easy maintenance with combined service points and extended service intervals to keep the machine running longer. Your local Cat dealership offers unsurpassed worldwide parts support, trained technicians and customer support agreements.

Warranty. Your local Cat dealer is there to support and protect you. Extended warranty options are also available.

CAT.com. For more complete information on Cat products, dealer services and industry solutions, visit us on the Web at www.CAT.com.

Engine

Engine Model	Cat 3176C ATAAC EUI	
Gross Power	223.7 kW	300 hp
Flywheel Power	209 kW	280 hp
ISO 9249	209 kW	280 hp
EEC 80/1269	209 kW	280 hp
SAE J1349	207 kW	277 hp
Bore	125 mm	4.9 in
Stroke	140 mm	5.5 in
Displacement	10.3 L	629 in ³

- The 725 meets Tier 2/EU Stage II emission specifications for the U.S. and Europe through 2005.
- No engine derating required below 4572 m (15,000 ft).

Weights

Rated Payload	23.6 tonnes	26 tons
---------------	-------------	---------

Body Capacities

Heaped SAE 2:1	14.3 m ³	18.8 yd ³
Struck	11.1 m ³	14.5 yd ³
Heaped SAE 1:1	17.5 m ³	16.8 yd ³

Transmission

Forward 1	7.1 kph	4.4 mph
Forward 2	13.4 kph	8.4 mph
Forward 3	20.4 kph	12.7 mph
Forward 4	31.2 kph	19.5 mph
Forward 5	43.5 kph	27.2 mph
Forward 6	51.3 kph	32.1 mph
Reverse 1	7.9 kph	4.9 mph

Sound Levels

Interior Cab	76 dB(A)
--------------	----------

- The operator sound exposure Leq (equivalent sound pressure level) measured according to the work cycle procedures specified in ANSI/SAE J1166 OCT 98 is 76 dB(A), for the cab offered by Caterpillar, when properly installed and maintained and tested with the doors and windows closed.
- Hearing protection may be needed when operating with an open operator station and cab (when not properly maintained or doors/windows open) for extended periods or in noisy environments.

Operating Weights

Front Axle - Empty	12 900 kg	28,445 lb
Center Axle - Empty	5210 kg	11,488 lb
Rear Axle - Empty	4620 kg	10,187 lb
Total - Empty	22 730 kg	50,120 lb

Front Axle - Rated Load	1500 kg	3,307 lb
Center Axle - Rated Load	10 750 kg	23,704 lb
Rear Axle - Rated Load	11 340 kg	25,005 lb
Total - Rated Load	23 590 kg	52,016 lb

Front Axle - Loaded	14 400 kg	31,752 lb
Center Axle - Loaded	15 960 kg	35,192 lb
Rear Axle - Loaded	15 960 kg	35,192 lb
Total - Loaded	46 320 kg	102,136 lb

Body Plate Thickness

Front	8 mm	0.31 in
Scow	14 mm	0.55 in
Side	12 mm	0.47 in
Base	14 mm	0.55 in

Service Refill Capacities

Fuel Tank	310 L	82 gal
Cooling System	85 L	22.5 gal
Hydraulic System	150 L	39.3 gal
Engine Crankcase	31 L	8.2 gal
Transmission	36 L	9.4 gal
Final Drives/Differential	132 L	34.6 gal
Output Transfer Gear Box	18 L	4.8 gal

Body Hoist

Raise time	10 Seconds
Lower time	7 Seconds

Steering

Flow Rate	153 L/min	40 gal/min
-----------	-----------	------------

Standards

Brakes	SAE J/ISO 3450:1998
Cab/FOPS	SAE J231 JAN81 and ISO 3449:1992 Level II
Cab/ROPS	SAE J1040 May 1994 and ISO 3471:1994

Dimensions

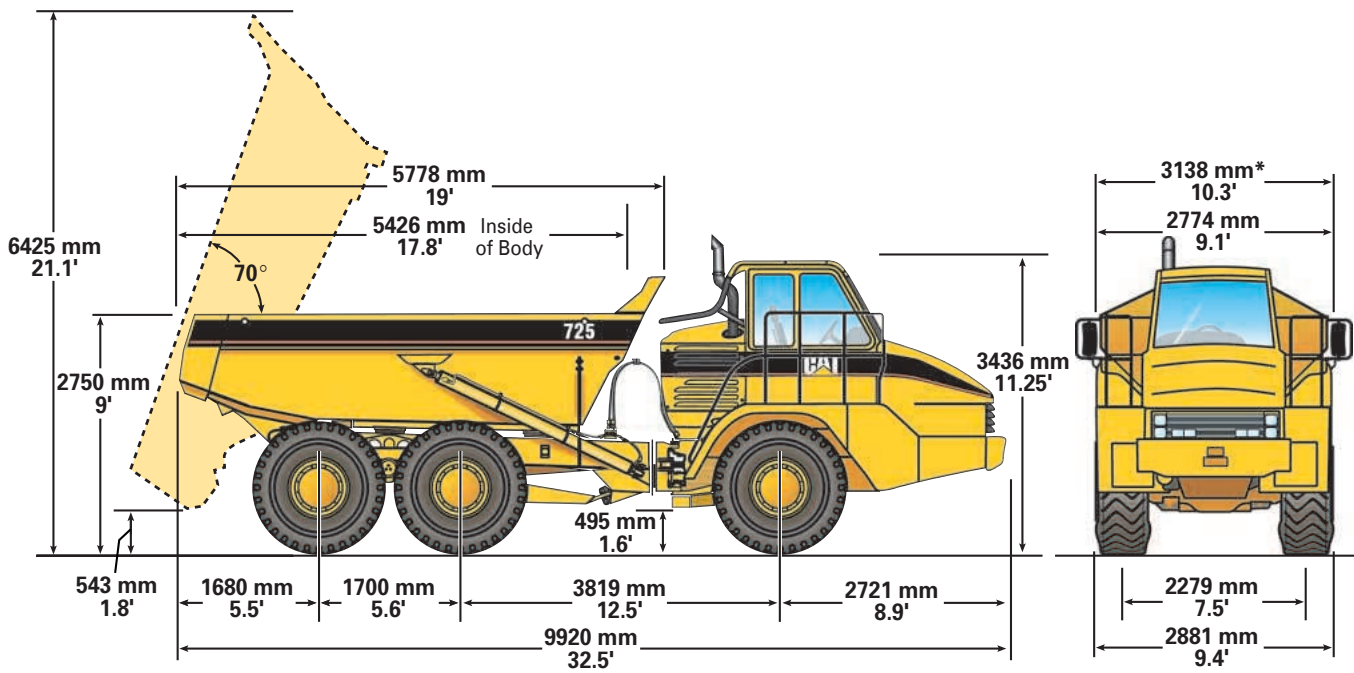

* if equipped with a scissor tailgate

Turning Circle

Dimensions are for machines equipped with 23.5R25 tires.

Turning dimensions

Steer angle — left/right	45°
SAE turning radius	7255 mm 286 in
Clearing radius	7590 mm 299 in
Inside radius	3714 mm 146 in
Aisle width	4964 mm 195 in

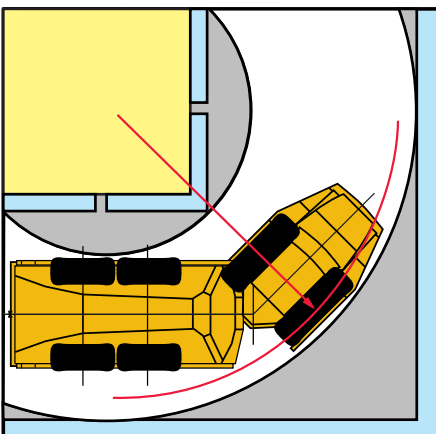

Optimal Loader/Truck Pass Matching

Hydraulic Excavators	345B L Series II	330B L	325B L
Passes	3-4	4-5	5-6

Wheel Loaders	966G	962G	950G
Passes	3-4	3-4	4

An optimum system match gives you a major productivity advantage. The 725 is an excellent match for the Cat 345B L Series II, 330B L, and 325B L Hydraulic Excavators; and Cat 966G, 962G and 950G Wheel Loaders. This results in increased production and lower system costs per unit of volume moved.

Gradeability/Speed/Rimpull

To determine performance, read from Gross Weight down to % Total Resistance. Total Resistance equals actual % grade plus 1% for each 10 kg/metric ton (20 lb/ton) of Rolling Resistance. From this point, read horizontally to the curve with the highest attainable speed range. Then, go down to Maximum Speed. Usable Rimpull depends on traction available.

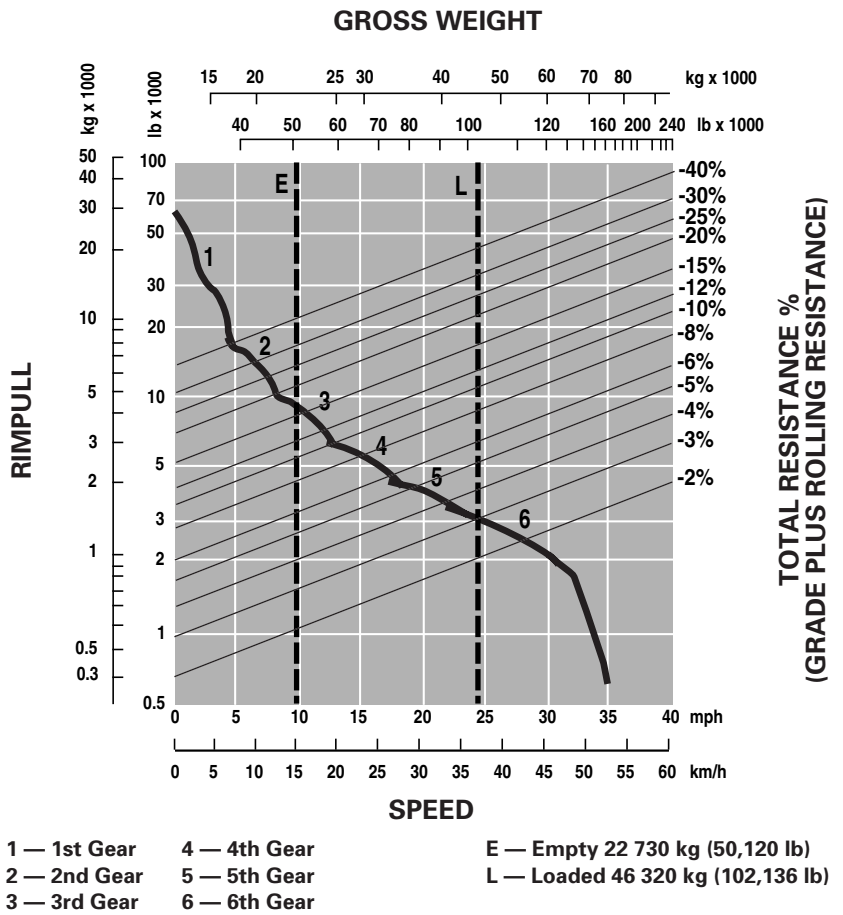

Retarding Performance

To determine performance, read from Gross Weight down to % Effective Grade. Effective Grade equals actual % favorable grade plus 1% for each 10 kg/metric ton (20 lb/ton) of Rolling Resistance. From this point, read horizontally to the curve with the highest attainable speed range. Then, go down to Maximum Speed. Retarding effect on these curves represents full application of the retarder.

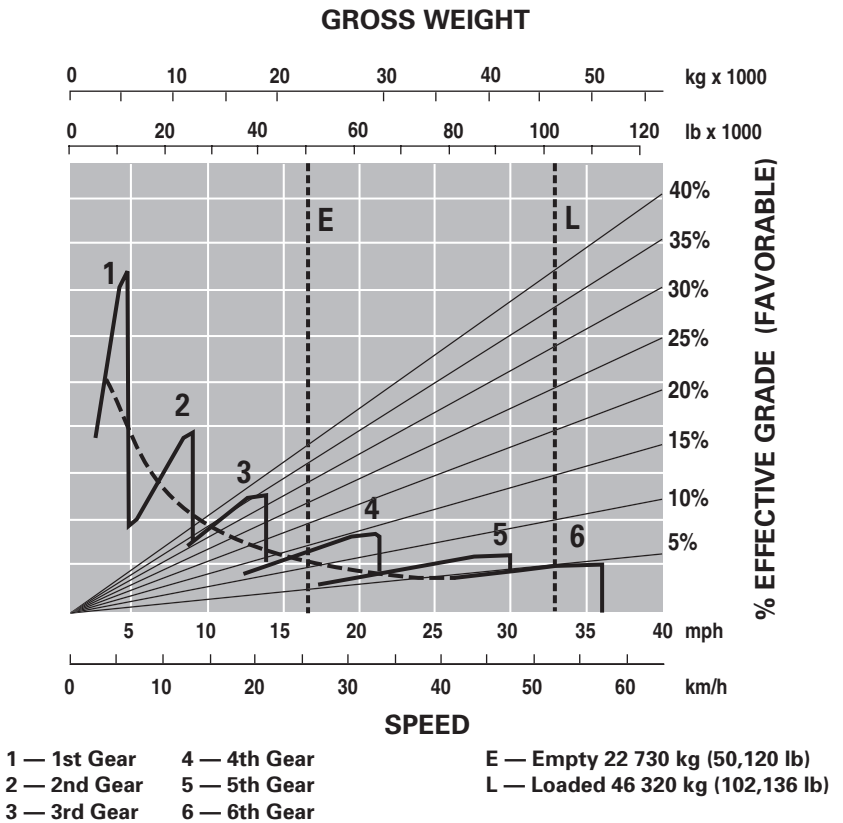

Standard Equipment

Standard equipment may vary. Consult your Caterpillar dealer for details.

Air conditioning with R134A refrigerant
Air vents, adjustable
Back up alarm
Body, adapted for exhaust heat
Electrical system: 24-volt, 2.5A 24- to 12-volt converter
Glass windows, laminated and tinted (front), toughened and tinted (rear)
Guards: rear window and radiator, crankcase and axle
Headlights, four
Heater and defroster with three speed fan
Horn, electric
Lights: cab interior, front, side, rear, two reversing/working lights, two stop/tail lights, front and rear direction indicators
Mirrors, left and right
Mud flaps, body mounted
Radio ready
Retarder
ROPS/FOPS cab, with full instrumentation:
- Electronic Monitoring System panel: alternator, coolant temperature, brake oil pressure, engine oil pressure, low fuel indicator
- Gauges: fuel (in cab), torque converter temperature
- Indicator Lights: direction, hazard, headlights, high beam only, cross axle differential lock-up, parking brake, transmission hold indicator
- Meters: service hour meter, speedometer, tachometer
Seat, fully adjustable, air suspension

Seat, padded companion/trainer
Seat belts, two retractable
Secondary steering
S•O•SSM sampling valves
Spill guard, front, integral part of fabricated body
Standard differentials with clutched cross-axle diff locks for all axles
Starting receptacle, electric, remote
Storage: two cup holders, thermos receptacle, under seat storage, door pocket, behind seat storage, coat hook
Sun visor
Tires, six 23.5R25, radial
Tow pins, front and rear
Vandalism protection: lockable caps for fuel tank and hydraulic oil tank
Windows opening side, tinted
Windshield wiper and washer, intermittent (front)
Windshield wiper and washer, intermittent (rear)

Optional Equipment

Optional equipment may vary. Consult your Caterpillar dealer for details.

Autolube installation for automatic greasing of bearings
Body connection for exhaust heat
Body liners
Cold start attachment
Ether start canister
Fast fuel fill
Heated rearview mirrors

Tailgate:
- Scissor-type
Tires: optional tire sizes and tread patterns available
Tool kit

725 Articulated Truck

AEHQ5394-02 (2-03)

Replaces AEHQ5394-01

For more complete information on Cat products, dealer services,
and industry solutions, visit us on the web at www.CAT.com

© 2003 Caterpillar
Printed in U.S.A.

Materials and specifications are subject to change without notice.
Featured machines in photos may include additional equipment.
See your Caterpillar dealer for available options.

CATERPILLAR[®]