

# 735

## Articulated Truck



### Engine

Engine Model	Cat <sup>®</sup> 3406E ATAAC EUI	
Gross Power	294 kW	394 hp
Flywheel Power	272 kW	365 hp

### Weights

Rated Payload	32.7 tonnes	36 tons
---------------	-------------	---------

### Body Capacities

Heaped SAE 2:1	19.7 m <sup>3</sup>	25.8 yd <sup>3</sup>
----------------	---------------------	----------------------

# 735 Articulated Truck

*The 735 Caterpillar® Articulated Truck is a world-leading earthmoving solution.*

---

## Performance and Productivity - Power Train

The 3406E air-to-air aftercooled (ATAAC) engine delivers higher power and a more aggressive torque rise. A new eight-speed electronically controlled transmission provides a wider operating range with four additional forward gears. **pg. 4**

---

## Performance and Productivity - Suspension and Traction Control

Cross-axle differential locking system provides full driveline locking for maximum performance in adverse conditions. Three-point front suspension provides a smoother ride, allowing the operator to travel faster over rough terrain. **pg. 5**

---

## Operator Comfort

Larger center-mounted cab, oscillating front axle, air suspension seat, full-size trainer seat and increased storage space provide exceptional operator comfort. **pg. 6**

---

## Complete Customer Support

Your Cat dealer offers a wide range of services that can be set up under a customer support agreement when you purchase your equipment. The dealer will help you choose a plan that can cover everything from machine configuration to eventual replacement. **pg. 10**

*Best in its class, the 735 offers proven reliability and durability, high performance, low fuel consumption, operator comfort and low operating costs.*



---

### **Ease of Operation**

Ergonomically designed wrap-around dash, tilt and telescoping steering wheel, easy-to-reach controls and better all-around viewing promote fast, confident machine operation. **pg. 7**

---

### **Durability and Reliability**

The 735 has built-in durability and reliability. Cat purpose-built articulated truck drivetrain components, redesigned front frame and hitch ensure maximum performance in the toughest applications. **pg. 8**

---

### **Serviceability**

Longer service intervals and easier maintenance result in better machine availability, as well as lower owning and operating costs. **pg. 9**



## Performance and Productivity - Power Train

*Integrated power train with more power, greater performance and lower fuel consumption — the power to do more work.*



**3406E Electronic Engine.** The electronic version of this proven engine delivers higher power, durability and complete system integration of the engine and transmission for maximum efficiency.

**High Torque Rise.** Provides unequaled lugging force during acceleration, on steep grades and in tough underfoot conditions.

**Air-to-Air Aftercooling (ATAAC).**

Provides improved fuel economy by packing cooler, denser air into cylinders for more complete combustion of fuel and lower emissions.

**Electronic Control Module (ECM).**

Advanced Diesel Engine Management III (ADEM III) offers improved emissions, performance and advanced troubleshooting.

**Fuel Efficiency.** The electronically controlled, computer actuated unit injection fuel system has high injection pressure for complete fuel combustion, greater fuel efficiency and reduced emissions.

**Engine Construction.** Since 1974, the 3406 engine has been the benchmark for heavy-duty reliability and performance. The latest electronic version incorporates major updates to keep it ahead of the rest. Cylinder head with overhead camshaft and a pendulum shock absorber improve efficiency and increase reliability.

**Electronic Transmission.** The new eight-speed electronically controlled transmission is designed specifically for the articulated truck and its applications. It features Electronic Clutch Pressure Control (ECPC) to manage shift torque and provide exceptional smoothness.

**Controlled Throttle Shifting (CTS).** CTS significantly reduces power train stress and clutch wear by controlling engine speed, torque converter lock-up and transmission clutch engagements.

**Engine Compression Brake.** The standard Jake Brake<sup>®</sup> provides extra braking effort on downhill grades. It is an excellent match for the 3406E engine, turning it into a power-absorbing air compressor. It has very fast response time and produces no additional heat, so it can be used continuously. Four modes of operation with three steps of retardation provide an optimum match between operating conditions and retarding power.

## Performance and Productivity - Suspension and Traction Control

*Suspension systems and traction control — delivering power to the ground in all conditions.*

**Front Suspension.** The three-point front suspension oscillates  $\pm 6^\circ$  to provide a smoother ride, allowing the operator to travel faster over rough terrain and softening impact loads on structures and components.

**Rear Suspension.** Features a walking beam geometry that provides a stable ride for excellent load retention.

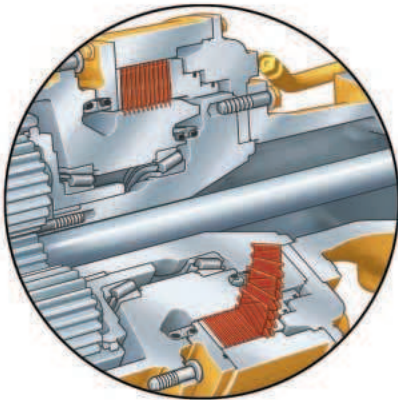

*Service brake detail*

**Enclosed, Oil-Cooled Brakes.** Multi-plate oil-immersed brakes are fitted to both front and center axles. These brakes provide outstanding stopping capability, while maintaining maximum durability and low wear characteristics.

**Traction Control.** The traction control system is comprised of a wet clutched inter-axle differential and wet clutched cross-axle differentials. All differentials can be engaged and disengaged on-the-go for maximum versatility. When used together, the differentials provide 100 percent driveline locking.

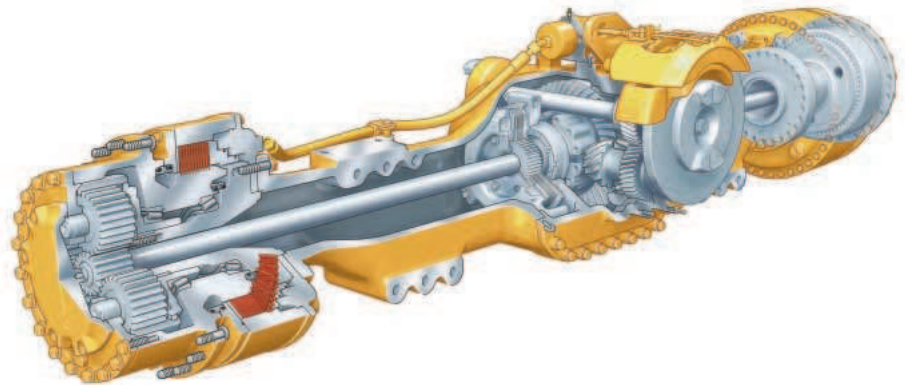

**Inter-Axle Differential Lock.** Locks all three axles in unison and modifies torque distribution for excellent traction in poor underfoot conditions and on grades. It is operated by a switch located at the footrest.

**Cross-Axle Differential Locks.** Provides full driveline locking — all three axles and all six wheels — for maximum performance in the most adverse conditions. Acts in unison with the inter-axle differential lock when the footswitch is actuated and the dash-mounted switch is selected.

## Operator Comfort

*The operator's office — high productivity from a comfortable, motivated operator.*



**Ride Comfort.** The three-point front suspension with its oscillating axle and low pressure ride struts, combined with the new center-mounted cab, offers unrivaled levels of ride comfort for the operator in all driving conditions. Operators remain comfortable and productive throughout the day.

**Spacious Two-Person Cab.** The 735 features a large two-person cab — 41 percent larger than the E Series II — offering comfortable working space for both the operator and trainer or trainee. All 700 Family articulated trucks use the same spacious cab design.

**Air Suspension Seat.** Enhances operator comfort with a dual-sided support recliner and thicker cushions. It is fully adjustable to provide an optimal driving position.

**Trainer Seat.** Full-size trainer seat features a fully padded seat with a backrest and a wide, retractable seatbelt for a secure and comfortable ride. The trainer seat is positioned next to the operator seat, giving both the operator and trainer a clear view of the instrument panel, controls and the road.

**Storage Space.** More storage space to create a safe, secure and uncluttered working environment.

**Heating/Ventilation/Air Conditioning.** Twelve vents provide air distribution to keep the operator comfortable and to provide rapid defrosting of all windows. Heating, air conditioning and defrosting are standard. The recirculation filter is positioned for easy servicing.

**Sound Levels.** Cab mounts are designed to reduce noise and vibration in the cab. All connections to the cab are resiliently mounted. The operator's station makes extensive use of sound-absorbing and barrier materials to keep sound levels low.

**Steering Column.** Offers telescoping and tilting features to provide a comfortable driving position.

## Ease of Operation

*Designed for simple, easy operation, the 735 allows the operator to focus on production.*

**Ergonomic Layout.** The controls and layout of the cab are designed to make it as easy to operate as your car. Quick, easy to read and simple to operate, the controls and gauges on the 735 allow the operator to concentrate on production.

**Dash.** The wrap-around dash puts all controls within easy reach of the operator. It provides an automotive feel with the industrial strength you would expect from Caterpillar.

**Viewing Area.** The low sloping hood, made possible by placing much of the cooling package behind the cab, gives the operator excellent all-around visibility. The larger glass area and central operator position further enhance visibility, resulting in more operator confidence and faster cycle times.

**Differential Lock Controls.** The switch for the inter-axle differential lock has been positioned in the operator's footrest for ease of operation. An additional dash-mounted switch is all that is required to select full driveline lock-up. Disengaging the foot switch disengages all differential locks immediately.

**Transmission and Hoist Levers.** The hoist lever has been redesigned and relocated to provide easy and comfortable operation. The transmission lever continues to offer excellent comfort along with controls for top gear limit, transmission hold and neutral lock.



**Suspended Pedals.** The suspended pedals are easier to operate and reach, while creating more leg and foot room. They also make for easier cleaning of the cab floor by keeping the pedals out of the dirt.

**Electronic Monitoring System (EMS III).** Constantly monitors critical machine functions, alerts operators to potentially damaging problems before failures occur, and indicates when certain functions are in use. EMS III offers added memory and improved performance. It is also flashable, allowing the software to be easily updated. The system continues to use three levels of alert.

## Durability and Reliability

*High availability leads to high productivity. Excellent durability keeps ownership costs low.*

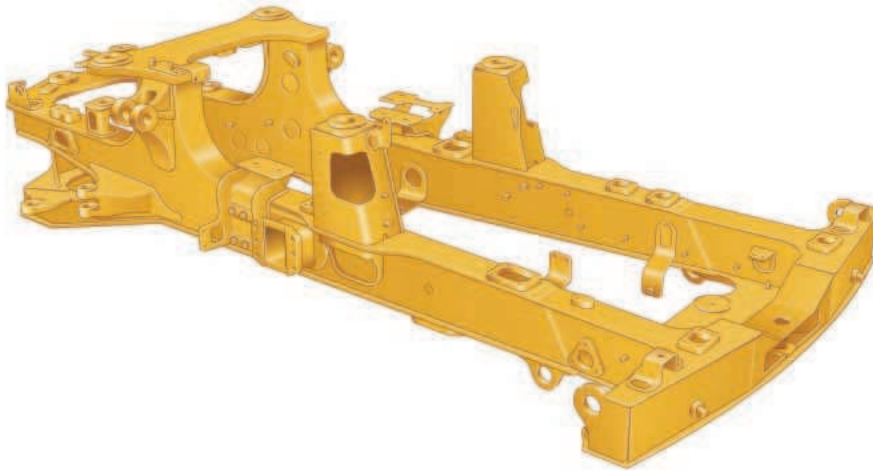

**Front Frame.** The front frame design features a large box section and wide, stiff frame beams to handle torque loads. The divergent frame design decreases stress in the hitch area and optimizes suspension geometry. The frame design makes maximum use of robotic welding for increased durability.

**Rear Frame.** Twin-box construction was developed for the E-Series II trucks and is proven in countless applications throughout the world. The design minimizes stress concentrations and provides low weight with long service life.

**Castings.** Both front and rear frames make extensive use of heavy-duty steel castings to handle stress concentrations.

**Suspension.** Three-point front suspension provides unparalleled ride quality. It also protects the truck from the most adverse road conditions by absorbing shock loads that would otherwise reach the frame.

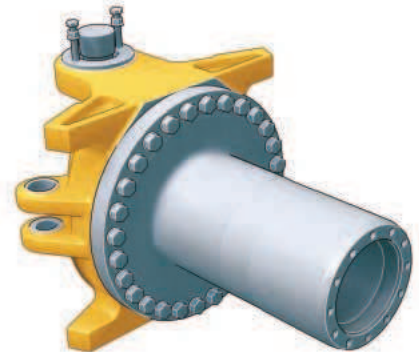

**Articulating/Oscillating Hitch.** The articulating hitch provides the truck with steering articulation, and the oscillation ensures all-wheel ground contact in rough terrain.

**Hitch Construction.** A two-piece construction featuring a strong and durable cast steel head bolted to a hard-wearing forged steel tube. The hitch tube has hardened bearing areas and a hardened thrust face for reduced maintenance and longer life.

**Cat Power Train Components.** All major components have been purpose-designed for earthmoving applications. In fact, many of the major components have been designed specifically for articulated trucks.



## Serviceability

*More time on production, less time and money spent on servicing.*

**Extended Service Intervals.** Increased engine oil change and hydraulic oil change intervals.

**Test and Lube Points.** Test points are grouped together behind the cab and are accessible from the ground. Lube points are grouped at the rear of the front frame and the front of the rear frame.

**Service Points.** Engine dipstick and fuel cap, air and fuel filters and the fuel priming pump are all mounted on the left side of the engine under the hood, with the transmission dipstick and filler on the right side. Coolant level indicator and fill cap are outside the cab.

**Radiator.** The radiator package is located behind the cab, which provides improved access to the inlet and outlet sides of the radiator. The ATAAC radiator is located at the front of the truck.

**Extended Life Coolant.** Extends the change interval and improves component life by reducing aluminum corrosion.

**Hood.** The hood is raised and lowered electrically, minimizing operator effort when servicing the machine.

**Electrical Service Center.** Located inside the cab, this service center provides a power port, diagnostic connector and Cat Data Link connector.

**Cat Data Link Connector.** The Cat Data Link connector provides a plug-in using a laptop computer with Electronic Technician (ET) software. The Cat Data Link port performs programming functions on all electronic controls.



**Service Access.** The cab tilts to the side to provide easier access underneath, which simplifies servicing of the transmission, drive shafts and hydraulic pumps. Accessibility to machine electrical and hydraulic interfaces has also been improved. They are located on the right side of the cab, behind a removable cab body panel.

**Truck Transport.** The suspension system eliminates the need to lower the suspension when transporting the truck, reducing maintenance and downtime.

## Complete Customer Support

*Cat dealer services help you operate longer with lower costs.*



**Selection.** Make detailed comparisons of the machines you are considering before you buy. What are the job requirements, machine attachments and operating hours? What is your need for machine availability and do you have the proper loading tool match? Your Cat dealer can help.

**Custom Products.** The 735 is compatible with a wide range of Caterpillar and auxiliary equipment manufacturers' specialized products. For more information, contact your local Cat dealer.

**Purchase.** Look past the initial price, look at the value the 735 offers. Consider the resale value, compare productivity and day-to-day operating costs and fuel consumption. Consult your local Cat dealer for financing options.

**Operation.** For the best operating techniques to increase productivity and your profit, turn to your Cat dealer for the latest training literature and trained staff.

**Maintenance.** Repair option programs guarantee the cost of repairs up front. Diagnostic programs such as S-O-S<sup>SM</sup> and Technical Analysis help you avoid unscheduled repairs.

**Replacement.** Repair or rebuild? Caterpillar trucks are designed for longer life with rebuildable components. Your Cat dealer can help you evaluate the cost involved so you can make the right choice.

**Product Support.** The 735 offers easy maintenance with combined service points and extended service intervals to keep the machine running longer. Your local Cat dealership will be with you every step of the way with its unsurpassed worldwide parts support, trained technicians and customer support agreements.

**Warranty.** Your local Cat dealer is there to support and protect you. Extended warranty options are also available.

**Cat.com.** For more complete information on Cat products, dealer services and industry solutions, visit us on the Web at [www.Cat.com](http://www.Cat.com).

## Engine

Engine Model	Cat 3406E ATAAC EUI	
Gross Power	294 kW	394 hp
Flywheel Power	272 kW	365 hp
ISO 9249	272 kW	365 hp
EEC 80/1269	272 kW	365 hp
Bore	137 mm	5.4 in
Stroke	165 mm	6.5 in
Displacement	14.64 L	893 in <sup>3</sup>

- The 735 meets Tier 2/Stage II emission specifications for the U.S. and Europe through 2005.
- No engine derating required below 3353 m (11,000 ft).

## Weights

Rated Payload	32.7 tonnes	36 tons
---------------	-------------	---------

## Body Capacities

Heaped SAE 2:1	19.7 m <sup>3</sup>	25.8 yd <sup>3</sup>
Struck	14.7 m <sup>3</sup>	19.3 yd <sup>3</sup>
Heaped SAE 1:1	24.3 m <sup>3</sup>	31.8 yd <sup>3</sup>

## Transmission

Forward 1	6.8 kph	4.2 mph
Forward 2	10.9 kph	6.8 mph
Forward 3	14.2 kph	8.8 mph
Forward 4	19.3 kph	12 mph
Forward 5	26.4 kph	16.4 mph
Forward 6	37.1 kph	23 mph
Forward 7	49.4 kph	30.7 mph
Forward 8	55.8 kph	34.7 mph
Reverse 1	7.9 kph	4.9 mph

## Sound Levels

Interior Cab	79 dB(A)
--------------	----------

- Operator sound exposure Leq (equivalent sound pressure level) measured according to work cycle procedures specified in ANSI/SAE J1166 OCT 98 is 79 dB(A), for the cab offered by Caterpillar, when properly installed and maintained and tested with doors and windows closed.
- Hearing protection may be needed when operating with an open operator station and cab (when not properly maintained or doors/windows open) for extended periods or in noisy environments.

## Operating Weights

Front Axle - Empty	17 647 kg	38,905 lb
Center Axle - Empty	6461 kg	14,244 lb
Rear Axle - Empty	5750 kg	12,676 lb
Total - Empty	29 858 kg	65,825 lb

Front Axle - Rated Load	4032 kg	8,888 lb
Center Axle - Rated Load	14 334 kg	31,601 lb
Rear Axle - Rated Load	14 334 kg	31,601 lb
Total - Rated Load	32 700 kg	72,090 lb

Front Axle - Loaded	21 679 kg	47,793 lb
Center Axle - Loaded	20 795 kg	45,845 lb
Rear Axle - Loaded	20 084 kg	44,277 lb
Total - Loaded	62 558 kg	137,915 lb

## Body Plate Thickness

Front	8 mm	0.31 in
Scow	14 mm	0.55 in
Side	12 mm	0.47 in
Base	14 mm	0.55 in

## Service Refill Capacities

Fuel Tank	560 L	148 gal
Cooling System	80 L	21.1 gal
Hydraulic System	233 L	61.6 gal
Engine Crankcase	38 L	10 gal
Transmission	72 L	19 gal
Final Drives/Differential	80 L	21 gal
Output Transfer Gear Box	21 L	5.6 gal

## Body Hoist

Raise time	11 Seconds
Lower time	7 Seconds

## Standards

Brakes	SAE J/ISO 3450-1998
Cab/FOPS	SAE J231 JAN81 and ISO 3449-1992 Level II
Cab/ROPS	SAE J1040 May 1994 and ISO 3471-1994

## Turning Circle

Dimensions are for machines equipped with 26.5R25 tires.

### Turning dimensions

Steer angle — left/right	45°	
SAE turning radius	8138 mm	320.4 in
Clearance radius	8595 mm	338.4 in
Inside radius	4182 mm	164.7 in
Aisle width	5637 mm	221.9 in

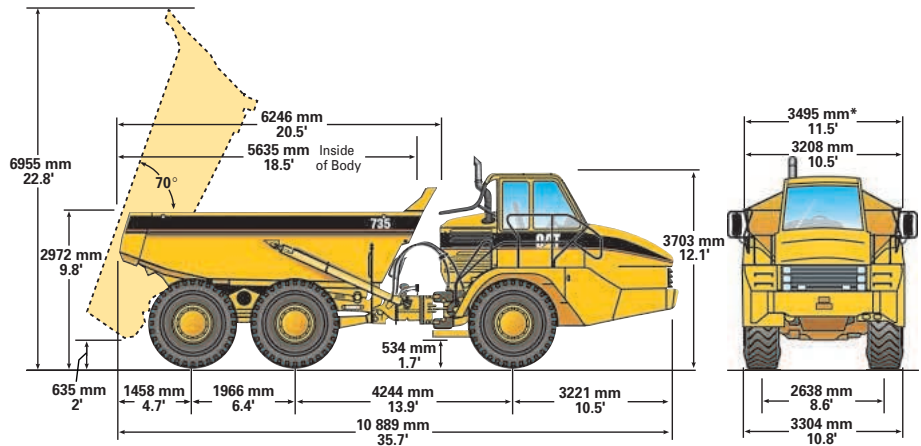
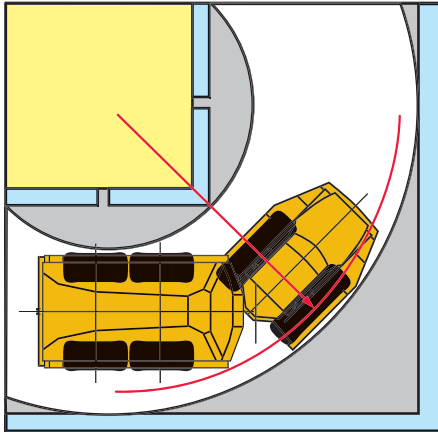

\* If equipped with a scissor tailgate.

## Optimal Loader/Truck Pass Matching

Hydraulic Excavators	385B L ME	365B II L ME	345B II L ME
Loader Capacity (Tonnes) – 50 min hr	954-1193	750-1100	665-805
Loader Capacity (Tons) – 50 min hr	1049-1314	825-1210	735-885
Passes	3	4	5

Wheel Loaders	988G	980G	972G	966G	962G
Loader Capacity (Tonnes) – 50 min hr	565-790	590-650	490-565	400-535	325-400
Loader Capacity (Tons) – 50 min hr	625-870	650-715	540-625	440-590	360-440
Passes	3	3-4	4-5	5	6

An optimum system match gives you a major productivity advantage. The 735 is an excellent match for the Cat 345B II L, 365B II L, and 385B L Mass Excavators; and Cat 966G, 972G, 980G and 988G Wheel Loaders. This results in increased production and lower system costs per unit of volume moved.

## Gradeability/Speed/Rimpull

To determine performance, read from Gross Weight down to % Total Resistance. Total Resistance equals actual % grade plus 1% for each 10 kg/metric ton (20 lb/ton) of Rolling Resistance. From this point, read horizontally to the curve with the highest attainable speed range. Then, go down to Maximum Speed. Usable Rimpull depends on traction available.

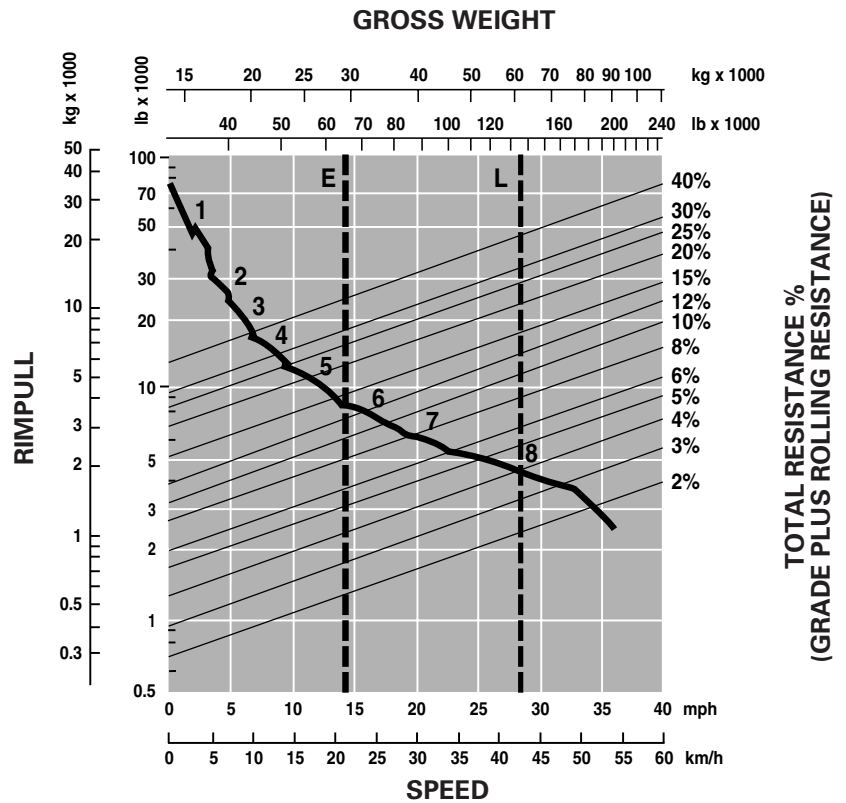

## Retarding Performance

To determine performance, read from Gross Weight down to % Effective Grade. Effective Grade equals actual % favorable grade plus 1% for each 10 kg/metric ton (20 lb/ton) of Rolling Resistance. From this point, read horizontally to the curve with the highest attainable speed range. Then, go down to Maximum Speed. Retarding effect on these curves represents full application of the retarder.

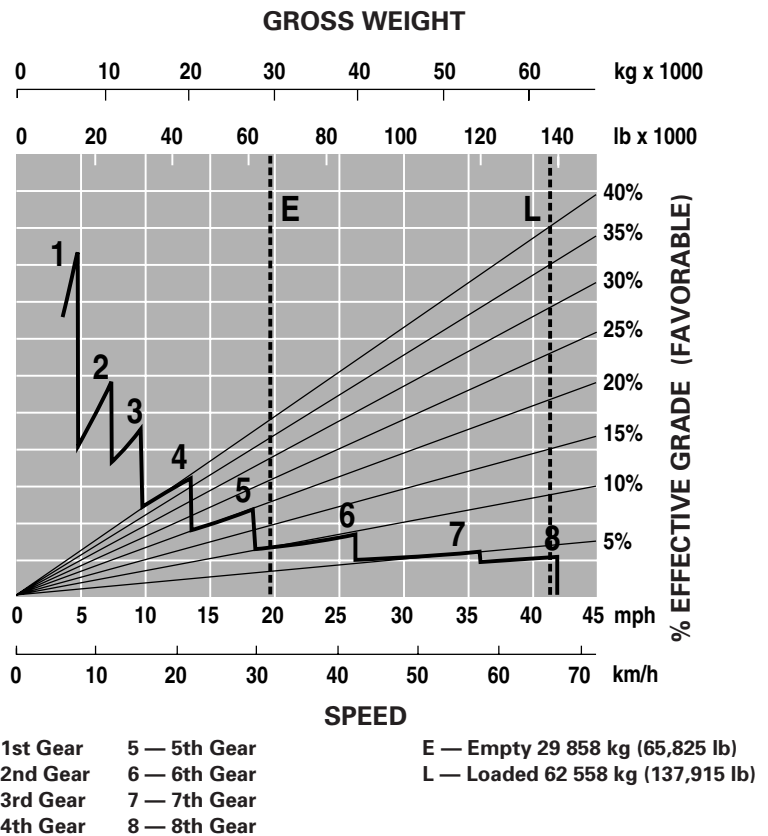

## Standard Equipment

*Standard equipment may vary. Consult your Caterpillar dealer for details.*

Air conditioning with R134A refrigerant

Air vents, adjustable

Back up alarm

Body, adapted for exhaust heat

Differentials, with clutched cross-axle diff locks for all axles

Electrical system: 24 volt, 2.5A 24 to 12 volt converter

Engine compression brake

Ether starting aid

Glass windows, toughened and tinted, front and rear

Guards: rear window and radiator, crankcase and axle

Headlights, four with dimmer switch

Heater and defroster with three-speed fan

Horn, electric

Lights: cab interior, front, side rear, two reversing/  
working lights, two stop/tail lights

Mirrors, main and auxiliary, left and right

Mud flaps, body mounted

Radio ready

ROPS/FOPS cab with full instrumentation including:

- Electronic Monitoring System panel: alternator, coolant temperature, brake oil pressure, engine oil pressure, low fuel indicator
- Gauges: fuel (in cab), torque converter temperature.
- Indicator lights: direction, hazard, headlights, high beam only, differential lock-up, parking brake, transmission/torque converter lock-up
- Meters: service hour meter, speedometer, tachometer

Seat, fully adjustable, air suspension

Seat, padded companion/trainer

Seatbelts, two retractable

S•O•S<sup>SM</sup> sampling valves

Starting receptacle, electric, remote

Storage - two cup holders, Thermos receptacle, under seat storage, door pocket, behind seat storage, coat hook

Sun visor

Tires, 26.5R25, radial, Michelin XADN

Tow pins, front and rear

Vandalism protection: lockable caps for fuel tank, hydraulic oil tank and radiator

Windows, opening side, tinted

Windshield wiper and washer, intermittent (front)

Windshield wiper and washer, intermittent (rear)

## Optional Equipment

*Optional equipment may vary. Consult your Caterpillar dealer for details.*

Autolube installation for automatic greasing of bearings  
Body connection for exhaust heat  
Body liners  
Cold start attachment  
Ether start canister  
Fast fuel fill  
Heated rearview mirrors

Tailgate:  
-Scissor-type  
Tires: optional tire sizes and tread patterns available  
Tool kit

# 735 Articulated Truck

AEHQ5435-01 (5-03)

Replaces AEHQ5435

For more complete information on Cat products, dealer services,  
and industry solutions, visit us on the web at [www.CAT.com](http://www.CAT.com)

© 2003 Caterpillar  
Printed in U.S.A.

Materials and specifications are subject to change without notice.  
Featured machines in photos may include additional equipment.  
See your Caterpillar dealer for available options.

**CATERPILLAR**<sup>®</sup>