

# 769D

Off-Highway Truck



## Engine

Engine Model	Caterpillar 3408E	
Gross Power	386 kW	518 hp
Flywheel Power	363 kW	487 hp

## Weights

Gross Machine Weight	71 400 kg	157,000 lb
----------------------	-----------	------------

## Operating Specifications

SAE (2:1) Capacity	24.2 m <sup>3</sup>	31.7 yd <sup>3</sup>
Nominal Payload	36.4 tonnes	40.0 tons

# 769D Off-Highway Truck

*Engineered for performance, designed for comfort and built to last.*

---

## Power Train - Engine

The power train features the Caterpillar® 3408E Diesel engine and Advanced Modular Cooling System for efficient operation. **pg. 4**

---

## Power Train - Transmission

The Cat® seven-speed, power shift transmission, matched with the direct-injection 3408E diesel engine provides constant power over a wide range of operating speeds. **pg. 6**

---

## Engine/Power Train Integration

The Caterpillar Data Link System electronically combines engine, transmission, brake and operational information to optimize overall truck performance. The Electronic Technician (ET) accesses stored diagnostic data, significantly reducing downtime. **pg. 8**

---

## Body Options

The 769D offers a flat floor or dual-slope option to meet specific user applications. Both incorporate time-proven box beam and full-length stringer design for extended life. A full offering of attachments and customized options are available to meet specific needs. **pg. 13**

---

## Operator Station

Controls and gauges are positioned to maximize productivity and comfort. The cab includes air suspension seat and advanced electronic monitoring system. Adjustable telescoping steering column, electric wipers, window and body controls reduce operator effort and simplify control. **pg. 14**

*Time proven iron and modern technology combine to provide a highly productive, durable, reliable off-highway truck, focused on our customers greatest need...lowest cost-per-ton.*





---

### Oil-Cooled, Rear Disc Brakes

Caterpillar oil-cooled, multiple disc brakes offer exceptional, fade-resistant braking and retarding. **pg. 10**

---

### Integrated Braking Control (IBC)

IBC integrates the optional Automatic Retarder Control and Traction Control System (TCS) into one system to enhance truck performance and productivity and improve operator confidence. **pg. 11**

---

### Structures

Caterpillar truck frames are built for severe applications. Mild steel provides flexibility, durability and resistance to impact loads. Castings and forgings in high stress areas of the frame provide great structural strength. **pg. 12**

---

### Serviceability/Total Customer Support

- ✓ Easy serviceability access, QuickEvac™ system, on- and off-board diagnostics, machine management service, worldwide parts availability and literature support represents the Caterpillar commitment to customer support. **pg. 16**

---

### Systems/Applications

Numerous options and a system approach to match the 769D to the most appropriate loader meets customer needs for various applications. **pg. 18**



✓ *New Feature*

## Power Train - Engine

*The eight cylinder, turbocharged and air-to-air aftercooled HEUI engine is built for power, reliability and economy with reduced sound levels and low emissions.*

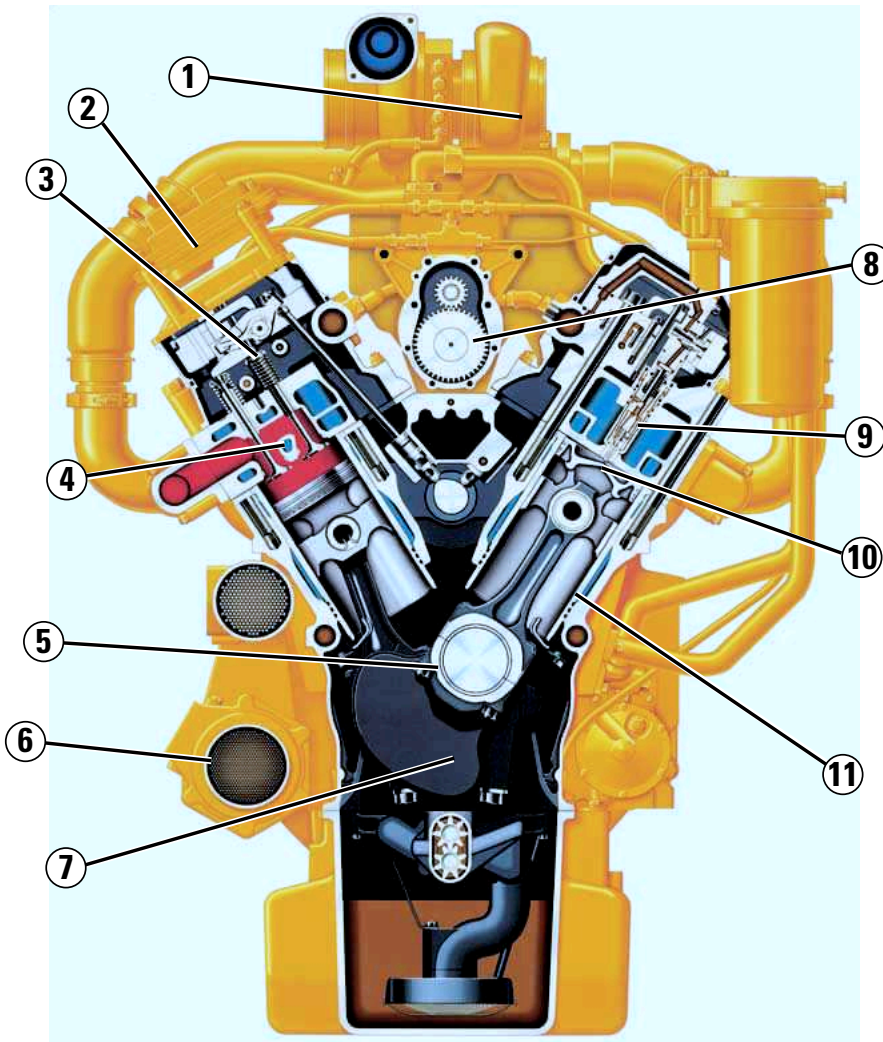

**Cat 3408E Diesel Engine.** The four-stroke design uses long power strokes for more complete fuel combustion and optimum efficiency. Large displacement and a low speed rating can help extend engine life. This engine meets U.S. Environmental Protection Agency Tier 2 emissions regulations and Stage II EU Emissions Directive 97/68/EC.

**Torque Rise.** The 27 percent torque rise provides high lugging force during acceleration on grade or in high rimpull conditions. The torque rise effectively matches the transmission shift points to provide maximum efficiency and faster cycle times.

### Engine.

- 1) Turbocharger
- 2) Electronic Control Module (ECM)
- 3) Valve Rotators
- 4) Stellite-Faced Valves
- 5) Steel-Backed, Copper-Bonded Bearings
- 6) Oil Cooler
- 7) Forged Crankshaft
- 8) Adjustment-Free Fuel Injection Pump
- 9) Hydraulic Electronic Unit Injectors
- 10) Forged Steel Pistons
- 11) Full-Length, Water-Cooled Cylinder Liners

**Engine Features.** Contributing to the 3408E power and reliability are:

- High pressure injection
- Full electronic control, one piece forged steel pistons with three rings cooled by oil spray
- Copper-bonded crankshaft bearings
- Hardened crankshaft journals
- Dry-type radial seal air cleaners with primary and secondary elements and precleaner
- Direct-electric, 24-volt starting system with 50-amp alternator and four 172-amp-hour, low maintenance, high output, 12-volt batteries



### Hydraulic Electronic Unit Injector (HEUI).

The HEUI is a proven high-pressure, direct injection fuel system. This system electronically monitors operator and machine inputs to optimize engine performance. HEUI is unique in its ability to independently control injection pressure over the entire engine operating range. This allows complete control over injection timing, duration, performance and efficiency. Rate shaping technology modifies the heat release characteristics of the combustion process for significant decreases in sound and emission levels. Exhaust smoke is significantly reduced through precise, electronic control of fueling limits and injection timing of the HEUI.



### Electronic Control Module (ECM).

The ECM monitors key functions and logs critical indicators. The Electronic Technician can access this diagnostic information for easier maintenance and repair.

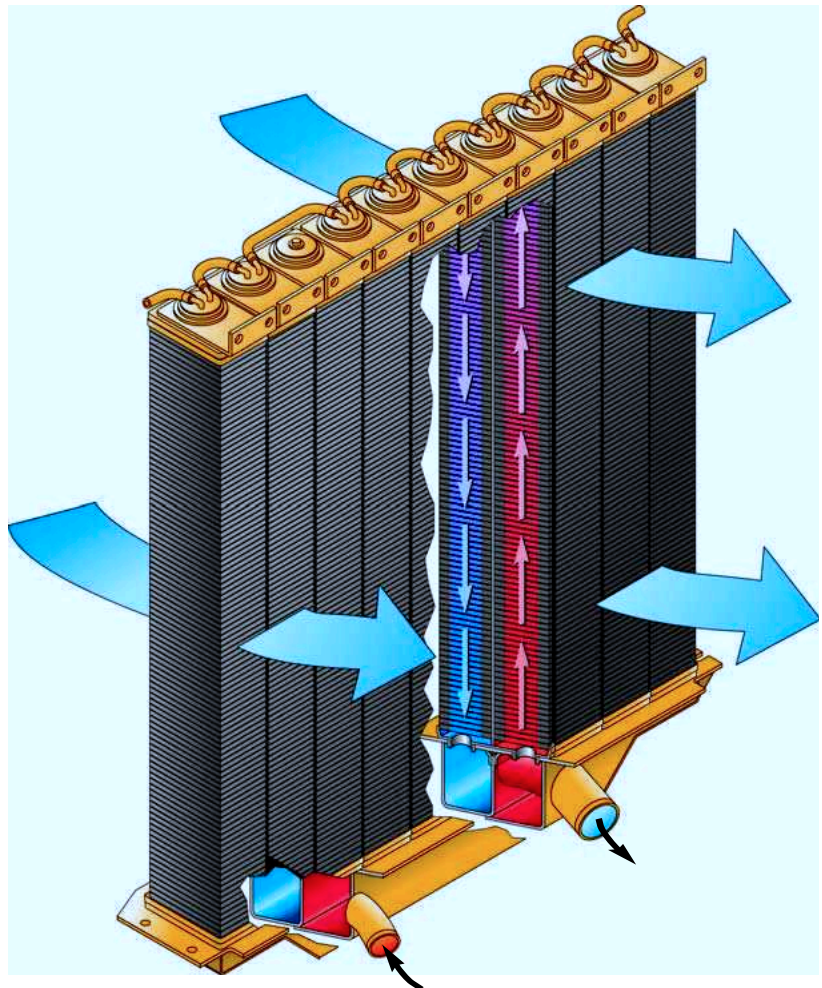

**Advanced Modular Cooling System (AMOCs).** Is a Caterpillar exclusive technology which improves serviceability and reduces downtime. It utilizes an exclusive two pass cooling system and increased cooling surface area to provide significantly more cooling capacity than conventional systems.

**System Operation.** The two pass system circulates coolant from the sectioned bottom tank up through one side of the cooling element and down through the other side returning it to the bottom tank.

**AMOCs Design.** The cooling elements are individual core modules, with brass tube construction within each core, that are connected to a sectioned bottom tank. There is no top tank to remove. Each core module can be replaced individually (without removing the entire radiator), saving considerable cost and repair time. And with nine steel fins per inch, fin bending resistance is improved.

## Power Train - Transmission

*The Cat seven-speed, power shift transmission gets the job done smoothly and quickly.*

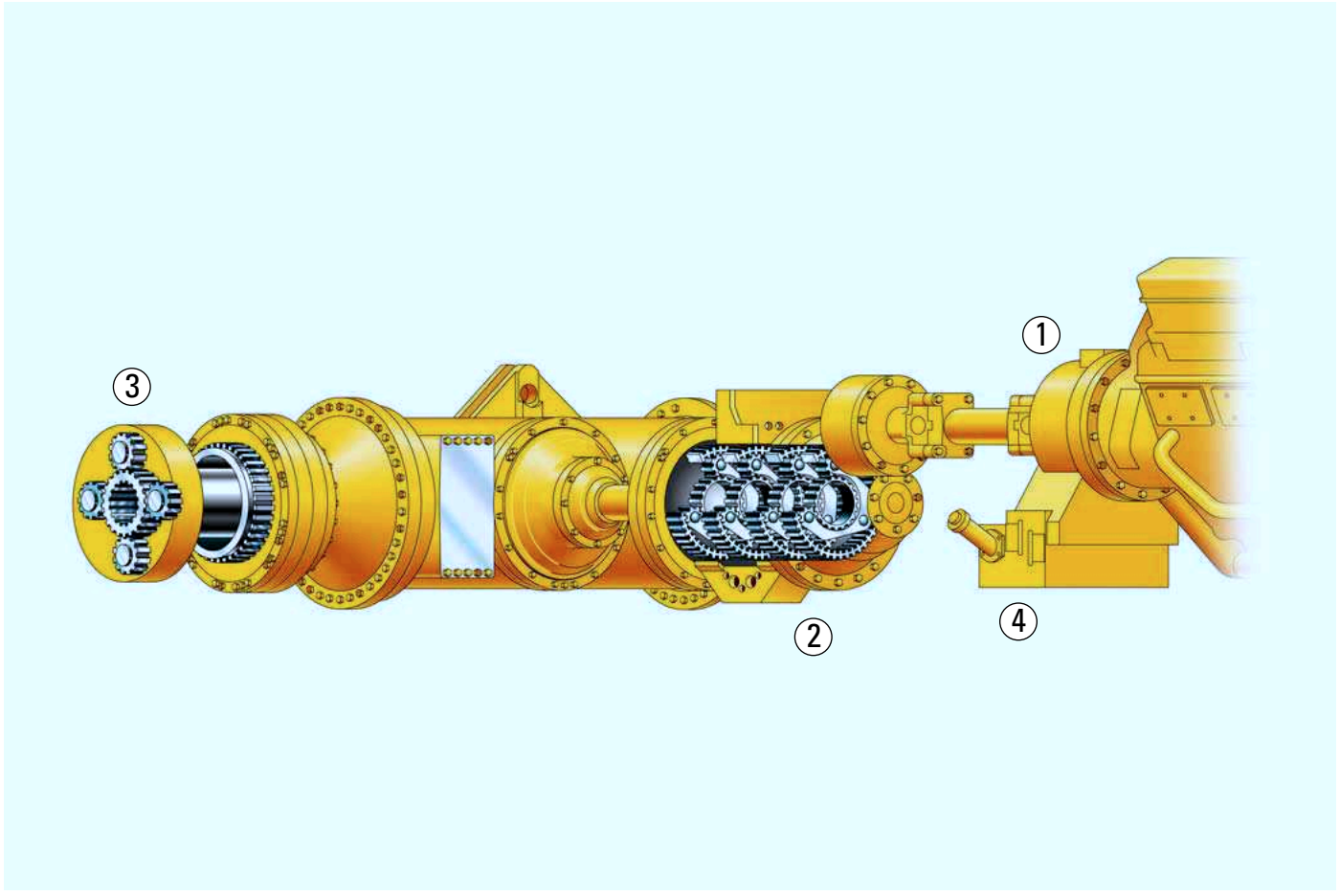

**Transmission.** The Cat seven-speed, power shift transmission, matched with the direct-injection 3408E diesel engine provides constant power over a wide range of operating speeds.

**Transmission Features.** Include:

- Seven speeds forward, one reverse
- Torque converter driven reverse
- First gear has both torque converter drive and direct drive
- Second through seventh gears are direct drive
- Single-lever shift control provides automatic shifting in all gears up to the one selected by the control lever
- Each shift is individually modulated for maximum smoothness
- Separate hydraulic circuit with cooler
- Electronic control has built-in diagnostics and fault code memory, event memory and programmable features
- Control throttle shifting
- Economy shift mode

**1) Lock-up Torque Converter.** Combines the maximum rimpull and cushioned shifting of torque converter drive with the efficiency and performance of direct drive.

- Engages at approximately 6.9 km/h (4.3 mph), delivering more power to the wheels.
- Lock-up clutch quickly releases and re-engages during shifts, maintaining power wind-up, improving transmission life and increasing operator comfort.

**2) Planetary Power Shift Transmission.** Utilizes a modulating pressure valve to regulate clutch pressure rise and fall to ease clutch engagement. This reduces shock loads on power train components. Features include:

- Large diameter clutches and robust planetary gears and bearings.

- Patented rotating clutch pressure seals minimize drag losses and improve reliability.

- 35 percent gear splits between all gears match Cat engine design for optimum use of engine power with minimized shifting and torque converter use.

**3) Final Drive.** Final drive and differential torque multiplication of 13.15:1 further reduces stress on the drive train.

**4) Sump.** Transmission and torque converter share a common sump. The combined sump offers an easily accessible fill tube and sight gauges.

**Axles.** Full floating axles are shot-peened to relieve internal stresses and increase durability. Rolled splines also provide increased service life.

**Wheels and Rims.** Cast rear wheels and Cat center-mount rims are mounted using studs and nuts to minimize maintenance and maximize durability.

**Transmission Chassis Controller (TCC).** TCC uses electronically transferred engine rpm data to execute shifts at preset points for optimum performance and efficiency. This integration allows:

- Programmable top gear limit
- Control throttle shifting
- Directional shift management
- Neutral coast inhibitor
- Economy shift mode

**Integration.** The Caterpillar power train integration provides increased component life and operator comfort.

## Engine/Power Train Integration

Combining the electronic Engine Control Module (ECM) with the Caterpillar Transmission Chassis Controller (TCC) allows critical power train components to work more intelligently.

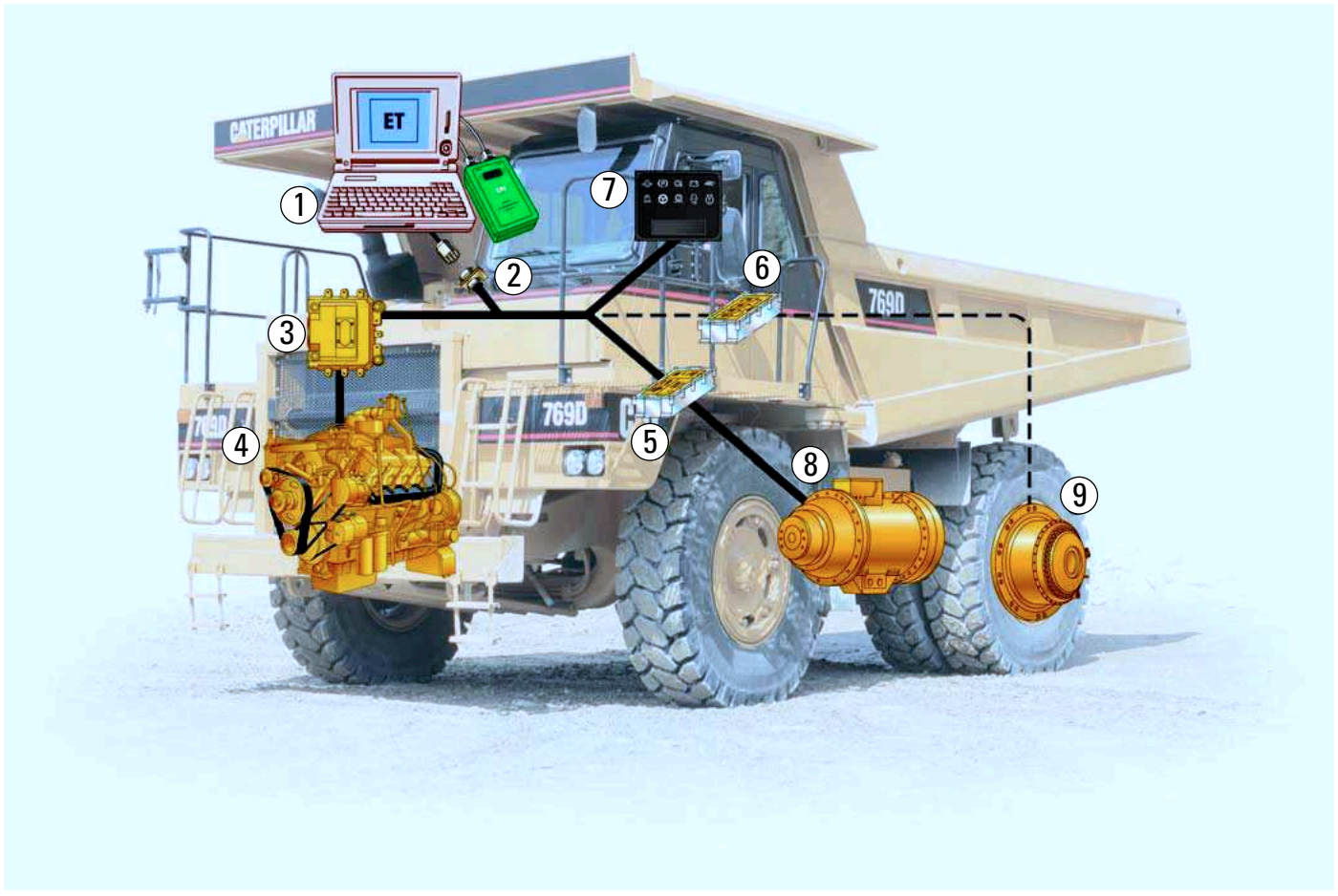

### Integration.

- 1) Electronic Technician
- 2) Cat Data Link System
- 3) Engine Control Module
- 4) Engine
- 5) Transmission Chassis Control
- 6) Automatic Retarder Control, Traction Control System and Integrated Brake Controller

7) Caterpillar Electronic Monitoring System

8) Transmission

9) Oil-cooled Brakes

**Cat Data Link.** The Cat Data Link electronically integrates the machine's computer systems, which allows communications and provides the following benefits:

- **Controlled Throttle Shifting.** Engine rpm is regulated during a shift to reduce driveline stress for smoother shifts and longer component life.
- **Economy Shift Mode.** Modifies engine maps, resulting in improved fuel consumption.



• **Directional Shift Management.**

Regulates engine speed during directional shifts to prevent damage caused by high speed directional changes.

**Elevated Idle Neutral Coast Inhibitor.**

Helps prevent the transmission from shifting to neutral at speeds above 6.5 km/h (4 mph).

**Body-up Shift Inhibitor.** Helps prevent the transmission from shifting above a pre-programmed gear without the body fully lowered.

**Event Memory.** Records machine management data that can be accessed using the Electronic Technician. Recorded information includes:

- Shift histograms
- Operator-induced events
- Lock-up clutch counter
- Machine overspeed
- Transmission overspeed

**Electronic Technician (ET).** The electronic engine and transmission controls provide exhaustive diagnostic capability for service technicians. The ability to store both active and intermittent indicators will simplify problem diagnosis and total repair time, resulting in improved mechanical availability and lower operating cost.

ET accesses data stored in the engine and transmission controls via the Cat Data Link System.

ET displays the status of all engine parameters including throttle position, timing and fuel flow.

ET replaces 13 mechanical tools to perform functions like cylinder cutout checks, injector solenoid tests and timing calibration.

**Caterpillar Electronic Monitoring System (CEMS).** CEMS allows the operator to view requested information and utilizes a three-category warning system to alert the operator to abnormal machine conditions.

**Optional Attachments.** Caterpillar offers optional attachments that integrate with the Cat Data Link System.

• **Automatic Retarder Control (ARC).**

Works with other electronic components to automatically control retarding on grade, maintaining approximately 2,230 rpm.

• **Traction Control System (TCS).**

Improves performance in poor underfoot conditions by electronically monitoring and controlling wheel slippage.

• **Integrated Brake Controller (IBC).**

Combines ARC and TCS, reducing the number of electronic components and electrical lines.

## Oil-Cooled, Rear Disc Brakes

Rear braking lets the operator concentrate on the haul road.

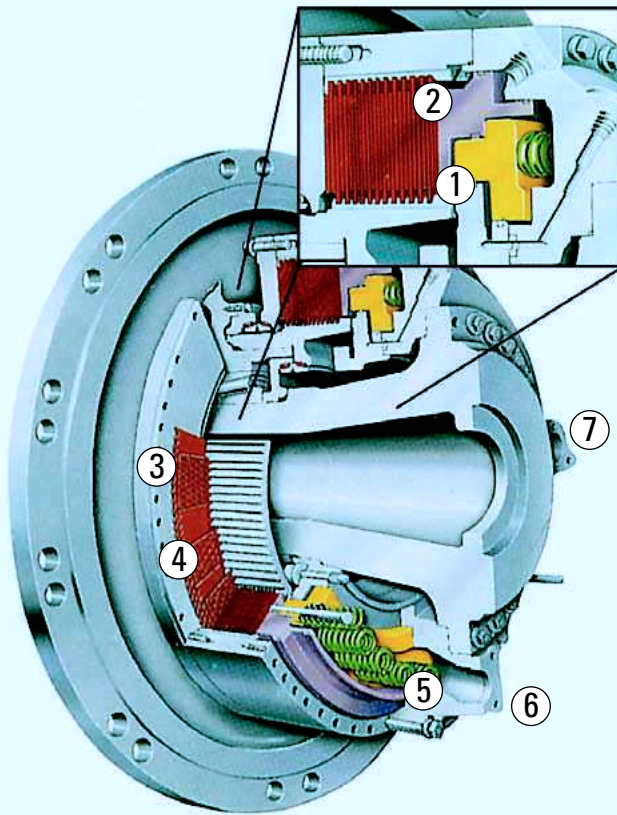

### Brakes.

- 1) Parking/Secondary Piston
- 2) Service/Retarding Piston
- 3) Friction Discs
- 4) Steel Plates
- 5) Actuating Springs
- 6) Cooling Oil In
- 7) Cooling Oil Out

**Multiple Disc Brakes.** Caterpillar forced oil-cooled, multiple disc brakes are continuously cooled for exceptional, fade-resistant braking and retarding. The optional ARC and TCS utilize the oil-cooled rear brakes to enhance truck performance and increase productivity.

**Oil Cooled Disc Brakes.** Are designed and built for reliable, adjustment-free operation providing superior performance and service life in comparison to shoe-type and dry-disc systems.

**Oil Film.** An oil film prevents direct contact between the discs. Absorbing the braking forces by shearing oil and carrying heat away, this design extends brake life.

**Secondary Braking.** Spring applied, hydraulically released, oil-cooled disc brakes are located on the rear axle. The front brakes will activate as part of the secondary system, even if switched out of service.

**Parking Brakes.** Spring applied, hydraulically released parking brakes use wet disc brakes in service system. A toggle switch activates the parking brakes.

**Pistons.** A Caterpillar patented, two-piston design combines the service, secondary and parking brakes, along with retarding functions.

The primary piston hydraulically actuates both service and retarding functions.

The secondary piston is spring-applied and held in the disengaged position by hydraulic pressure. If hydraulic system pressure drops below a certain level, the spring-applied secondary piston automatically applies the brakes.

# Integrated Braking Control (IBC)

*Electronically combines Automatic Retarding Control (ARC) and the Traction Control System (TCS) into one integrated control system.*

**Cat Retarding System.** When retarding, the engine runs against compression on downhill hauls, resulting in no fuel burn.

Retarding forces and heat are absorbed through the oil. The retarding system generates lower drive line stresses than drive line retarding systems.

## ARC Operating Efficiency Advantages

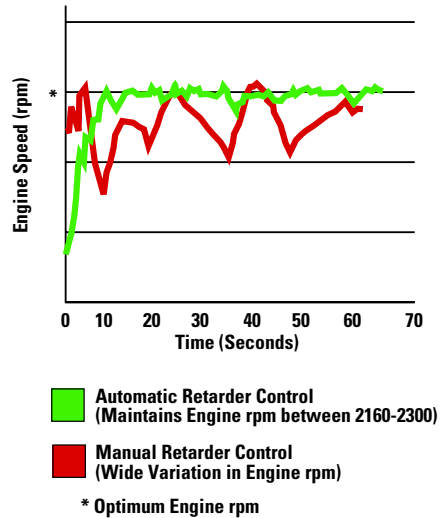

### Automatic Retarder Control (Optional).

The ARC electronically controls braking on grade to maintain approximately 2,230 engine rpm (engine rpm is adjustable from 2,160-2,300 rpm in increments of 10 rpm). ARC is deactivated when the operator applies the brakes or throttle.

**Engine Overspeed Protection.** With the accelerator depressed and/or ARC turned off, ARC will automatically activate at 2,475 rpm to help avoid potentially destructive and often costly engine overspeeds.

**ARC Benefits.** Include:

- Increased operating efficiency with faster downhill speeds. By maintaining consistently higher engine speeds, average truck speed will be higher than a manually controlled truck.
- Excellent controllability and reduced operator effort. Automatic brake modulation provides a smoother ride over manual modulation, allowing the operator to focus more on truck operation down the haul road.
- Improved component life, optimized system cooling capability and reduced torque fluctuations result from ARC's precision.
- Faster troubleshooting and diagnosis with self-diagnostic capability and the ability to communicate with ET through the Cat Data Link System.
- Operator awareness through electronic integration and CEMS, alerting the operator to overspeed conditions and critical machine functions.

### Traction Control System (Optional).

Monitors wheel slip so if it exceeds the set limit, the oil-cooled disc brakes are automatically applied to slow the spinning wheel.

**Operator Awareness.** An on-dash indicator shows the operator that TCS is engaged.

**Differential Action.** Utilizes normal differential action to provide superior maneuvering in poor underfoot conditions. Also reduces tire scuffing as compared to positive lock differentials used on other systems.

**Torque.** TCS divides torque equally to reduce stress created on final drives and axles when torque is transferred to one side.

**System Back-up.** Should sensors fail, the normal differential action is still available to maintain control and steering.



## Structures

*The backbone of the Cat off-highway truck.*

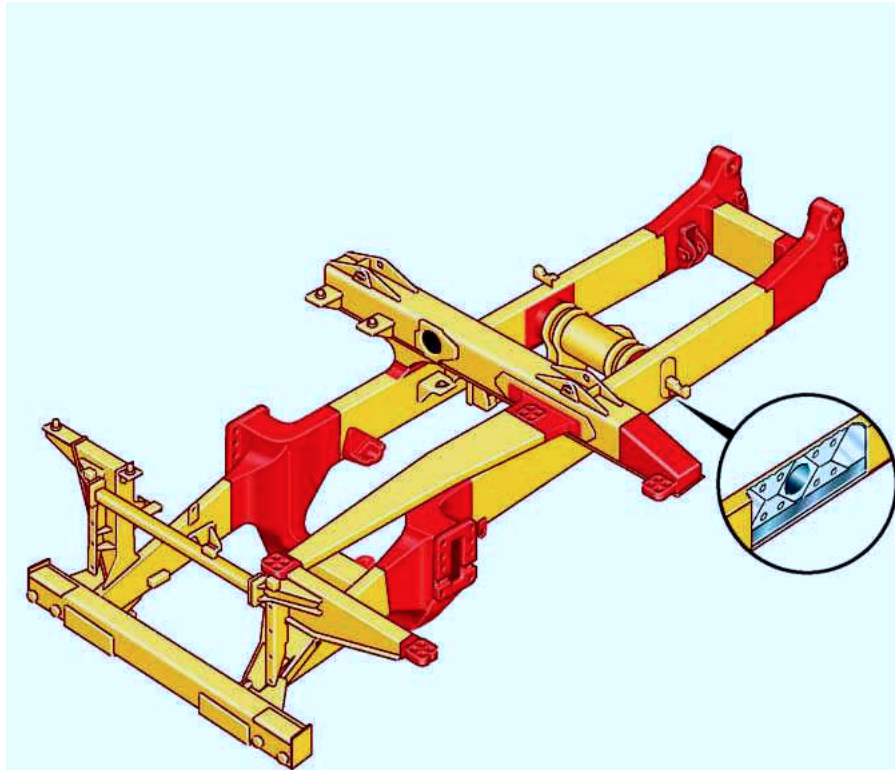

**Box-Section Design.** The 769D frame uses a box section design, incorporating 17 castings in high stress areas with deep penetrating and continuous wrap-around welding. Mild steel, which provides flexibility, durability and resistance to impact loads even in cold climates is used throughout.

**Castings.** Castings have large radii with internal reinforcing ribs to dissipate stress. Castings move welds to lower stress areas and provide two to three times the strength of equivalent sized fabricated structures.

**Frame Features.** Include:

- Integral front bumper
- Front box beams for suspension cylinder and ROPS support
- Box-section rear crossmember for body and ROPS support with attachment points for maintenance platform and rear engine hood hinge support
- Castings are used to provide additional strength in critical stress areas
- Mild steel plates (290 MPa [42,000 psi] minimum yield strength) and castings (241 MPa [35,000 psi] minimum yield strength) provide flexibility, durability and easy field maintenance

**Frame Serviceability.** The box-section frame allows simple access to power train components. This open design reduces overall removal and installation time, lowering repair costs. Transmission access is excellent under the raised and pinned body. Repairs can be made without preheating in ambient temperatures 16° C (60° F) using readily available welding supplies.

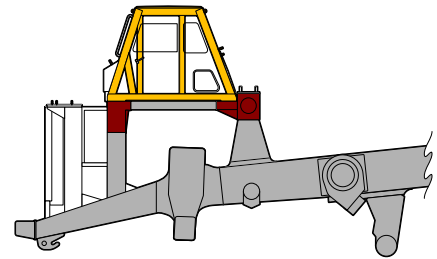

**Rollover Protection Structure (ROPS).**

The ROPS attaches securely to four castings welded into the frame.

**Suspension System.** Designed to dissipate haul road and loading impacts for extended frame life.

Four, independent, self-contained, oil pneumatic, variable-rebound, suspension cylinders absorb shocks. Rear cylinders allow axle oscillation and absorb the bending and twisting stresses. Front cylinders, mounted to the frame, serve as steering kingpins, providing excellent maneuverability and reduced maintenance. Caster and camber are preset.

## Body Options

Caterpillar builds a variety of rugged, durable bodies to perform in the toughest applications.

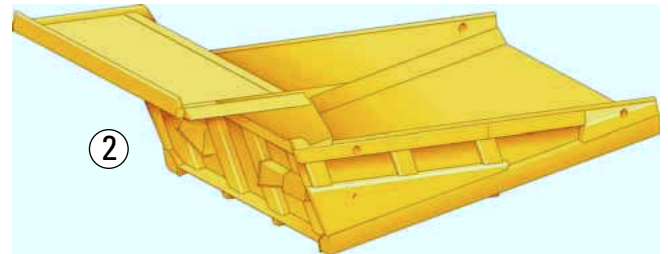
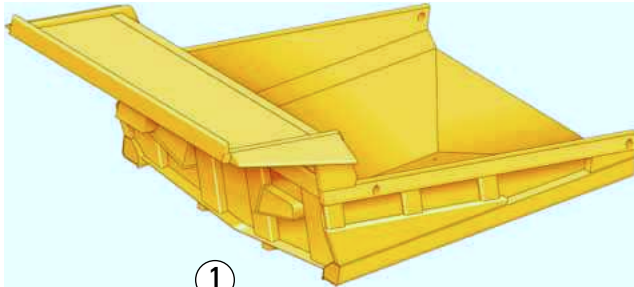

**Design.** 769D bodies are designed to handle a variety of material densities. Maximum payload is reached in three to five passes from a matched Cat loader in  $1700 \text{ kg/m}^3$  ( $2,900 \text{ lb/yd}^3$ ) material and higher.

**Sidewall and Floor Junctions.** Are joined by five-sided beams to resist impact loading and sustained hauling stresses.

**Box-Section Beams.** Offer increased durability in the floor, sidewalls, top rail, corner and cab canopy areas.

**400 Brinell Steel.** Wear surfaces provide excellent wear resistance and are easily welded without preheating procedures.

**Two-Stage Hoist Cylinders.** Provide fast dump cycle times of 7.5 seconds for Raise and 8.3 seconds for Lower.

**Standard Body.** Comes exhaust heated with options including a full-time muffler or exhaust diverter.

**Custom Attachments.** Including tail extensions, liner packages, sideboards and other custom designs are offered to help ensure rated payload.

**1) Dual-Slope Body.** Offers the lowest cost-per-ton option in most construction and mining applications.

**Dual-Slope Body Performance.** Efficient under most haul road conditions, but its strength comes from higher levels of production in sites with rough haul roads and steeper grades.

**Body Floor Construction.** Uses an eight degree "V" bottom for increased load retention, a low center of gravity and reduced shock loading. It also aids in centering the load.

**An 18 Degree Ducktail and 9 Degree Forward Body Slope.** Retains the load on grades up to 15 percent and higher. This design also helps maintain proper load distribution.

**2) Flat Floor Construction and Mining Body.** Offers excellent load retention on grades up to 12 percent and on smoother haul road conditions.

**Body Floor Construction.** Uses a 12 degree single slope, offering excellent wear characteristics and uniform dumping into hoppers, crushers and feeders.

## Operator Station

*Control ease and comfort maximize productivity.*

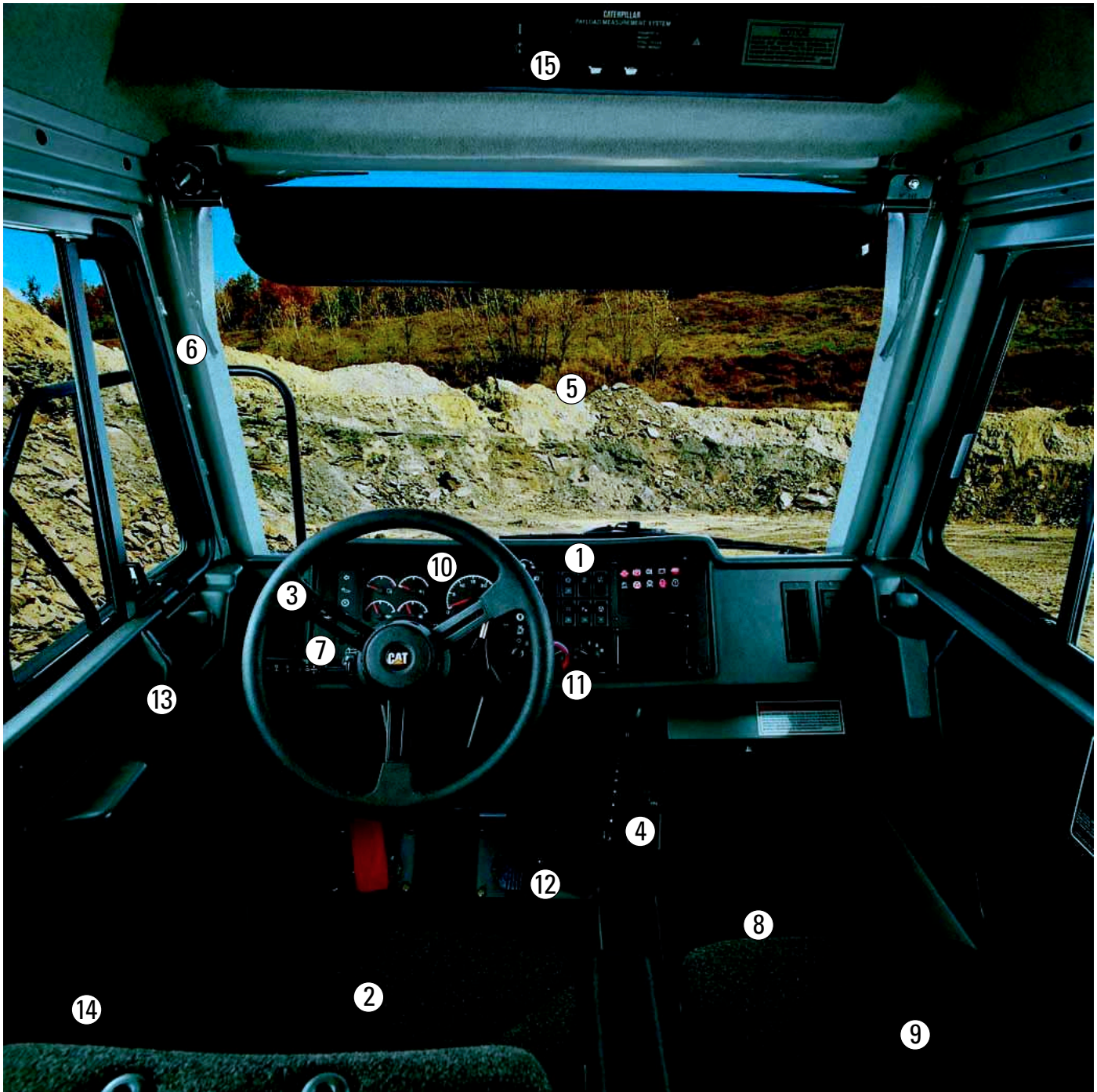



**769D Operator Station.** Rated highly by operators. Everything needed for top performance is at the operator's fingertips.

**1) Wraparound Dash Panel.** Offers an easy line-of-sight arrangement, using LED backlit rocker switches.

**2) Caterpillar Contour Series Air Suspension Seat.** Standard and fully adjustable, including an adjustable right-hand armrest.

**3) Tilt/Telescoping Steering Wheel.** With ergonomic grip improves comfort and control. Low effort steering system and ergonomically designed retarder lever reduces operator fatigue. Also includes an enhanced turn signal lever with high beam actuator and electric windshield wiper controls.

**4) Transmission Console.** Has LED backlit gear numbers and ergonomic shift knob.

**5) Visibility.** Exceptional all-around viewing area reduces fatigue and improves productivity.

**6) Integral, Sound-Suppressed ROPS/FOPS Cab.** Is resiliently mounted providing a quiet, protected work environment. The cab is radio-ready with speakers, wiring harness, antenna and mounting bracket.

**7) Front Brake Cut-Out Switch.** Increases front brake component life.

**8) Large Storage Compartment.** 0.10 m<sup>3</sup> (3.5 ft<sup>3</sup>) of space is located under the trainer's seat.

**9) Trainer's Seat.** Includes back rest and retractable seat belt.

**10) Caterpillar Electronic Monitoring System (CEMS).** Provides critical data. The system features three separate displays:

- Four-gauge cluster with coolant temperature, oil temperature, brake air pressure, fuel level
- Tachometer, digital speedometer/ actual gear indicator
- Message center module

**11) Standard Heater and Optional Air Conditioner.** Includes four-speed fan and nine vents.

**12) Foot Pedals.** Ergonomically designed for increased operator comfort.

**13) Electric Power Window.** For simplified operation.



**14) Electrohydraulic Hoist Lever.** Is fingertip actuated and provides low impact body-down snubbing.



**15) Truck Production Management System (TPMS) (Optional).** Provides payload and cycle time data.

- Cat developed technology utilizes strut pressure sensors and an on-board microprocessor to determine payload weight.
- Accurate under normal loading to within  $\pm$  five percent over a normal operating shift.
- Delivers consistent accurate payloads and improves efficiency by minimizing overloading and underloading
  - On-board computer stores 1,400 cycles for further analysis of payload weight, cycle segment times, cycle segment distances and actual clock time and date of each cycle.
  - External lights signal loading tool operator when payload is reached.
  - Internal troubleshooting and fault recording for easier maintenance.

## Serviceability/Total Customer Support

*Purchase of a Caterpillar machine includes a total commitment to customer support.*

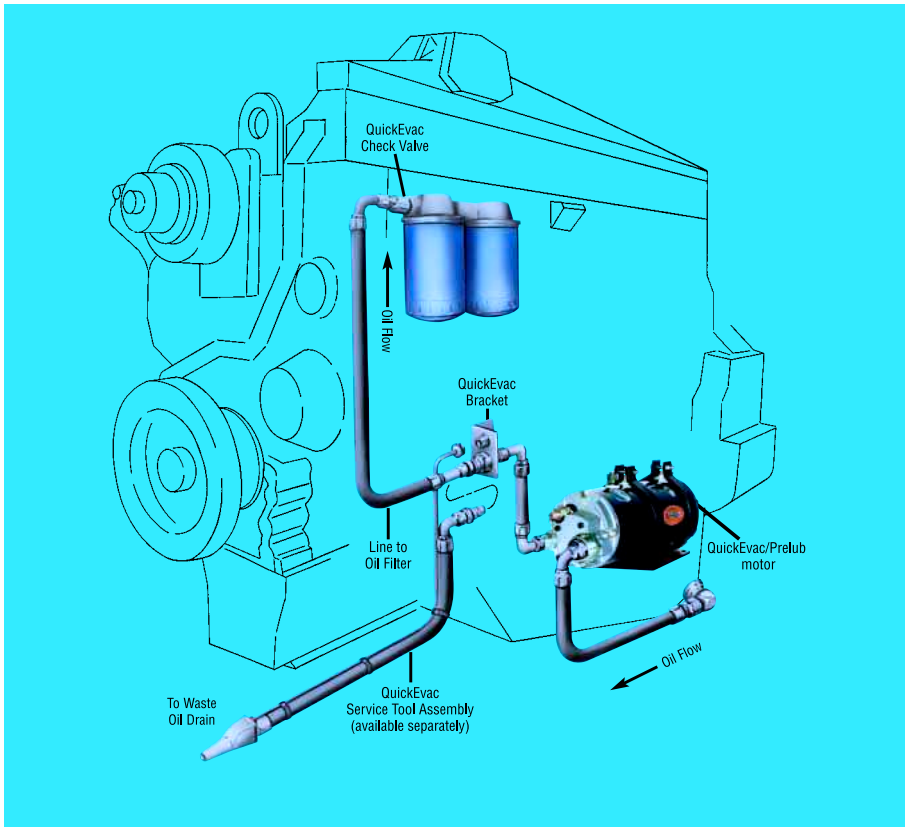

**Cat QuickEvac™ System.** Is an exclusive Caterpillar on-board engine oil evacuation and prelubrication system.

**Automated Engine Oil Change.** A new, state of the art, on-board system evacuates engine sump in less than two minutes and allows for partial purge of oil filters prior to removal, minimizing oil spills. New oil is delivered through primary filters, enhancing contamination control efforts while ensuring that new filters are correctly filled following routine oil change.

**Contamination Control.** Environmentally efficient, clean oil changes are ensured since engine sump is evacuated directly into PM trucks or waste containers with flush faced, quick disconnects for fast evacuation and fill. This eliminates handling of waste oil, minimizes chances of oil spillage and enhances contamination control efforts by ensuring complete filtration of new oil on engine refill.

### **Complete Engine Prelubrication.**

Provides engine oil pressure prior to engine cranking. Reduces engine dry start wear and risk of cold starts for increased protection of key components. Also provides expanded low temperature range for 15W40 motor oils.

**Improved Serviceability and Machine Availability.** Reduces time to complete engine service (changing engine oil, oil filters, fuel filter, air cleaner) by as much as 30 to 50 percent. Improves the ability to better schedule engine services at prescribed hours, and integrates easily with PM trucks to further reduce total cycle time of engine service.

**Maintenance Platform.** Provides access to air tanks, brake master cylinder and make-up tank; engine oil level; air filters; steering hydraulic tank; and battery compartment.



**Ground Level Battery Disconnect Switch.** Facilitates safe, convenient servicing and maintenance.

**On-Board Diagnostics.** With CEMS, provides the machine operator with a three-category warning system and quick access to stored diagnostic data.

**Off-Board Diagnostics.** With ET, allows service technicians access to stored diagnostics data reducing downtime and lowering operating costs. ET stores engine parameter information such as timing, throttle position and fuel flow. Transmission data is available through ET via access to the Cat Data Link System.

**Radial Seal Filters.** Are easy to change, reducing air filter maintenance times.

**Vertical, Spin-on Oil Filters.** Provide for simplified servicing.

**Quick Coupler Pressure Taps.** Located in all hydraulic systems provide clear, quick pressure checks. S-O-S<sup>SM</sup> oil analysis points make oil sampling quick, clean and easy.

**Sealed Electrical Connectors.** Lockout dust and moisture. Color-coded wiring is standard for the entire Cat product line.

**Machine Management Service.** Cat Dealers help manage equipment investments with:

- Vehicle systems analysis to help match the right machine to the job
- Preventative maintenance programs
- S-O-S oil analysis and technical analysis programs
- Repair option analysis
- Training for operators and mechanics
- TPMS data analysis

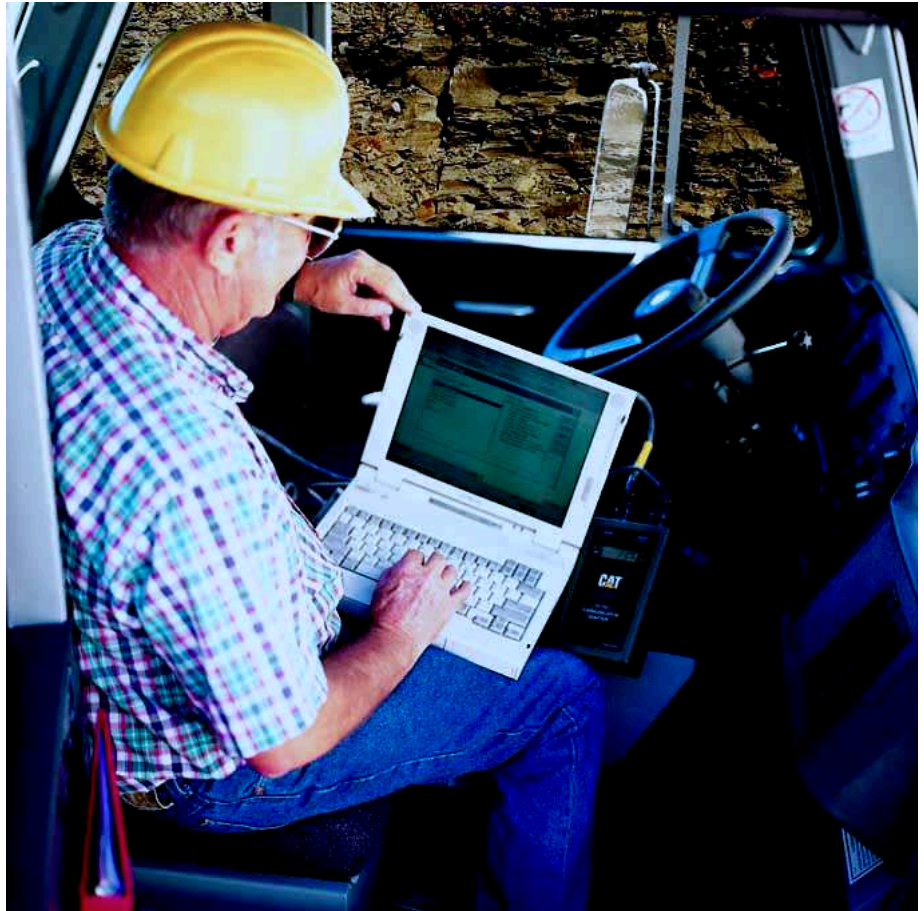

**Parts Availability.** The Caterpillar worldwide computer network locates parts instantly to minimize machine downtime.

**Literature Support.** Caterpillar manuals are easy to use and help provide the full value of an equipment investment.



## Systems/Applications

*The 769D is designed for versatility.*



### **Machine Configuration Options.**

Caterpillar offers a variety of machine configuration options to help meet customer needs.

**Body Options.** Include a full line of standard and custom designs based on specific customer preference, material density, loading tool and site conditions.

**Tire Options.** A full line of tire options, representing various manufacturers, is offered by Caterpillar to maximize performance and life for specific applications.

**Attachments.** Give the customer options to tailor trucks for specific application requirements, including:

- Truck Production Management System
- Automatic Retarder Control
- Traction Control System
- Custom product offerings
- Muffler/exhaust diverter

**System Approach.** The Caterpillar system approach means increased efficiencies through common design. Haul trucks, loaders, excavators, tractors, engines for generator sets and pumps - all designed by Caterpillar - use common components, parts and design. Commonality reduces customer parts stock, improves parts availability, reduces training/maintenance and improves diagnostics. This system approach adds up to lower cost-per-ton. Dealer support is available to address customer needs regardless of the component.

### **Caterpillar Product Analysis Team**

**(PAT).** Combined with Caterpillar software programs can assist customers with detailed, application evaluation.

**Loader Match.** Designed to work as part of a system, the 769D is best matched to the following Caterpillar loaders:

- 980G - four to five pass/match
- 988G - three to four pass/match
- 5080 - four to five pass/match
- 375ME - four to five pass/match

## Engine

Engine Model	Cat 3408E	
Gross Power	386 kW	518 hp
Flywheel Power	363 kW	487 hp
DIN 70020	505 PS	
Max. Torque	2194 N.m	1,618 lb ft
Torque rise	27 %	
Bore	137 mm	5.4 in
Stroke	152 mm	6 in
Displacement	18 L	1,099 in <sup>3</sup>

- Gross power meets ISO 3046-02 standards.
- Flywheel power meets ISO 9249, SAE J1349 JUN 95 and EEC 80/1269 standards.
- These ratings apply at 2,000 rpm when tested under the specified standard conditions for the specified standard.
- Power rating conditions based on standard air conditions of 25° C (77° F) and 99 kPa (29.32 in Hg) dry barometer, using 35° C API gravity fuel having an LHV of 42 780 kJ/kg (18,390 Btu/lb) when used at 30° C (86° F) [reference a fuel density of 838.9 g/L (7.001 lb/gal)].
- Net power advertised is the power available at the flywheel when the engine is equipped with fan, air cleaner, muffler and alternator.
- No derating required up to 3050 m (10,000 ft) altitude.
- Meets U.S. Environmental Protection Agency Tier 2 emissions regulations.
- Meets Stage II EU Emissions Directive 97/68/EC.

## Transmission

Forward 1	12.6 kph	7.8 mph
Forward 2	17.2 kph	10.7 mph
Forward 3	23.3 kph	14.5 mph
Forward 4	31.4 kph	19.5 mph
Forward 5	42.5 kph	26.4 mph
Forward 6	57.3 kph	35.6 mph
Forward 7	77.7 kph	48.3 mph
Reverse	16.6 kph	10.3 mph

- Maximum travel speeds (standard 18.00-R33).

## Brakes

Brake surface - front	1395 cm <sup>2</sup>	216 in <sup>2</sup>
Brake surface - rear	54 999 cm <sup>2</sup>	8,525 in <sup>2</sup>
Differential ratio	2.74:1	
Planetary ratio	4.80:1	
Total reduction ratio	13.15:1	

- Brakes meet the SAE J/ISO 3450:1998, ISO 3450:1996 standards up to 71 400 kg (157,000 lb) gross operating weight.

## Service Refill Capacities

Fuel Tank	530 L	140 gal
Cooling System	113.5 L	30 gal
Crankcase	45 L	12 gal
Differentials and final drives	83 L	22 gal
Steering tank	34 L	9 gal
Steering system (includes tank)	56 L	15 gal
Brake/hoist hydraulic tank	155 L	35 gal
Brake/hoist system (includes tank)	277 L	73 gal
Torque converter/transmission sump	53 L	14 gal
Torque converter/transmission system (includes sump)	72 L	19 gal

## Body Hoists

Pump flow - high idle	417 L/min	110 gal/min
Relief valve setting - raise	17 225 kPa	2,500 psi
Relief valve setting - lower	3445 kPa	500 psi
Body raise time @ high idle	7.5 Seconds	
Body lower time float	8.3 Seconds	
Body power down @ high idle	8.3 Seconds	

- Twin, two-stage, hydraulic cylinders mounted inside the main frame, double acting in second stage.
- Power raise in both stages and power down in second stage.

## Suspension

Effective cylinder stroke - front	234 mm	9.2 in
Effective cylinder stroke - rear	149 mm	5.9 in
Rear axle oscillation	±8.5°	

## Final Drives

Differential ratio	2.74:1
Planetary ratio	4.80:1
Total reduction ratio	13.15:1

- Planetary, full-floating.

## Approximate Weights - Flat Floor

Gross vehicle	71 400 kg	157,000 lb
Chassis	23 000 kg	50,600 lb
Body	7800 kg	17,200 lb
Standard liner	3300 kg	7,200 lb
Front axle - empty	49.7 %	
Front axle - loaded	33.3 %	
Rear axle - empty	50.3 %	
Rear axle - loaded	66.7 %	

- Percentages represent weight distribution without liner

## Approximate Weights - Dual-slope

Gross vehicle	71 400 kg	157,000 lb
Chassis	23 000 kg	50,600 lb
Body	7300 kg	16,200 lb
Standard liner	3200 kg	7,000 lb
Front axle - empty	49.8 %	
Front axle - loaded	33.3 %	
Rear axle - empty	50.2 %	
Rear axle - loaded	66.7 %	

## Weights

Gross Machine Weight	71 400 kg	157,000 lb
----------------------	-----------	------------

## Operating Specifications

SAE (2:1) Capacity	24.2 m <sup>3</sup>	31.7 yd <sup>3</sup>
Nominal Payload Capacity	36.4 tonnes	40.0 tons

- Refer to the Caterpillar 10/10/20 Payload Policy.

## ROPS

- ROPS Meets SAE J1040 MAY94 and ISO 3741:1994
- Rollover Protective Structure (ROPS) is offered by Caterpillar as standard equipment.
- The operator sound pressure level is less than 74 dB(A) when measured according to the stationary test procedures and the conditions specified in ISO 6394.
- The operator sound exposure Leq (equivalent sound pressure level) is less than 79 dB(A) when measured according to the work cycle procedures specified in ANSI/SAE J1166 MAY 90 for the cab offered by Caterpillar when properly installed and maintained and windows closed.

## Tires

- Tires Standard: 18.00-R33 (E4)
- Productive capabilities of the 769D are such that, under certain job conditions, TKPH (TMPH) capabilities of standard or optional tires could be exceeded and, therefore, limit production.
- Caterpillar recommends the user evaluate all job conditions and consult the tire manufacturer to make proper tire selection.

## Sound

- Exterior Sound Meets ISO, ANSI/SAE standards
- This machine, in standard configuration, when measured and operated per the prescribed modes in ANSI/SAE J88 APR95 has a 15 m sound pressure level of 84 dB(A) for the mode that gives the highest level.
- When the optional attachment sound suppression package is properly installed and maintained, this machine complies with the European Directive for Equipment Used Outdoors - 2000/14/EC.

## Steering

- Steering Meets SAE J1511 FEB94 and ISO 5010-1992
- Turning diameter per ISO 7457-1997 is 17.0 m (55 ft 9 in).
- Machine clearance diameter per ISO 7457-1997 (E) is 20.3 m (66 ft 7 in).
- Steering angle (left or right) is 39 degrees.
- Separate hydraulic system prevents cross contamination.
- Steering wheel effort is low and cycle times are reduced with dynamic, load sensing, variable displacement piston-type steering pump.



# Dimensions

All dimensions are approximate.

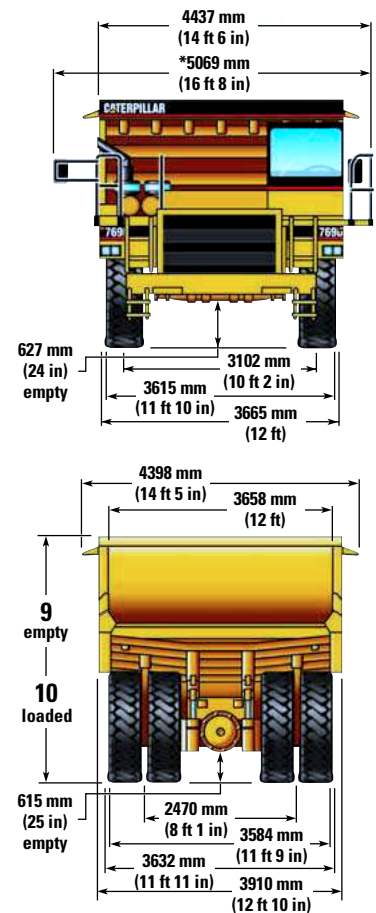
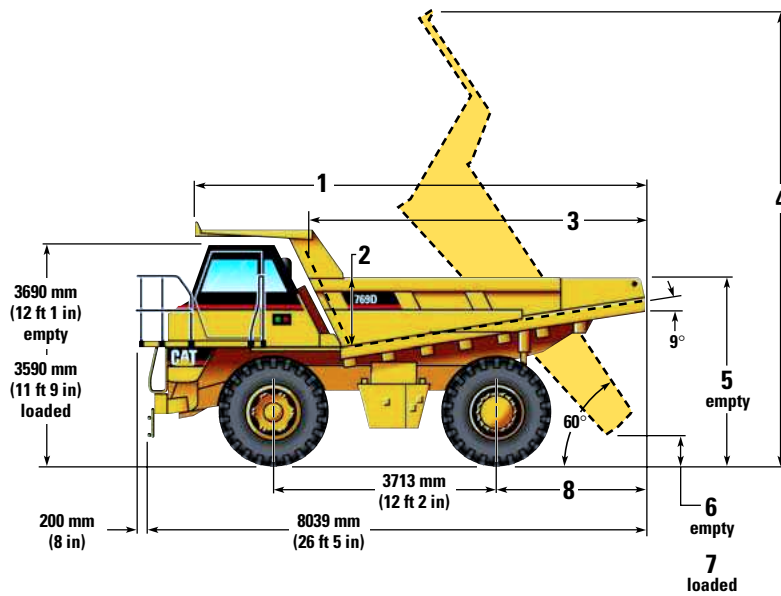

\* Operating width to r.h. mirror

	Flat Floor		Dual-slope	
1	7615 mm	25 ft 0 in	7430 mm	24 ft 5 in
2	1390 mm	4 ft 7 in	1454 mm	4 ft 9 in
3	5430 mm	17 ft 10 in	5275 mm	17 ft 4 in
4	7751 mm	25 ft 5 in	7709 mm	25 ft 4 in
5	3188 mm	10 ft 6 in	3143 mm	10 ft 4 in
6	465 mm	1 ft 6 in	525 mm	1 ft 9 in
7	315 mm	1 ft 0 in	415 mm	1 ft 4 in
8	2541 mm	8 ft 4 in	2380 mm	7 ft 10 in
9	4072 mm	13 ft 4 in	4027 mm	13 ft 3 in
10	3997 mm	13 ft 1 in	3952 mm	13 ft 0 in

## Capacity - Flat Floor - 100% fill factor

Struck	16.5 m <sup>3</sup>	21.6 yd <sup>3</sup>
Heaped 3:1	21.6 m <sup>3</sup>	28.3 yd <sup>3</sup>
Heaped 2:1 (SAE)	24.2 m <sup>3</sup>	31.7 yd <sup>3</sup>
Heaped 1:1	31.7 m <sup>3</sup>	41.5 yd <sup>3</sup>

## Capacity - Dual-slope - 100% fill factor

Struck	17 m <sup>3</sup>	22.2 yd <sup>3</sup>
Heaped 3:1	21.7 m <sup>3</sup>	28.4 yd <sup>3</sup>
Heaped 2:1 (SAE)	24.2 m <sup>3</sup>	31.7 yd <sup>3</sup>
Heaped 1:1	23.7 m <sup>3</sup>	31 yd <sup>3</sup>

# Retarding Performance

The brake performance retarding curves shown in this section are for general guidance only. As each site has many unique environmental and operating conditions that will impact retarding performance, actual site performance could vary considerably from predicted performance. Users should use the retarding speed (gear) recommendations from these tables as a starting point for determining retarding performance and then adjust retarding speeds to their site-specific conditions. In adjusting retarding performance to continuously changing environmental and site-specific conditions, users need to exercise care to maintain brake cooling and machine controllability at all times.

To determine brake retarding performance from retarding tables:

1. Determine the total distance of all downhill grades combined for a given haul profile. This total distance determines the appropriate retarding table (continuous or one of the grade distance tables) applicable to your haul profile.

2. Read from the appropriate gross weight down to percent favorable effective grade. (For these retarding charts, effective grade equals the maximum grade of all downhill haul segments minus rolling resistance – do not use an average grade value.)
3. From the intersection of the gross weight and effective grade line point, read horizontally to the appropriate gear curve. If the horizontal line intersects two gear curves, choose the first gear curve that the horizontal line intersects (reading from right to left) and read the retarding speed performance immediately below this point. If the intersection point falls on a vertical line between two gears, choose the lowest of the two gears to allow for higher engine rpm thus maximizing brake cooling capability.
4. Adjust recommended retarding speeds to site specific (environmental and operational) conditions. If the brake system overheats or specific site conditions dictate (tight turns, short steep grades, manual braking, etc.), reduce ground speed to allow the transmission to shift to the next lower speed range.

- — — — — Empty Weight
- - - - - Gross Machine Weight  
71 400 kg (157,000 lb)

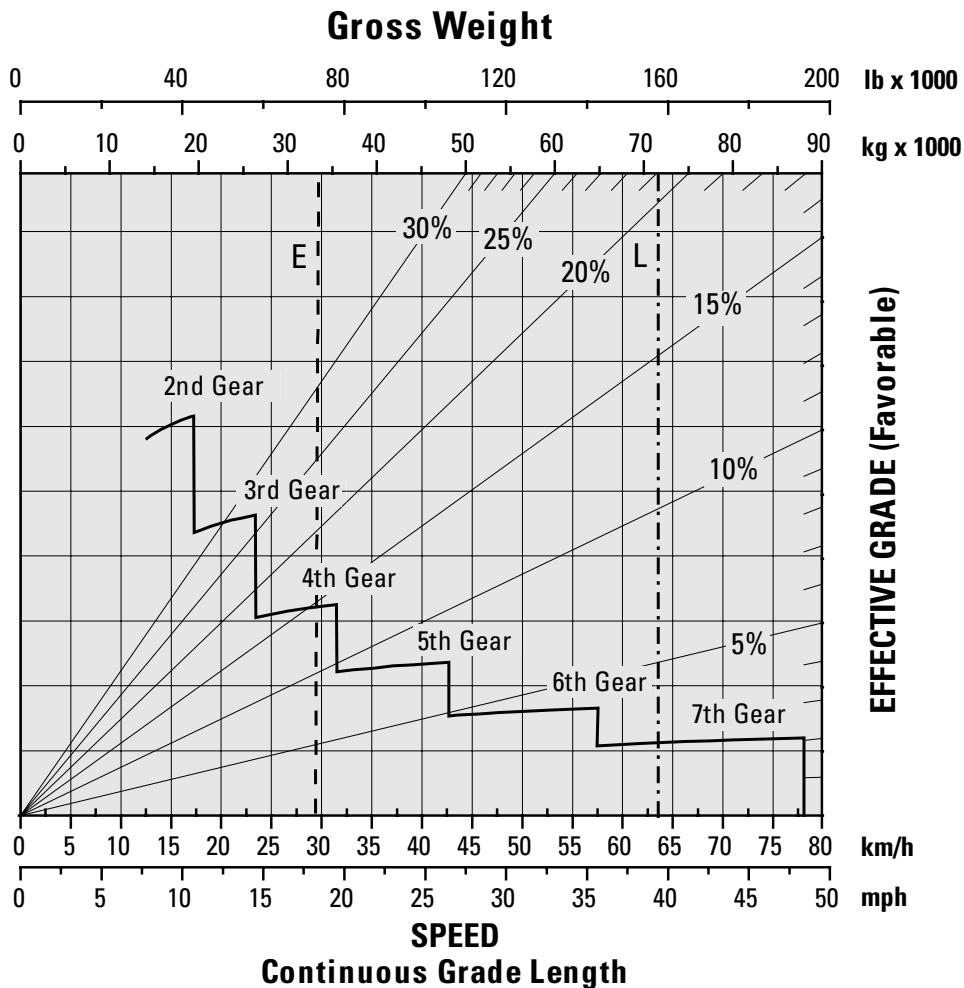

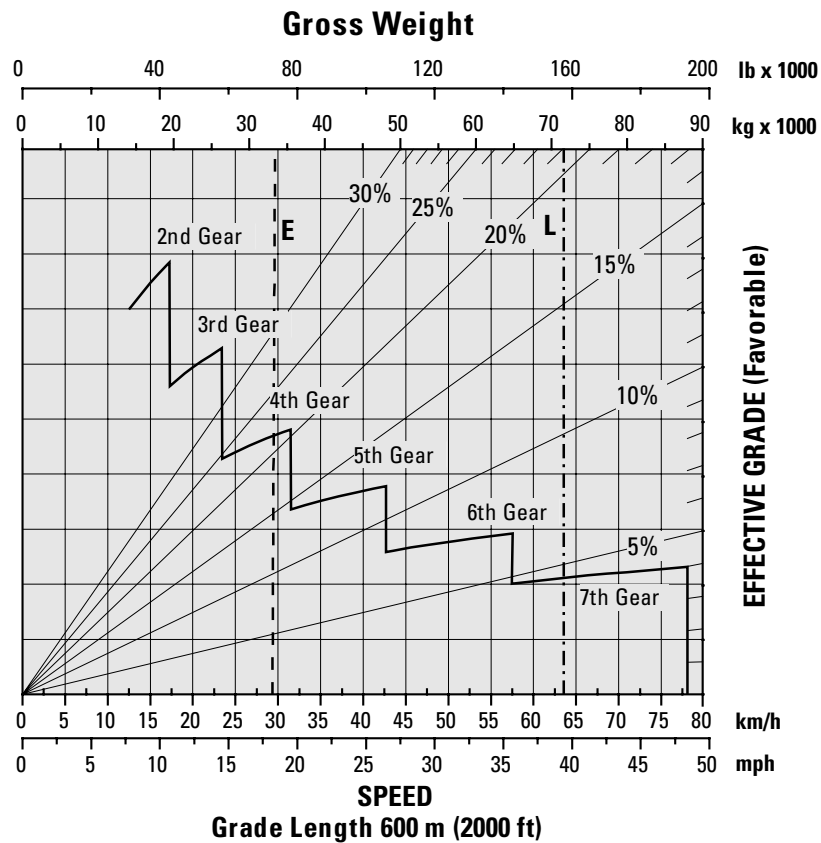
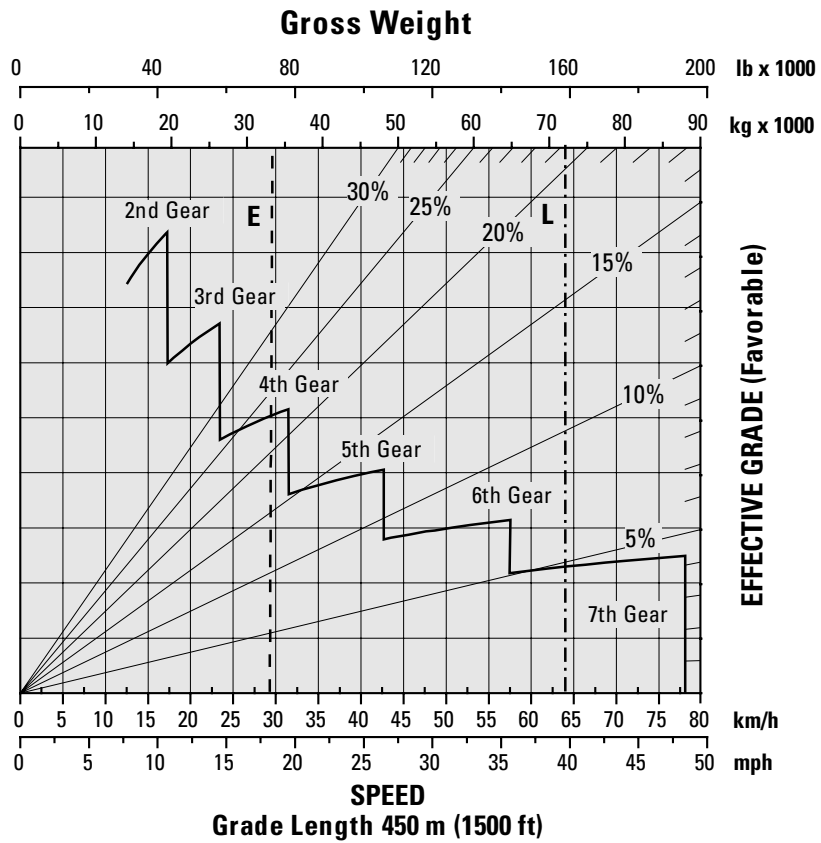



# Retarding Performance (continued)

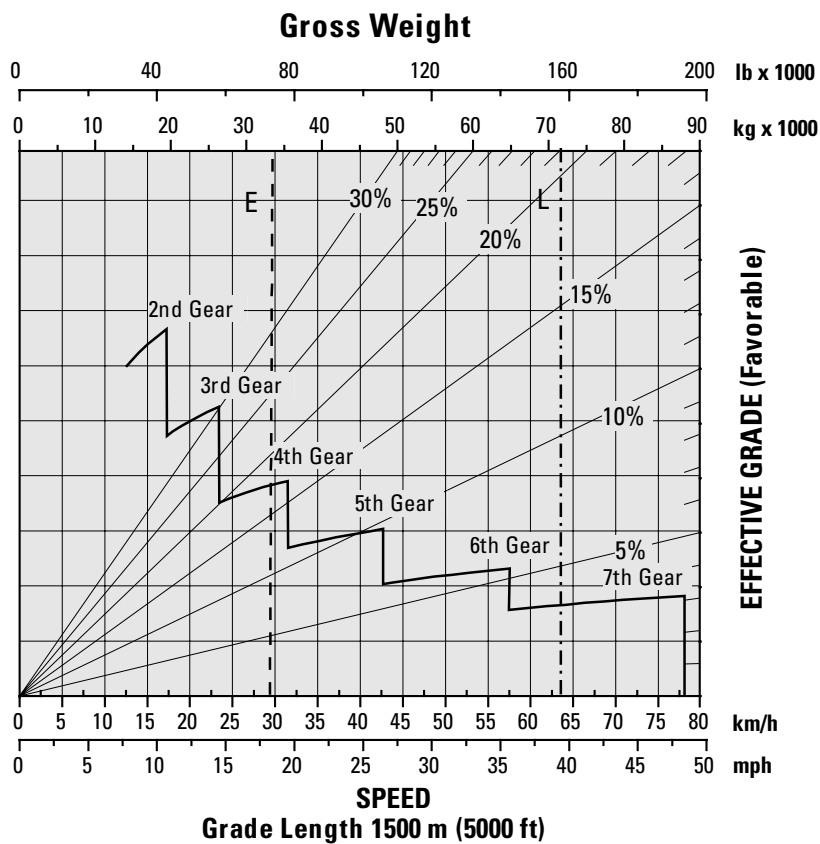
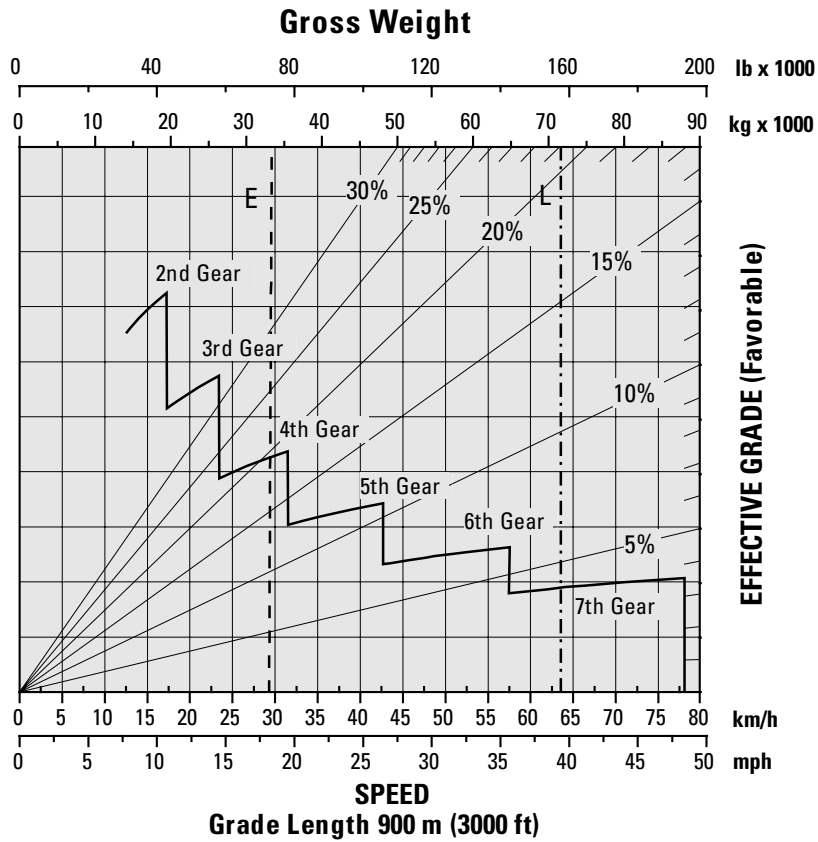

# Gradeability/Speed/Rimpull

To determine gradeability performance, read from gross weight down to the percent of total resistance. Total resistance equals actual percent grade plus one percent for each 10 kg/tonne (20 lb/ton) of rolling resistance. From this weight-resistance point, read horizontally to the curve with the highest obtainable gear, then down to maximum speed. Usable rimpull will depend upon traction available and weight on drive wheels.

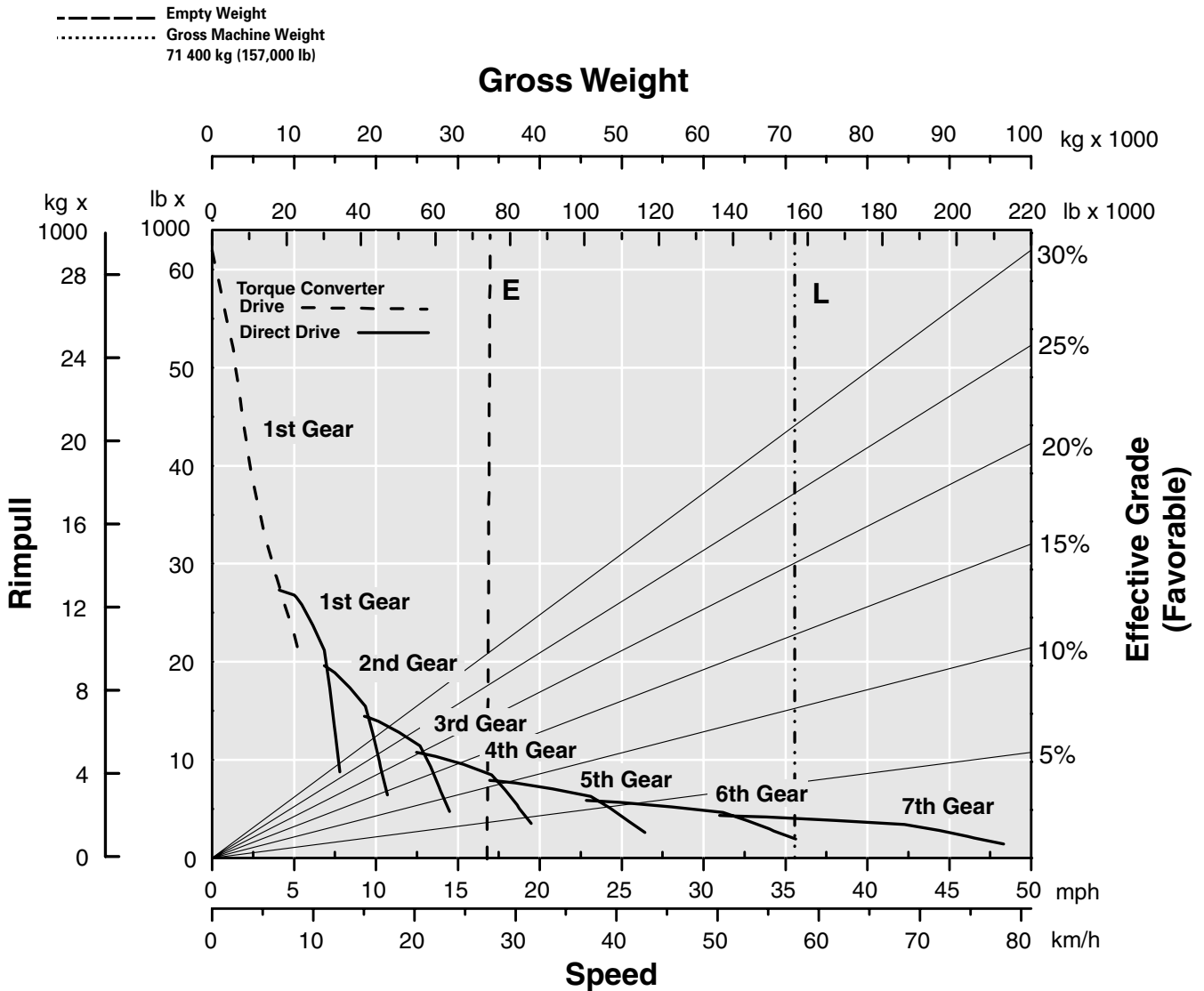

## Standard Equipment

*Standard equipment may vary. Consult a Caterpillar Dealer for specifics.*

Air horn, electric	Heater/defroster 11 070 kCal (43,930 Btu)
Air line dryer	Hoist lever, fingertip-actuated
Alternator, 50-amp	Lighting system
Auxiliary jump start receptacle	Backup light
Backup alarm	Dome/courtesy light
Battery disconnect switch, ground level	Hazard and directional signals, LED
Body mounting group	Headlights, halogen, with dimmer
Brakes	Stop/tail lights, LED
Caliper disc (front)	Mirrors, right and left
Oil disc (rear)	Power port, 24-volt
Parking	Precleaner
Secondary	QuickEvac™ System
Brake (front) disconnect switch	Reservoirs (separate)
Brake heat exchanger	Brake/hoist
Brake release motor for towing	Steering
Cab, ROPS	Transmission/torque converter
Caterpillar Contour Series air suspension seat	Retarder
Coat hook	Rock ejectors
Cup holder	Seat belts, retractable
Insulated and sound-suppressed	Seat, passenger
Radio-ready	Service platform, bolt-on
Storage compartment	Starting, electric
Sun visor	Steering, automatic supplemental, electric
Tinted glass	Steering wheel, padded, tilt, telescopic
Crankcase guard	Tires, 18.00-33, radial
Diagnostic connection port, 24-volt	Tow hooks, front
Driveline guard	Tow pin, rear
Electrical system, 24-volt	Transmission, electronically controlled automatic power shift
Electronic Monitoring System	with downshift/reverse shift inhibitor, neutralizer during
Filters, spin-on	dumping, neutral start switch, engine overspeed protection,
Gauges	directional shift management, programmable top gear,
Actual Gear Indicator	body-up shift limiter, economy shift mode and control
Air pressure	throttle shifting
Brake oil temperature	Vandalism protection locks
Coolant temperature	Window, electric power (operator)
Fuel	Windshield wipers and washer, electric intermittent
Hour meter, electric	
Odometer	
Speedometer	
Tachometer	



## Optional Equipment

With approximate changes in operating weights. Optional equipment may vary.  
Consult a Caterpillar Dealer for specifics.

	kg	lb		kg	lb
Air conditioning	90	200	Spare rim (330 mm) 13"	360	800
Automatic lube system	60	135	Traction Control System (TCS)	50	110
Automatic Retarder Control (ARC)	6	13	Truck Bodies:		
Clustered grease fittings	20	50	Dual slope body	7300	16,200
Engine coolant heater - 120-volt	3	7	Body liner for dual-slope body [Liner thickness - 16 mm (.063") floor, 8 mm (.031") front and side walls]	3200	7,000
Engine coolant heater - 240-volt	4	9	Flat floor body	7800	17,200
Engine ground level shut-off	80	180	Body liner for flat floor body [Liner thickness - 16 mm (.063") floor, 8 mm (.031") front and side walls]	3300	7,200
Ether starting aid	5	10	Truck Production Management System (TPMS)	45	100
Exhaust diverter/muffler	75	170	Wheel chocks	25	50
Fuel heater kit	5	12	Wiggins fast fuel change	2	5
Integrated brake control	56	123	Wiggins high speed oil change	1	2
Muffler	55	120			
Sound suppression package (2000/14/EC compliant)	136	300			

## Weight/Payload Calculation\*

(Example)

	Flat Floor		Dual-slope	
	kg	lb	kg	lb
Empty Chassis Weight	23 000	50,600	23 000	50,600
Fuel Correction (90% × 140 gal.)	400	882	400	882
Optional Attachments Weight				
Debris Allowance (4% of chassis)	+920	+2024	+920	+2024
Chassis Weight	24 320	53,506	24 320	53,506
Body Weight	7800	17,200	7300	16,200
Body Attachments Weight	+3300	+7200	+3200	+7000
Total Empty Operating Weight	35 420	77,906	34 820	76,706
<b>Target Payload</b>	<b>+35 980</b>	<b>+79,094</b>	<b>+36 580</b>	<b>+80 294</b>
Gross Machine Operating Weight	71 400	157,000	71 400	157,000

\*Note: Refer to Caterpillar's 10/10/20 Payload Policy for Quarry and Construction Trucks.

# 769D Off-Highway Truck

For more complete information on Cat products, dealer services, and industry solutions, visit us on the web at [www.CAT.com](http://www.CAT.com)

© 2001 Caterpillar  
Printed in U.S.A.

AEHQ5440-01 (12-01)

Replaces AEHQ5440

Materials and specifications are subject to change without notice.  
Featured machines in photos may include additional equipment.  
See your Caterpillar dealer for available options.

**CATERPILLAR**<sup>®</sup>