

773E

Off-Highway Trucks

CATERPILLAR[®]



Engine

Engine Model	Cat [®] 3412E	
Gross Power – SAE J1995	530 kW	710 hp
Flywheel Power	501 kW	672 hp

Operating Specifications

Nominal Payload Class	55.5 tonnes	61 tons
Body Capacity – SAE 2:1	35.2 m ³	46 yd ³

Approximate Weights – Dual Slope

Gross vehicle	99 300 kg	219,000 lb
---------------	-----------	------------

773E Features

Operator Station

Controls and gauges are positioned for productivity and comfort. Includes an air suspension seat and advanced electronic monitoring system.

Power Train – Engine

Features the 3412E diesel engine and HEUI™ for efficient operation.

Power Train – Transmission

The Cat seven-speed, power shift transmission gets the job done smoothly and quickly.

Engine/Power Train Integration

Cat Data Link System electronically combines engine, transmission, brake and operational information for optimum truck performance.

Oil-Cooled, Rear Disc Brakes

Designed and built for reliable, adjustment-free operation, superior performance and service life in comparison to shoe-type and dry-disc systems.

Integrated Braking Control (IBC)

Integrates optional Automatic Retarder Control and Traction Control System (TCS), with oil cooled rear disc brakes to enhance truck performance and improve operator confidence.

Structures

The Mild steel Cat truck frames provide flexibility, durability and resistance to impact loads. Castings and forgings in high stress areas increase structural strength.

Contents

Operator Station.....	3
Power Train – Engine	4
Power Train – Transmission	5
Engine/Power Train Integration.....	6
Oil-Cooled, Rear Disc Brakes.....	7
Automatic Retarder Control (ARC)	8
Integrated Braking Control (IBC).....	9
Truck Body	10
Structures.....	11
Serviceability/Customer Support	12
Systems/Applications.....	13
773E Off-Highway Truck Specifications	14
773E Standard Equipment.....	21
773E Optional Equipment	21
Notes.....	22



Time proven iron and modern technology combine to provide a highly productive, durable and reliable off-highway truck focused on our customers greatest need... lowest cost-per-ton.



Operator Station

Control ease and comfort maximize productivity

Ergonomic Controls at the Operator's Fingertips

The ROPS/FOPS cabin has electric power window, electro-hydraulic hoist lever, trainer's seat, front brake cut-off switch, backlit LED gear numbers, and optional heater and air conditioner. The hoist lever is electro-hydraulic and fingertip actuated, providing low impact body-down snubbing.

Electronic Monitoring System (EMS) – Critical Data in Three Separate Displays

- (1) Four-gauge cluster – coolant temperature, oil temperature, brake air pressure, fuel level
- (2) Tachometer, digital speedometer, actual gear indicator
- (3) Message center module

Contour Series Air Suspension Seat and Tilt-Telescoping Steering Wheel

Standard and fully adjustable, including an adjustable right-hand armrest. Steering wheel's ergonomic grip improves comfort and control. Low effort steering system and foot-operated retarder reduce operator fatigue. Turn signal lever includes high beam actuator and electric windshield wiper controls.

Visibility in an Integral, Quiet ROPS/FOPS Cab

Exceptional all-around viewing area reduces fatigue and improves operator confidence and productivity. Cab is resiliently mounted and sound-suppressed for a quiet, protected work environment, and is radio-ready.

Truck Production Management System (TPMS) (Optional) Provides Payload and Cycle Time Data

- Cat technology uses strut pressure sensors and on-board processors to determine payload weight.
- Consistently accurate payloads improve efficiency by minimizing overloading and underloading.
- On-board computer stores 1,400 cycles of payload weight, cycle times, distances and more.

Power Train – Engine

Cat 3412E Turbocharged engine with a HEUI™ fuel system

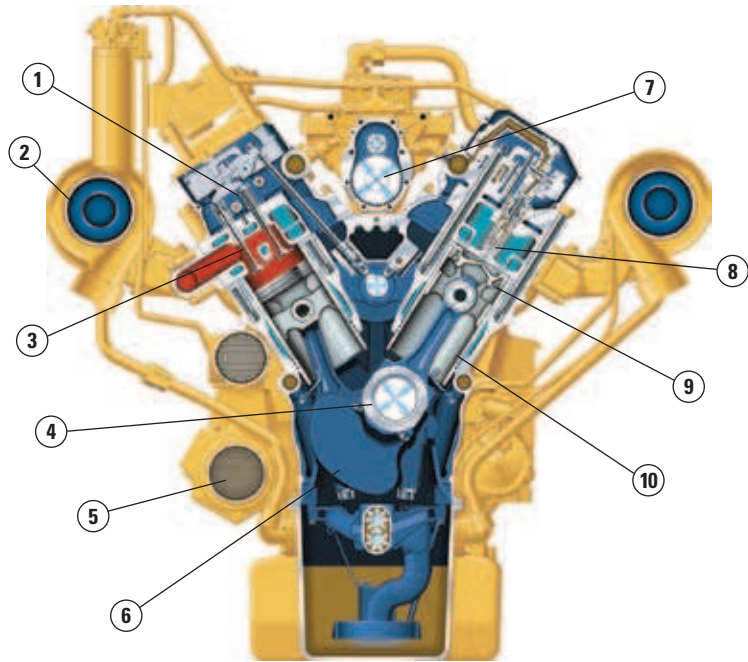

Cat 3412E Air to Air After Cooled Diesel Engine

The four stroke design uses long power strokes for complete fuel combustion and optimum efficiency. High displacement/low speed rating extends engine life and meets China Nonroad Stage II Emissions Standards.

Engine

- 1) Valve Rotators
- 2) Turbocharger
- 3) Stellite-Faced Valves
- 4) Steel-Backed, Copper-Bonded Bearings
- 5) Oil Cooler
- 6) Forged Crankshaft
- 7) Adjustment-Free, Fuel Injection Pumps
- 8) Hydraulic Injectors
- 9) Forged Steel Pistons
- 10) Full-length, Water-Cooled Cylinder Liners

40 Percent Torque Rise Means Faster Cycle Times

High lugging force during acceleration and less downshifting on grade or rough underfoot conditions. Also effectively matches gear shift points for maximum efficiency.

3412E Power and Reliability Features

- High pressure injection
- Full electronic control
- Copper-bonded crankshaft bearings
- Hardened crankshaft journals
- Dry-type, radial seal air cleaners (primary, secondary elements, precleaner)

HEUI™ Delivers Excellent Fuel Control

Electronically monitors operator and machine inputs to optimize engine performance. Independently controls injection pressure, timing and duration over the engine operating range. Rate shaping technology modifies the heat release characteristics of the combustion process for significant decreases in sound and exhaust emission levels.

Electronic Control Module (ECM)

The ECM monitors key functions and logs critical indicators. The Electronic Technician can access this diagnostic information for easier maintenance and repair.



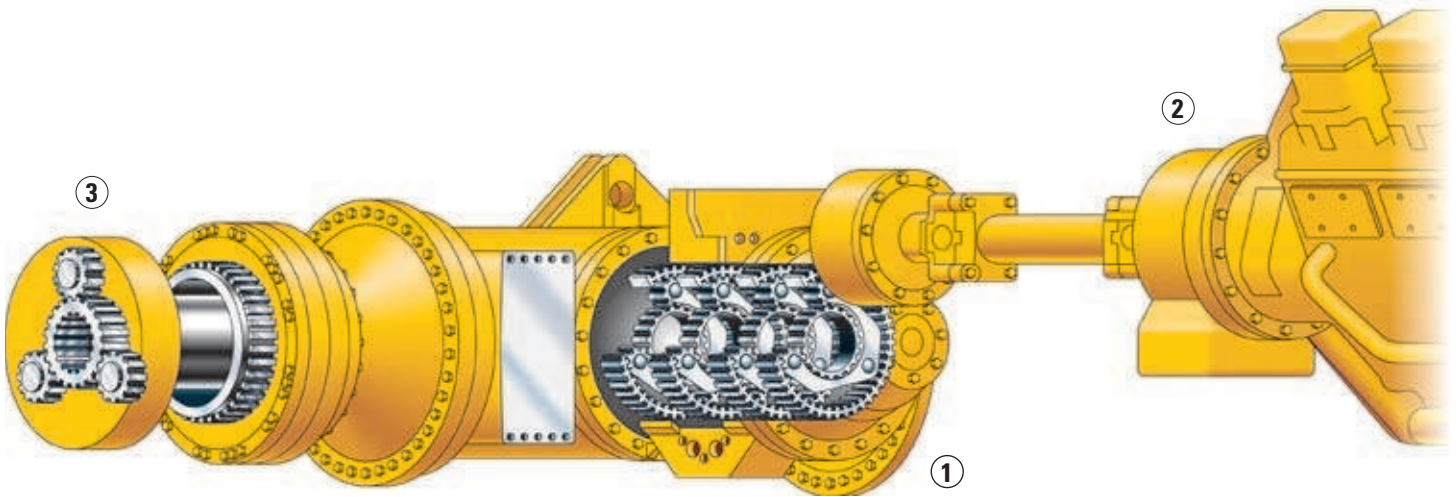

Power Train – Transmission

The Cat transmission gets the job done smoothly and quickly.

1) Lock-up Torque Converter Extends Transmission Life and Increases Operator Comfort

High rimpull and cushioned shifts with direct drive's efficiency and performance.

- Engages at approximately 6.9 km/h (4.3 mph), delivering more power to the wheels
- Quickly releases/re-engages during shifts, maintaining power wind-up

2) Cat Seven-Speed, Power Shift Transmission

A modulating pressure valve regulates clutch pressure to ease clutch engagement, reducing shock loads.

- Patented rotating clutch pressure seals minimize drag losses and improve reliability
- 35 percent gear splits between all gears match Cat engine design for optimum use of engine power with minimized shifting and torque converter use
- Matched with the 3412E engine for constant power over a wide range of operating speeds.
- Seven speeds forward, one reverse; second through seventh gears are direct drive
- First gear has both torque converter drive and direct drive

3) Final Drives

Final drive and differential torque multiplication of 17.48:1 further reduces stress on the drive train.

Axles, Wheel and Rims

Full floating axles are shot-peened to relieve internal stresses and increase durability. Rolled splines also provide increased service life. Cast rear wheels and center-mount rims are mounted using studs and nuts for maximum reliability.

Engine/Power Train Integration

Combining engine control module (ECM) with the transmission controller

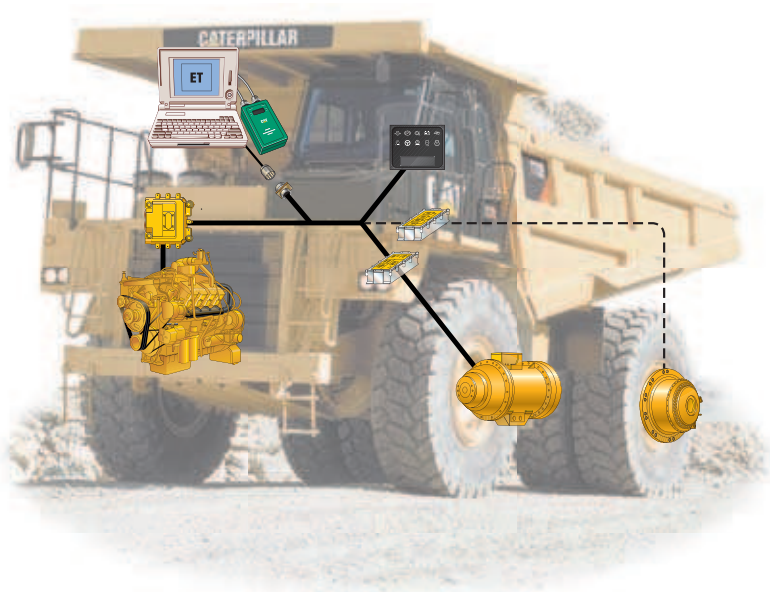

Integrating Systems Improves Performance

Electronic control of the engine and transmission improves efficiency, lowers operating costs and extends machine life.

Cat Data Link

Integrates machine computer systems:

- Controlled Throttle Shifting regulates engine speed during shifts to reduce driveline stress, and deliver smoother shifts and longer component life.
- Economy Shift Mode modifies engine maps for lower fuel consumption.
- Directional Shift Management regulates engine speed during directional shifts to prevent damage.
- Elevated Idle Neutral Coast Inhibitor helps prevent shifts to neutral at speeds above 6.5 km/h (4 mph).
- Body-up Shift Inhibitor helps prevent transmission shifts above a preprogrammed gear without the body fully lowered.
- Event Memory stores operational data for Electronic Technician access. Data includes:
 - Shift histograms
 - Operator-induced events
 - Lock-up clutch counter
 - Machine/Transmission overspeed

Electronic Technician (Cat ET)

Accesses engine and transmission data stored by the Cat Data Link System, and displays the status of all engine parameters.

Electronic Monitoring System (EMS)

Displays information on request, and alerts the operator to abnormal conditions with a three-category warning system.

Optional Attachments

- Automatic Retarder Control (ARC) automatically controls retarding on grade, maintaining $\pm 2,230$ rpm.
- Traction Control System (TCS) improves performance in poor underfoot conditions by electronically monitoring and controlling wheel slip.
- Integrated Brake Controller (IBC) combines ARC and TCS, reducing electronic components and electrical lines.

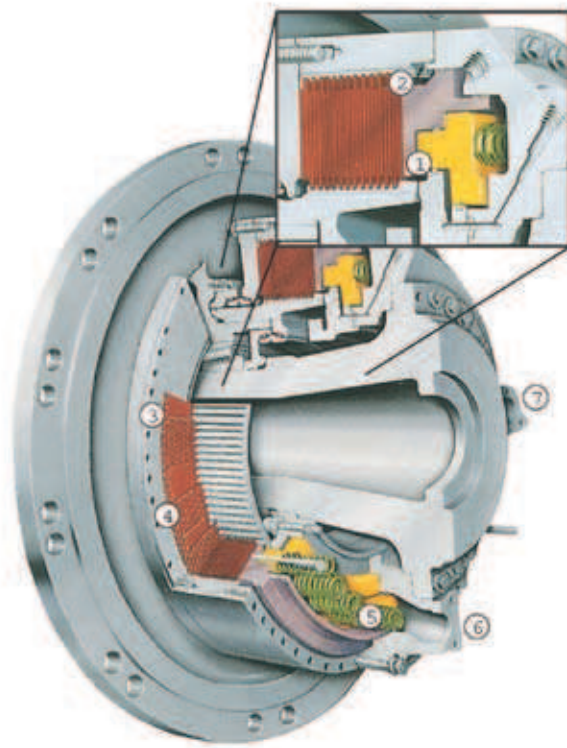

Oil-Cooled, Rear Disc Brakes

Rear braking lets the operator concentrate on the haul road.

Brakes

1) Parking/Secondary Piston, 2) Service/Retarding Piston, 3) Friction Discs, 4) Steel Plates, 5) Actuating Springs, 6) Cooling Oil In, 7) Cooling Oil Out

Multiple Disc Brakes – Exceptional, Fade-Resistant Braking and Retarding

Cat multiple disc brakes use continuous forced oil-cooling. The optional ARC and TCS utilize the oil-cooled rear brakes to enhance truck performance and increase productivity.

Oil-Cooled Rear Disc Brakes

Designed and built for reliable, adjustment-free operation providing superior performance and service life in comparison to shoe-type and dry-disc systems. The system combines service, retarding and parking brake functions in a single unit. If hydraulic system pressure drops below a certain level, the spring applied secondary piston automatically applies the brake.

Oil Film Prevents Direct Contact Between Discs

Absorbing the braking forces by shearing oil and carrying heat away, this design extends brake life.

Secondary Braking

Spring-applied, hydraulically released, oil-cooled disc brakes are located on the rear axle. The front brakes will activate as part of the secondary system, even if switched out of service.

Parking Brakes

Spring-applied, hydraulically released parking brakes use wet disc brakes in the service system. A toggle switch activates the parking brake.

Pistons

A Caterpillar patented, two-piston design combines the service, secondary and parking brakes, along with retarding functions.

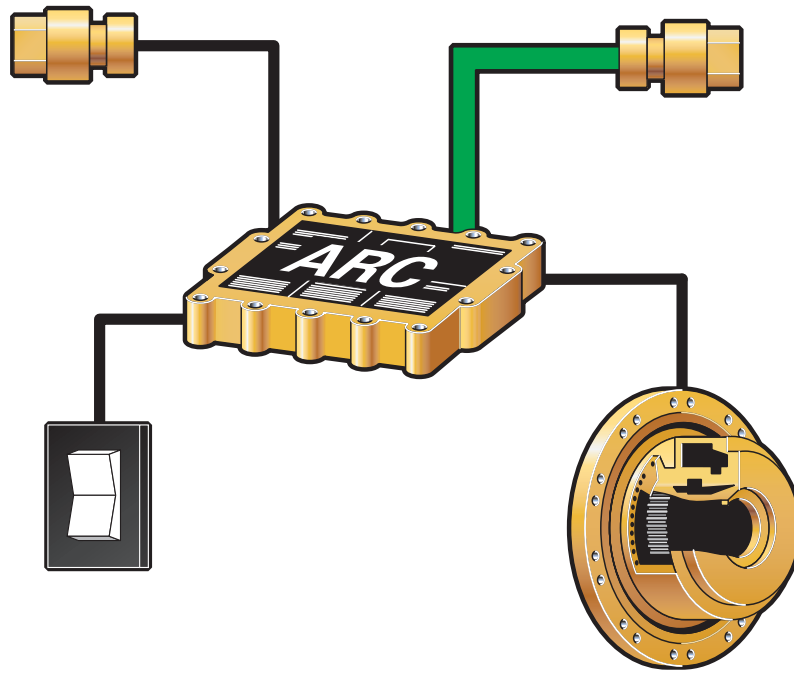

Automatic Retarder Control (ARC)

Better machine control, greater production

ARC Benefits include:

- Increased operating efficiency with faster downhill speeds. By maintaining consistently higher engine speeds, average truck speed will be higher than a manually controlled truck.
- Excellent controllability and reduced operator effort. Automatic brake modulation provides a smoother ride over manual modulation, allowing the operator to focus more on truck operation down the haul road.
- Improved component life, optimized system cooling capability and reduced torque fluctuations result from ARC's precision.
- Faster troubleshooting and diagnosis with self-diagnostic capability and the ability to communicate with ET through the Cat Data Link System.
- Operator awareness through electronic integration and EMS, alerting the operator to overspeed conditions and critical machine functions.

Traction Control System (TCS) (Optional)

- Senses rear wheel slip and automatically applies rear brakes to slow the spinning wheel.
- On-dash indicator shows the operator that TCS is engaged.
- Utilizes normal differential action for superior maneuvering in poor underfoot conditions and to reduce tire scuffing.
- TCS divides torque equally to reduce stress created on final drives and axles when torque is transferred to one side.
- Should sensors fail, the normal differential action is still available to maintain control and steering.

Integrated Braking Control (IBC)

Combines benefits of Automatic Retarding and Traction Control System

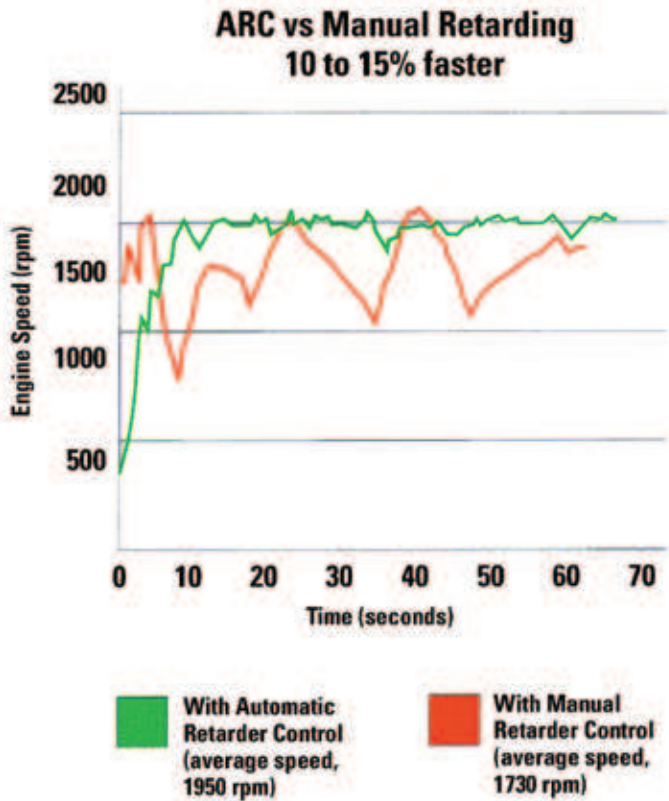

Automatic Retarder Control (Optional)

The ARC electronically controls braking on grade to maintain approximately 2,230 rpm (engine rpm is adjustable from 2,150-2,300 rpm in increments of 10 rpm). ARC is deactivated when the operator applies the brakes or throttle.

Engine Overspeed Protection

With the accelerator depressed and/or ARC turned off, ARC will automatically activate at 2,475 rpm to help avoid potentially destructive and often costly engine overspeeds.

Traction Control System (Optional)

Senses if rear wheel slip exceeds the set limit, and automatically applies rear brakes to slow the spinning wheel.

Operator Awareness

An on-dash indicator shows the operator that TCS is engaged.

Differential Action

Utilizes normal differential action to provide superior maneuvering in poor underfoot conditions. Also reduces tire scuffing as compared to positive lock differentials used on other systems.

Torque

TCS divides torque equally to reduce stress created on final drives and axles when torque is transferred to one side.

System Back-up

Should sensors fail, the normal differential action is still available to maintain control and steering.



Truck Body

Rugged body for varying applications

Designed To Handle a Variety of Material Densities.

Maximum payload in 3-5 passes with matched Cat loader in material over 1700 kg/m³ (2,900 lb/yd³).

Truck Body Features

- Sidewall and floor junctions use five-sided beams to resist impact loads and hauling stresses.
- Box-section beams increase durability in the floor, sidewalls, top rail, corner and cab canopy areas.
- 400 Brinell Steel wear surfaces provide excellent wear resistance and are easily cold welded.
- Two-stage hoist cylinders raise in 9.5 seconds, lower in 12.5 seconds.
- Standard Body comes exhaust heated with options including a full-time muffler or exhaust diverter.
- Custom attachments include tail end liner, sideboards and more, to help ensure rated payload.

Dual-Slope Body Delivers Lowest Cost-Per-Ton

Efficient in most construction and mining applications, but excels on rough haul roads and steeper grades.

Body Floor Construction

- 8° “V” Bottom – Centers loads, lowers the center of gravity, increases retention, reduces shock loads.
- 18° Ducktail and 9° Forward Body Slope – retains loads on 15% grades
- 12° Single Slope – Excellent wear characteristics and uniform dumping into hoppers, crushers and feeders.

Structures

The backbone of the Cat off-highway truck

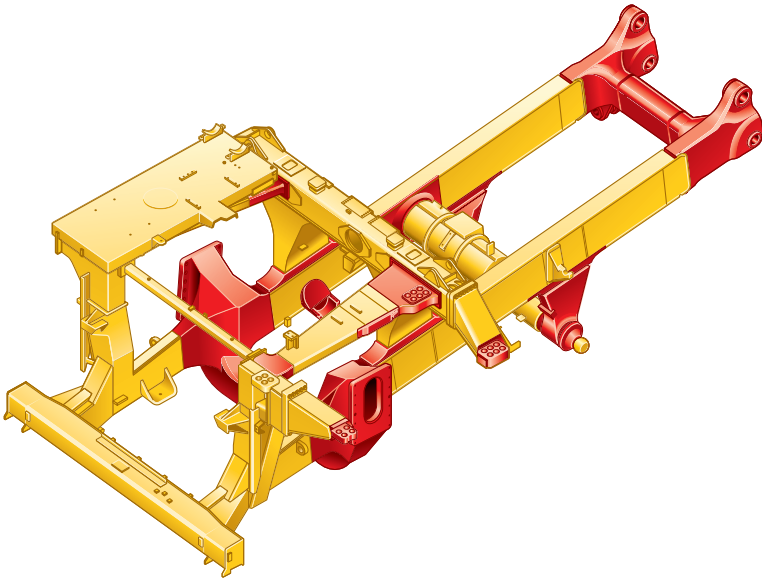

Box-Section Design

The 773E frame uses 20 castings in high stress areas with deep penetrating and continuous wrap-around welding. Mild steel provides flexibility, durability and resistance to impact loads even in cold climates.

Rollover Protection Structure (ROPS)

The ROPS attaches securely to four castings welded into the frame.

Frame Features Include:

- Integral front bumper and front box beams for suspension cylinder and ROPS support
- Box-section rear crossmember for body and ROPS support with attachment points for maintenance platform and rear engine hood hinge support
- Castings provide additional strength in critical stress areas
- Mild steel plates (290 MPa [42,000 psi] minimum yield strength) and castings (241 MPa [35,000 psi] minimum yield strength) provide flexibility, durability and easy field maintenance.
- Castings provide additional strength in critical stress areas

Box-Section Frame Simplifies Access to Power Train Components

Open design reduces overall removal and installation time, lowering repair costs. Repairs can be made without preheating in ambient temperatures above 16° C (60° F) using readily available welding supplies.

Suspension System Dissipates Haul Road and Loading Impacts

Four independent suspension cylinders absorb shocks. Rear cylinders allow axle oscillation and absorb bending and twisting stresses. Front cylinders act as steering kingpins, for maneuverability and reduced maintenance.

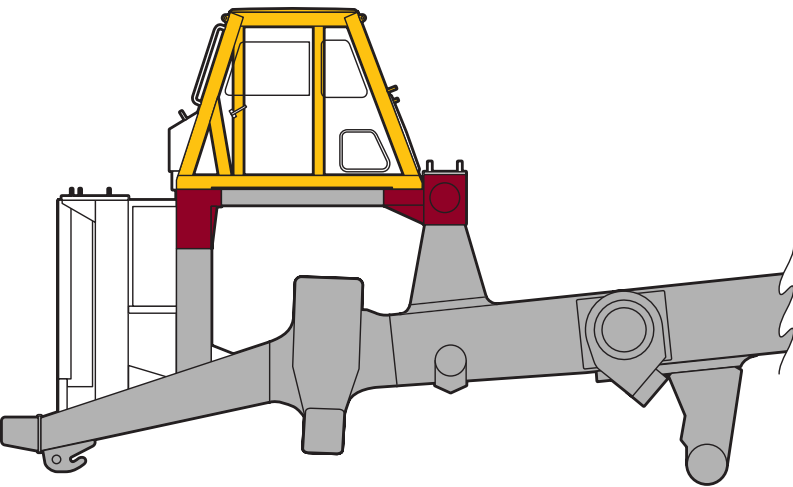



Serviceability/Customer Support

Cat Dealers offer their total commitment to customer support.

Improved Serviceability and Machine Availability

Allows 30-50% faster engine service (changing most oil and filters). Improves service scheduling, allows servicing during normal work hours and reduces total engine service time.

Other Serviceability Features:

- Safe, convenient maintenance with a machine platform and ground level battery disconnect.
- On-Board EMS provides a 3-category warning system and quick access to stored diagnostic data.
- Off-Board Diagnostics with Cat ET reduces downtime and lowers operating costs.
- Radial Seal Filters are easy to change, and vertical, spin-on filters simplify servicing.
- Quick Coupler Taps and S·O·SSM analysis points make oil sampling quick, clean.
- Sealed Electrical Connectors lock out dust and moisture. Color-coded wiring is standard.

Machine Management Service

Cat Dealers help you match the right machine to the job. Preventative maintenance programs, S·O·S oil analysis and technical analysis programs, plus repair option analysis, keep machines up and running. Training for operators and mechanics, and TPMS data analysis maximize your machine investment.

Parts Availability

The Caterpillar worldwide computer network locates parts instantly to minimize machine downtime.

Literature Support

Caterpillar manuals are easy to use and help provide the full value of any equipment investment.

Systems/Applications

The 773E is designed for versatility.

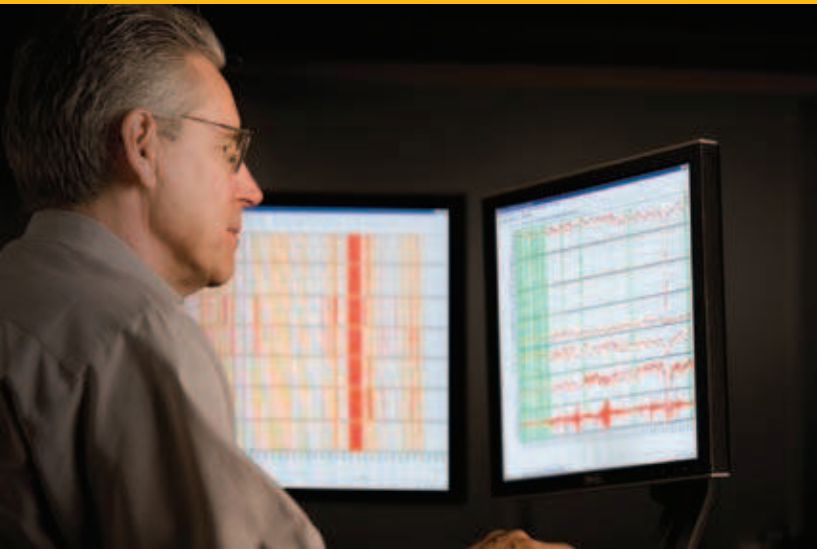

Machine Configuration Options

Caterpillar offers a variety of machine configuration options to help meet customer needs.

Body Options

Include a full line of standard and custom designs based on specific customer preference, material density, loading tool and site conditions.

Tire Options

A full line of tire options, representing various manufacturers, is offered by Caterpillar to maximize performance and life for specific applications.

Attachments

Give the customer options to tailor trucks for specific application requirements, including:

- Truck Production Management System
- Automatic Retarder Control
- Traction Control System
- Extended life brakes
- Muffler/exhaust diverter

System Approach

The Caterpillar system approach increases efficiencies through common design. Haul trucks, loaders, excavators, tractors, engines for generator sets and pumps, all designed by Caterpillar, use common components, parts and design. Commonality reduces customer parts stock, improves parts availability.

Cat Product Analysis Team (PAT)

Combined with Cat software programs, can assist customers with detailed, application evaluation.

Loader Match

Designed to work as part of a system, the 773E is best matched to the following Cat loaders:

- 988G – five pass/match
- 990H – three pass/match

773E Off-Highway Truck Specifications

Engine		
Engine Model	Cat® 3412E	
Rated Engine Speed	2,000 rpm	
Gross Power	530 kW	710 hp
– SAE J1995		
Net Power	501 kW	672 hp
– SAE J1349		
Net Power – Cat	501 kW	672 hp
Flywheel Power	501 kW	672 hp
Net Power	501 kW	672 hp
– ISO 9249		
Net Power	501 kW	672 hp
– 80/1269/EEC		
Net Power	681 PS	
– DIN 70020		
Number of Cylinders	12	
Peak Torque	3434 N·m	2,533 lb ft
Torque Rise	40%	
Bore	137 mm	5.4 in
Stroke	152 mm	6 in
Displacement	27 L	1,649 in ³

- Gross power meets ISO 3046-02 standards.
- Flywheel power meets ISO 9249, SAE J1349 JUN95 and EEC 80/1269 standards.
- These engine ratings apply at 2,000 rpm when tested under the specified condition for the specified standard.
- Power rating conditions based on standard conditions of 25° C (77° F) and 99 kPa (29.32 in Hg) dry barometer, using 35° C (95° F) API gravity fuel having an LHV of 42 780 kJ/kg (18,390 Btu/lb) when used at 30° C (86° F) (reference a fuel density of 838.9 g/L [7.001 lb/gal]).
- Net power advertised is the power available at the flywheel when the engine is equipped with fan, air cleaner, muffler and alternator.
- No derating required up to 2300 m (7,500 ft) altitude.
- Meets China Nonroad Stage II Emissions Standards.

Weights – Approximate		
Target Gross	99 300 kg	219,000 lb
Machine Operating		
Weight		
Chassis Weight	30 200 kg	66,579 lb
Body Weight	9210 kg	20,304 lb

- Tail end Liner (Price List)

Operating Specifications		
Nominal Payload	55.5 tonnes	61 tons
Class		
Top Speed – Loaded	62.2 km/h	38.6 mph
Body Capacity	26.6 m ³	34.8 yd ³
– Struck		
Body Capacity	35.2 m ³	46 yd ³
– SAE 2:1		
Steer Angle	31 Degrees	
Turning Diameter	22 m	72 ft 2 in
– Front		
Turning Circle	25 m	82 ft
Clearance Diameter		
Raise Time	9.5 Seconds	
Lower Time	12.5 Seconds	

- Refer to the Caterpillar Mining Truck 10/10/20 Payload Guideline, TEKQ0616.

Transmission		
Forward 1	9.9 km/h	6.2 mph
Forward 2	13.9 km/h	8.6 mph
Forward 3	18.8 km/h	11.7 mph
Forward 4	25.2 km/h	15.7 mph
Forward 5	34.1 km/h	21.2 mph
Forward 6	45.9 km/h	28.5 mph
Forward 7	62.2 km/h	38.6 mph
Reverse	13.1 km/h	8.1 mph

Final Drives	
Differential Ratio	3.64:1
Planetary Ratio	4.8:1
Total Reduction Ratio	17.48:1

- Planetary, full floating

Brakes		
Brake Surface	1395 cm ²	216 in ²
– Front		
Brake Surface – Rear	61 269 cm ²	9,496 in ²
Brake Standards	ISO 3450: 1996	

- Meets ISO 3450: 1996 standards up to 99 300 kg (219,000 lb) gross operating weight.

Body Hoists		
Pump Flow	491 L/min	130 gal/min
– High Idle		
Relief Valve Setting	17 225 kPa	2,500 psi
– Raise		
Relief Valve Setting	3445 kPa	500 psi
– Lower		
Body Raise Time	9.5 Seconds	
– High Idle		
Body Lower Time	12.5 Seconds	
– Float		
Body Power Down	17.51 Seconds	
– High Idle		

- Twin, two-stage hydraulic cylinders mounted inside the main frame; double-acting cylinders in second stage.
- Power raise in both stages and power down in second stage.

Capacity – Dual Slope – 100% fill factor		
Heaped 2:1 (SAE)	35.2 m ³	46 yd ³
Struck	26.6 m ³	34.8 yd ³
Heaped 3:1	32.4 m ³	42.4 yd ³
Heaped 1:1	43.3 m ³	56.6 yd ³

Weight Distributions – Approximate

Front Axle – Empty	47.3%
Front Axle – Loaded	33.3%
Rear Axle – Empty	52.7%
Rear Axle – Loaded	66.7%

Suspension

Effective Cylinder Stroke – Front	234 mm	5.2 in
Effective Cylinder Stroke – Rear	149 mm	5.9 in
Rear Axle Oscillation	8.1 Degrees	

Approximate Weights – Dual Slope

Gross vehicle	99 300 kg	219,000 lb
Chassis	30 200 kg	66,579 lb
Body	9210 kg	20,304 lb
Standard liner	3900 kg	8,600 lb
Front axle – empty	47.3%	
Front axle – loaded	33.3%	
Rear axle – empty	52.7%	
Rear axle – loaded	66.7%	

Service Refill Capacities

Fuel Tank	700 L	185 gal
Cooling System	122 L	32 gal
Crankcase	68 L	18 gal
Differentials and Final Drives	155 L	41 gal
Steering Tank	34 L	9 gal
Steering System (Includes Tank)	60 L	16 gal
Torque Converter/ Brake/Hoist Hydraulic Tank	133 L	35 gal
Brake/Hoist System (Includes Tank)	307 L	81 gal
Torque Converter/ Transmission System	53 L	14 gal
Torque Converter/ Transmission System (Includes Sump)	72 L	19 gal

Tires

Standard Tire	24.00-R35 (E4)
---------------	----------------

- Productive capabilities of the 773E truck are such that, under certain job conditions, TKPH (TMPH) capabilities of standard or optional ties could be exceeded and, therefore, limit production.
- Caterpillar recommends the user evaluate all job conditions and consult the tire manufacturer to make proper tire selection.

ROPS

ROPS/FOPS Standards	Standards Meets SAE J1040 May94 and ISO 3471: 1997
---------------------	--

- Integral Rollover Protective Structure (ROPS) is offered by Caterpillar as standard equipment.
- When properly installed and maintained, the cab offered by Caterpillar when tested with doors and windows closed as per work cycle procedures specified in ANSI/SAE J1166 May 90, results in an operator sound exposure Leg (equivalent sound level) of 79 dB (A).
- The operator A-weighted sound exposure level can be used in conjunction with OSHA, MSHA and EEC Occupational Noise Exposure Criteria.

Sound

Sound Standards	Meets SAE J88 APR95
-----------------	---------------------

- This machine, in standard configuration, when measured and operated per the prescribed modes has a 15 m sound pressure level of 84 dB (A) for the mode that gives the highest level.

Steering

Steering Standards	Steering Standards Meets SAE J1511 FEB94 and ISO 5010: 1992	
Steer Angle	31 Degrees	
Turning Diameter	22 m	72 ft 2 in
Front Wheel Track		
Turning Circle	25 m	82 ft 0 in
Clearance Diameter		

- Separate hydraulic system prevents cross contamination. Steering wheel effort is low and steering wheel cycle times are reduced with a new variable-displacement, piston type steering pump.

773E Off-Highway Truck Specifications

Dimensions

All dimensions are approximate

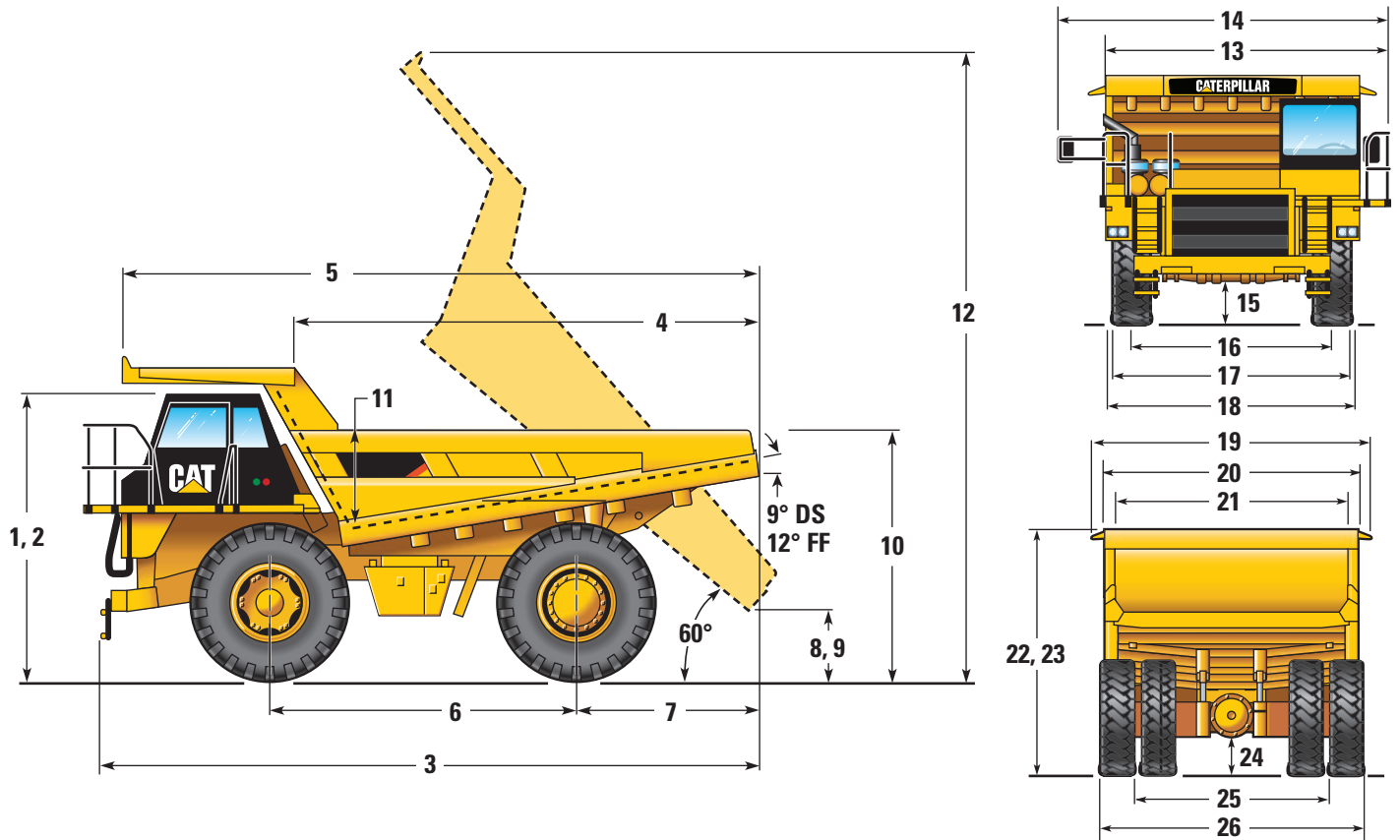

1	Height, top of ROPS, empty	4000 mm	13 ft 2 in
2	Height, top of ROPS, loaded	3900 mm	12 ft 10 in
3	Length, overall	9120 mm	29 ft 11 in
4	Length, inside body	6400 mm	21 ft
5	Length, overall body	8535 mm	28 ft
6	Wheelbase	4191 mm	13 ft 9 in
7	Rear axle to tail	2782 mm	9 ft 2 in
8	Dump clearance, empty	676 mm	2 ft 3 in
9	Dump clearance, loaded	566 mm	1 ft 11 in
10	Height, loading - empty	3773 mm	12 ft 5 in
11	Depth, inside body - maximum	1805 mm	5 ft 11 in
12	Height overall, body raised	8787 mm	28 ft 10 in
13	Width, left railing to right side body	4316 mm	14 ft 2 in
14	Width, operating	5076 mm	16 ft 10 in
15	Engine guard clearance	667 mm	2 ft 2 in
16	Width, front tire centerline	3275 mm	10 ft 9 in
17	Width, outside front tires	3966 mm	13 ft 0 in
18	Width, cab	4040 mm	13 ft 5 in
19	Width, overall canopy	4398 mm	14 ft 5 in
20	Width, outside body	3910 mm	12 ft 10 in
21	Width, inside body	3658 mm	12 ft
22	Height, front canopy, empty	4393 mm	14 ft 5 in
23	Height, front canopy, loaded	4350 mm	14 ft 4 in
24	Rear axle clearance	591 mm	1 ft 11 in
25	Width, rear dual tire centerline	2927 mm	9 ft 7 in
26	Width, overall tire	4457 mm	14 ft 8 in

Continuous Grade Length

- - - - - Empty Weight
 Target Gross Machine Weight – 99 300 kg (219,000 lb)

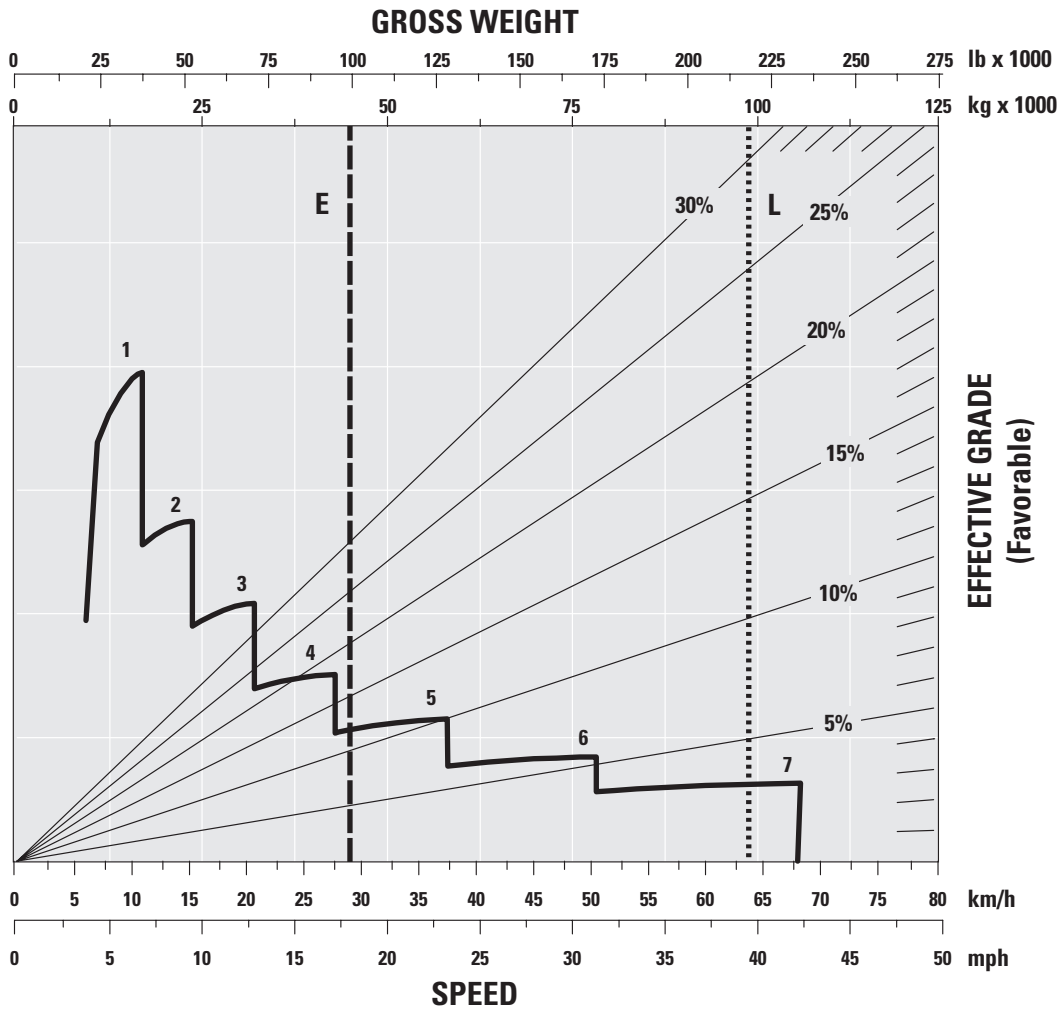

- 1 – 1st Gear
- 2 – 2nd Gear
- 3 – 3rd Gear
- 4 – 4th Gear
- 5 – 5th Gear
- 6 – 6th Gear
- 7 – 7th Gear

- E – Empty
- L – Loaded

773E Off-Highway Truck Specifications

Grade Length – 450 m (1,500 ft)

- — — — — Empty Weight
- Target Gross Machine Weight – 99 300 kg (219,000 lb)

- 1 – 1st Gear
- 2 – 2nd Gear
- 3 – 3rd Gear
- 4 – 4th Gear
- 5 – 5th Gear
- 6 – 6th Gear
- 7 – 7th Gear

- E – Empty
- L – Loaded

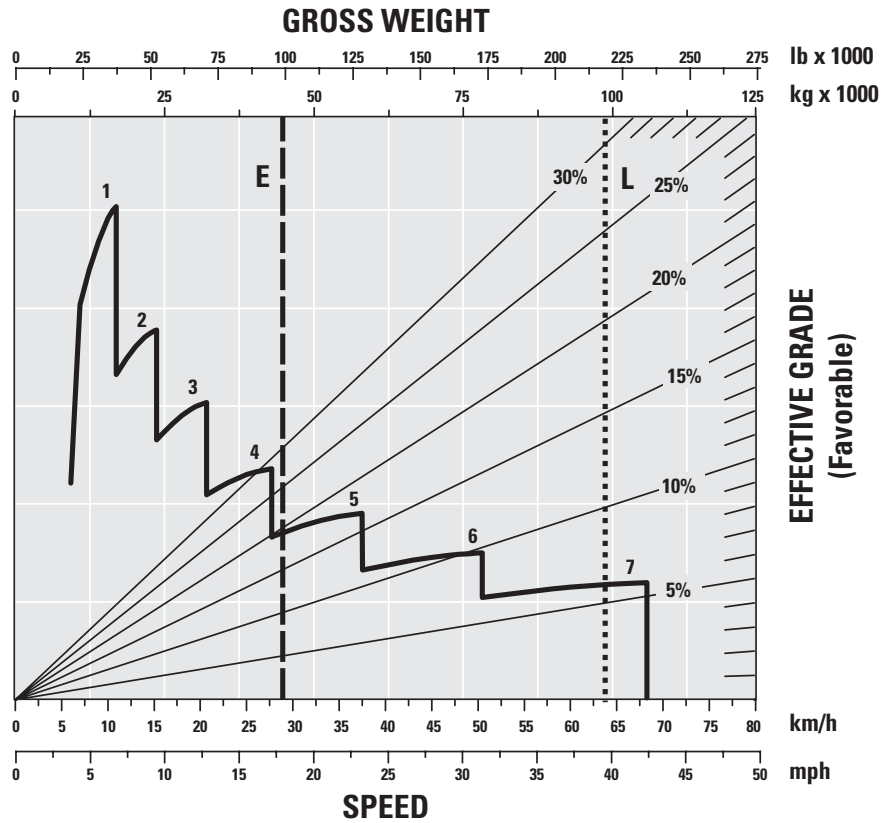

Grade Length – 600 m (2,000 ft)

- 1 – 1st Gear
- 2 – 2nd Gear
- 3 – 3rd Gear
- 4 – 4th Gear
- 5 – 5th Gear
- 6 – 6th Gear
- 7 – 7th Gear

- E – Empty
- L – Loaded

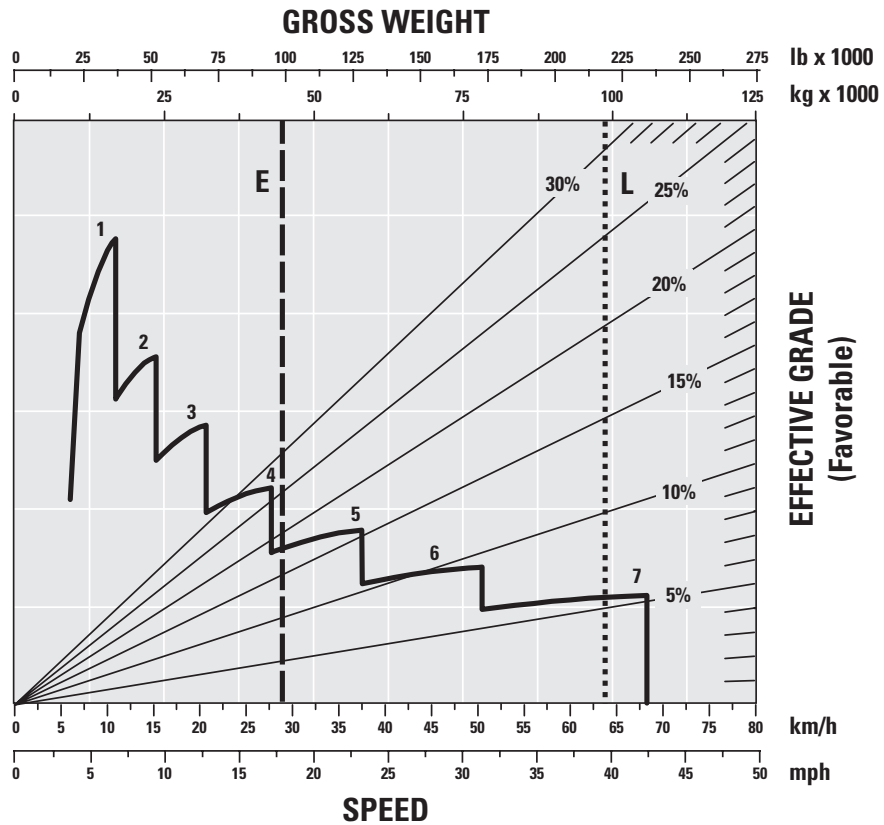

Grade Length – 900 m (3,000 ft)

- — — — — Empty Weight
- Target Gross Machine Weight – 99 300 kg (219,000 lb)

- 1 – 1st Gear
- 2 – 2nd Gear
- 3 – 3rd Gear
- 4 – 4th Gear
- 5 – 5th Gear
- 6 – 6th Gear
- 7 – 7th Gear

- E – Empty
- L – Loaded

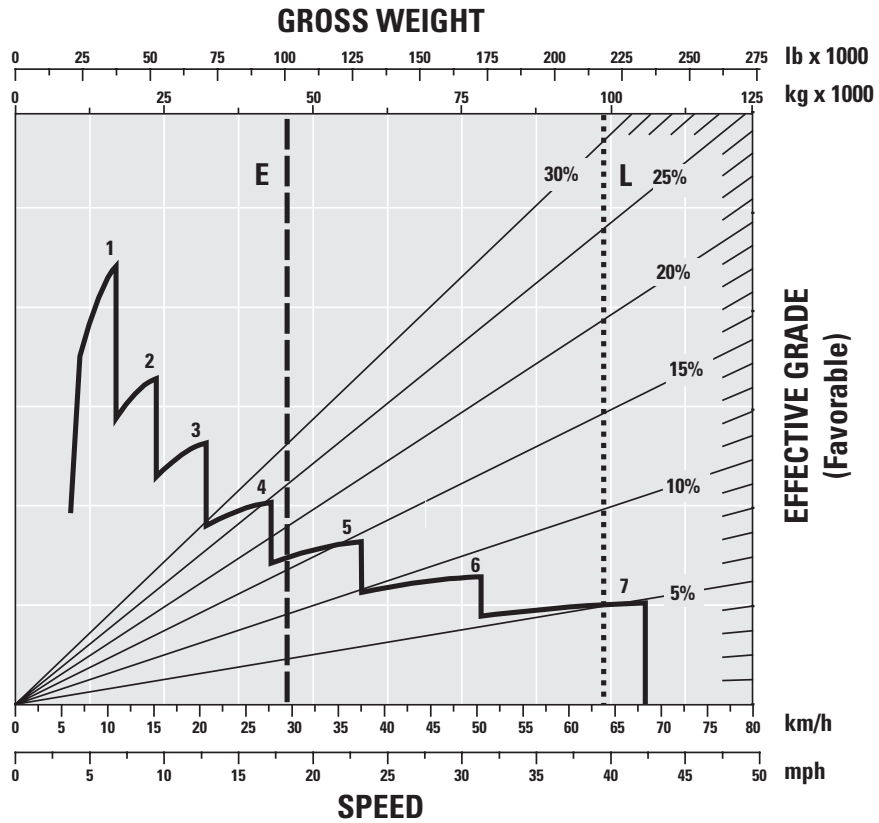

Grade Length – 1500 m (5,000 ft)

- 1 – 1st Gear
- 2 – 2nd Gear
- 3 – 3rd Gear
- 4 – 4th Gear
- 5 – 5th Gear
- 6 – 6th Gear
- 7 – 7th Gear

- E – Empty
- L – Loaded

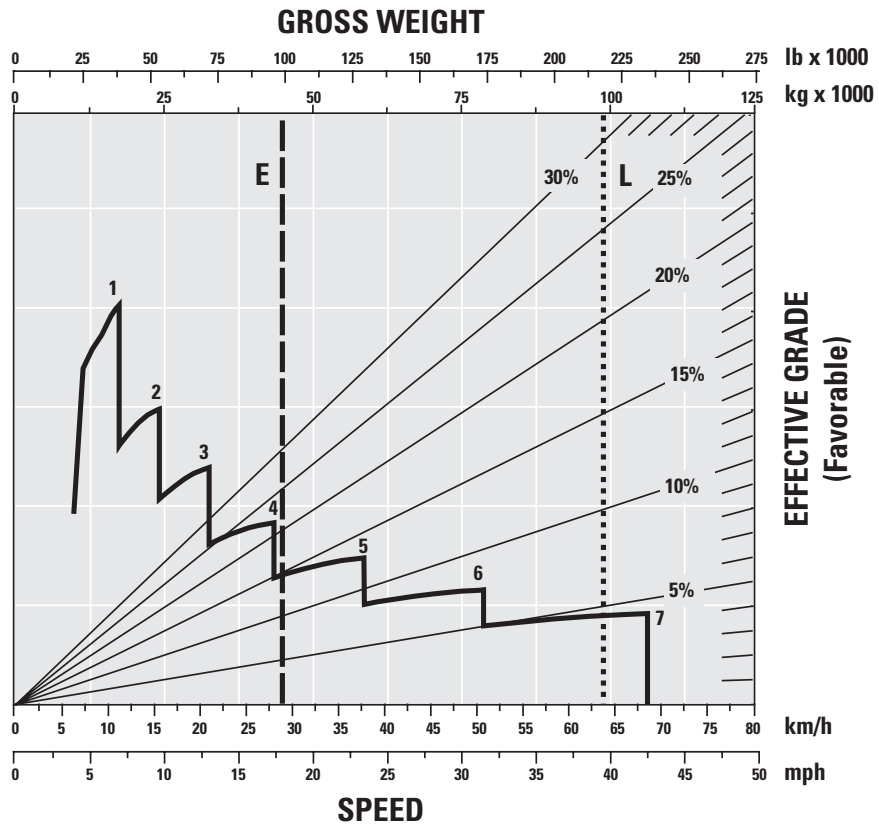

773E Off-Highway Truck Specifications

Weight/Payload Calculation

(Example)

CHASSIS	Dual Slope		Dual Slope with Liner	
	kg	lb	kg	lb
Empty Chassis Weight +10% fuel	30 200	66,579	30 200	66,579
Fuel Correction (90% – 185 gal – 7 lb/gal)	530	1,168	530	1,168
Debris Allowance (4% of empty chassis weight)				
Total Chassis Weight	30 730	67,748	30 730	67,748
BODY				
Body Weight	9210	20,305	9210	20,305
Body Attachment Weights			3900	8,598
Total Body Weight	+9210	+20,305	+13 110	+28,903
Total Empty Operating Weight	39 940	88,053	43 840	96,651
Target Payload	59 360	130,866	55 460	122,268
Gross Machine Operating Weights	99 300	219,000	99 300	219,000

* Refer to the Caterpillar 10/10/20 Payload Policy for Quarry and Construction.

773E Standard Equipment

Standard equipment may vary. Consult your Cat dealer for details.

Air cleaners, dry-type, radial seal, primary and secondary elements	Crankcase guard	Reservoirs (separate) –
Air horn, electric	Diagnostic connection port, 24-volt	Brake/hoist
Air line dryer	Drive line guard	Steering
Alternator, 50-amp	Electrical system, 24-volt	Transmission/torque converter
Auxiliary jump start receptacle	Electronic Monitoring System	Retarder
Backup alarm	Filters, spin-on	Rock ejectors
Batteries, 12V (2), low maintenance	Gauges –	Seatbelts, retractable
Battery disconnect switch, ground level	Actual Gear Indicator	Seat, passenger
Body mounting group	Air pressure	Service platform, bolt-on
Brakes –	Brake oil temperature	Starting, electric
Caliper disc (front)	Coolant temperature	Steering, automatic supplemental, electric
Oil disc (rear)	Fuel	Steering wheel, padded, tilt, telescopic
Parking	Hour meter, electric	Tires, 24.00-35, radial
Secondary	Odometer	Tow hooks, front
Brake (front) disconnect switch	Speedometer	Tow pin, rear
Brake heat exchanger	Tachometer	Transmission –
Brake release motor, for towing	Hoist lever, fingertip-actuated	electronically controlled automatic
Cab, ROPS –	Lighting system –	power shift with downshift/reverse shift
Cat Contour Series air suspension seat	Backup light	inhibitor, neutralizer during dumping,
Coat hook	Dome/courtesy light	neutral start switch, engine overspeed
Cup holder	Hazard and directional signals, LED	protection, directional shift management,
Insulated and sound-suppressed	Headlights, halogen, with dimmer	programmable top gear, body-up shift
Radio ready	Stop/tail lights, LED	limiter, economy shift mode and control
Storage compartment	Mirrors, right and left	throttle shifting
Sun visor	Power port, 24-volt	Vandalism protection locks
Tinted glass	Precleaner	Window, electric power (operator)
		Windshield wipers and washer, electric
		intermittent

773E Optional Equipment

Optional equipment may vary. Consult your Cat dealer for details.

	kg	lb		kg	lb		kg	lb
Air conditioning	90	198	Engine coolant heater	4	9	Traction Control	50	110
Automatic lube system	60	132	– 240 volt			System (TCS)		
Automatic Retarder	6	13	Exhaust diverter/	93	205	Truck Production	46	101
Control (ARC)			muffler			Management System		
Body side boards	800	1,764	Extended life brake	0	0	(TPMS)		
Body Tail end Liner	1035	2,282	Fuel heater kit	5	11	Wheel chocks	25	55
Clustered grease fittings	20	44	Integrated brake	56	123	Wiggins fast fuel	2	4
Dual slope body	9210	20,305	control			change		
Engine coolant heater	3	7	Muffler	116	256	Wiggins high-speed oil	1	2
– 120 volt			Spare rim 432 mm (17")	390	794	change		

773E Off-Highway Truck

For more complete information on Cat products, dealer services, and industry solutions, visit us on the web at www.cat.com

© 2010 Caterpillar Inc.
All rights reserved

Materials and specifications are subject to change without notice. Featured machines in photos may include additional equipment. See your Caterpillar dealer for available options.

CAT, CATERPILLAR, SAFETY.CAT.COM, their respective logos, "Caterpillar Yellow" and the "Power Edge" trade dress, as well as corporate and product identity used herein, are trademarks of Caterpillar and may not be used without permission.

AEHQ6007-02 (02-2010)
Replaces AEHQ6007-01