

# 773G

## Off-Highway Truck



### Engine (Tier 4 Final)

Engine Model	Cat® C27 ACERT™	
Gross Power – SAE J1995	578 kW	775 hp
Net Power – SAE J1349	534 kW	717 hp

### Engine (Tier 2 Equivalent)

Engine Model	Cat® C27 ACERT™	
Gross Power – SAE J1995	578 kW	775 hp
Net Power – SAE J1349	546 kW	733 hp

### Weights – Approximate (Tier 4 Final)

Maximum Gross Vehicle Weight	102 740 kg	226,503 lb
------------------------------	------------	------------

### Weights – Approximate (Tier 2 Equivalent)

Maximum Gross Vehicle Weight	102 740 kg	226,503 lb
------------------------------	------------	------------

### Operating Specifications (Tier 4 Final)

Nominal Payload Class (100%)	55.3 tonnes	61.0 tons
Maximum Working Payload (110%)	60.8 tonnes	67.0 tons
Not to Exceed Payload (120%)*	66.3 tonnes	73.1 tons
Body Capacity – SAE 2:1	35.75 m <sup>3</sup>	46.75 yd <sup>3</sup>

### Operating Specifications (Tier 2 Equivalent)

Nominal Payload Class (100%)	56.0 tonnes	61.7 tons
Maximum Working Payload (110%)	61.5 tonnes	67.8 tons
Not to Exceed Payload (120%)*	67.1 tonnes	74.0 tons
Body Capacity – SAE 2:1	35.75 m <sup>3</sup>	46.75 yd <sup>3</sup>

• Capacity with dual slope body – no liner.

\* Refer to the Caterpillar 10/10/20 Payload Guidelines for maximum gross machine weight limitations.

**G Series is our  
commitment  
to your safety,  
people and  
prosperity.**



**Contents**

Safety .....4  
Operator Work Environment .....6  
Sustainability .....8  
Cutting Your Fuel Costs .....10  
Performance .....11  
Long Term Value and Durability.....12  
Body Options.....14  
Service Convenience .....16  
Specifications.....18  
Standard Equipment.....32  
Optional Equipment.....33  
Notes.....34



***G Series represents a new era for the 773, and with your long-term success as our goal, we've developed this truck to be more productive and economical. It offers your operators the confidence, comfort and control to run at peak efficiency, and it can feed your crushers and haul material at a lower cost per ton. When you also consider its performance and fuel efficiency, the 773G is the right truck for our generation.***

# Safety

Connecting people and equipment safely



## A Focus on Personnel

The 773G is designed to minimize hazards associated with working on and around this truck.

- Ground level daily check points
- Low effort, integrated access system with hand rails for three points of contact
- Aggressive tread plate on all step areas, and lighting for after dark
- Folding windshield washing platform offers solid footing for cleaning the windshield

## Confidence and Control

Confident operators will move material quickly, efficiently and profitably.

- Brake design updates increase slope holding capability and include a brake wear indicator
- Wet disc braking for rear wheels; dry disc braking on the front
- Automatic Retarding Control for downhill grades
- New traction control system

## Visibility

The 773G supports your site safety plan with excellent visibility to the job site.

- Work Area Vision System (WAVS) is a camera system that enhances visibility behind the truck
- Lighting and mirror packages are available to suit your site conditions





### Key Features

The 773G is solidly constructed for safety.

- Rollover and Falling Object protection is part of the cab structure
- Emergency egress is available through the right-side hinged window
- Laminated glass is used in the front and left side windows
- Ground level engine shutdown for convenience and safety
- A back up alarm gives advance warning of truck movement



### Operator Safety

The 773G provides operators with full shift comfort and safety features.

- Fully adjustable and suspended seat
- Integrated three point safety belt
- A trainer's seat with lap belt facilitates on-the-job task training
- Audible warnings signal events, and fluid level monitoring is available from inside the cab
- In some instances, the truck will automatically derate engine power for safety



### Job Site Safety

- Speed limiting on the haul is new and more efficient than gear limiting
- Secondary steering in the event of power loss
- Speed limiting during body up operations



## Comfort

The comfort of your crew will contribute to their productivity and awareness on the job.

- Easy, low effort access to the cab
- Ergonomic, intuitive controls
- Left side power window
- Automatic temperature control inside the cab
- Throttle lock convenience for long uphill climbs
- The cab is spacious with window area that supports visibility
- An integrated footrest provides comfort and support
- Sound suppression provides a quieter work environment
- The cab is isolation mounted reducing noise and vibration
- Lighting package options to meet operation needs
- Automotive quality shifting from new APECS transmission controls

## Confidence and Control

Strong, predictable performance will help your operators achieve the lowest cost per ton.

- Automatic Retarding Control reduces operator effort and controls braking on downhill grades
- Performance and health information at a glance using well lit gauges and the Advisor Message Display
- Steering performance from a design that maintains tire alignment
- Stopping power from fade-resistant brakes – purpose built for off road applications and the loads carried by the 773G
- Traction control is now steering sensitive and uses the service brakes to control wheel slip. The result: faster activation and improved response to wheel slip
- Visibility is excellent with extensive mirror options, large window areas

*Cab layout subject to change with optional equipment.*



# Operator Work Environment

Productivity from comfort, confidence, control



## Information

The Advisor display and VIMS™ software are important reporting tools that help you analyze:

- Productivity, haul road efficiency, operator skill
- Fuel use, cycle times, idle time
- Machine health and events



As you work for a more sustainable business model, the Cat® 773G can contribute in more ways than one.

### Fuel and Emissions

- There are multiple fuel saving strategies on the 773G, two are economy modes that are adjustable to meet your unique production needs
- For the U.S., Tier 4 Final emission controls are conveniently low maintenance and are transparent to the operation of the truck

### Sound

- Operator noise is reduced by 50% using sound suppression technology in the cab
- A rubber liner option for truck bodies reduces noise levels for both the operator and spectators

### Component Life

- Cat Reman parts are an economical alternative to new
- You can extend tire life using TKPH/TMPH, a feature that calculates tire loading
- Castings and box section frame construction absorb shocks and distribute loads
- A new rear axle housing holds new, robust differential gears that compliment the power and torque increases of the truck
- Hydraulic oil filter life is extended to 1,000 hours under normal conditions
- Autostall enables quick operating temperatures for best performance and life
- Delayed engine shutdown prevents hot shutdowns that can reduce component life



### Tier 4 Final

Caterpillar's simple solution is transparent to your operators, controls emissions and increases fuel efficiency.

- Two engine-mounted diesel oxidation catalyst canisters control particulate matter
- Our NRS Technology replaces a portion of intake air with exhaust gas to control combustion temperatures and  $\text{No}_x$  production
- Precise, extremely fine atomization of fuel under all load conditions



# Sustainability

The benefits are far reaching and economical



# Cutting Your Fuel Costs

A strategy for lowering your cost per ton



The 773G introduces several key fuel conservation features:

- **Auto Neutral Idle** – as the 773G idles in a forward gear, the transmission will automatically slip in and out of a neutral state to avoid stalling the torque converter and increasing fuel consumption.
- **Engine Idle Shutdown** – when your G Series truck is in park and idles for more than a preset time, the truck will initiate engine shutdown to conserve fuel. This feature can be time adjusted or turned on or off according to your specific needs.
- **Speed Limiting** – while you can continue to gear limit your G Series trucks, Caterpillar offers speed limiting that allows the truck to travel at a more fuel efficient engine speed and gear selection.
- **Transmission Controls** – New APECS transmission controls increase fuel efficiency by maintaining momentum and speed on grade.

## Economy Modes

- **Standard Economy Mode** – G Series has the ability to adjust engine power based on your site, fleet and economic conditions. You can manually control fuel burn by adjusting the power down between 0.5 and 15 percent.
- **Adaptive Economy Mode** – New for G Series – this economy mode requires a baseline for production from you using the Advisor display. As the truck transits the haul cycle, it is constantly evaluating its ability to meet your baseline in a reduced power setting. Where full power is needed, full power is applied, where reduced power works, reduced power is applied. It's fully automatic with no special operation required.



# Performance

## Efficient application of power and technology

The 773G will haul your material faster and more efficiently with increases in power and new APECS transmission controls.

- A 5% increase in power improves cycle times and grade climbing performance
- New APECS transmission controls carry more torque through the shifts, producing faster cycle times and the possibility of climbing grades in a higher gear



### Traction Control

G Series introduces benefits to your fleet when running in wet conditions by introducing a more responsive traction controls system.

- The system is steering sensitive to determine slip from high speed turns
- The system engages at slower speeds returning traction sooner
- The system engages sooner in the slip, potentially reducing tire wear
- The system modulates instantly between the two wheel groups for control
- Using the hydraulic service brakes facilitates the instant modulation and responsiveness

At Caterpillar, we know that our truck is critical to your business, that's why we use industry leading technology to ensure maximum machine availability and reliability.

### **Structural Strength**

The backbone of the 773G is its frame. Our frames are designed for off-road integrity and more than one life cycle. The 773G, with its new power and performance increases, has updated final drive gears and a new rear axle housing to support this new level of work.

- Caterpillar strategically applies castings with box section construction to manage off-road stresses
- A new front frame design increases the approach angle on ramps and grades
- New heavy duty gears compliment the updates in power and torque
- A new robust rear axle housing also supports the truck's performance

### **Suspension**

- Front struts use our proven king pin design for effective absorption of haul road shocks
- Rear suspension cylinders have been inverted to minimize contamination

### **Planetary Powershift Transmission with APECS Controls**

New APECS controls improve performance with the following:

- Torque shift management – allows the truck to power through shift points
- Part throttle shifting – provides an exceptionally smooth ride
- ECPC – electronically controls clutch pressures for long life

### **Cat C27 ACERT**

- 5% more power gives the truck new performance levels and quick haul cycles
- Cat MEUI™ injectors provide high pressure, fine atomization under all load conditions for fuel efficiency and responsiveness
- Low pressure fuel lines from the tank to the engine simplify service
- The C27 is carefully balanced with vibration controls that reduce noise and protect against unnecessary harmonics
- Cooling is provided by either a demand fan (standard for Tier 4 Final machines) or a conventional cooling fan
- Ground level engine shutdown switch for safety
- Excellent high-altitude capability (see specifications for details)

### **Steering**

- The steering linkage is designed to provide feedback to the operator
- The Cat king pin front suspension system maintains steering tolerances and tire alignment



# Long Term Value and Durability

Proven components for reliable performance

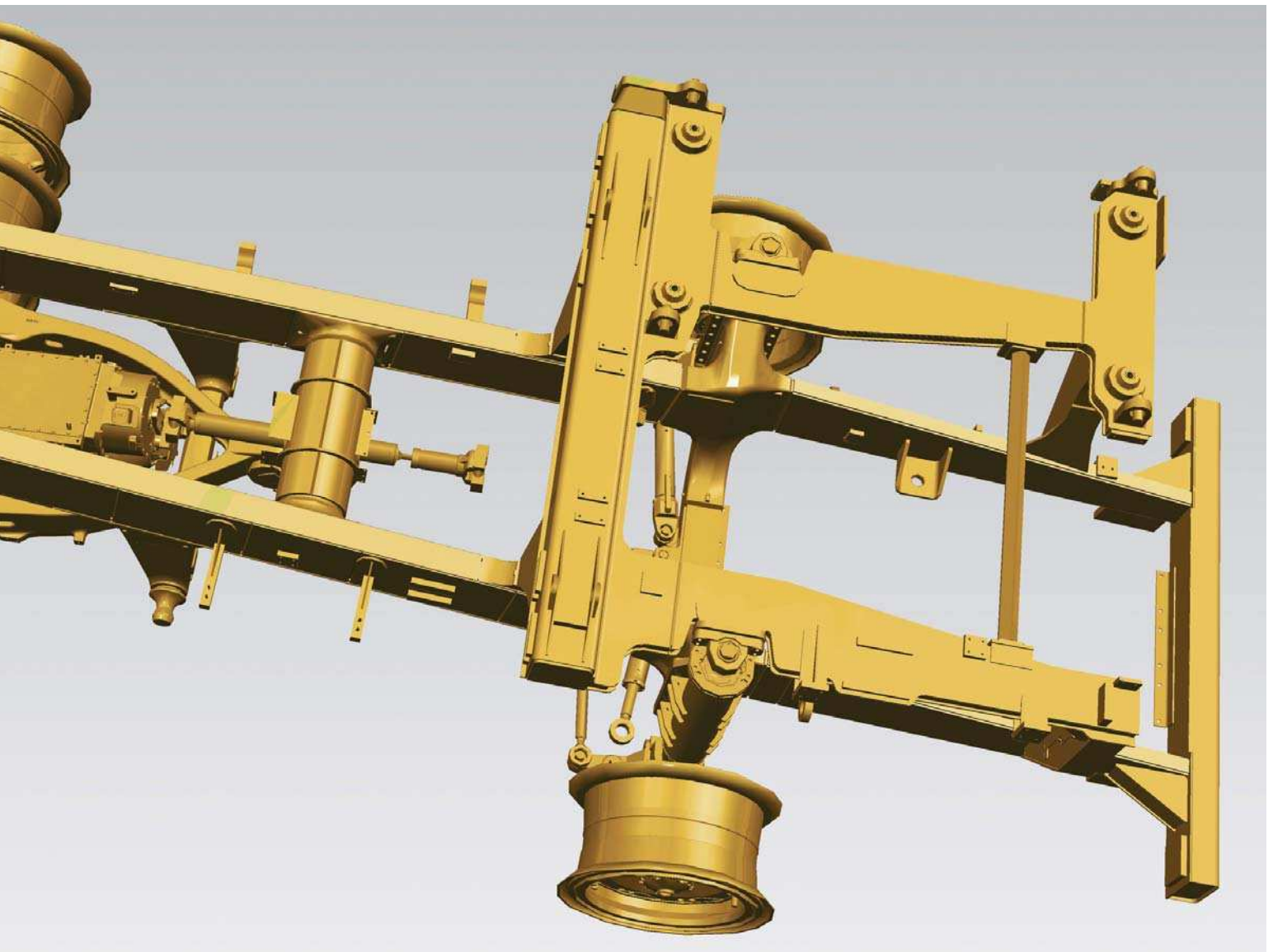

## Brake Performance

Cat trucks provide powerful, fade-resistant braking for off road applications, and G Series introduces new ways to extend your brake life.

- Rear brakes are wet disc while the front are dry, caliper type
- Slope holding capability benefits from all wheel parking brake actuation
- Brake life can be extended by choosing the optional Cat Engine Brake
- Additional springs in the design reduce wear and increase service life
- A brake wear indicator keeps you informed of maintenance timing
- Extended life brake material is available for extreme applications



Our truck bodies are engineered to compliment the chassis and built to haul your material for years of trouble-free performance. In fact, Cat truck bodies are designed to let the truck perform at peak efficiency by correctly centering and distributing the load. Outfitting your truck body with a steel or rubber liner may be advisable based on material type and application. If you have questions about body selection or applying liners, your Cat dealer has the tools and knowledge to help you with this decision process.

### **The Rubber Liner**

This important factory-installed option will prolong body life in hard rock applications.

- Available for the dual slope and flat floor bodies
- It will reduce shock loading for both the operator and truck
- It absorbs noise, reducing both spectator and operator sound levels
- The rubber liner is not a good option for wet, sticky material
- The rubber liner should not be used with our body heat option

### **Side Boards**

In the event that your material is light weight, we offer factory-installed 150 mm (6 in) sideboards to help you achieve rated capacities.

You can use our “Body Selection Guide” as a reference for selecting the correct body type and liner package. Cat dealers can order this document using reference number AEXQ0673.

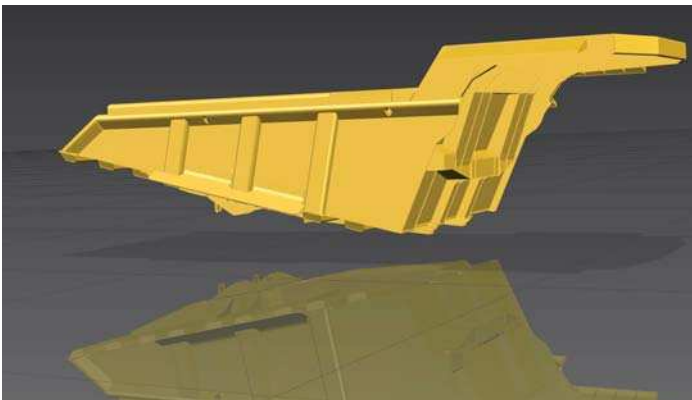
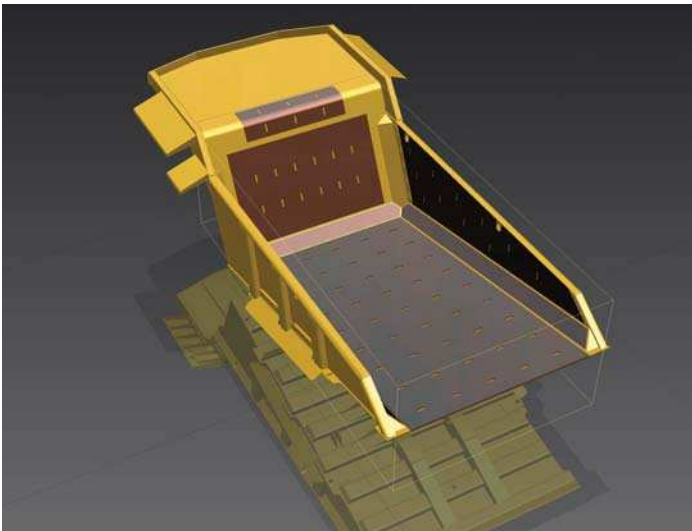

# Body Options

For your applications and material types



## Dual Slope Body

If your haul profile includes steep slopes, the dual slope body offers excellent material retention.

- The dual slope has a SAE 2:1 heaped capacity of 35.20 m<sup>3</sup> (46 yd<sup>3</sup>) with a steel liner configuration
- 400 BNH steel on interior surfaces offers excellent wear characteristics
- Material is carried low and centered for stability
- A single 16 mm (0.62 in) steel liner option is available for this body
- A single rubber liner is available for this body

## Flat Floor Body

If you're feeding a crusher, the flat floor body is an excellent choice for metering material.

- The flat floor body also offers excellent material retention and stability
- 400 BNH steel is used on internal surfaces for wear protection
- A single steel liner option is available
- A rubber liner is also available for this body

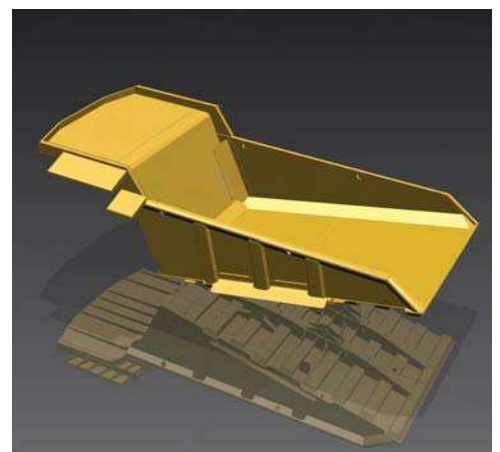
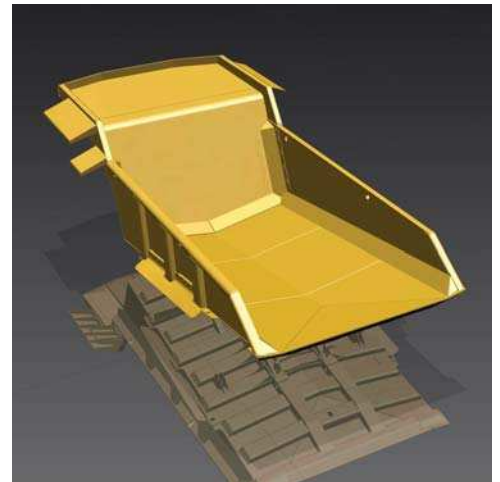

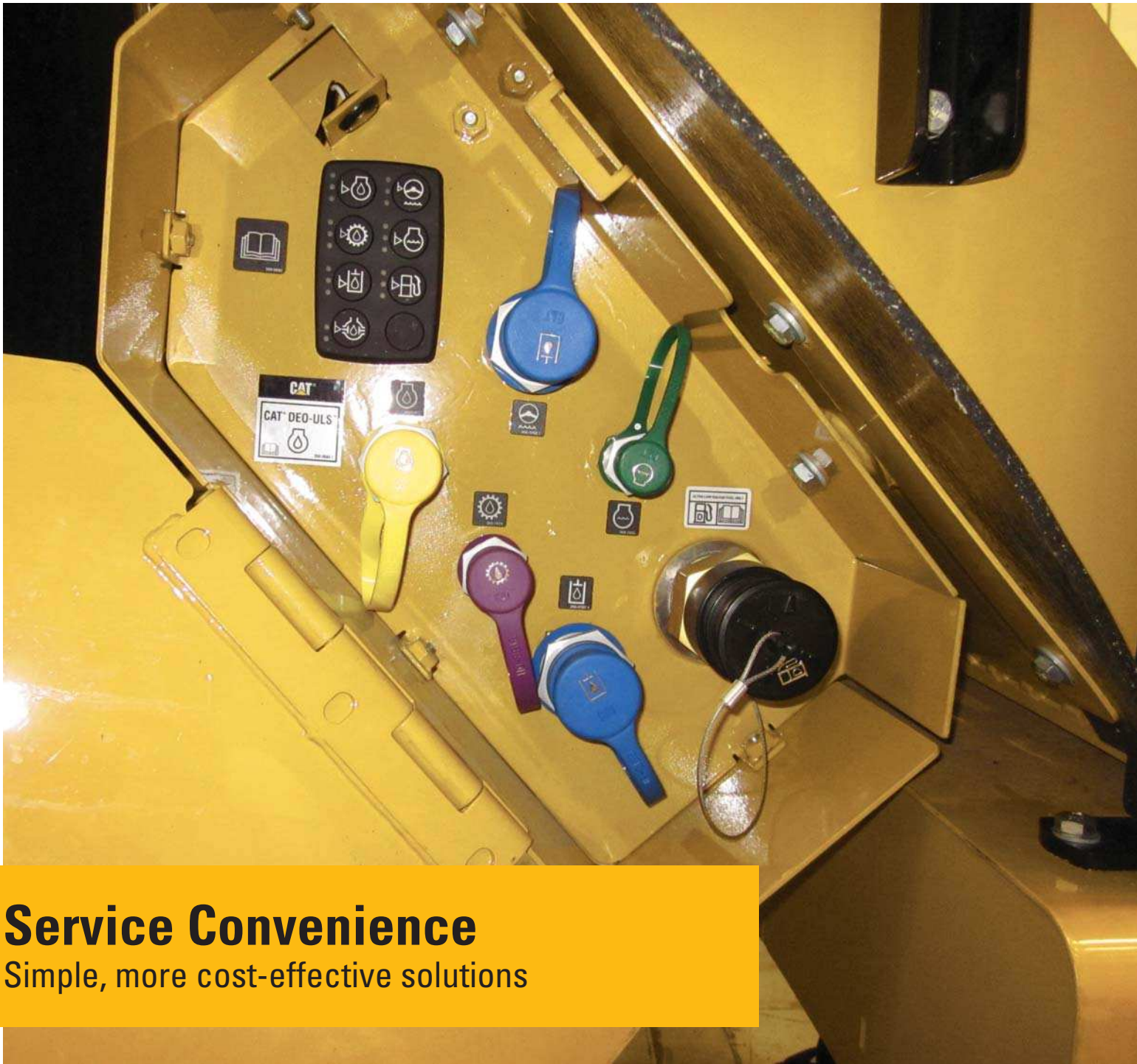

## Service Convenience

Simple, more cost-effective solutions

### Service Centers – Fluid Fill

You will save both time and money using the optional fluid fill service center.

- Fill and extraction for all fluids in one location
- Key pad indicates existing fluid levels
- Includes all oils, coolant and fuel
- Conveniently located at ground level
- Lighted for night time use



## Service Centers – Electrical Connections

This bumper-mounted electrical service center provides the convenience and safety of ground level access to important service tasks.

- Ground level access to VIMS data
- Ground level access to an ET port
- Includes a master disconnect switch
- Engine lockout switch
- Hydraulics lockout switch
- Breaker access

## Brake Monitoring

G Series introduces updates that will increase the life of your brakes.

- A brake wear indicator is new and standard
- Design improvements are increasing separation forces to lessen wear and increase brake life

## Filter Life

- With all new hydraulic system efficiency, your filter life is extended to 1,000 hours
- Cab air filter life can also be extended with the optional cab precleaner.
- Our engine oil filters are improved, and in some cases extending life beyond 500 hours



## Product Link™

For comprehensive fleet management, Caterpillar offers Product Link solutions. This solution is a combination of machine-mounted hardware and software called Vision Link. You can access fleet information either through cellular or satellite channels. These channels may be restricted and unavailable in some countries.

Customers who use Product Link are remotely monitoring machine health and organizing service requirements.

# 773G Off-Highway Truck Specifications

## Engine (Tier 4 Final)

Engine Model	Cat C27 ACERT	
Rated Engine Speed	1,800 rpm	
Gross Power – SAE J1995	578 kW	775 hp
Net Power – SAE J1349	534 kW	717 hp
Net Power – ISO 9249	540 kW	724 hp
Net Power – 80/1269/EEC	540 kW	724 hp
Engine Power – ISO 14396	568 kW	762 hp
Peak Torque Speed	1,200 rpm	
Net Torque	3992 N·m	2,944 lb-ft
Bore	137 mm	5.4 in
Stroke	152 mm	6 in
Displacement	27 L	1,648 in <sup>3</sup>

## Engine (Tier 2 Equivalent)

Engine Model	Cat C27 ACERT	
Rated Engine Speed	2,000 rpm	
Gross Power – SAE J1995	578 kW	775 hp
Net Power – SAE J1349	546 kW	733 hp
Net Power – ISO 9249	552 kW	741 hp
Net Power – 80/1269/EEC	552 kW	741 hp
Engine Power – ISO 14396	569 kW	763 hp
Peak Torque Speed	1,300 rpm	
Net Torque	3646 N·m	2,689 lb-ft
Bore	137 mm	5.4 in
Stroke	152 mm	6 in
Displacement	27 L	1,648 in <sup>3</sup>

- Power rating applies at 2,000 rpm when tested under the specified condition for the specified standard.
- Ratings based on SAE J1995 standard air conditions of 25° C (77° F) and 100 kPa (29.61 Hg) barometer. Power based on fuel having API gravity of 35 at 16° C (60° F) and an LHV of 42 780 kJ/kg (18,390 BTU/lb) when engine used at 30° C (86° F).
- No engine derating required up to 3048 m (10,000 ft) for Tier 4 Final and 3810 m (12,500 ft) for Tier 2 Equivalent.
- Not regulated under EU Stage IV regulations due to power rating above 560 kW (750 hp).

## Transmission (Tier 4 Final)

Forward 1	10.6 km/h	6.6 mph
Forward 2	15.0 km/h	9.3 mph
Forward 3	20.3 km/h	12.6 mph
Forward 4	27.0 km/h	16.8 mph
Forward 5	36.7 km/h	22.8 mph
Forward 6	49.4 km/h	30.7 mph
Forward 7	66.9 km/h	41.6 mph
Reverse	14.0 km/h	8.7 mph

## Transmission (Tier 2 Equivalent)

Forward 1	10.8 km/h	6.7 mph
Forward 2	15.1 km/h	9.4 mph
Forward 3	20.4 km/h	12.7 mph
Forward 4	27.4 km/h	17.0 mph
Forward 5	37.0 km/h	23.0 mph
Forward 6	50.1 km/h	31.1 mph
Forward 7	67.6 km/h	42.0 mph
Reverse	14.1 km/h	8.8 mph

- Maximum travel speeds with standard 24.00R35 (E4) tires.

## Final Drives

Differential Ratio	3.64:1
Planetary Ratio	4.80:1
Total Reduction Ratio	17.49:1

## Brakes

Brake Surface – Front	655 cm <sup>2</sup>	257 in <sup>2</sup>
Brake Surface – Rear	61 269 cm <sup>2</sup>	9,497 in <sup>2</sup>
Brake Standards	ISO 3450:1996	

## Body Hoists (Tier 4 Final)

Pump Flow – High Idle	448 L/min	118 gal/min
Relief Valve Setting – Raise	17 250 kPa	2,502 psi
Relief Valve Setting – Lower	3450 kPa	500 psi
Body Raise Time – High Idle	10.0 seconds	
Body Lower Time – Float	14.0 seconds	
Body Power Down – High Idle	14.0 seconds	

### Body Hoists (Tier 2 Equivalent)

Pump Flow – High Idle	448 L/min	118 gal/min
Relief Valve Setting – Raise	17 250 kPa	2,502 psi
Relief Valve Setting – Lower	3450 kPa	500 psi
Body Raise Time – High Idle	9.5 seconds	
Body Lower Time – Float	13.0 seconds	
Body Power Down – High Idle	13.0 seconds	

### Capacity – Dual Slope – 100% Fill Factor

Struck	26.86 m <sup>3</sup>	35.13 yd <sup>3</sup>
Heaped 2:1 (SAE)	35.75 m <sup>3</sup>	46.76 yd <sup>3</sup>

### Capacity – Flat Floor – 100% Fill Factor

Struck	26.25 m <sup>3</sup>	34.33 yd <sup>3</sup>
Heaped 2:1 (SAE)	35.49 m <sup>3</sup>	46.41 yd <sup>3</sup>

### Weight Distributions – Approximate

Front Axle – Empty	53%
Front Axle – Loaded	35%
Rear Axle – Empty	47%
Rear Axle – Loaded	65%

### Suspension

Empty Loaded Cylinder Stroke Front	234 mm	9.2 in
Empty Loaded Cylinder Stroke Rear	149 mm	5.8 in
Rear Axle Oscillation	8.1°	

### Sound

#### Sound Standards

- The operator Equivalent Sound Pressure Level (Leq) is 76 dB(A) when SAE J1166 FEB2008 is used to measure the value for an enclosed cab. This is a work cycle sound exposure level. The cab was properly installed and maintained. The test was conducted with the cab doors and the cab windows closed.
- The exterior sound pressure level for the standard machine measured at a distance of 15 m (49 ft) according to the test procedures specified in SAE J88:2008, mid-gear moving operation is 86 dB(A).
- Hearing protection may be needed when operating with an open operator station and cab (when not properly maintained or doors/windows open) for extended periods or in a noisy environment.

### Service Refill Capacities

Fuel Tank	795 L	210 gal
Cooling System	171 L	45 gal
Crankcase	90 L	24 gal
Differentials and Final Drives	145 L	38 gal
Steering Tank	36 L	9.5 gal
Steering System (includes tank)	54 L	14 gal
Brake/Hoist Hydraulic Tank	176 L	46.5 gal
Brake Hoist System	322 L	85 gal
Torque Converter/Transmission System HRC	70 L	18 gal
Torque Converter/Transmission System LRC	61 L	16 gal

### Steering

Steering Standards	SAE J1511 FEB94 ISO 5010:1992	
Steer Angle	31°	
Turning Diameter – Front	23.5 m	77 ft 1 in
Turning Circle Clearance Diameter	26.1 m	85 ft 8 in

### Tires

Standard Tire	24.00R35 (E4)
---------------	---------------

- Productive capabilities of the 773G truck are such that, under certain job conditions, TKPH (TMPH) capabilities of standard or optional tires could be exceeded and, therefore, limit production.
- Caterpillar recommends the customer evaluate all job conditions and consult the tire manufacturer for proper tire selection.

### ROPS

#### ROPS/FOPS Standards

- ROPS (Rollover Protective Structure) for cab offered by Caterpillar meets ISO 3471:2008 ROPS criteria.
- FOPS (Falling Objects Protective Structure) meets ISO 3449:2005 Level II FOPS criteria.

# 773G Off-Highway Truck Specifications

## Weight/Payload Calculation – Tier 4 Final Examples

<b>773G – Flat Floor</b>		<b>354-7800 Base Body</b>	<b>377-6300 Base Body/Liner</b>	<b>377-6302 Rubber Liner</b>
<b>Floor/Sidewall/Frontwall</b>	mm (in)	<b>20/10/12 (0.79/0.39/0.47)</b>	<b>36/18/22 (1.42/0.71/0.87)</b>	<b>102/8/8 + 20/10/12 (4.0/0.31/0.31) + (0.79/0.39/0.47)</b>
<b>Payload Capacity</b>	m <sup>3</sup> (yd <sup>3</sup> )	<b>35.5 (46.4)</b>	<b>35.0 (45.8)</b>	<b>33.3 (43.6)</b>
	mm (in)	<b>20 (0.787)</b>	<b>36 (1.42)</b>	<b>102 (4.0)</b>
Target Gross Machine Weight	kg (lb)	102 740 (226,503)	102 740 (226,503)	102 740 (226,503)
Empty Chassis Weight	kg (lb)	34 522 (76,107)	34 522 (76,107)	34 522 (76,107)
Body System Weight	kg (lb)	11 423 (25,183)	15 217 (33,547)	15 997 (35,267)
Empty Machine Weight	kg (lb)	45 945 (101,290)	49 739 (109,654)	50 519 (111,374)
<b>Attachments</b>				
Fuel Tank Size	L (gal)	795 (210)	795 (210)	795 (210)
Fuel Tank – 100% Fill	kg (lb)	669 (1,474)	669 (1,474)	669 (1,474)
Empty Operating Weight**	kg (lb)	46 614 (102,764)	50 407 (111,128)	51 188 (112,848)
Target Payload*	kg (lb)	56 126 (123,739)	52 333 (115,375)	51 552 (113,655)
Target Payload*	tonnes (tons)	56.1 (61.9)	52.3 (57.7)	51.6 (56.8)
<b>10/10/20 Policy*</b>				
Target Payload – 100%	kg (lb)	56 126 (123,739)	52 333 (115,375)	51 552 (113,655)
Target Payload – 110%	kg (lb)	61 739 (136,112)	57 566 (126,912)	56 708 (125,020)
Target Payload – 120%	kg (lb)	67 352 (148,486)	62 799 (138,449)	61 863 (136,385)
Maximum Gross Machine Weight*	kg (lb)	113 965 (251,251)	113 207 (249,578)	113 050 (249,234)
<b>773G – Dual Slope</b>				
		<b>354-7810 Base Body</b>	<b>377-6310 Base Body/Liner</b>	<b>No Rubber Liner Offered</b>
<b>Floor/Sidewall/Frontwall</b>	mm (in)	<b>20/10/12 (0.79/0.39/0.47)</b>	<b>36/18/22 (1.42/0.71/0.87)</b>	
<b>Payload Capacity</b>	m <sup>3</sup> (yd <sup>3</sup> )	<b>35.8 (46.8)</b>	<b>35.2 (46.0)</b>	
	mm (in)	<b>20 (0.787)</b>	<b>36 (1.42)</b>	
Target Gross Machine Weight	kg (lb)	102 740 (226,503)	102 740 (226,503)	
Empty Chassis Weight	kg (lb)	34 522 (76,107)	34 522 (76,107)	
Body System Weight	kg (lb)	11 049 (24,358)	14 776 (32,575)	
Empty Machine Weight	kg (lb)	45 570 (100,464)	49 298 (108,683)	
<b>Attachments</b>				
Fuel Tank Size	L (gal)	795 (210)	795 (210)	
Fuel Tank – 100% Fill	kg (lb)	669 (1,474)	669 (1,474)	
Empty Operating Weight**	kg (lb)	46 239 (101,939)	49 967 (110,158)	
Target Payload*	kg (lb)	56 501 (124,564)	52 773 (116,345)	
Target Payload*	tonnes (tons)	56.5 (62.3)	52.8 (58.2)	
<b>10/10/20 Policy*</b>				
Target Payload – 100%	kg (lb)	56 501 (124,564)	52 773 (116,345)	
Target Payload – 110%	kg (lb)	62 152 (137,020)	58 051 (127,980)	
Target Payload – 120%	kg (lb)	67 802 (149,477)	63 328 (139,614)	
Maximum Gross Machine Weight*	kg (lb)	114 040 (251,416)	113 295 (249,772)	

\*Refer to Caterpillar 10/10/20 overload policy.

\*\*Includes weight of all attachments.

## Weight/Payload Calculation – Tier 2 Equivalent Examples

<b>773G – Flat Floor</b>		<b>354-7800 Base Body</b>	<b>377-6300 Base Body/Liner</b>	<b>377-6302 Rubber Liner</b>
<b>Floor/Sidewall/Frontwall</b>	mm (in)	<b>20/10/12 (0.79/0.39/0.47)</b>	<b>36/18/22 (1.42/0.71/0.87)</b>	<b>102/8/8 + 20/10/12 (4.0/0.31/0.31) + (0.79/0.39/0.47)</b>
<b>Payload Capacity</b>	m <sup>3</sup> (yd <sup>3</sup> )	<b>35.5 (46.4)</b>	<b>35.0 (45.8)</b>	<b>33.3 (43.6)</b>
	mm (in)	<b>20 (0.787)</b>	<b>36 (1.42)</b>	<b>102 (4.0)</b>
Target Gross Machine Weight	kg (lb)	102 740 (226,503)	102 740 (226,503)	102 740 (226,503)
Empty Chassis Weight	kg (lb)	33 867 (74,663)	33 867 (74,663)	33 867 (74,663)
Body System Weight	kg (lb)	11 423 (25,183)	15 217 (33,547)	15 997 (35,267)
Empty Machine Weight	kg (lb)	45 290 (99,846)	49 084 (108,210)	49 864 (109,930)
<b>Attachments</b>				
Fuel Tank Size	L (gal)	795 (210)	795 (210)	795 (210)
Fuel Tank – 100% Fill	kg (lb)	669 (1,474)	669 (1,474)	669 (1,474)
Empty Operating Weight**	kg (lb)	45 959 (101,322)	49 752 (109,684)	50 533 (111,406)
Target Payload*	kg (lb)	56 781 (125,181)	52 988 (116,819)	52 207 (115,097)
Target Payload*	tonnes (tons)	56.8 (62.6)	53.0 (58.4)	52.2 (57.5)
<b>10/10/20 Policy*</b>				
Target Payload – 100%	kg (lb)	56 781 (125,181)	52 988 (116,819)	52 207 (115,097)
Target Payload – 110%	kg (lb)	62 460 (137,699)	58 287 (128,500)	57 428 (126,607)
Target Payload – 120%	kg (lb)	68 138 (150,217)	63 585 (140,182)	62 649 (138,116)
Maximum Gross Machine Weight*	kg (lb)	114 096 (251,539)	113 338 (249,867)	113 181 (249,522)
<b>773G – Dual Slope</b>				
		<b>354-7810 Base Body</b>	<b>377-6310 Base Body/Liner</b>	<b>No Rubber Liner Offered</b>
<b>Floor/Sidewall/Frontwall</b>	mm (in)	<b>20/10/12 (0.79/0.39/0.47)</b>	<b>36/18/22 (1.42/0.71/0.87)</b>	
<b>Payload Capacity</b>	m <sup>3</sup> (yd <sup>3</sup> )	<b>35.8 (46.8)</b>	<b>35.2 (46.0)</b>	
	mm (in)	<b>20 (0.787)</b>	<b>36 (1.42)</b>	
Target Gross Machine Weight	kg (lb)	102 740 (226,503)	102 740 (226,503)	
Empty Chassis Weight	kg (lb)	33 867 (74,663)	33 867 (74,663)	
Body System Weight	kg (lb)	11 049 (24,358)	14 776 (32,575)	
Empty Machine Weight	kg (lb)	44 916 (99,022)	48 643 (107,239)	
<b>Attachments</b>				
Fuel Tank Size	L (gal)	795 (210)	795 (210)	
Fuel Tank – 100% Fill	kg (lb)	669 (1,474)	669 (1,474)	
Empty Operating Weight**	kg (lb)	45 585 (100,497)	49 312 (108,714)	
Target Payload*	kg (lb)	57 155 (126,006)	53 428 (117,789)	
Target Payload*	tonnes (tons)	57.2 (63.0)	53.4 (58.9)	
<b>10/10/20 Policy*</b>				
Target Payload – 100%	kg (lb)	57 155 (126,006)	53 428 (117,789)	
Target Payload – 110%	kg (lb)	62 871 (138,607)	58 771 (129,568)	
Target Payload – 120%	kg (lb)	68 586 (151,207)	64 114 (141,347)	
Maximum Gross Machine Weight*	kg (lb)	114 171 (251,704)	113 426 (250,061)	

\*Refer to Caterpillar 10/10/20 overload policy.

\*\*Includes weight of all attachments.

# 773G Off-Highway Truck Specifications

## 10/10/20 Payload Management Policy for Optimal Machine Life

The ideal hauling strategy that maximizes machine and machine component life is to *keep the mean of all payloads at or below the machine's rated target payload.*

- 90% of loads should fall into this range
- No more than 10% of loads should exceed 10% of the target payload
- No loads should be above 20% of the target payload

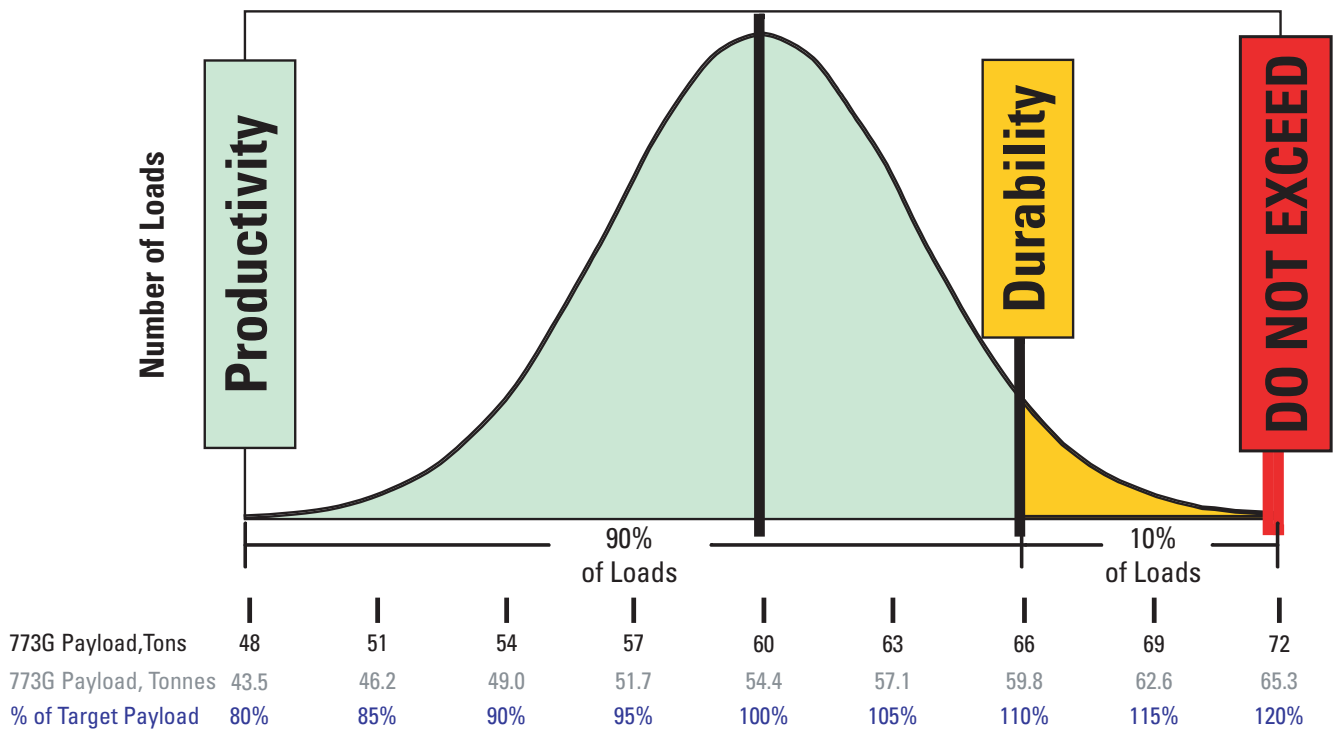

## Dimensions

All dimensions are approximate.

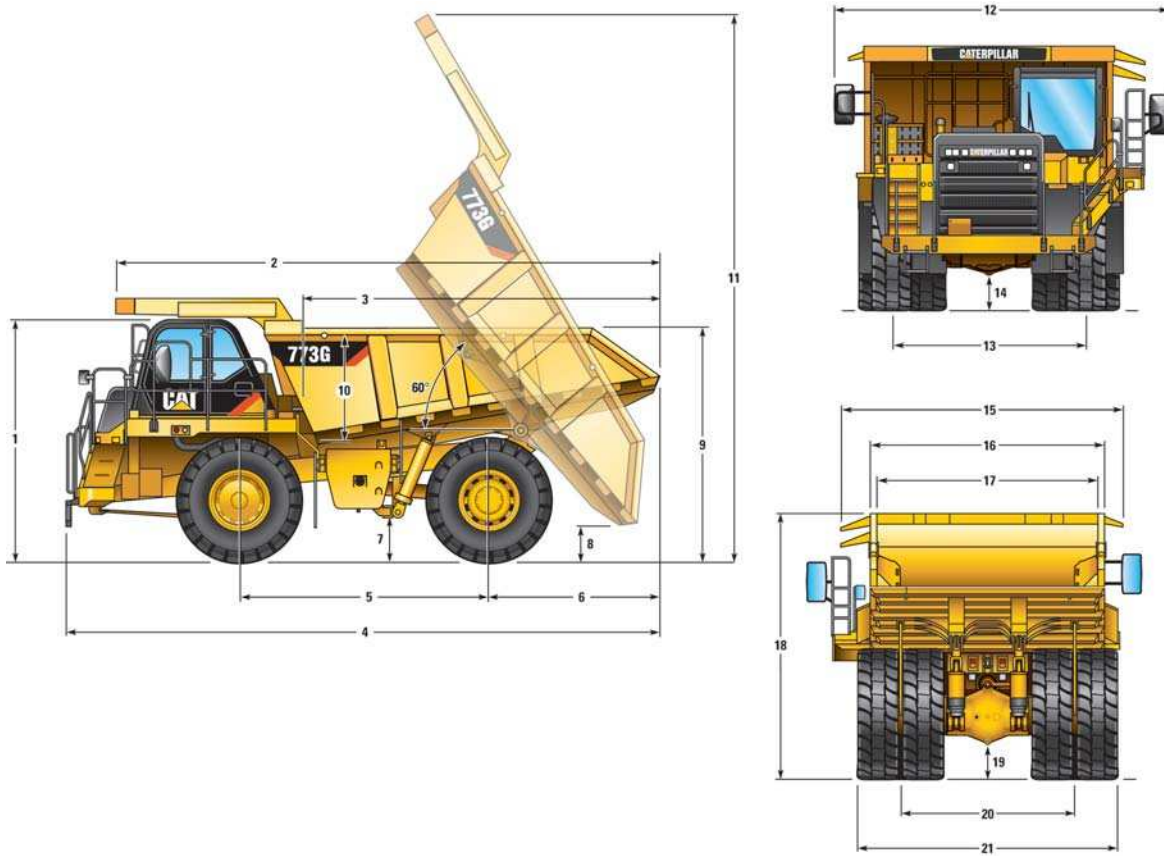

	Dual Slope		Flat Floor	
<b>1</b> Height to Top of ROPS	4108 mm	13.48 ft	4108 mm	13.48 ft
<b>2</b> Overall Body Length	9216 mm	30.24 ft	9293 mm	30.49 ft
<b>3</b> Inside Body Length	6100 mm	20.01 ft	6100 mm	20.01 ft
<b>4</b> Overall Length	10 070 mm	33.04 ft	10 146 mm	33.29 ft
<b>5</b> Wheelbase	4215 mm	13.83 ft	4215 mm	13.83 ft
<b>6</b> Rear Axle to Tail	2925 mm	9.60 ft	3006 mm	9.86 ft
<b>7</b> Ground Clearance	759 mm	2.49 ft	759 mm	2.49 ft
<b>8</b> Dump Clearance	639 mm	2.10 ft	640 mm	2.10 ft
<b>9</b> Loading Height – Empty	3771 mm	12.37 ft	3771 mm	12.37 ft
<b>10</b> Inside Body Depth – Maximum	1773 mm	5.82 ft	1727 mm	5.67 ft
<b>11</b> Overall Height – Body Raised	9284 mm	30.46 ft	9280 mm	30.45 ft
<b>12</b> Operating Width	5673 mm	18.61 ft	5673 mm	18.61 ft
<b>13</b> Centerline Front Tire Width	3205 mm	10.52 ft	3205 mm	10.52 ft
<b>14</b> Engine Guard Clearance	703 mm	2.31 ft	703 mm	2.31 ft
<b>15</b> Overall Canopy Width	4886 mm	16.03 ft	4886 mm	16.03 ft
<b>16</b> Outside Body Width	3922 mm	12.87 ft	3922 mm	12.87 ft
<b>17</b> Inside Body Width	3654 mm	11.99 ft	3654 mm	11.99 ft
<b>18</b> Front Canopy Height	4459 mm	14.63 ft	4459 mm	14.63 ft
<b>19</b> Rear Axle Clearance	560 mm	1.84 ft	560 mm	1.84 ft
<b>20</b> Centerline Rear Dual Tire Width	2929 mm	9.61 ft	2929 mm	9.61 ft
<b>21</b> Overall Tire Width	4411 mm	14.47 ft	4411 mm	14.47 ft

# 773G Off-Highway Truck Specifications

## Retarding Performance (Tier 4 Final)

To determine retarding performance: Add lengths of all downhill segments and, using this total, refer to proper retarding chart. Read from gross weight down to the percent effective grade. Effective grade equals actual % grade minus 1% for each 10 kg/t (20 lb/ton) of rolling resistance. From this weight-effective grade point, read horizontally to the curve with the highest obtainable gear, then down to maximum descent speed brakes can properly handle without exceeding cooling capacity. The following charts are based on these conditions: 32° C (90° F) ambient temperature, at sea level, with 24.00R35 (E4) tires.

**NOTE:** Select the proper gear to maintain engine rpm at the highest possible level, without overspeeding the engine. If cooling oil overheats, reduce ground speed to allow transmission to shift to the next lower speed range.

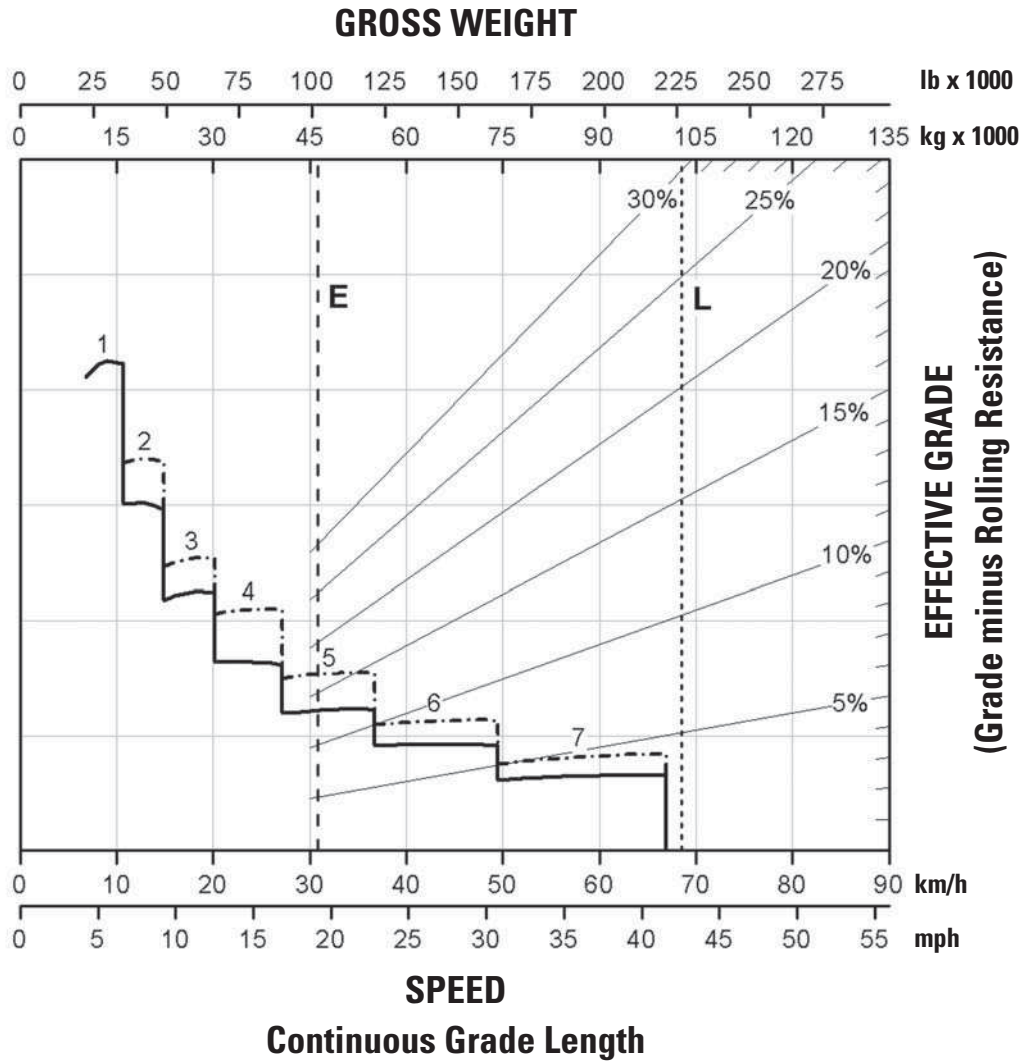



# Retarding Performance (Tier 4 Final)

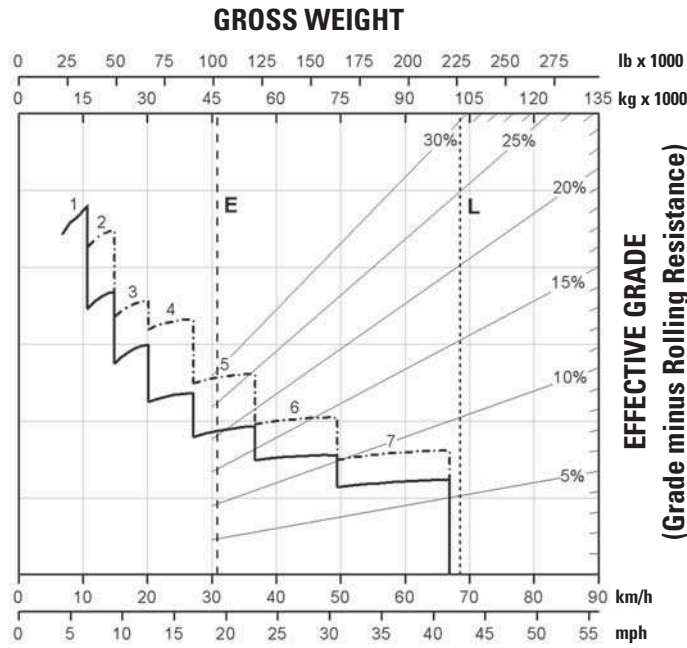

Grade Distance – 450 m (1,500 ft)

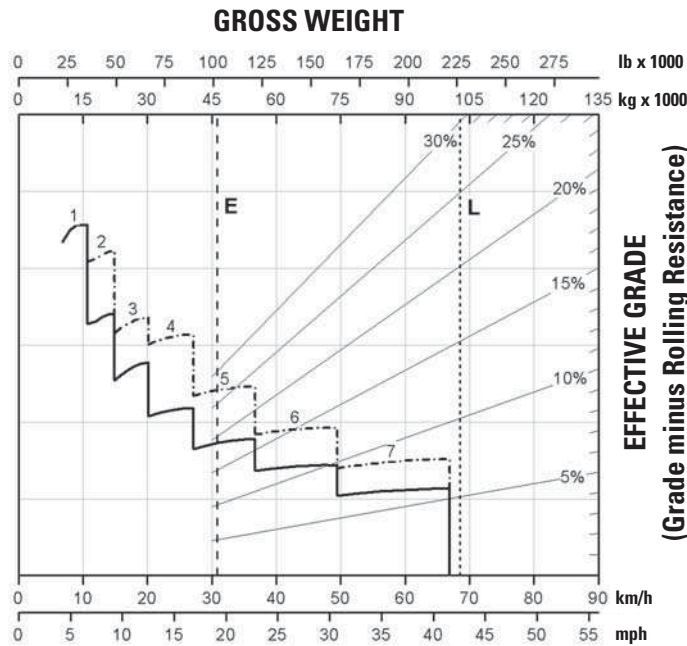

Grade Distance – 600 m (2,000 ft)

- with ARC only
- - - - - ARC and Engine Brake
- E – Typical Field Empty Weight
- L – Target Gross Machine Operating Weight 102 739 kg (226,500 lb)

# 773G Off-Highway Truck Specifications

## Retarding Performance (Tier 4 Final)

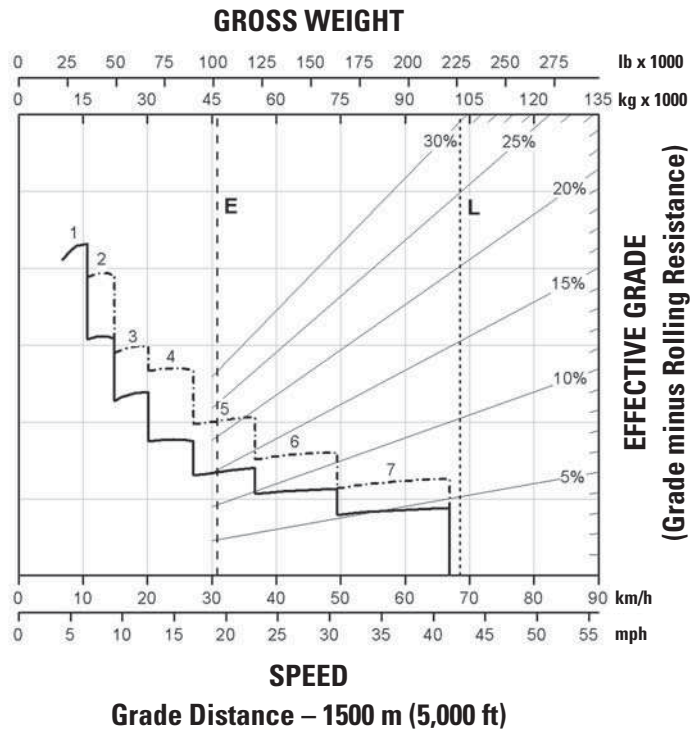
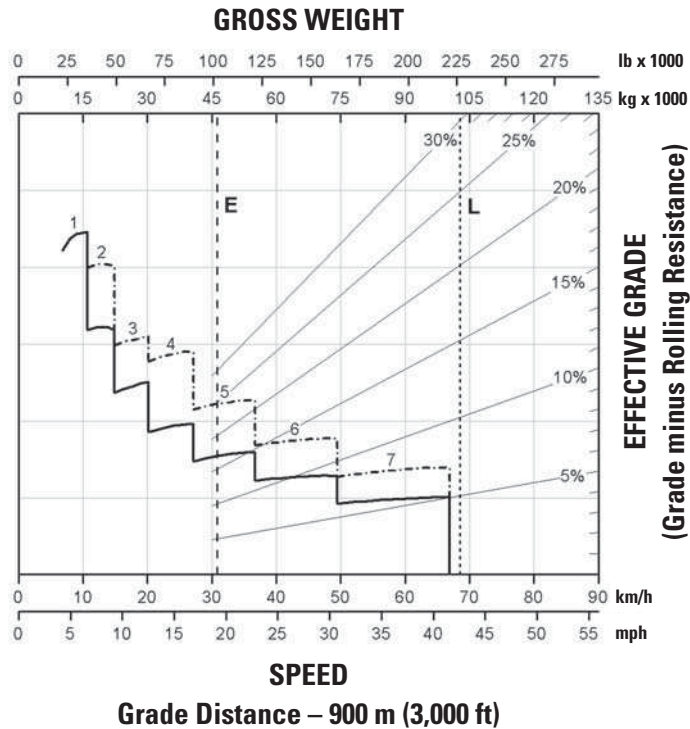

- with ARC only
- - - - - ARC and Engine Brake
- E – Typical Field Empty Weight
- L – Target Gross Machine Operating Weight 102 739 kg (226,500 lb)

## Gradeability/Speed/Rimpull (Tier 4 Final)

To determine gradeability performance: Read from gross weight down to the percent of total resistance. Total resistance equals actual percent grade plus 1% for each 10 kg/t (20 lb/ton) of rolling resistance. From this weight-resistance point, read horizontally to the curve with the highest obtainable gear, then down to maximum speed. Usable rimpull will depend upon traction available and weight on drive wheels.

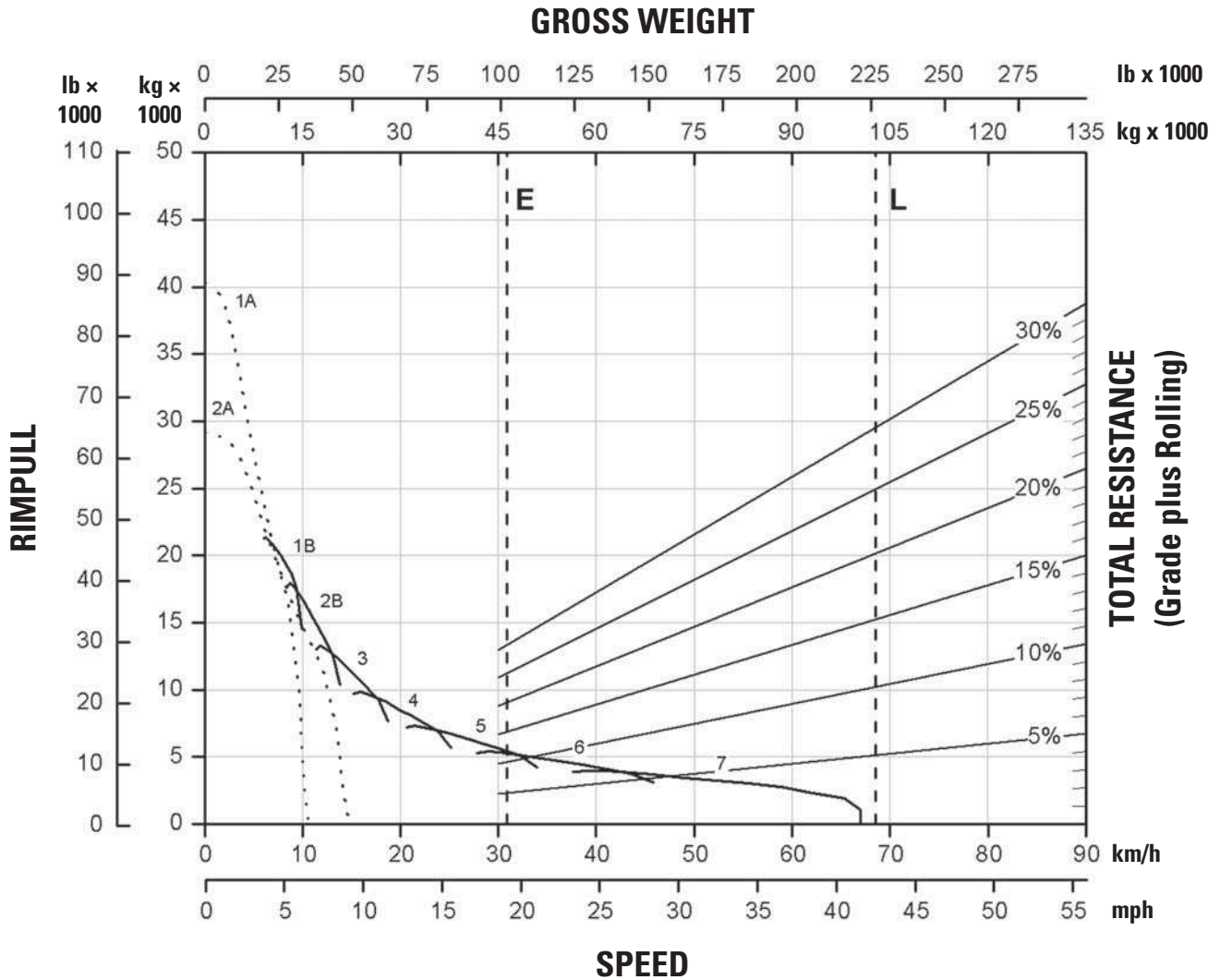

# 773G Off-Highway Truck Specifications

## Retarding Performance (Tier 2 Equivalent)

To determine retarding performance: Add lengths of all downhill segments and, using this total, refer to proper retarding chart. Read from gross weight down to the percent effective grade. Effective grade equals actual % grade minus 1% for each 10 kg/t (20 lb/ton) of rolling resistance. From this weight-effective grade point, read horizontally to the curve with the highest obtainable gear, then down to maximum descent speed brakes can properly handle without exceeding cooling capacity. The following charts are based on these conditions: 32° C (90° F) ambient temperature, at sea level, with 24.00R35 (E4) tires.

**NOTE:** Select the proper gear to maintain engine rpm at the highest possible level, without overspeeding the engine. If cooling oil overheats, reduce ground speed to allow transmission to shift to the next lower speed range.

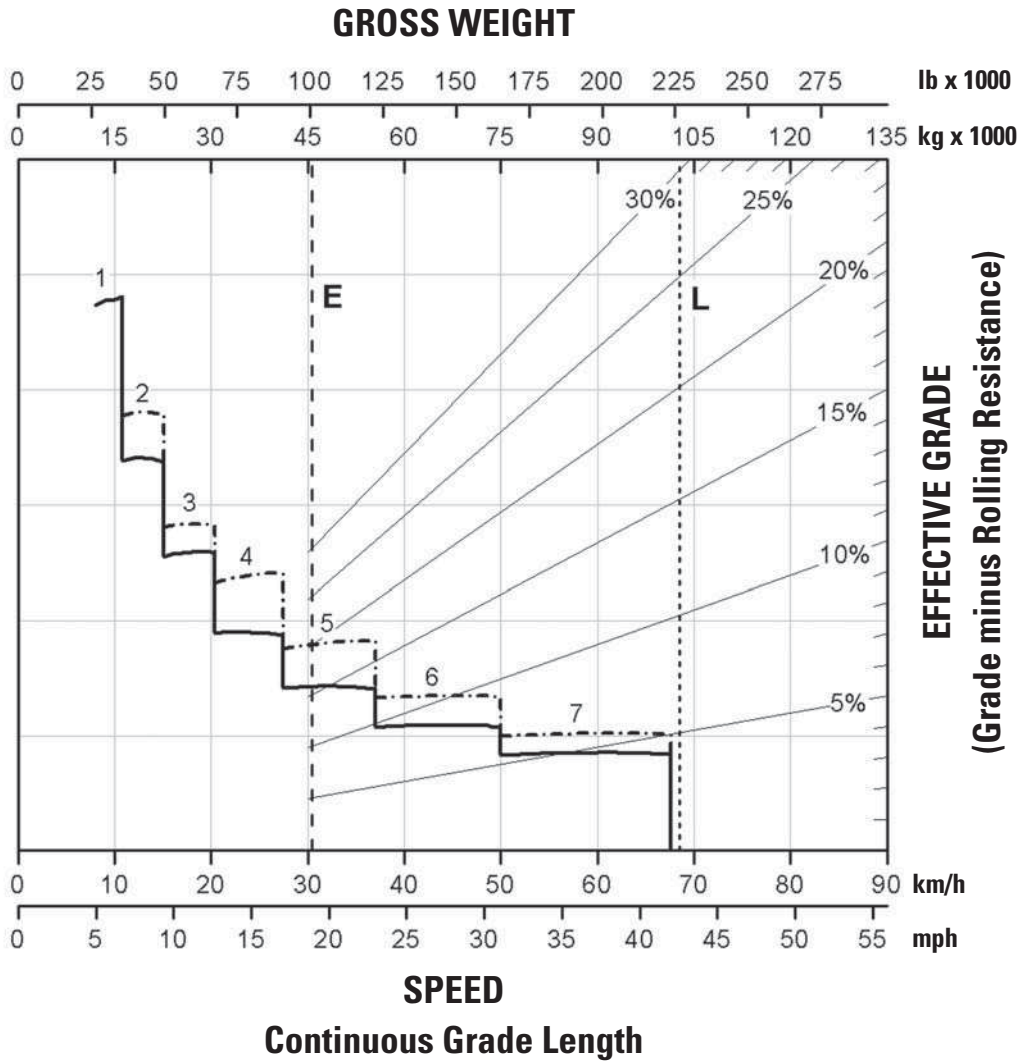

## Retarding Performance (Tier 2 Equivalent)

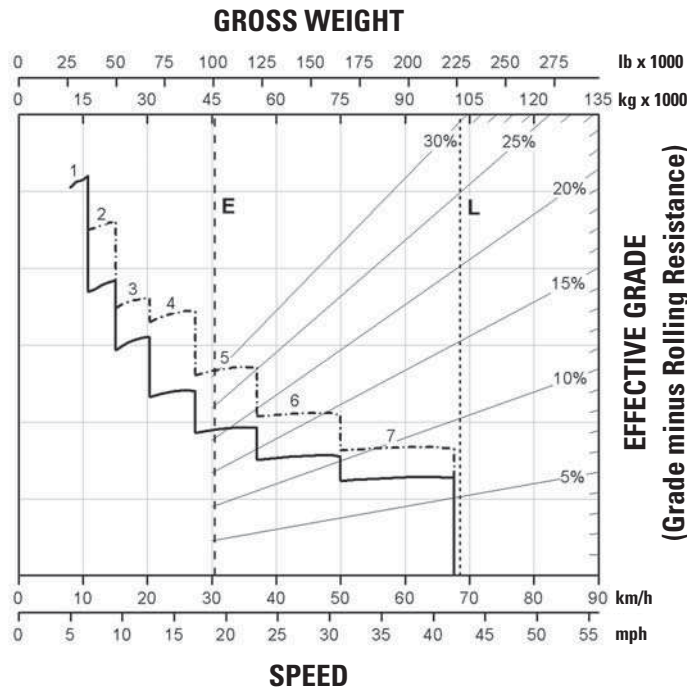
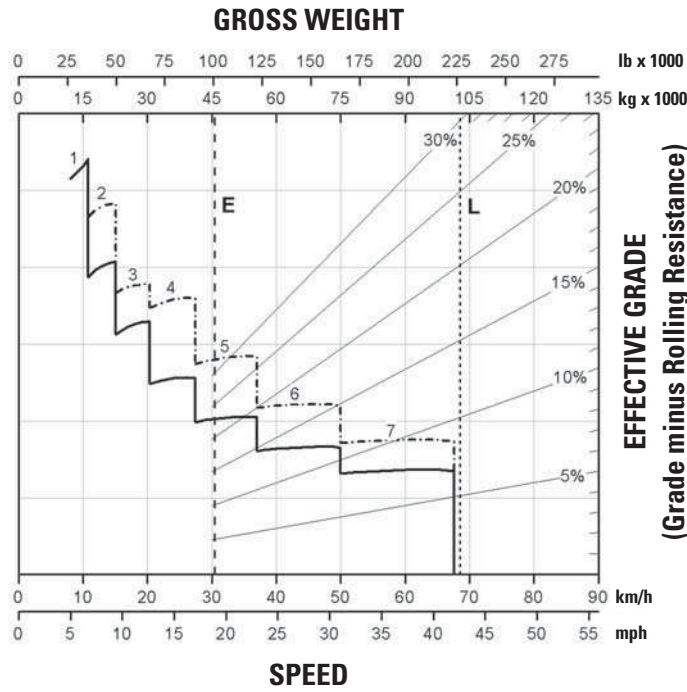

- with ARC only
- - - - - ARC and Engine Brake
- E – Typical Field Empty Weight
- L – Target Gross Machine Operating Weight 102 739 kg (226,500 lb)

# 773G Off-Highway Truck Specifications

## Retarding Performance (Tier 2 Equivalent)

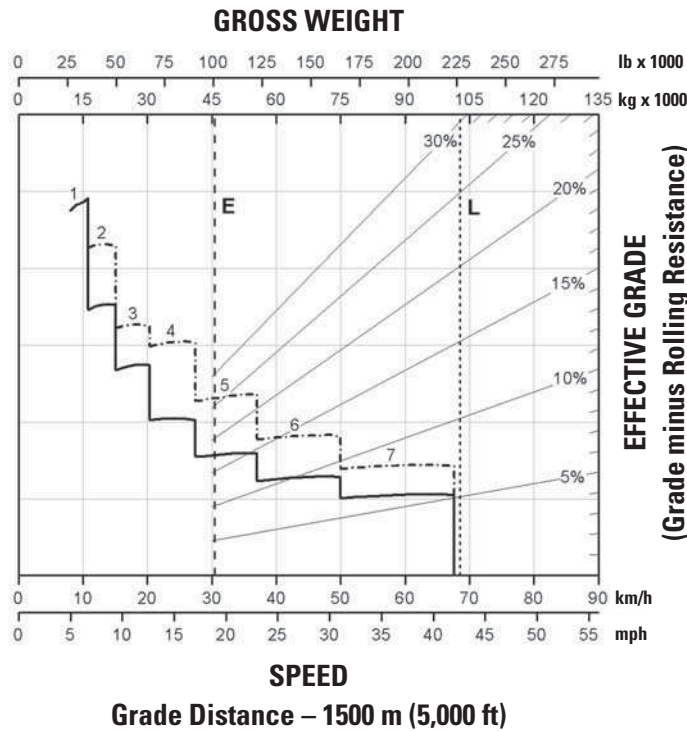
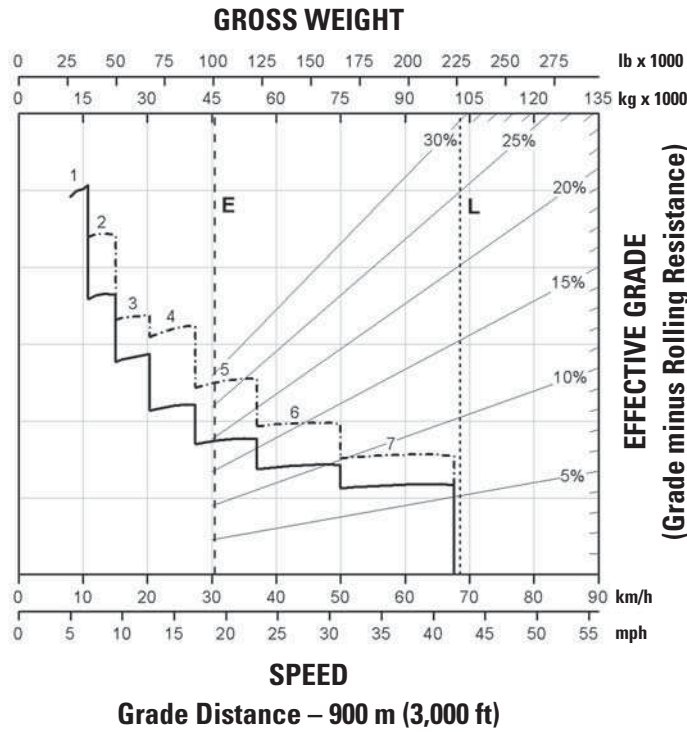

- with ARC only
- - - - - ARC and Engine Brake
- E – Typical Field Empty Weight
- L – Target Gross Machine Operating Weight 102 739 kg (226,500 lb)

## Gradeability/Speed/Rimpull (Tier 2 Equivalent)

To determine gradeability performance: Read from gross weight down to the percent of total resistance. Total resistance equals actual percent grade plus 1% for each 10 kg/t (20 lb/ton) of rolling resistance. From this weight-resistance point, read horizontally to the curve with the highest obtainable gear, then down to maximum speed. Usable rimpull will depend upon traction available and weight on drive wheels.

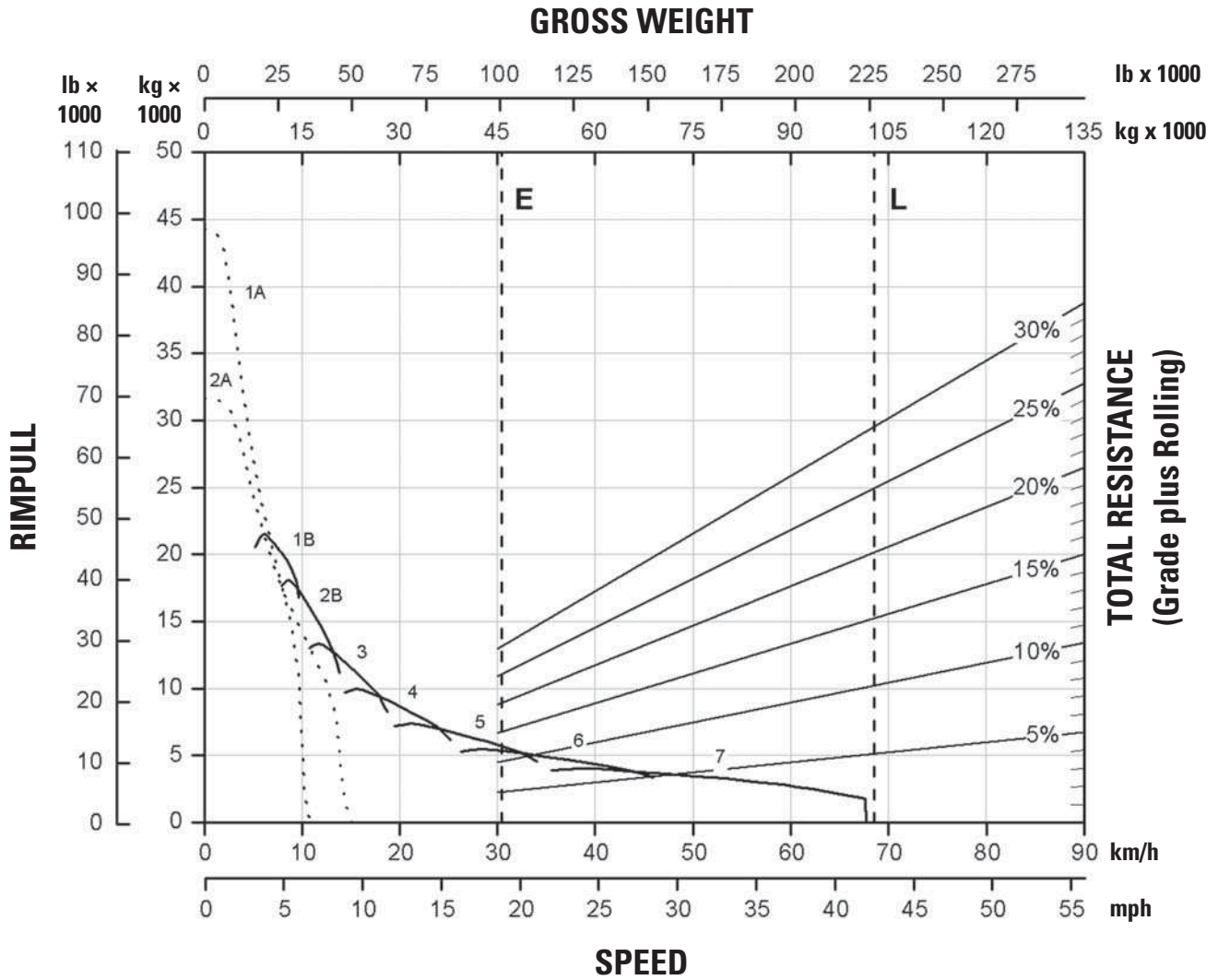

- with ARC only
- · · · · ARC and Engine Brake
- E – Typical Field Empty Weight
- L – Target Gross Machine Operating Weight 102 739 kg (226,500 lb)

## Standard Equipment

Standard equipment may vary. Consult your Cat dealer for details.

### POWER TRAIN

- Cat C27 ACERT Tier 4 Final diesel engine:
  - Air cleaner with precleaner (2)
  - Air-To-Air Aftercooler (ATAAC)
  - Electric start
  - Engine idle shutdown
  - Ether starting aid
  - Exhaust muffler
- *For Tier 4 regions only (U.S./Canada):*
  - Aftertreatment system
    - NO<sub>x</sub> Reduction System (NRS)
    - Diesel Oxidation Catalyst (DOC)
  - Demand fan
  - MEUI-C fuel system
- *For non-regulated regions only:*
  - Direct drive fan
  - MEUI-A fuel system
- Braking system:
  - Automatic Retarder Control (ARC)
  - Manual retarder (utilizes rear oil cooled, multiple disc brakes)
  - Brake release motor (towing)
  - Dry disc brakes (front)
  - Front brake disconnect switch (front)
  - Oil-cooled multiple disc brakes (rear)
  - Brake wear indicator (rear)
  - Parking brake
  - Secondary brake
  - Service brake
- Transmission:
  - 7 speed automatic powershift with
    - Electronic Clutch Pressure Control (ECPC)
    - Advanced Productivity Electronic Control Strategy (APECS)
  - Automatic neutral idle
  - Autostall
  - Second gear start

### SUSPENSION SYSTEMS

- Suspension, front and rear (EU compliant)

### ELECTRICAL

- Alarm backup
- Alternator, 120 Amp
- Autolube power supply ready
- Batteries, maintenance-free, 12V (2), 1,400 CCA combined
- Electrical system, 25 Amp, 24V to 12V converter
- Lighting system:
  - Backup light (halogen)
  - Directional signals/hazard warning (front and rear LED)
  - Engine compartment light
  - Headlights, (halogen) with dimmer
  - Operator access courtesy lights
  - Side profile lights
  - Stop/tail lights (LED)
- Service center containing:
  - Battery jump start
  - Breakers with spare fuses
  - Lock out switch
  - Ports, ET and VIMS
  - Service lockout switch (power without engine start)

### TECHNOLOGY PRODUCTS

- Economy Modes, standard and adaptive
- Product Link, cellular or satellite
- Traction Control System (TCS)
- Truck Production Management System (TPMS)
- Vital Information Management System (VIMS)

### OPERATOR ENVIRONMENT

- Advisor display:
  - Fluid level monitoring
  - Fuel level monitoring
  - Display languages (market based)
- Air conditioning/heat
- Automatic temperature control
- Ashtray and cigarette lighter
- Coat hook
- Cup holders (4)
- Diagnostic connection port, 24V
- Entertainment radio ready:
  - 5 amp converter
  - Speakers
  - Antenna
  - Wiring harness
- Foot rest
- Gauges/indicators:
  - Brake oil temperature gauge
  - Coolant temperature gauge
  - Engine overspeed indicator
  - Fuel level
  - Hour meter
  - Speedometer with odometer
  - Tachometer
  - Transmission gear indicator
- Hoist lever
- Horn
- Light – courtesy
- Light – dome
- Mirrors, non-heated
- Power port, 24V and 12V (2)
- Rollover Protection (ROPS)/Falling Object Protection (FOPS)
- Seat, Cat Comfort Series III:
  - Full air suspension
  - Retractable 3-point seat belt with shoulder harness
- Seat, training with lap belt
- Steering wheel, padded, tilt and telescopic
- Storage compartment
- Sun visor
- Throttle lock
- Window, hinged, right side (emergency exit)
- Window, powered, left side
- Windshield wiper intermittent and washer



## Standard Equipment (cont'd)

Standard equipment may vary. Consult your Cat dealer for details.

### GUARDS

- Driveline
- Engine crankcase
- Fan

### FLUIDS

- Antifreeze
- Extended life coolant to  $-34^{\circ}\text{C}$  ( $-30^{\circ}\text{F}$ )
- Grouped ground-level filters

### OTHER STANDARD EQUIPMENT

- Body down indicator
- Body safety pin (secures body in up position)
- Center mounted rims
- Fuel tank, 795 L (210 gal)
- Ground level battery disconnect
- Ground level engine shutdown
- Ground level grease fittings
- Operator Maintenance Manual (OMM)

- Rims  $17 \times 35$
- Rock ejectors
- Secondary steering (electric)
- Tie down eyes
- Tow hooks (front)/tow pin (rear)
- Vandalism protection locks

# 773G Optional Equipment

## Optional Equipment

Optional equipment may vary. Consult your Cat dealer for details.

- Body heat
- Body liner
- Body side boards
- Cab precleaner
- Cat Engine Brake
- Clustered grease fittings
- Cold weather packages
- Extended Life Brakes
- Fluid fill service center
- HID lights
- Mirrors, convex
- Mirrors, heated
- Rockford fan attachment for LRC machines
- Spare rim
- Visibility package (meets ISO 5006 requirements)
- Wheel chocks
- Work Area Vision System (WAVS)





# 773G Off-Highway Truck

For more complete information on Cat products, dealer services, and industry solutions, visit us on the web at [www.cat.com](http://www.cat.com)

© 2012 Caterpillar Inc.  
All rights reserved

Materials and specifications are subject to change without notice. Featured machines in photos may include additional equipment. See your Cat dealer for available options.

CAT, CATERPILLAR, SAFETY.CAT.COM, their respective logos, "Caterpillar Yellow" and the "Power Edge" trade dress, as well as corporate and product identity used herein, are trademarks of Caterpillar and may not be used without permission.

AEHQ6881 (09-2012)  
Replaces AEHQ6342-02

