

816K

Landfill Compactor



Engine

Engine Model	Cat® C7.1 ACERT™: configured for two emissions options	
Emissions	Meets U.S. EPA Tier 4 Final/EU Stage IV emission standards or meets U.S. EPA Tier 3/EU Stage IIIA equivalent emission standards	
Gross Power (SAE J1995)	Tier 4 Final/ Stage IV 212 kW/284 hp	Tier 3/ Stage IIIA equivalent 213 kW/286 hp
Maximum Net Torque @ 1,400 rpm	1219 N·m/899 lbf·ft	1016 N·m/749 lbf·ft

Operating Specifications

	Tier 4 Final/ Stage IV	Tier 3/ Stage IIIA equivalent
Operating Weight	25 809 kg/56,899 lb	25 541 kg/56,308 lb

Lower your operating cost with industry leading efficiency.

Contents

Efficiency and Productivity.....	4
Structures.....	6
Engine and Power Train.....	8
Wheels and Tires.....	9
Operator Station.....	10
Integrated Technologies.....	12
Waste Protection.....	13
Safety.....	14
Sustainability.....	16
Serviceability.....	17
Customer Support.....	17
Operating Costs.....	18
Specifications.....	19
Standard Equipment.....	22
Standard Attachments and Optional Equipment.....	23





Cat Landfill Compactors are designed with durability built in, ensuring maximum availability through multiple life cycles. With optimized performance and simplified serviceability, our machines allow you to operate more efficiently and safely.

Introduced in 1972, the 816 has been the industry leader for over 40 years. Focused on helping our customers succeed, we have continued to build upon each new series.

The 816K continues our legacy of reliability, performance, safety, operator comfort, serviceability, and efficiency.

Efficiency and Productivity

Delivering the efficiency and productivity you demand through integrated machine systems.



Advanced Productivity Electronic Control System (APECS)

The new APECS is designed to improve transmission shifting performance, providing a higher level of comfort for the operator and increasing productivity.

Decelerator Pedal

The left pedal acts as a brake, transmission neutralizer and an engine decelerator to override the engine speed selected by the throttle lock. This enables the operator to slow down when the throttle lock is engaged and to return to throttle lock without pressing a resume or set button again. This aids in maneuvering around trucks, tractors or any other obstacle.

Steering System

Confident machine operation starts with precise machine control enabled by the 816K's load sensing hydraulic steering system.

- Increase efficiency with our variable displacement piston pumps
- Achieve precise positioning for easy loading in tight areas with 42 degrees each way of steering articulation
- Enhance operator comfort with integrated steering and transmission control functions

Electro Hydraulic Controls

Operators increase productivity with our responsive implements feature.

- Operate comfortably through electronically controlled hydraulic cylinder stops
- Handle easy-to-use soft detent controls



1) Decelerator 2) Brake 3) Accelerator

Structures

Purpose-built from the ground up for the toughest conditions.



Robust Structures

Your bottom line is improved by highly durable structures that achieve multiple life cycles and withstand the toughest loading conditions.

- Full box-section rear frame resists torsional shock and twisting forces
- Heavy-duty steering cylinder mounts efficiently transmit steering loads into the frame
- Axle mounting has been optimized for increased structural integrity



The 816K is specifically designed and made with purpose built structures to remain safe and durable for the long run. Advanced design, materials and robotic welding contribute to increased durability and overall machine strength.

Engine and Power Train

Operate more efficiently with improved power and control.



Cat Planetary Powershift Transmission

Building your success begins with a best-in-class transmission.

- Consistent, smooth shifting and efficiency through integrated electronic controls that utilize Advanced Productivity Electronic Control System (APECS).
- Long life and reliability through heat treat gear and metallurgy.
- Two forward and two reverse speeds.

Engine and Emissions

The Cat C7.1 ACERT engine is designed for maximum fuel efficiency and increased power density. Two engine options are available to meet Tier 4 Final/Stage IV or Tier 3/Stage IIIA equivalent emission standards. This engine features innovative Cat electronics, fuel injection process, air-management systems, aftertreatment solution with Cat Selective Catalytic Reduction, and a fuel efficient regeneration system. The Cat Regeneration System automatically removes soot from the Diesel Particulate Filter without interrupting your machine's work cycle.

Efficient Systems and Components

Innovative systems intelligently lower the average working engine speeds and reduce the overall system heat loads which result in significantly improved performance and fuel efficiency.

Advanced Systems with Innovative Integration

The deep system integration of the new engine and emissions system, power train, hydraulic system and cooling system result in lower fuel consumption on average compared to previous models.

Next Generation Fuel Systems

Cat injection timing precisely controls the fuel injection process through a series of carefully timed microbursts, providing more control of combustion for the cleanest, most efficient fuel burn. On the 816K the high pressure common rail fuel systems boost performance and reduce soot for the C7.1 ACERT engine.

Cat NO_x Reduction System

The Cat NO_x Reduction System (NRS) captures and cools a small quantity of exhaust gas, then routes it back into the combustion chamber where it drives down combustion temperatures and reduces NO_x emissions.

Aftertreatment Technologies

To meet the additional 80% reduction in NO_x emissions required by Tier 4 Final/Stage IV emission standards, one new system, the Selective Catalytic Reduction (SCR), has been added to the already proven Cat Tier 4 Interim/Stage IIIB aftertreatment solution.

Wheels and Tips

More options to fit your operation.



New Long Life Paddle and Plus Design Compactor Tips

Providing up to 40% longer life than previous offering.

Designed specifically to compliment Cat machines.

Improving machine performance!

- Longer wear life
- Maintaining traction



Three new wheel and tip configurations are available to meet your particular application:

- 1) **Paddle Tip** – High performance and less fuel burn with more traction and less weight.
- 2) **Plus Tip** – Traditional design for increased side slope stability.
- 3) **Combination Tip** – Both paddle and plus tips provide the best compromise of performance and fuel economy with side slope stability.

Pictures do not represent quantity of teeth or rows.

Your operators can work more efficiently and stay comfortable with our customer-inspired cab features.



Environment

Your operator's productivity is enhanced with our clean, comfortable cab environment.

- Experience reduced vibrations from isolation cab mounts and seat air suspension
- Maintain desired cab temperature with automatic temperature controls
- Pressurized cab with filtered air
- Reduced sound levels
- Convenient floor storage tray/lunch box
- Footrest for additional comfort



Cat Comfort Series III Seat

Enhance comfort and help reduce operator fatigue with Cat Comfort Series III seat.

- Mid back design and extra thick, contoured cushions
- Air suspension system
- Easy-to-reach seat levers and controls for six way adjustments
- Floor-mounted implement pod and STIC™ steer provides greater stability
- 76 mm (3 in) wide retractable seat belt



Control Panel

Ergonomic placement of switches and information display keep your operators comfortable all day every day.

- Large backlit membrane switches feature LED activation indicators
- Switches feature ISO symbols for quick function identification
- Two position rocker switch activates the electro hydraulic park brake

Operator Station

Best-in-class operator comfort and ergonomics.



Steering and Transmission Integrated Control System (STIC)

Enter and exit the cab easily and safely with a new fold up STIC armrest.

Experience maximum responsiveness and control with STIC that combines directional selection, gear selection and steering into a single lever.

- Simple side-to-side motion turns machine right or left, minimizing operator movements
- Easy to operate finger controlled gear selection
- Smoother, faster cycles help reduce operator fatigue through the use of low effort integrated controls



Integrated Technologies

Monitor, manage, and enhance job site operations.



LINK Technologies

LINK technologies wirelessly connect you to your equipment, giving you valuable insight into how your machine or fleet is performing so you can make timely, fact-based decisions that can boost job site efficiency and productivity.

Product Link™/VisionLink®

Product Link is deeply integrated into your machine, giving you access to timely information like machine location, hours, fuel usage, idle time and event codes via the online VisionLink user interface can help you effectively manage your fleet and lower operating costs.



Cat Connect makes smart use of technology and services to improve your job site efficiency. Using the data from technology-equipped machines, you'll get more information and insight into your equipment and operations than ever before.

Cat Connect technologies offers improvements in these key areas:



EQUIPMENT MANAGEMENT

Equipment Management – increase uptime and reduce operating costs.



PRODUCTIVITY

Productivity – monitor production and manage job site efficiency.



SAFETY

Safety – enhance job site awareness to keep your people and equipment safe.



Rear Vision Camera

A rear vision camera greatly enhances visibility behind the machine to help the operator work more productively. Work with greater confidence and at peak potential while keeping people and assets safe.

COMPACT Technologies

COMPACT technologies combine advanced compaction measurement, in-cab guidance, and reporting capabilities to help you consistently meet compaction targets fast, uniformly, in fewer passes – saving on fuel and rework.

Cat Compaction Control

The factory-installed Cat Compaction Control system uses the Cat Compaction Algorithm to measure effective compaction value and deliver real-time 3D pass mapping guidance to the cab, indicating where to work and when layers are compacted to optimum density. Pass mapping helps eliminate voids, optimize cell space, and document results. VisionLink 3D Project Monitoring provides landfill managers with detailed compaction analysis to more effectively monitor and manage their operation.

Waste Protection

Maximize uptime, long life – it's what you expect from your bottom line.

Guarding

Working in the toughest application, the purpose built 816K Landfill Compactor has specialized waste guarding to protect key components and systems from damage, debris, chemicals, premature wear, or wrapping of the material around components. This additional guarding includes:

- **Engine and Power Train Guards** – Guards help prevent trash build-up and shield components.
- **Front Frame Guards** – Front frame guards prevent trash build-up inside the frame. This guard further protects components and hydraulic lines.
- **Axle Wrapping and Seal Guarding** – The guarding prevents material from wrapping and binding around the axles, as well as assist in ease of cleaning.
- **Major System Guarding and Sight Gauges** – Transmission oil tube is guarded to resist damage from debris. The sight gauge for the transmission is visible from ground level. The fuel tank is positioned away from the debris in the front frame and is easily accessed.
- **High Radiator Air Inlet with Screen** – Helps prevent trash from entering the radiator area, maintaining proper airflow and allows for debris to fall off.
- **Striker Bars and Optional Cleaner Fingers** – Striker bars are located in front of and behind the rear wheels and behind the front wheels. Striker bars help to keep wheels free of debris to assist the wheel tips in maintaining good compaction. In cohesive material or severe packing conditions, optional cleaner fingers are available to further assist in keeping the wheel tips clean.
- **Extended Roof** – An oversized roof extends past the cab doors and windows to minimize debris build up.
- **Suction Fan** – Allows ambient air to cool, providing better cooling capacity. It also pressurizes the engine compartment, preventing trash build up.

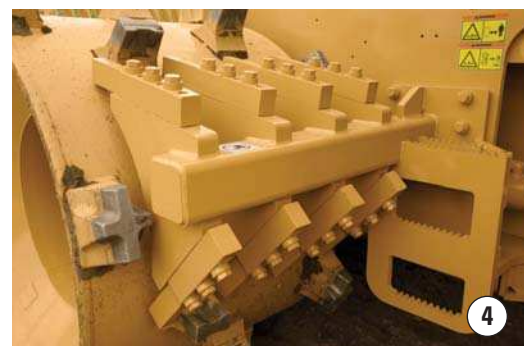
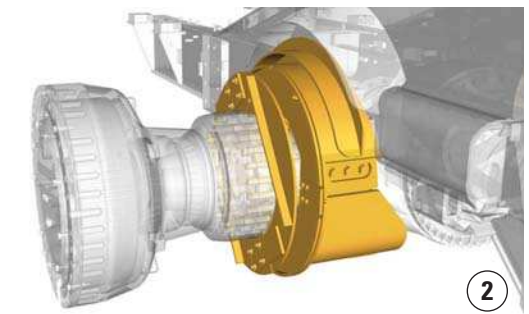

1) Engine and Power Train Guards 2) Axle Guards
3) Air Inlet Screen 4) Striker Bars/Cleaner Fingers



Safety

Making your safety our priority.

We are constantly improving our products in an effort to provide a safe work environment for the operator and those who work on your job site.

Machine Access

- Railings, ladders and non-slip surfaces enhance technician and operator safety
- Maintain three points of contact at all times through ground level or platform accessible service areas



Visibility

- Rearview camera with in-cab monitor increases operator awareness around the machine
- Standard cab mounted LED warning strobes

Operator Environment

- Increased stability for the operator with isolated cab mounts and floor-mounted implement and steering controls
- Low interior sound levels
- Pressurized cab with filtered air
- Standard 76 mm (3 in) seat belts on the operator seat

Sustainability

Stewards of the environment.



Reducing the Impact to the Environment

The 816K is designed and built with sustainability in mind.

- Engine Idle Shutdown can help you save fuel by avoiding unnecessary idling.
- Reduce waste to the environment with our maintenance free batteries.
- To assist with maximizing machine life, the Cat 816K is built for multiple lives and is one of our most rebuilt products. To get the most value from your investment, Caterpillar offers sustainable options such as our Cat Reman and Certified Rebuild programs. In these programs, remanufactured components deliver cost savings of 40 to 70 percent, which lowers your operating cost while also reducing waste and minimizing the need for raw materials.
- Caterpillar offers retrofit packages to bring new features to older machines, maximizing your resource. And, when you go through the Cat Certified Rebuild program, these retrofit kits are part of the rebuild process.

Serviceability

Enabling high uptime by reducing your service time.



We can help you succeed by ensuring your 816K has design features to reduce your downtime.

- Safe and convenient service with ground level or platform access and grouped service points.
- Swing-out doors on both sides of the engine compartment provide easy access to important daily service checks.
- Ecology drains for ease of service and prevention of spills.
- Reduce downtime with VIMS system notifications so your operators and technicians can resolve any problems before failure.
- Quick visual inspection and minimize fluid contamination with sight gauges.
- Side access doors provided for cleanout of the cooling package.
- A new ground level service area includes a Master Disconnect Switch with integrated lock-out/tag-out, DEF purge lamp (Tier 4 Final/Stage IV machines only), circuit breakers, emergency fuel shutoff switch and the jump start receptacle.
- Centralized grease points for convenient maintenance.

Customer Support

Your Cat dealers know how to keep your machines productive.

Legendary Cat Dealer Support

A valued partner, your Cat dealer is available whenever you need them.

- Preventive maintenance programs and guaranteed maintenance contracts
- Best-in-class parts availability
- Improve your efficiency with operator training
- Genuine Cat Remanufactured parts





Operating Costs

Save time and money by working smart.

Data from customer machines show Cat Landfill Compactors are among the most fuel efficient machines in the industry. Several features contribute to this excellent fuel efficiency:

- **ACERT Engine** – Advanced engine controls maximizes power and efficiency.
- **Engine Idle Shutdown** – Automatic engine and electrical system shutdown conserves fuel.
- **Advanced Productivity Electronic Control System (APECS)** – All new APECS transmission controls provides greater momentum on grades and fuel savings by carrying that momentum through the shift points.
- **Fuel Tank Capacity** minimum of 12 hours operation depending on the application.

816K Landfill Compactor Specifications

Engine

Engine Model	Cat C7.1 ACERT	
	Tier 4 Final/Stage IV	
Rated Power (SAE J1349)	185 kW	248 hp
Rated Power (Net ISO 9249)	185 kW	248 hp
Gross Power (SAE J1995)	212 kW	284 hp
Gross Power (ISO 14396)	204 kW	274 hp
Maximum Net Torque @ 1,400 rpm	1219 N·m	899 lbf-ft
	Tier 3/Stage IIIA equivalent	
Rated Power (SAE J1349)	186 kW	249 hp
Rated Power (Net ISO 9249)	186 kW	249 hp
Gross Power (SAE J1995)	213 kW	286 hp
Gross Power (ISO 14396)	205 kW	275 hp
Maximum Net Torque @ 1,400 rpm	1016 N·m	749 lbf-ft
Torque Rise	52%	
Maximum Altitude without Derating	3000 m	9,842.52 ft
Bore	105 mm	4.1 in
Stroke	135 mm	5.3 in
Displacement	7.01 L	427.8 in ³
High Idle Speed	2,270 rpm	
Low Idle Speed	800 rpm	

Operating Specifications

Maximum Operating Weight (Tier 4 Final/Stage IV)	25 809 kg	56,899 lb
Maximum Operating Weight (Tier 3/Stage IIIA equivalent)	25 541 kg	56,308 lb

Transmission

Transmission Type	Planetary – Powershift – ECPC	
Travel Speeds		
Forward – First	6.1 km/h	3.8 mph
Forward – Second	10.9 km/h	6.8 mph
Reverse – First	7.0 km/h	4.3 mph
Reverse – Second	12.5 km/h	7.8 mph

Hydraulic System

Pump Flow at 2,111 rpm	89 L/min	23.5 gal/min
Main Relief Pressure	22 000 kPa	3,190 psi
Maximum Supply Pressure	20 200 kPa	2,930 psi
Cylinder, Double-acting:	120 mm ×	4.7 in ×
Lift, Bore and Stroke	915 mm	36.0 in

Service Refill Capacities

Cooling System – Tier 4 Final/Stage IV	81 L	21.4 gal
Cooling System – Tier 3/Stage IIIA equivalent	73 L	19.3 gal
Engine Crankcase	20 L	5.28 gal
Transmission	56 L	14.8 gal
Fuel Tank	500 L	132.1 gal
Diesel Exhaust Fluid Tank (Tier 4 Final/Stage IV only)	16 L	4.2 gal
Differentials and Final Drives – Front	43 L	11.4 gal
Differentials and Final Drives – Rear	43 L	11.4 gal
Hydraulic Tank Only	75 L	19.8 gal

- All non-road Tier 4 Final and Stage IV diesel engines are required to use:
 - Ultra Low Sulfur Diesel (ULSD) fuels containing 15 ppm for the EPA, 10 ppm for the EU (mg/kg) sulfur or less. Biodiesel blends up to B20 are acceptable when blended with 15 ppm (mg/kg) sulfur or less ULSD and when the biodiesel feedstock meets ASTM D7467 specifications.
 - Cat DEO-ULS™ or oils that meet the Cat ECF-3, API CJ-4, and ACEA E9 specifications are required.
 - Diesel Exhaust Fluid (DEF) that meets all requirements defined in ISO 22241-1.

Axles

Front	Planetary – Fixed
Rear	Planetary – Oscillating
Oscillation Angle	±6°

Brakes

Parking Brake	Drum and Shoe, Spring Applied, Hydraulic Released
---------------	---

816K Landfill Compactor Specifications

Cab

	Standard	Suppression
Operator Sound Level (ISO 6396)	71 dB(A)	70 dB(A)
Machine Sound Level (ISO 6395) (Tier 4 Final/Stage IV)	111 dB(A)	109 dB(A)
Machine Sound Level (ISO 6395) Tier 3/Stage IIIA equivalent	112 dB(A)	110 dB(A)

Hydraulic System – Steering

Steering System – Circuit	Closed Center Load Sensing	
Bore	101.6 mm	4.0 in
Stroke	597 mm	23.5 in
Steering System – Pump	Piston – Variable Displacement	
Maximum System Flow	147 L/min @ 2,111 rpm	38.8 gal/min @ 2,111 rpm
Steering Pressure Limited	27 600 kPa	4,003 psi
Vehicle Articulation Angle	84 degrees	

Blades

Width – Moldboard Length	3580 mm	11.75 ft
Height Including Cutting Edge and Screen	1961 mm	6.4 ft
Maximum Depth of Cut	362 mm	1.2 ft
Maximum Lift Above Ground	1140 mm	3.7 ft
Width Over End Bits	3656 mm	12.0 ft

Wheels

Paddle Tips

Weight (Group)	5954 kg	13,126 lb
Outside Diameter	1717 mm	67.6 in
Drum Diameter	1400 mm	55.1 in
Drum Width	1016 mm	40.0 in
Tips per Row	5	
Tips per Wheel	20	
Replaceable	Welded	
Width over Drums	3338 mm	131.4 in
Tip Height	159 mm	6.25 in

Plus Tips

Weight (Group)	6342 kg	13,982 lb
Outside Diameter	1717 mm	67.6 in
Drum Diameter	1400 mm	55.1 in
Drum Width	1016 mm	40.0 in
Tips per Row	5	
Tips per Wheel	20	
Replaceable	Welded	
Width over Drums	3338 mm	131.4 in
Tip Height	159 mm	6.25 in

Combo Wheels

Weight (Group)	6148 kg	13,554 lb
Outside Diameter	1717 mm	67.6 in
Drum Diameter	1400 mm	55.1 in
Drum Width	1016 mm	40.0 in
Tips per Row	5	
Tips per Wheel	20	
Replaceable	Welded	
Width over Drums	3338 mm	131.4 in
Tip Height	159 mm	6.25 in

816K Landfill Compactor Specifications

Dimensions

All dimensions are approximate.

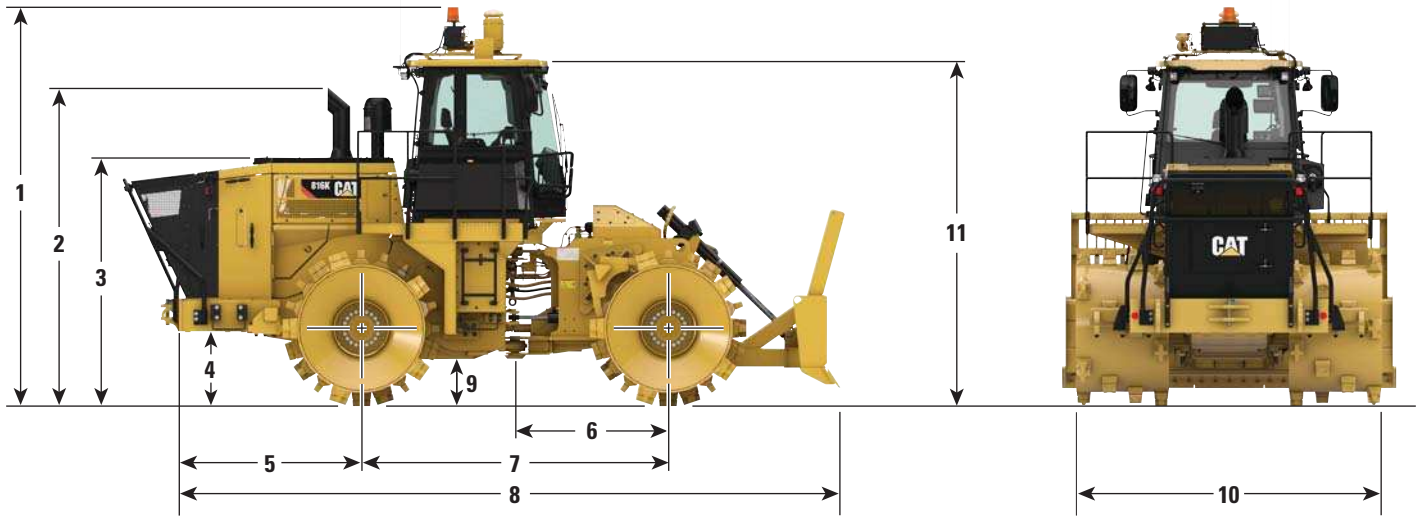

1 Height to Top of Beacon	4368 mm	14.3 ft
2 Height to Top of Exhaust Pipe	3497 mm	11.5 ft
3 Height to Top of Hood	2720 mm	8.9 ft
4 Ground Clearance to Bumper	818 mm	2.7 ft
5 Center Line of Rear Axle to Bumper	1990 mm	6.5 ft
6 Hitch to Center Line of Front Axle	1675 mm	5.5 ft
7 Wheelbase	3350 mm	11.0 ft
8 Overall Length (maximum)	8058 mm	26.4 ft
9 Ground Clearance	516 mm	1.7 ft
10 Width over Wheels	3338 mm	131.4 ft
11 Height to Cab Roof	3878 mm	12.7 ft
Inside Turning Radius (Wheels)	2700 mm	8.9 ft
Inside Turning Radius (Blade)	2910 mm	9.5 ft
Outside Turning Radius (Blade)	6473 mm	21.2 ft

Standard Equipment

Standard equipment may vary. Consult your Cat dealer for details.

POWER TRAIN

- Advanced Productivity Electronic Control Shifting (APECS)
- Air to air aftercooler
- Brakes, full hydraulic, enclosed, wet multiple disc service brakes
- Cat clean emission module (Tier 4 Final/Stage IV only)
- Electro-hydraulic parking brake
- Electronic Clutch Pressure Control (ECPC)
- Engine, Cat C7.1 with ACERT Technology: configured for two emissions options
 - Tier 4 Final/Stage IV
 - Tier 3/Stage IIIA equivalent
- Engine driven cooling fan (suction)
- Fuel priming pump (electric)
- Fuel to air cooler
- Ground level engine shutoff
- Muffler (under hood) (Tier 3/Stage IIIA equivalent only)
- Radiator, unit core
- Starting aid (ether)
- Throttle lock
- Transmission, planetary with 2F/2R speed range control
- Torque converter

ELECTRICAL

- Alarm, back-up
- Alternator (150 amp)
- Batteries, maintenance free
- Electrical system (24 volt)
- Ground level lockable master disconnect switch
- Light, warning unswitched (LED strobe)
- Lighting system (front and rear)
- Starter, electric
- Starting receptacle for emergency start

OPERATOR ENVIRONMENT

- 12-volt power port for mobile phone or laptop connection
- AccuGrade™ mapping (ready)
- Air conditioner with roof mounted condenser
- Cab, sound-suppressed pressurized
- Camera, rear vision
- Coat and hard hat hooks
- Finger tip shifting controls
- Flip-up armrest
- Heater and defroster
- Horn, electric
- Hydraulic controls – floor mounted
- Implement hydraulic lockout
- Instrumentation, gauges:
 - DEF fluid level (Tier 4 Final/Stage IV only)
 - Engine coolant temperature
 - Fuel level
 - Hydraulic oil temperature
 - Speedometer/tachometer
 - Torque convertor temperature
- Instrumentation, warning indicators:
 - Action alert system, three category
 - Brake oil pressure
 - Electrical system, low voltage
 - Engine failure malfunction alert and action lamp
 - Parking brake status
- Internal four-post rollover protective structure (ROPS/FOPS)
- Light, (dome) cab
- Lunch box and beverage holders
- Mirror, internal (panoramic)
- Mirrors, rearview (externally mounted)
- Radio, CB ready
- Radio ready for entertainment:
 - Antenna
 - Speakers
 - Converter (12-volt 10-15 amp)
- Seat belt with minder, retractable, 76 mm (3") wide
- STIC control system with lockout
- Sun visor, front

- Tinted glass
- Transmission gear (indicator)
- Vital Information Management System (VIMS):
 - Graphical information display
 - External data port
 - Customizable operator profiles
 - Event indicator light on rear grill
- Wet-arm wipers/washers (front and rear)
 - Intermittent wipers (front and rear)

GUARDS

- Guards, axle (front and rear)
- Guard, cab window
- Guards, crankcase and power train, hinged
- Guard, driveshaft
- Guard, radiator
- Striker bars

FLUIDS

- Antifreeze, premixed 50% concentration extended life (–34° C/–29° F)

OTHER STANDARD EQUIPMENT

- DEF tank fill gauge (Tier 4 Final/Stage IV only)
- Doors, service access (locking)
- Ecology drains for engine, radiator, transmission, hydraulic tank
- Engine, crankcase, 500 hour interval with CJ-4 oil
- Emergency egress
- Fire suppression ready
- Fuel tank, 500 L (132 gal)
- Hitch, drawbar with pin
- Hoses, Cat XT™
- Hydraulic, engine, and transmission oil coolers
- Oil change system, high speed
- Oil sampling valves
- Steering, load sensing
- Total hydraulic filtration system
- Vandalism protection caplocks
- Venturi stack

816K Standard Attachments and Optional Equipment

Standard Attachments

Standard attachments may vary. Consult your Cat dealer for details.

OPERATOR ENVIRONMENT

- Glass (window)
 - Standard bonded or rubber-mounted glass
- Horn group (standard)
- Horn group (trumpet)
- Lights – cab
 - Standard or LED
- Mirrors – cab
 - Standard or heated
- Precleaner – cab
 - Standard or powered
- Seat – cab
 - Standard or heated and ventilated

POWER TRAIN

- Axles
 - Axle arrangement (no spin front)
 - Axle arrangement (no spin rear)
 - Axle arrangement (no spin front and rear)

SPECIAL ARRANGEMENTS

- Engine precleaners
 - Turbine or dual stage

BLADES

- Dozer Arrangement – Standard (No Blade)
- Dozer Arrangement – Straight Blade
- Dozer Arrangement – Tilt (No Blade)

TECHNOLOGY PRODUCTS

- Product Link
 - GSM, satellite

WHEELS AND CLEANER BARS

- Wheels and tips
 - Wheel arrangement (6.25" plus tip)
 - Wheel arrangement (6.25" paddle tip)
 - Wheel arrangement (6.25" plus and paddle)
 - Wheels, chopper
- Bar group – cleaner (cleaner fingers and striker bar)

Optional Equipment

Optional equipment may vary. Some options may be included/excluded in arrangement packages. Consult your Cat dealer for details.

OPERATOR ENVIRONMENT

- Radio, AM/FM/AUX/USB/BLUETOOTH

FLUIDS

- Antifreeze, –50° C (–58° F)

SPECIAL ARRANGEMENTS

- Engine
 - Sound suppression

STARTING AIDS

- Heater, engine coolant, 120V
- Heater, engine coolant, 240V

MISCELLANEOUS

- Film (ANSI) (Tier 4 Final/Stage IV only)
- EU certification (Tier 4 Final/Stage IV only)
- Plate – year of manufacture (Tier 3/Stage IIIA equivalent only)

For more complete information on Cat products, dealer services, and industry solutions, visit us on the web at www.cat.com

AEHQ7747 (05-2016)

© 2016 Caterpillar
All rights reserved

Materials and specifications are subject to change without notice. Featured machines in photos may include additional equipment. See your Cat dealer for available options.

CAT, CATERPILLAR, SAFETY.CAT.COM, their respective logos, "Caterpillar Yellow" and the "Power Edge" trade dress, as well as corporate and product identity used herein, are trademarks of Caterpillar and may not be used without permission.

VisionLink is a trademark of Trimble Navigation Limited, registered in the United States and in other countries.



Courtesy of Machine.Market