

906M, 907M, 908M

Compact Wheel Loaders



	906M	907M	908M
Engine Model	Cat® C3.3B DIT*	Cat C3.3B DIT*	Cat C3.3B DIT*
Maximum Gross Power:			
ISO 14396 (DIN)	55 kW (74 hp)	55 kW (74 hp)	55 kW (74 hp)
SAE J1995	55 kW (74 hp)	55 kW (74 hp)	55 kW (74 hp)
Bucket Capacity	0.75 m ³ -1.2 m ³ (1.0 yd ³ -1.6 yd ³)	0.75 m ³ -1.2 m ³ (1.0 yd ³ -1.6 yd ³)	0.9 m ³ -1.5 m ³ (1.2 yd ³ -2.0 yd ³)
Full Turn Tipping Load	3405 kg (7,507 lb)	3500 kg (7,716 lb)	3770 kg (8,311 lb)
Operating Weight	5600 kg (12,346 lb)	5750 kg (12,677 lb)	6365 kg (14,032 lb)

*The Cat C3.3B DIT engine meets U.S. EPA Tier 4 Final/EU Stage IIIB emission standards or Tier 4 Interim/Stage IIIA equivalent emission standards.

Experience the Difference.

Optimized Parallel Lift Z-bar Linkage

Combines the digging efficiency of a traditional Z-bar with tool carrier capabilities for superior performance and flexibility.

Cab and Controls

Large, spacious cab features excellent visibility to the front and rear, extremely low sound levels and low-effort ergonomic joystick controls so you can concentrate on your work.

Electronic Power Management

An electronically controlled hydrostatic transmission provides adjustable power to the ground and superb groundspeed control for fast digging cycles and the flexibility to efficiently perform a multitude of tasks.

Powerful Predictable Hydraulics

The system is optimized for fast cycle times while delivering higher breakout forces. Working with buckets, forks and other work tools has never been more efficient.

Work Tools

Whether using an ISO (wide) or Skid Steer Loader (SSL) style coupler, combined with standard or optional high flow hydraulics, the Cat Compact Wheel Loaders can use a large range of work tools.

Serviceability

Extended service intervals and excellent service access make daily checks quick and easy, allowing you to get to work sooner.

Contents

M Series Compact Wheel Loaders	4
Parallel Lift Loader Linkage	5
Industry Leading Operator Station	6
Power Train	7
Couplers	8
Hydraulics	9
Work Tools	10
Reliability and Durability	11
Options	12
Serviceability and Customer Support	13
Specifications	14
Standard and Optional Equipment	34





The Cat 906M, 907M and 908M Compact Wheel Loaders deliver high performance with outstanding versatility. On-the-go operator tuned hydraulics and drive train adjust the machine's response to the task at hand. Low sound levels, large spacious cab and intuitive controls keep you working comfortably all day long.

M Series Compact Wheel Loaders

A comprehensive range to suit all applications and environments.

906M

This low cab machine provides access to more areas on site and applications allowing for low entry machines. It is designed with simplicity and cost effectiveness in mind while still delivering great all-round performance to work in a wide range of applications.

- 0.9 m³ (1.2 yd³) operating capacity
- Great for rental fleets
- Low height over cab
- 18" rim size



907M

With more operating capacity than the 906M and a higher mounted cab, this model can work in applications where clearance is not critical.

- 1.0 m³ (1.31 yd³) operating capacity
- Standard height over cab
- 18" rim size



908M

Boasts higher operating capacity, engine horsepower, breakout forces and hydraulic power allowing it to operate in tougher conditions.

- 1.1 m³ (1.44 yd³) operating capacity
- Standard height over cab
- 20" rim size



Parallel Lift Loader Linkage

Cat Optimized Z-bar Loader delivers enhanced visibility with maximum productivity.



Cat Optimized Z-bar Loader

The Cat Optimized Z-bar Loader combines the digging efficiency of a traditional Z-bar with tool carrying capabilities for great performance and versatility.

- Parallel lift and high tilt forces throughout the working range help you safely and confidently handle loads with precise control.
- Linkage features excellent visibility to the bucket cutting edge and fork tips.

Industry Leading Operator Station

Superior visibility, ergonomics and comfort.



Best Seat on the Job Site

Enjoy all day comfort in the spacious M Series cab:

- Low effort, responsive joystick includes integrated Forward/Neutral/Reverse switch, differential lock and continuous flow triggers along with proportional, third function auxiliary hydraulics.
- Easy access to the cab with ergonomically placed grab rails, steps and large platform.
- Low sound levels.
- Superior visibility to the work tool due to the wide windshield and Cat Optimized Z-bar Loader.
- Optional air conditioning with defrost/demist.
- Optional heated, air suspension seat with lumbar and seat back tilt adjustment.

Easy to Use Instrument Panel and Display

The front console provides easy access to vital machine information, along with lights and ECO mode switches. ECO mode saves fuel and reduces engine wear with an engine speed control. The right hand console holds secondary functions beyond the all-in-one joystick controller.

- New soft touch keypad on the right hand console contains new electronic functions and settings including Implement Modulation, Hystat Aggressiveness, Ride Control, Return To Dig, Engine Speed Control and Rimpull Control.
- LCD read out for: travel speed, engine speed, speed range selection, hydraulic oil temperature, service hour meter, engine coolant temperature, and fuel level.
- Indicators: diesel particulate filter, starting aid, engine, electrical, parking brake, directional turn signals, brakes, high beams, action required notice, continuous flow, hydraulic filter bypass, bucket float, creeper, directional F/N/R.



Power Train

Hydrostatic drive adjusts to be faster or smoother for the task.

Intelligent Power Management

The Cat power train is computer controlled which actively monitors engine, operator input and drive train load, adjusting the hystat transmission to keep the machine working at peak efficiency.



Engine

The Cat C3.3B turbo engine provides cleaner, quieter operation while delivering superior performance and durability.

The engine also features:

- The Cat C3.3B Tier 4 Final/Stage IIIB uses an active regeneration system which requires no operator interaction under normal conditions.
- Automatic, electronic, self-priming fuel pump encourages good maintenance practice. At the service interval, simply install a clean, dry filter element and then turn the ignition key to ON.
- The easily accessible diesel particulate filter has a minimum 3,000 hour cleaning service interval. The on-board monitor will advise when diesel ash cleaning service is needed.
- Focused on fuel efficiency, significantly reducing owning and operating costs.

Transmission

- The Hystat Aggressiveness feature allows the operator to increase the directional shift responsiveness for faster loading cycles, or adjust for finer control for sensitive tasks such as moving heavy pallets.
- Rimpull Control feature enables the operator to match available tractive power to underfoot conditions, helping reduce tire wear.
- Creeper Control precisely adjusts the machine ground speed when using work tools such as brooms and snow blowers.
- Electronic Engine Speed Control feature allows you to maintain constant engine RPM regardless of travel speed.
- Thus, pairing Creeper Control and Engine Speed Control, the operator can easily control the hydraulic power going to the work tool, while optimizing ground speed for best operation.
- Three speed ranges ensure maximum controllability for any task.

Axles, Brakes and Inching Function

- Fully locking front and rear differential axles are standard and can be engaged at full torque on-the-go below 6 km/h (4 mph), with a button on the joystick.
- The enhanced modulation of the inching function utilizes the first half of brake pedal engagement to hydrostatically decelerate without any wear on the braking system.
- The brake system includes independent service brakes on the front and rear axles. The parking brake is mechanically activated and released with a hand lever next to the operator's seat.

Couplers

Making the Compact Wheel Loader even more versatile.

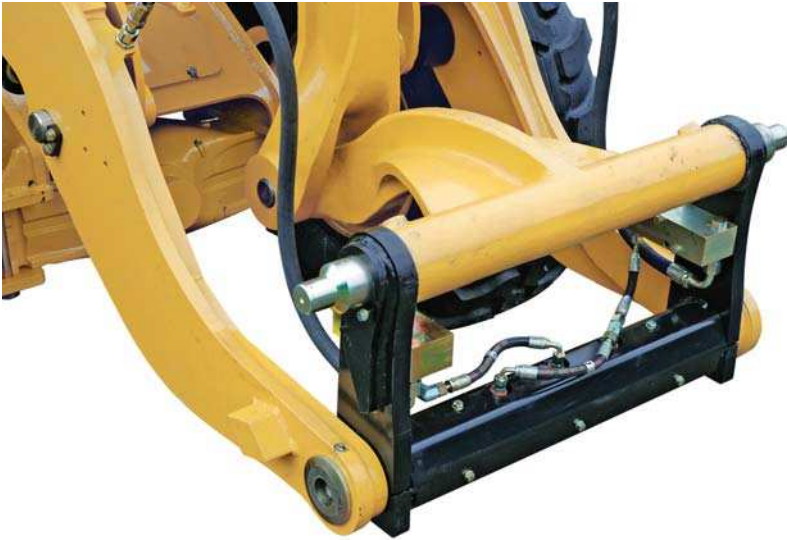

Horizontal Pin Coupler – ISO

This quick coupler will pick up a range of Cat Compact Wheel Loader work tools. The coupler along with the profiled loader arms have been designed to give maximum visibility to the work tool. A simple joystick function allows for easy engagement and disengagement of the locking pins.

Horizontal Pin Coupler – A

This coupler is an evolution of the existing ISO horizontal pin coupler and thus has the in built durability and robust design that has been in the market place for many years.

This design gives a zero offset coupler from the machine, which optimizes the load capacity and breakout forces vs. some AEM solutions that are less integrated.



Skid Steer Loader Coupler

The universal skid steer loader coupler allows the use of many Cat Skid Steer Loader work tools. Using either the standard or high flow hydraulic option, this coupler allows the M Series Compact Wheel Loaders to integrate into a skid steer loader fleet.



Hydraulics

Operator tuned hydraulics matches responsiveness to the task.

Hydraulic System

M Series machines feature a new electro-hydraulic control system, which allows the operator the ability to fine tune the machine based on the application and operator preference.

- The new electronic joystick operation is finely tuned for smooth operation, yet fast cycle times.
- The Implement Modulation feature provides three settings for faster, more responsive hydraulics for repetitive tasks like truck loading. Or, this feature can adjust for smoother hydraulics needed with heavy fork loads or more restrictive areas.
- An electronic Return To Dig feature levels the bucket as the loader comes down after dumping. This speeds cycle times by letting the operator focus on the next dig point rather than setting the bucket position.
- The third function auxiliary hydraulics can be set for Continuous Flow when using hydro-mechanical work tools.
- Ride Control is available to smooth the ride, keep the tires in contact with the ground and maximize material retention.



Work Tools

Do more jobs with one machine.

The Right Tool for the Job

An extensive range of work tools and bucket styles are available to make your Cat Compact Wheel Loader one of the most versatile machines on the job site. Cat work tools are designed to get the best out of the machine and deliver excellent value through high productivity and long life.

Work Tools for Cat Horizontal Pin Coupler

The Cat Compact Wheel Loader offers a comprehensive range of buckets to suit any environment and specific customer needs. The buckets have been designed and engineered to endure the high breakout forces of the M Series Compact Wheel Loader.

The Cat fork carriage has been designed to increase visibility to the forks, allowing the operator to work much more efficiently and safely, without compromising durability. Various fork tine lengths are available.

Work Tools for Cat Skid Steer Loader Coupler

This coupler allows the use of a wide range of Cat Skid Steer Loader work tools including many hydro-mechanical work tools such as snow blowers, cold planers, brooms and wheel saws. It is recommended to check the work tool requirements to ensure the machine is configured for optimal performance with features such as High Flow and Return To Dig.

Auxiliary Lines and Connectors

The auxiliary lines and connectors are fitted as standard, meaning the Cat Compact Wheel Loader comes ready to work.

For a complete list of available work tools please consult your local Cat dealer.





Reliability and Durability

Quality within, quality throughout.



E-Coat Protection

Cat Compact Wheel Loaders undergo an extensive 24-Stage 'E-Coat' process. Zinc based electroplated undercoat and polyurethane topcoat provides unmatched corrosion resistant properties.



Heavy Duty Axles

The M Series Compact Wheel Loaders are fitted with heavy duty axles, with outboard planetary reduction gears.

Wiring

With heavy-duty braided wiring, Cat Compact Wheel Loaders offer great electrical durability. The water resistant sealed connectors prevent dust and moisture interfering with the electrics. Multicolored and numbered wiring is used for easy component identification.



Durable Design

Durability has been designed into the machine by offering protection to features such as the rear lights, loader arm and coupler greasing points.

Quality Throughout

High quality solid plastics, well-fitted rubber moldings make up the foundation of the M Series cab. Robust switches are used throughout, ensuring long life of components.

Options

Customize your machine to meet your needs.

Configure the Machine the Way You Want It

A variety of options are available on the Cat M Series Compact Wheel Loaders to suit your specific operator comfort and application needs. See your Cat dealer for more information about the features below and additional options.



Coupler Options



Turbine Precleaner

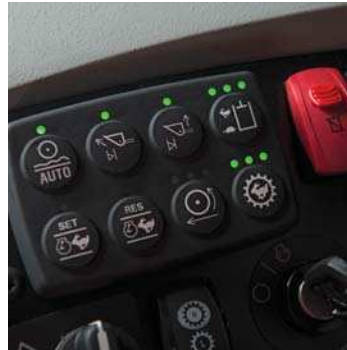

Road and Load Options



Additional Lights



Air Conditioning



Machine Security



Flexport™ Tires



Windshield Guard



High Flow Auxiliary Hydraulics



ECO Drains



Work Tool Electrical Harness



Product Link™

Serviceability

Easy service to keep your machine working.

All service points are easily accessible. The rear hoods large opening allows for easy access to the engine which features all service points located on one side for easy maintenance. Extended service intervals reduce service time and maximize uptime. Additional service features include:

- Remote mounted fuel and hydraulic filters.
- Convenient access door for coolant fill.
- Caterpillar electric fuel priming pump for ease of service.
- Easy access to battery terminals for jump starts.
- Ground level access to all routine maintenance items.
- Easy access to hydraulic and engine coolers, which can be separated for quick cleanout.
- Product Link™ ready (standard).

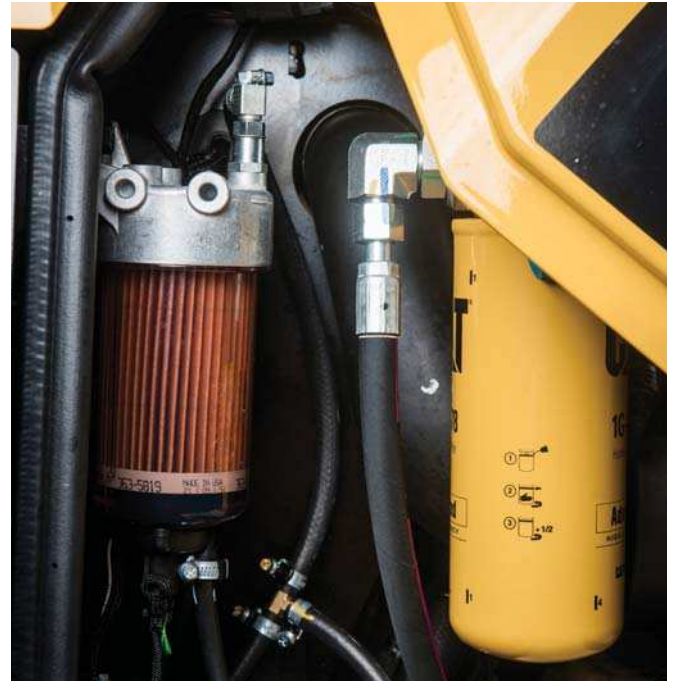

Customer Support

Unmatched support makes the difference.



Renowned Cat Dealer Support

Your Cat dealer is ready to help you every step of the way. From new or used machine sales, to rental or rebuild options, your Cat dealer can provide an optimal solution to your business needs.

Unsurpassed worldwide parts availability, trained technicians and customer support agreements maximize your machine uptime.

For more information on Cat products, dealer services and industry solutions, visit us at www.cat.com.

906M, 907M, 908M Compact Wheel Loader Specifications

Engine

906M, 907M, 908M

Engine model	Cat C3.3B	
Maximum gross power		
ISO 14396	54.6 kW	73 hp
Rated net power @ 2,400 rpm		
SAE J1349	54.7 kW	73 hp
ISO 9249 (1977)/EEC 80/1269	55.3 kW	74 hp
Maximum gross torque		
ISO 14396	261 N·m	192 lbf·ft
Maximum net torque		
SAE J1349	257 N·m	189 lbf·ft
ISO 9249 (1977)/EEC 80/1269	260 N·m	191 lbf·ft
Displacement	3.3 L	201 in ³
Bore	94 mm	3.7 in
Stroke	120 mm	4.7 in

- Net power ratings are tested at the reference conditions for the specified standard.
- Net power shown is the power available at the flywheel when the engine is equipped with alternator, air cleaner, diesel exhaust filter, and fan at minimum speed.
- No derating required up to 3000 m (10,000 ft) altitude. Auto derate protects hydraulic and transmission systems.
- Flywheel per the SAE reference conditions with the fan at maximum speed.
- The Cat C3.3B engine meets Tier 4 Final/Stage IIIB emission standards or Tier 4 Interim/Stage IIIA equivalent emission standards.
- The Cat C3.3B Tier 4 Final/Stage IIIB uses an active regeneration system which requires no operator interaction under normal conditions.

Engine Power and Torque

906M, 907M, 908M

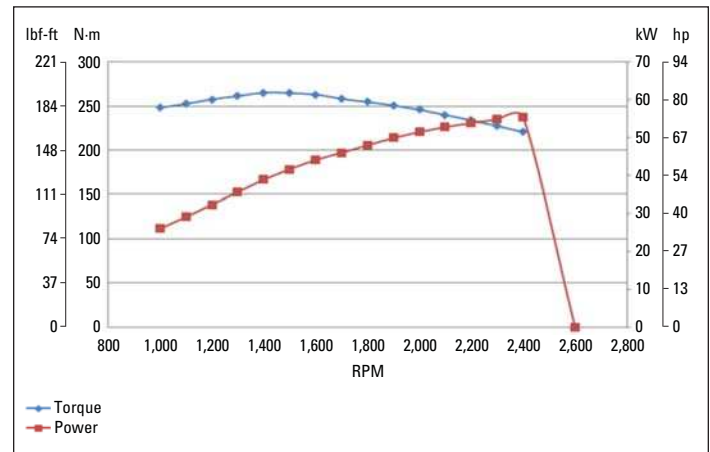

Buckets

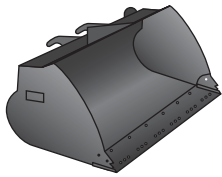

	906M		907M		908M	
General purpose	0.9 m ³	1.2 yd ³	1.0 m ³	1.31 yd ³	1.1-1.3 m ³	1.44-1.7 yd ³
Light material	1.2 m ³	1.57 yd ³	1.2 m ³	1.57 yd ³	1.5 m ³	1.96 yd ³

906M, 907M, 908M Compact Wheel Loader Specifications

Weights

	906M		907M		908M	
Operating weight	5595 kg	12,331 lb	5783 kg	12,745 lb	6364 kg	14,026 lb

- Specifications shown are for a machine configured with general purpose buckets, bolt-on cutting edges, 75 kg (165 lb) operator, Dunlop 405/70 SPT9 tires, full fuel, comfort EROPS cab, standard flow hydraulics and skid-steer coupler.
 - 906M is configured with a 0.9 m³ (1.2 yd³) bucket with bolt-on cutting edge.
 - 907M is configured with a 1.0 m³ (1.31 yd³) bucket with bolt-on cutting edge.
 - 908M is configured with a 1.1 m³ (1.44 yd³) bucket with bolt-on cutting edge.

Steering

	906M		907M		908M	
Steering articulation angle each direction	39°		39°		39°	
Steering cylinder: double acting						
Bore diameter	80 mm	3.1 in	80 mm	3.1 in	80 mm	3.1 in
Rod diameter	35 mm	1.4 in	35 mm	1.4 in	35 mm	1.4 in
Stroke	300 mm	11.8 in	300 mm	11.8 in	300 mm	11.8 in
Nominal flow – steering pump	43.9 L/min	12 gal/min	43.9 L/min	12 gal/min	43.9 L/min	12 gal/min
Maximum working pressure – steering pump	22 000 kPa	3,191 psi	22 000 kPa	3,191 psi	22 000 kPa	3,191 psi
Maximum steering torque						
0° (straight machine)	50 375 N·m	37,155 lbf-ft	50 375 N·m	37,155 lbf-ft	57 630 N·m	42,506 lbf-ft
39° (full turn)	37 620 N·m	27,747 lbf-ft	37 620 N·m	27,747 lbf-ft	42 570 N·m	31,398 lbf-ft
Steering cycle times (full left to full right)						
2,620 rpm	3 seconds		3 seconds		3 seconds	
Number of steering wheel turns						
Full left to full right or full right to full left	<6 turns		<6 turns		<6 turns	

Service Refill Capacities

	906M		907M		908M	
Fuel tank	52 L	13.7 gal	78 L	20.6 gal	78 L	20.6 gal
Cooling system	16.5 L	4.4 gal	17 L	4.5 gal	16.5 L	4.4 gal
Engine crankcase	11.2 L	3 gal	11.2 L	3 gal	11.2 L	3 gal
Transmission (gear box)	8.5 L	2.2 gal	8.5 L	2.2 gal	11 L	2.9 gal
Axles						
Front	N/A	N/A	N/A	N/A	N/A	N/A
Rear	N/A	N/A	N/A	N/A	N/A	N/A
Hydraulic system (including tank)	70 L	18.5 gal	70 L	18.5 gal	72 L	19 gal
Hydraulic tank	46 L	12.2 gal	46 L	12.2 gal	46 L	12.2 gal

906M, 907M, 908M Compact Wheel Loader Specifications

Loader Hydraulic System

	906M		907M		908M	
Maximum flow – implement pump	73 L/min	19 gal/min	73 L/min	19 gal/min	82 L/min	22 gal/min
Auxiliary function standard flow	73 L/min	19 gal/min	73 L/min	19 gal/min	82 L/min	22 gal/min
Auxiliary function high flow	116 L/min	31 gal/min	116 L/min	31 gal/min	126 L/min	33 gal/min
Maximum working pressure – implement pump	23 500 kPa	3,408 psi	23 500 kPa	3,408 psi	23 500 kPa	3,408 psi
Relief pressure – tilt cylinder head	31 000 kPa	4,496 psi	31 000 kPa	4,496 psi	31 000 kPa	4,496 psi
Relief pressure – tilt cylinder rod	19 000 kPa	2,756 psi	19 000 kPa	2,756 psi	19 000 kPa	2,756 psi
3rd function maximum working pressure	23 500 kPa	3,408 psi	23 500 kPa	3,408 psi	23 500 kPa	3,408 psi
Boost flow maximum pressure	22 000 kPa	3,191 psi	22 000 kPa	3,191 psi	22 000 kPa	3,191 psi
Lift cylinder: double acting						
Bore diameter	75 mm	3 in	75 mm	3 in	85 mm	3.3 in
Rod diameter	50 mm	2 in	50 mm	2 in	50 mm	2 in
Stroke	695 mm	27.4 in	695 mm	27.4 in	699 mm	27.5 in
Tilt cylinder: double acting						
Bore diameter	90 mm	3.5 in	90 mm	3.5 in	100 mm	3.9 in
Rod diameter	55 mm	2.2 in	55 mm	2.2 in	55 mm	2.2 in
Stroke	417 mm	16.4 in	417 mm	16.4 in	416 mm	16.4 in
Hydraulic cycle times (1,800 rpm)						
Raise (ground level to maximum lift)	5.5 seconds		5.5 seconds		5.5 seconds	
Dump (at maximum lift height)	1.5 seconds		1.5 seconds		1.5 seconds	
Float down (maximum lift to ground level)	2.6 seconds		2.6 seconds		2.6 seconds	
Total cycle time	9.6 seconds		9.6 seconds		9.6 seconds	
Hydraulic cycle times (1,000 rpm)						
Raise (ground level to maximum lift)	9.6 seconds		9.6 seconds		9.6 seconds	
Dump (at maximum lift height)	3 seconds		3 seconds		3 seconds	
Float down (maximum lift to ground level)	2.6 seconds		2.6 seconds		2.6 seconds	

Drive Train

	906M		907M		908M	
Forward						
Range 1	10 km/h	6 mph	10 km/h	6 mph	10 km/h	6 mph
Range 2	20 km/h	12 mph	20 km/h	12 mph	20 km/h	12 mph
High range	35 km/h	22 mph	35 km/h	22 mph	35 km/h	22 mph
Reverse						
Range 1	10 km/h	6 mph	10 km/h	6 mph	10 km/h	6 mph
Range 2	20 km/h	12 mph	20 km/h	12 mph	20 km/h	12 mph
High range	35 km/h	22 mph	35 km/h	22 mph	35 km/h	22 mph

906M, 907M, 908M Compact Wheel Loader Specifications

Tires

	906M	907M	908M
335/80 R18 XZSL Michelin	Yes	Yes	
340/80 R18 AT-R Firestone	Yes	Yes	
340/80 R18 XMCL Michelin	Yes	Yes	
340/80 R18 TRI2 Nokian	Yes	Yes	
340/80 R18 Bibload Michelin	Yes	Yes	
405/70 R18 SPT9 Dunlop*	Yes	Yes	
12.5/80 R18 Flexport™	Yes	Yes	
360/80 R20 TRI2 Nokian			Yes
375/75 R20 XZSL Michelin			Yes
400/70 R20 XMCL Michelin			Yes
400/70 R20 Bibload Michelin			Yes
405/70 R20 SPT9 Dunlop			Yes
12.5-20 ATU Firestone			Yes

*Standard tire.

- Other tire choices available, contact your Cat dealer for details.
- In certain applications, the loader's productive capabilities may exceed the tires' tonnes-km/h (ton-mph) capabilities.
- Caterpillar recommends that you consult a tire supplier to evaluate all conditions before selecting a tire model.

Cab



- ROPS: SAE J1040 MAY94, ISO 3471-1994.
- FOPS: SAE J/ISO 3449 APR98, Level II, ISO 3449 1992 Level II.
- Cat cab and Rollover Protective Structures (ROPS) are standard in North America and Europe.
- When properly installed and maintained, the cab offered by Caterpillar, when tested with doors, and windows closed as per work cycle procedures specified in ISO 6395 2008, results in operator sound exposure Leq (Equivalent sound pressure level) of 66 dB(A) typical.

Operating Specifications

	906M		907M		908M	
Tipping load – straight (ISO 14397-1)	3932 kg	8,666 lb	4087 kg	9,007 lb	4427 kg	9,757 lb
Tipping load – full turn (ISO 14397-1)	3204 kg	7,061 lb	3330 kg	7,339 lb	3606 kg	7,947 lb
Clearance: full lift and 45° dump	2513 mm	8'2"	2429 mm	7'11"	2463 mm	8'0"
Reach: full lift and 45° dump	714 mm	2'4"	792 mm	2'7"	931 mm	3'0"
Steering articulation angle each direction	39°		39°		39°	

906M, 907M, 908M Compact Wheel Loader Specifications

Dimensions with Bucket

All dimensions are approximate. Dimensions will vary with bucket and tire choice. Refer to Operating Specifications with Buckets.

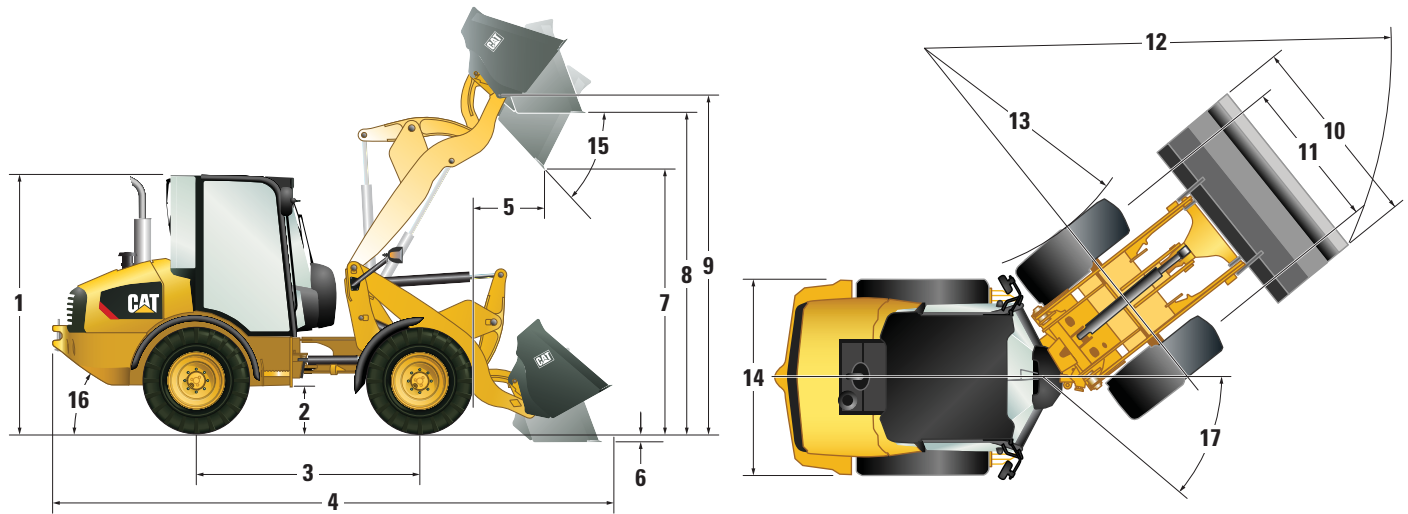

Standard Lift – with ISO Coupler

	906M		907M		908M	
** 1 Height: ground to cab	2463 mm	8'1"	2586 mm	8'5"	2650 mm	8'8"
** 2 Height: ground clearance	300 mm	11"	300 mm	11"	340 mm	1'1"
3 Length: wheel base	2170 mm	7'1"	2170 mm	7'1"	2170 mm	7'1"
* 4 Length: overall	5469 mm	17'11"	5469 mm	17'11"	5630 mm	18'5"
* 5 Reach: bucket at 45°	725 mm	2'4"	725 mm	2'4"	770 mm	2'6"
** 6 Dig depth	95 mm	3.7"	95 mm	3.7"	101 mm	3.9"
* 7 Clearance: bucket at 45°	2478 mm	8'1"	2478 mm	8'1"	2620 mm	8'7"
** 8 Clearance: level bucket	3027 mm	9'11"	3027 mm	9'11"	3215 mm	10'6"
** 9 Height: bucket pin	3227 mm	10'7"	3227 mm	10'7"	3410 mm	11'2"
10 Width: bucket	1890 mm	6'2"	2045 mm	6'8"	2080 mm	6'9"
11 Width: tread center	1420 mm	4'7"	1420 mm	4'7"	1570 mm	5'1"
12 Turning radius: over bucket	4420 mm	14'6"	4489 mm	14'8"	4530 mm	14'10"
13 Turning radius: inside of tires	2240 mm	7'4"	2240 mm	7'4"	2080 mm	6'9"
14 Machine width	1840 mm	6'0"	1840 mm	6'0"	1985 mm	6'6"
15 Dump angle at full lift	45°		45°		45°	
16 Departure angle	33°		33°		33°	
17 Articulation angle	39°		39°		39°	
Operating weight	5670 kg	12,496 lb	5859 kg	12,913 lb	6499 kg	14,323 lb

*Vary with bucket.

**Vary with tire.

Dimensions listed are for a machine configured with general purpose buckets, bolt-on cutting edges, 75 kg (165 lb) operator, no air conditioner and Dunlop 405/70 SPT9 tires.

906M, 907M, 908M Compact Wheel Loader Specifications

Dimensions with Bucket

All dimensions are approximate. Dimensions will vary with bucket and tire choice. Refer to Operating Specifications with Buckets.

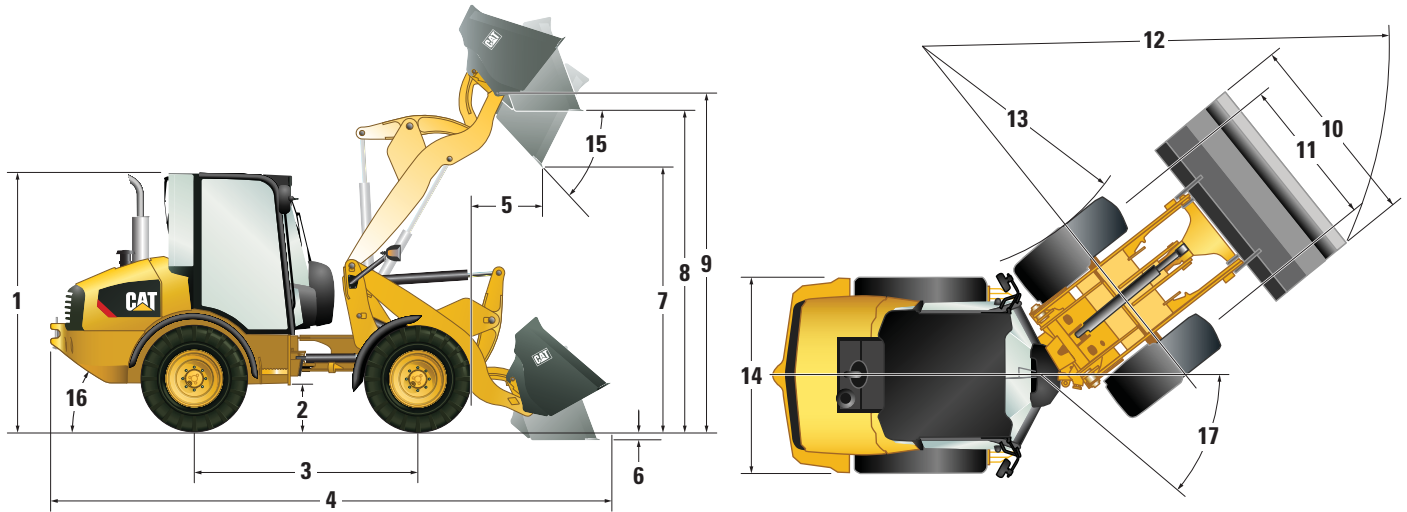

Standard Lift – with SSL Coupler

	906M		907M		908M	
** 1 Height: ground to cab	2463 mm	8'1"	2586 mm	8'5"	2650 mm	8'8"
** 2 Height: ground clearance	300 mm	11"	300 mm	11"	340 mm	1'1"
3 Length: wheel base	2170 mm	7'1"	2170 mm	7'1"	2170 mm	7'1"
* 4 Length: overall	5620 mm	18'5"	5620 mm	18'5"	5780 mm	18'11"
* 5 Reach: bucket at 45°	820 mm	2'8"	820 mm	2'8"	866 mm	2'10"
** 6 Dig depth	107 mm	4.2"	107 mm	4.2"	109 mm	4.2"
* 7 Clearance: bucket at 45°	2359 mm	7'8"	2359 mm	7'8"	2505 mm	8'2"
** 8 Clearance: level bucket	3035 mm	9'11"	3035 mm	9'11"	3215 mm	10'6"
** 9 Height: bucket pin	3227 mm	10'7"	3227 mm	10'7"	3410 mm	11'2"
10 Width: bucket	1890 mm	6'2"	2045 mm	6'8"	2080 mm	6'9"
11 Width: tread center	1420 mm	4'7"	1420 mm	4'7"	1570 mm	5'1"
12 Turning radius: over bucket	4464 mm	14'7"	4473 mm	14'8"	4534 mm	14'10"
13 Turning radius: inside of tires	2240 mm	7'4"	2240 mm	7'4"	2080 mm	6'9"
14 Machine width	1840 mm	6'0"	1840 mm	6'0"	1985 mm	6'6"
15 Dump angle at full lift	45°		45°		45°	
16 Departure angle	33°		33°		33°	
17 Articulation angle	39°		39°		39°	
Operating weight	5663 kg	12,481 lb	5859 kg	12,913 lb	6497 kg	14,319 lb

*Vary with bucket.

**Vary with tire.

Dimensions listed are for a machine configured with general purpose buckets, bolt-on cutting edges, 75 kg (165 lb) operator, no air conditioner and Dunlop 405/70 SPT9 tires.

906M, 907M, 908M Compact Wheel Loader Specifications

906M Supplemental Operating Data – Tires

	Michelin Bibload		Nokian		Flexport	
	mm	in	mm	in	mm	in
Vertical heights	-6 mm	-0.2 in	-8 mm	-0.3 in	+14 mm	+0.6 in
Reach: bucket at 45°	+18 mm	+0.7 in	+13 mm	+0.5 in	+28 mm	+1.1 in
Width: over tires	+1 mm	+0 in	+0 mm	+0 in	-2 mm	-0.1 in
Turning radius: inside of tires	-0 mm	-0 in	-0 mm	-0 in	+1 mm	+0 in
Tipping load – straight	-21 kg	-46 lb	-5 kg	-11 lb	+301 kg	+663 lb
Tipping load – full turn	-18 kg	-40 lb	-5 kg	-11 lb	+245 kg	+540 lb
Operating weight	-36 kg	-79 lb	-10 kg	-22 lb	+505 kg	+1,113 lb

907M Supplemental Operating Data – Tires

	Michelin Bibload		Nokian		Flexport	
	mm	in	mm	in	mm	in
Vertical heights	-6 mm	-0.2 in	-8 mm	-0.3 in	+14 mm	+0.6 in
Reach: bucket at 45°	+18 mm	+0.7 in	+13 mm	+0.5 in	+28 mm	+1.1 in
Width: over tires	+1 mm	+0 in	+0 mm	+0 in	-2 mm	-0.1 in
Turning radius: inside of tires	-0 mm	-0 in	-0 mm	-0 in	+1 mm	+0 in
Tipping load – straight	-21 kg	-46 lb	-6 kg	-13 lb	+301 kg	+663 lb
Tipping load – full turn	-18 kg	-40 lb	-5 kg	-11 lb	+245 kg	+540 lb
Operating weight	-36 kg	-79 lb	-10 kg	-22 lb	+505 kg	+1,113 lb

908M Supplemental Operating Data – Tires

	Michelin Bibload		Nokian	
	mm	in	mm	in
Vertical heights	-12 mm	-0.5 in	+8 mm	+0.3 in
Reach: bucket at 45°	+18 mm	+0.7 in	+0 mm	+0 in
Width: over tires	+0 mm	+0 in	+4 mm	+0.2 in
Turning radius: inside of tires	-0 mm	-0 in	+2 mm	+0.1 in
Tipping load – straight	-5 kg	-11 lb	-31 kg	-68 lb
Tipping load – full turn	-3 kg	-7 lb	-25 kg	-55 lb
Operating weight	-8 kg	-18 lb	-56 kg	-123 lb

906M Operating Specifications with Hook On Buckets

		General Purpose							
		Horizontal Pin (HPL – ISO)			Vertical Pin			Horizontal Pin (HPL – A)	
		Base Edge	Bolt-on Edge	Bolt-on Teeth	Base Edge	Bolt-on Edge	Bolt-on Teeth	Bolt-on Edge	Bolt-on Teeth
Rated capacity	m ³	0.9	0.9	0.9	0.9	0.9	0.9	0.9	0.9
	yd ³	1.2	1.2	1.2	1.2	1.2	1.2	1.2	1.2
Width: bucket	mm	1880	1880	1880	1880	1880	1880	1880	1880
	ft/in	6'2"	6'2"	6'2"	6'2"	6'2"	6'2"	6'2"	6'2"
Nominal material density, 100% fill factor	kg/m ³	1982	1909	1954	1868	1780	1820	1903	1948
	lb/yd ³	3,276	3,156	3,230	3,088	2,942	3,008	3,146	3,220
Clearance: full lift, 45° dump	mm	2513	2478	2513	2393	2359	2393	2478	2513
	ft/in	8'2"	8'1"	8'2"	7'10"	7'8"	7'10"	8'1"	8'2"
Reach: full lift, 45° dump	mm	714	725	714	809	820	809	725	714
	ft/in	2'4"	2'4"	2'4"	2'7"	2'8"	2'7"	2'4"	2'4"
Reach: level arm, level bucket	mm	1851	1883	1851	2000	2033	2000	1883	1851
	ft/in	6'0"	6'2"	6'0"	6'6"	6'8"	6'6"	6'2"	6'0"
Dig depth	mm	79	95	79	91	107	91	95	79
	in	3.1	3.7	3.1	3.6	4.2	3.6	3.7	3.1
Length: overall	mm	5436	5469	5538	5586	5620	5690	5469	5538
	ft/in	17'10"	17'11"	18'2"	18'3"	18'5"	18'8"	17'11"	18'2"
Turning radius, bucket at carry	mm	4401	4420	4401	4445	4464	4445	4420	4401
	ft/in	14'5"	14'6"	14'5"	14'7"	14'7"	14'7"	14'6"	14'5"
Tipping load – straight, ISO 14397-1*	kg	4380	4219	4317	4128	3932	4021	4206	4304
	lb	9,653	9,298	9,514	9,098	8,666	8,862	9,270	9,486
Tipping load – full turn, ISO 14397-1*	kg	3568	3437	3517	3363	3204	3276	3426	3506
	lb	7,863	7,575	7,751	7,412	7,061	7,220	7,550	7,727
Breakout force	kN	52	52	52	43	43	43	50	50
	lbf	11,689	11,689	11,689	9,666	9,666	9,666	11,240	11,240
Operating weight	kg	5545	5581	5559	5560	5595	5573	5592	5569
	lb	12,221	12,300	12,252	12,254	12,331	12,282	12,324	12,274

*Full compliance to ISO 14397-1 (2007) Sections 1 thru 6, which requires 2% verification between calculation and testing.

Dimensions listed are for a machine configured with general purpose buckets, bolt-on cutting edges, 75 kg (165 lb) operator, no air conditioner and Dunlop 405/70 SPT9 tires.

Bucket Specifications

906M Operating Specifications with Hook On Buckets

		Multi Purpose							
		Horizontal Pin (HPL – ISO)			Vertical Pin			Horizontal Pin (HPL – A)	
		Base Edge	Bolt-on Edge	Bolt-on Teeth	Base Edge	Bolt-on Edge	Bolt-on Teeth	Bolt-on Edge	Bolt-on Teeth
Rated capacity	m ³	0.7	0.7	0.7	0.7	0.7	0.7	0.75	0.75
	yd ³	0.9	0.9	0.9	0.9	0.9	0.9	1.0	1.0
Width: bucket	mm	1880	1880	1880	1880	1880	1880	1880	1880
	ft/in	6'2"	6'2"	6'2"	6'2"	6'2"	6'2"	6'2"	6'2"
Nominal material density, 100% fill factor	kg/m ³	2495	2391	2437	2435	2333	2378	2225	2267
	lb/yd ³	4,277	4,009	4,178	4,174	3,999	4,076	3,677	3,748
Clearance: full lift, 45° dump	mm	2500	2465	2500	2468	2434	2468	2465	2500
	ft/in	8'2"	8'1"	8'2"	8'1"	7'11"	8'1"	8'1"	8'2"
Reach: full lift, 45° dump	mm	704	715	704	758	770	758	715	704
	ft/in	2'3"	2'4"	2'3"	2'5"	2'6"	2'5"	2'4"	2'3"
Reach: level arm, level bucket	mm	1858	1891	1858	1919	1952	1919	1891	1858
	ft/in	6'1"	6'2"	6'1"	6'3"	6'4"	6'3"	6'2"	6'1"
Dig depth	mm	79	95	79	91	107	91	95	79
	in	3.1	3.7	3.1	3.6	4.2	3.6	3.7	3.1
Length: overall	mm	5436	5469	5538	5586	5620	5599	5469	5538
	ft/in	17'10"	17'11"	18'2"	18'3"	18'5"	18'4"	17'11"	18'2"
Turning radius, bucket at carry	mm	4406	4424	4406	4416	4434	4416	4424	4406
	ft/in	14'5"	14'6"	14'5"	14'5"	14'6"	14'5"	14'6"	14'5"
Tipping load – straight, ISO 14397-1*	kg	4288	4110	4188	4184	4009	4086	4096	4174
	lb	9,450	9,058	9,230	9,221	8,835	9,005	9,027	9,199
Tipping load – full turn, ISO 14397-1*	kg	3493	3348	3412	3409	3266	3329	3337	3401
	lb	7,698	7,378	7,520	7,513	7,198	7,337	7,354	7,495
Breakout force	kN	52	52	52	43	43	43	50	50
	lbf	11,689	11,689	11,689	9,666	9,666	9,666	11,240	11,240
Operating weight	kg	5707	5772	5750	5701	5765	5742	5782	5760
	lb	12,578	12,721	12,673	12,565	12,706	12,655	12,743	12,695

*Full compliance to ISO 14397-1 (2007) Sections 1 thru 6, which requires 2% verification between calculation and testing.

Dimensions listed are for a machine configured with general purpose buckets, bolt-on cutting edges, 75 kg (165 lb) operator, no air conditioner and Dunlop 405/70 SPT9 tires.

906M Operating Specifications with Hook On Buckets

		Light Material		Industrial Grapple
		Horizontal Pin	Vertical Pin	Vertical Pin
		Bolt-on Edge	Bolt-on Edge	Bolt-on Edge
Rated capacity	m ³	1.2	1.2	N/A
	yd ³	1.6	1.6	N/A
Width: bucket	mm	2080	2080	2057
	ft/in	6'9"	6'9"	6'8"
Nominal material density, 100% fill factor	kg/m ³	1381	1288	N/A
	lb/yd ³	2,283	2,129	N/A
Clearance: full lift, 45° dump	mm	2429	2395	2439
	ft/in	7'11"	7'10"	8'0"
Reach: full lift, 45° dump	mm	792	803	865
	ft/in	2'7"	2'8"	2'10"
Reach: level arm, level bucket	mm	1994	2144	2011
	ft/in	6'6"	7'0"	6'7"
Dig depth	mm	83	104	12
	in	3.3	4.1	0.5
Length: overall	mm	5580	5730	5596
	ft/in	18'3"	18'9"	18'4"
Turning radius, bucket at carry	mm	4521	4566	4498
	ft/in	14'9"	14'11"	14'9"
Tipping load – straight, ISO 14397-1*	kg	4068	3796	3817
	lb	8,965	8,366	8,412
Tipping load – full turn, ISO 14397-1*	kg	3314	3092	3109
	lb	7,304	6,814	6,852
Operating weight	kg	5649	5663	5865
	lb	12,450	12,481	12,926

*Full compliance to ISO 14397-1 (2007) Sections 1 thru 6, which requires 2% verification between calculation and testing.

Dimensions listed are for a machine configured with general purpose buckets, bolt-on cutting edges, 75 kg (165 lb) operator, no air conditioner and Dunlop 405/70 SPT9 tires.

Bucket Specifications

907M Operating Specifications with Hook On Buckets

		General Purpose							
		Horizontal Pin (HPL – ISO)			Vertical Pin			Horizontal Pin (HPL – A)	
		Base Edge	Bolt-on Edge	Bolt-on Teeth	Base Edge	Bolt-on Edge	Bolt-on Teeth	Bolt-on Edge	Bolt-on Teeth
Rated capacity	m ³	1.0	1.0	1.0	1.0	1.0	1.0	1.1	1.1
	yd ³	1.3	1.3	1.3	1.3	1.3	1.3	1.4	1.4
Width: bucket	mm	2035	2035	2035	2035	2035	2035	1880	1880
	ft/in	6'8"	6'8"	6'8"	6'8"	6'8"	6'8"	6'2"	6'2"
Nominal material density, 100% fill factor	kg/m ³	1857	1786	1824	1729	1665	1699	1592	1632
	lb/yd ³	3,147	3,027	3,092	2,930	2,823	2,880	2,757	2,826
Clearance: full lift, 45° dump	mm	2513	2478	2513	2393	2359	2393	2478	2513
	ft/in	8'2"	8'1"	8'2"	7'10"	7'8"	7'10"	8'1"	8'2"
Reach: full lift, 45° dump	mm	714	725	714	809	820	809	725	714
	ft/in	2'4"	2'4"	2'4"	2'7"	2'8"	2'7"	2'4"	2'4"
Reach: level arm, level bucket	mm	1851	1883	1851	2000	2033	2000	1883	1851
	ft/in	6'0"	6'2"	6'0"	6'6"	6'8"	6'6"	6'2"	6'0"
Dig depth	mm	79	95	79	91	107	91	95	79
	in	3.1	3.7	3.1	3.6	4.2	3.6	3.7	3.1
Length: overall	mm	5436	5469	5538	5586	5620	5690	5469	5538
	ft/in	17'10"	17'11"	18'2"	18'3"	18'5"	18'8"	17'11"	18'2"
Turning radius, bucket at carry	mm	4473	4489	4473	4515	4534	4515	4420	4401
	ft/in	14'8"	14'8"	14'8"	14'9"	14'10"	14'9"	14'6"	14'5"
Tipping load – straight, ISO 14397-1*	kg	4558	4384	4478	4244	4087	4172	4300	4408
	lb	10,045	9,662	9,869	9,353	9,007	9,195	9,477	9,715
Tipping load – full turn, ISO 14397-1*	kg	3713	3571	3648	3457	3330	3398	3503	3591
	lb	8,183	7,870	8,040	7,619	7,339	7,489	7,720	7,914
Breakout force	kN	52	52	52	43	43	43	50	50
	lbf	11,689	11,689	11,689	9,666	9,666	9,666	11,240	11,240
Operating weight	kg	5691	5730	5709	5706	5744	5723	5810	5784
	lb	12,542	12,628	12,582	12,576	12,659	12,613	12,805	12,747

*Full compliance to ISO 14397-1 (2007) Sections 1 thru 6, which requires 2% verification between calculation and testing.

Dimensions listed are for a machine configured with general purpose buckets, bolt-on cutting edges, 75 kg (165 lb) operator, no air conditioner and Dunlop 405/70 SPT9 tires.

907M Operating Specifications with Hook On Buckets

		Multi Purpose							
		Horizontal Pin (HPL – ISO)			Vertical Pin			Horizontal Pin (HPL – A)	
		Base Edge	Bolt-on Edge	Bolt-on Teeth	Base Edge	Bolt-on Edge	Bolt-on Teeth	Bolt-on Edge	Bolt-on Teeth
Rated capacity	m ³	0.75	0.75	0.75	0.75	0.75	0.75	0.75	0.75
	yd ³	1.0	1.0	1.0	1.0	1.0	1.0	1.0	1.0
Width: bucket	mm	1880	1880	1880	1880	1880	1880	1890	1880
	ft/in	6'2"	6'2"	6'2"	6'2"	6'2"	6'2"	6'2"	6'2"
Nominal material density, 100% fill factor	kg/m ³	2429	2331	2374	2371	2273	2317	2337	2381
	lb/yd ³	4,016	3,853	3,924	3,920	3,758	3,829	3,863	3,935
Clearance: full lift, 45° dump	mm	2500	2465	2500	2468	2434	2468	2465	2500
	ft/in	8'2"	8'1"	8'2"	8'1"	7'11"	8'1"	8'1"	8'2"
Reach: full lift, 45° dump	mm	704	715	704	758	770	758	715	704
	ft/in	2'3"	2'4"	2'3"	2'5"	2'6"	2'5"	2'4"	2'3"
Reach: level arm, level bucket	mm	1858	1891	1858	1919	1952	1919	1891	1858
	ft/in	6'1"	6'2"	6'1"	6'3"	6'4"	6'3"	6'2"	6'1"
Dig depth	mm	79	95	79	91	107	91	106	90
	in	3.1	3.7	3.1	3.6	4.2	3.6	4.2	3.5
Length: overall	mm	5436	5469	5538	5586	5620	5599	5469	5436
	ft/in	17'10"	17'11"	18'2"	18'3"	18'5"	18'4"	17'11"	17'10"
Turning radius, bucket at carry	mm	4406	4424	4406	4416	4434	4416	4424	4406
	ft/in	14'5"	14'6"	14'5"	14'5"	14'6"	14'5"	14'6"	14'5"
Tipping load – straight, ISO 14397-1*	kg	4473	4291	4382	4366	4186	4265	4303	4384
	lb	9,858	9,457	9,657	9,622	9,225	9,400	9,483	9,662
Tipping load – full turn, ISO 14397-1*	kg	3644	3496	3561	3557	3410	3475	3505	3571
	lb	8,031	7,705	7,848	7,839	7,515	7,658	7,725	7,870
Breakout force	kN	52	52	52	43	43	43	50	50
	lbf	11,689	11,689	11,689	9,666	9,666	9,666	11,240	11,240
Operating weight	kg	5838	5903	5881	5832	5896	5873	5951	5928
	lb	12,866	13,010	12,961	12,853	12,994	12,944	13,116	13,065

*Full compliance to ISO 14397-1 (2007) Sections 1 thru 6, which requires 2% verification between calculation and testing.

Dimensions listed are for a machine configured with general purpose buckets, bolt-on cutting edges, 75 kg (165 lb) operator, no air conditioner and Dunlop 405/70 SPT9 tires.

Bucket Specifications

907M Operating Specifications with Hook On Buckets

		Light Material		Industrial Grapple
		Horizontal Pin	Vertical Pin	Vertical Pin
		Bolt-on Edge	Bolt-on Edge	Bolt-on Edge
Rated capacity	m ³	1.2	1.2	N/A
	yd ³	1.6	1.6	N/A
Width: bucket	mm	2080	2080	2057
	ft/in	6'9"	6'9"	6'8"
Nominal material density, 100% fill factor	kg/m ³	1400	1345	N/A
	lb/yd ³	2,380	2,223	N/A
Clearance: full lift, 45° dump	mm	2429	2395	2439
	ft/in	7'11"	7'10"	8'0"
Reach: full lift, 45° dump	mm	792	803	865
	ft/in	2'7"	2'8"	2'10"
Reach: level arm, level bucket	mm	1994	2144	2011
	ft/in	6'6"	7'0"	6'7"
Dig depth	mm	83	104	12
	in	3.3	4.1	0.5
Length: overall	mm	5580	5730	5596
	ft/in	18'3"	18'9"	18'4"
Turning radius, bucket at carry	mm	4521	4566	4498
	ft/in	14'9"	14'11"	14'9"
Tipping load – straight, ISO 14397-1*	kg	4243	3961	3991
	lb	9,351	8,730	8,796
Tipping load – full turn, ISO 14397-1*	kg	3456	3227	3251
	lb	7,617	7,112	7,165
Operating weight	kg	5779	5794	5996
	lb	12,736	12,769	13,215

*Full compliance to ISO 14397-1 (2007) Sections 1 thru 6, which requires 2% verification between calculation and testing.

Dimensions listed are for a machine configured with general purpose buckets, bolt-on cutting edges, 75 kg (165 lb) operator, no air conditioner and Dunlop 405/70 SPT9 tires.

908M Operating Specifications with Hook On Buckets

		General Purpose									
		Horizontal Pin (HPL – ISO)					Vertical Pin			Horizontal Pin (HPL – A)	
		Base Edge	Bolt-on Edge	Bolt-on Teeth	Bolt-on Teeth	Bolt-on Edge	Base Edge	Bolt-on Edge	Bolt-on Teeth	Bolt-on Edge	Bolt-on Teeth
Rated capacity	m ³	1.1	1.1	1.1	1.3	1.3	1.1	1.1	1.1	1.3	1.3
	yd ³	1.4	1.4	1.4	1.7	1.7	1.4	1.4	1.4	1.7	1.7
Width: bucket	mm	2060	2060	2060	2060	2060	2060	2060	2060	2060	2060
	ft/in	6'9"	6'9"	6'9"	6'9"	6'9"	6'9"	6'9"	6'9"	6'9"	6'9"
Nominal material density, 100% fill factor	kg/m ³	1810	1747	1788	1448	1481	1696	1639	1676	1445	1478
	lb/yd ³	3,134	3,026	3,096	2,440	2,496	2,937	2,838	2,902	2,435	2,490
Clearance: full lift, 45° dump	mm	1810	1747	1788	1448	1481	1696	1639	1676	1445	1478
	ft/in	3,134	3,026	3,096	2,440	2,496	2,937	2,838	2,902	2,435	2,490
Reach: full lift, 45° dump	mm	757	770	757	757	770	854	866	854	846	834
	ft/in	2'5"	2'6"	2'5"	2'5"	2'6"	2'9"	2'10"	2'9"	2'9"	2'8"
Reach: level arm, level bucket	mm	1999	2031	1999	1999	2031	2149	2181	2149	2136	2103
	ft/in	6'6"	6'7"	6'6"	6'6"	6'7"	7'0"	7'1"	7'0"	7'0"	6'10"
Dig depth	mm	85	101	85	85	101	93	109	93	101	85
	in	3.3	4.0	3.3	3.3	4.0	3.7	4.3	3.7	4.0	3.3
Length: overall	mm	5598	5630	5699	5699	5630	5747	5780	5849	5763	5720
	ft/in	18'4"	18'5"	18'8"	18'8"	18'5"	18'10"	18'11"	19'2"	18'10"	18'9"
Turning radius, bucket at carry	mm	4511	4530	4511	4511	4530	4559	4579	4559	4636	4617
	ft/in	14'9"	14'10"	14'9"	14'9"	14'10"	14'11"	15'0"	14'11"	15'2"	15'1"
Tipping load – straight, ISO 14397-1*	kg	4888	4719	4828	4620	4727	4580	4427	4526	4610	4717
	lb	10,773	10,400	10,640	10,182	10,418	10,094	9,757	9,975	10,160	10,396
Tipping load – full turn, ISO 14397-1*	kg	3982	3844	3933	3764	3851	3731	3606	3687	3756	3842
	lb	8,776	8,472	8,668	8,295	8,487	8,223	7,947	8,126	8,278	8,467
Breakout force	kN	61	61	61	61	61	51	51	51	59	59
	lbf	13,712	13,712	13,712	13,712	13,712	11,464	11,464	11,464	13,263	13,263
Operating weight	kg	6311	6350	6324	6379	6353	6325	6364	6338	6390	6364
	lb	13,909	13,995	13,938	14,059	14,002	13,940	14,026	13,968	14,083	14,026

*Full compliance to ISO 14397-1 (2007) Sections 1 thru 6, which requires 2% verification between calculation and testing.

Dimensions listed are for a machine configured with general purpose buckets, bolt-on cutting edges, 75 kg (165 lb) operator, no air conditioner and Dunlop 405/70 SPT9 tires.

Bucket Specifications

908M Operating Specifications with Hook On Buckets

		Multi Purpose							
		Horizontal Pin (HPL – ISO)			Vertical Pin			Horizontal Pin (HPL – A)	
		Base Edge	Bolt-on Edge	Bolt-on Teeth	Base Edge	Bolt-on Edge	Bolt-on Teeth	Bolt-on Edge	Bolt-on Teeth
Rated capacity	m ³	0.9	0.9	0.9	0.9	0.9	0.9	0.9	0.9
	yd ³	1.2	1.2	1.2	1.2	1.2	1.2	1.2	1.2
Width: bucket	mm	2060	2060	2060	2060	2060	2060	2060	2060
	ft/in	6'9"	6'9"	6'9"	6'9"	6'9"	6'9"	6'9"	6'9"
Nominal material density, 100% fill factor	kg/m ³	2184	2098	2139	2137	2050	2090	2092	2133
	lb/yd ³	3,610	3,468	3,535	3,532	3,388	3,455	3,458	3,525
Clearance: full lift, 45° dump	mm	2665	2624	2665	2627	2593	2627	2630	2665
	ft/in	8'8"	8'7"	8'8"	8'7"	8'6"	8'7"	8'7"	8'8"
Reach: full lift, 45° dump	mm	737	748	737	788	800	788	748	737
	ft/in	2'5"	2'5"	2'5"	2'7"	2'7"	2'7"	2'5"	2'5"
Reach: level arm, level bucket	mm	1978	2010	1978	2039	2072	2039	2010	1978
	ft/in	6'5"	6'7"	6'5"	6'8"	6'9"	6'8"	6'7"	6'5"
Dig depth	mm	94	110	94	101	117	101	110	94
	in	3.7	4.3	3.7	4.0	4.6	4.0	4.3	3.7
Length: overall	mm	5576	5609	5678	5643	5670	5740	5609	5678
	ft/in	18'3"	18'4"	18'7"	18'6"	18'7"	18'9"	18'4"	18'7"
Turning radius, bucket at carry	mm	4509	4528	4509	4521	4540	4521	4528	4509
	ft/in	14'9"	14'10"	14'9"	14'9"	14'10"	14'9"	14'10"	14'9"
Tipping load – straight, ISO 14397-1*	kg	4825	4636	4726	4721	4530	4618	4622	4712
	lb	10,634	10,217	10,416	10,405	9,984	10,178	10,186	10,385
Tipping load – full turn, ISO 14397-1*	kg	3931	3776	3850	3846	3690	3762	3766	3839
	lb	8,663	8,322	8,485	8,476	8,132	8,291	8,300	8,461
Breakout force	kN	61	61	61	51	51	51	59	59
	lbf	13,712	13,712	13,712	11,464	11,464	11,464	13,263	13,263
Operating weight	kg	3468	3540	3513	3463	6534	6508	6551	6525
	lb	7,643	7,802	7,742	7,632	14,400	14,343	14,438	14,381

*Full compliance to ISO 14397-1 (2007) Sections 1 thru 6, which requires 2% verification between calculation and testing.

Dimensions listed are for a machine configured with general purpose buckets, bolt-on cutting edges, 75 kg (165 lb) operator, no air conditioner and Dunlop 405/70 SPT9 tires.

908M Operating Specifications with Hook On Buckets

		Light Material		Industrial Grapple
		Horizontal Pin	Vertical Pin	Vertical Pin
		Bolt-on Edge	Bolt-on Edge	Bolt-on Edge
Rated capacity	m ³	1.5	1.5	N/A
	yd ³	2.0	2.0	N/A
Width: bucket	mm	2080	2080	2057
	ft/in	6'9"	6'9"	6'8"
Nominal material density, 100% fill factor	kg/m ³	1229	1156	N/A
	lb/yd ³	2,032	1,910	N/A
Clearance: full lift, 45° dump	mm	2463	2346	2439
	ft/in	8'0"	7'8"	8'0"
Reach: full lift, 45° dump	mm	931	1025	865
	ft/in	3'0"	3'4"	2'10"
Reach: level arm, level bucket	mm	2256	2405	2011
	ft/in	7'4"	7'10"	6'7"
Dig depth	mm	101	109	12
	in	4.0	4.3	0.5
Length: overall	mm	5854	6004	5596
	ft/in	19'2"	19'8"	18'4"
Turning radius, bucket at carry	mm	5496	4649	4498
	ft/in	18'0"	15'3"	14'9"
Tipping load – straight, ISO 14397-1*	kg	4527	4256	4422
	lb	9,977	9,380	9,746
Tipping load – full turn, ISO 14397-1*	kg	3688	3467	3602
	lb	8,128	7,641	7,938
Operating weight	kg	6421	6435	6584
	lb	14,151	14,182	14,511

*Full compliance to ISO 14397-1 (2007) Sections 1 thru 6, which requires 2% verification between calculation and testing.

Dimensions listed are for a machine configured with general purpose buckets, bolt-on cutting edges, 75 kg (165 lb) operator, no air conditioner and Dunlop 405/70 SPT9 tires.

Operating Specifications

906M Operating Specifications with Forks

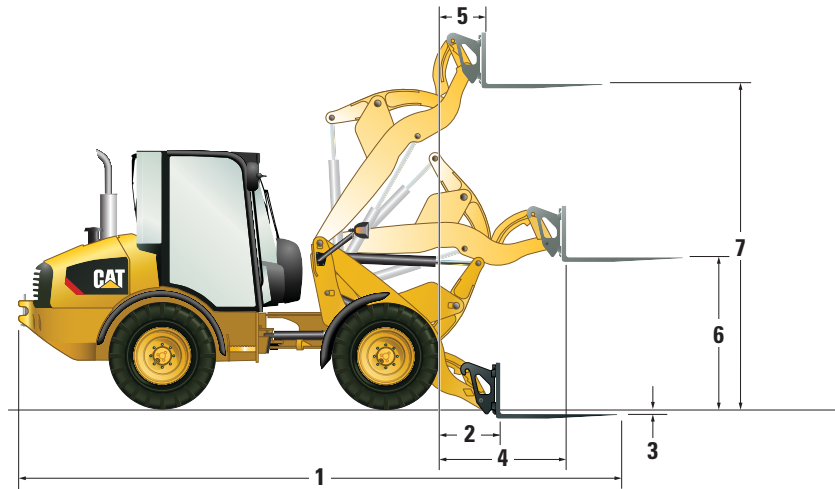

	Horizontal Pin (HPL – ISO)		Vertical Pin		Horizontal Pin (HPL – A)	
Fork carriage width	1400 mm	4'7"	1400 mm	4'7"	1030 mm	3'4"
Tine length – standard	1120 mm	3'8"	1120 mm	3'8"	1220 mm	4'0"
Tine length – optional	1220 mm	4'0"	1220 mm	4'0"		
1 Overall length – standard	5915 mm	19'4"	5943 mm	19'5"	6015 mm	19'8"
Overall length – optional	5915 mm	19'4"	5943 mm	19'5"		
2 Reach at ground level	720 mm	28.3"	749 mm	29.5"	720 mm	28.3"
3 Fork depth below (above) ground	25 mm	1"	(46.5 mm)	(1.8")	25 mm	1"
4 Maximum reach	1215 mm	3'11"	1265 mm	4'1"	1215 mm	3'11"
5 Reach at maximum height	445 mm	1'5"	507 mm	1'7"	445 mm	1'5"
6 Height at maximum reach	1425 mm	4'8"	1492 mm	4'10"	1425 mm	4'8"
7 Maximum height	3090 mm	10'1"	3160 mm	10'4"	3090 mm	10'1"
Tipping load – straight, ISO 14397-1 – standard*	3375 kg	7,438 lb	3237 kg	7,134 lb	3373 kg	7,434 lb
Tipping load – straight, ISO 14397-1 – optional*	3374 kg	7,436 lb	3236 kg	7,132 lb		
Tipping load – full turn, ISO 14397-1 – standard*	2750 kg	6,061 lb	2637 kg	5,811 lb	2748 kg	6,056 lb
Tipping load – full turn, ISO 14397-1 – optional*	2749 kg	6,058 lb	2636 kg	5,809 lb		
Operating weight – standard	5368 kg	11,831 lb	5403 kg	11,908 lb	5369 kg	11,833 lb
Operating weight – optional	5367 kg	11,828 lb	5402 kg	11,906 lb		
Rated load (% of full turn tip):						
50% of tip: SAE J1197 – standard**	1375 kg	3,030 lb	1319 kg	2,905 lb	1374 kg	3,028 lb
50% of tip: SAE J1197 – optional**	1375 kg	3,029 lb	1318 kg	2,904 lb		
60% of tip: rough terrain, EN474-3 – standard**	1650 kg	3,636 lb	1582 kg	3,487 lb	1649 kg	3,633 lb
60% of tip: rough terrain, EN474-3 – optional**	1649 kg	3,635 lb	1582 kg	3,485 lb		
80% of tip: firm and level, EN474-3 – standard**	2200 kg	4,848 lb	2110 kg	4,649 lb	2198 kg	4,845 lb
80% of tip: firm and level, EN474-3 – optional**	2199 kg	4,847 lb	2109 kg	4,647 lb		

*Full compliance to ISO 14397-1 (2007) Sections 1 thru 6, which requires 2% verification between calculation and testing.

**Full compliance to EN474-3 and SAE J1197.

Dimensions listed are for a machine configured with general purpose buckets, bolt-on cutting edges, 75 kg (165 lb) operator, no air conditioner and Dunlop 405/70 SPT9 tires.

907M Operating Specifications with Forks

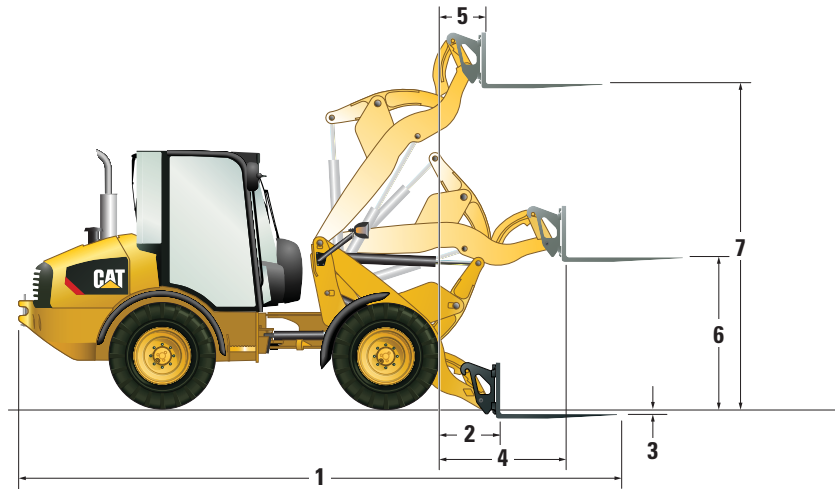

	Horizontal Pin (HPL – ISO)		Vertical Pin		Horizontal Pin (HPL – A)	
Fork carriage width	1400 mm	4'7"	1400 mm	4'7"	1030 mm	3'4"
Tine length – standard	1120 mm	3'8"	1120 mm	3'8"	1220 mm	4'0"
Tine length – optional	1220 mm	4'0"	1220 mm	4'0"		
1 Overall length – standard	5915 mm	19'4"	5943 mm	19'5"	6015 mm	19'8"
Overall length – optional	5915 mm	19'4"	5943 mm	19'5"		
2 Reach at ground level	720 mm	28.3"	749 mm	29.5"	720 mm	28.3"
3 Fork depth below (above) ground	25 mm	1"	(46.5 mm)	(1.8")	25 mm	1"
4 Maximum reach	1215 mm	3'11"	1265 mm	4'1"	1215 mm	3'11"
5 Reach at maximum height	445 mm	1'5"	507 mm	1'7"	445 mm	1'5"
6 Height at maximum reach	1425 mm	4'8"	1492 mm	4'10"	1425 mm	4'8"
7 Maximum height	3090 mm	10'1"	3160 mm	10'4"	3090 mm	10'1"
Tipping load – straight, ISO 14397-1 – standard*	3516 kg	7,749 lb	3374 kg	7,436 lb	3369 kg	7,425 lb
Tipping load – straight, ISO 14397-1 – optional*	3516 kg	7,749 lb	3373 kg	7,434 lb		
Tipping load – full turn, ISO 14397-1 – standard*	2865 kg	6,314 lb	2749 kg	6,058 lb	2745 kg	6,049 lb
Tipping load – full turn, ISO 14397-1 – optional*	2864 kg	6,312 lb	2748 kg	6,056 lb		
Operating weight – standard	5548 kg	12,227 lb	5583 kg	12,304 lb	5587 kg	12,313 lb
Operating weight – optional	5547 kg	12,225 lb	5582 kg	12,302 lb		
Rated load (% of full turn tip):						
50% of tip: SAE J1197 – standard**	1433 kg	3,157 lb	1375 kg	3,029 lb	1373 kg	3,024 lb
50% of tip: SAE J1197 – optional**	1432 kg	3,156 lb	1374 kg	3,028 lb		
60% of tip: rough terrain, EN474-3 – standard**	1719 kg	3,788 lb	1649 kg	3,635 lb	1647 kg	3,629 lb
60% of tip: rough terrain, EN474-3 – optional**	1718 kg	3,787 lb	1649 kg	3,633 lb		
80% of tip: firm and level, EN474-3 – standard**	2292 kg	5,051 lb	2199 kg	4,847 lb	2196 kg	4,839 lb
80% of tip: firm and level, EN474-3 – optional**	2291 kg	5,049 lb	2198 kg	4,845 lb		

*Full compliance to ISO 14397-1 (2007) Sections 1 thru 6, which requires 2% verification between calculation and testing.

**Full compliance to EN474-3 and SAE J1197.

Dimensions listed are for a machine configured with general purpose buckets, bolt-on cutting edges, 75 kg (165 lb) operator, no air conditioner and Dunlop 405/70 SPT9 tires.

Operating Specifications

908M Operating Specifications with Forks

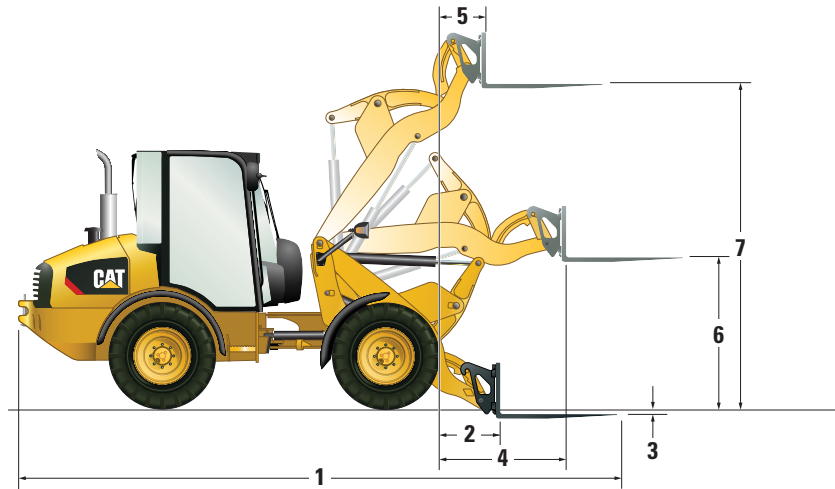

	Horizontal Pin (HPL – ISO)		Vertical Pin		Horizontal Pin (HPL – A)	
Fork carriage width	1400 mm	4'7"	1400 mm	4'7"	1030 mm	3'4"
Tine length – standard	1120 mm	3'8"	1120 mm	3'8"	1220 mm	4'0"
Tine length – optional	1220 mm	4'0"	1220 mm	4'0"		
1 Overall length – standard	6016 mm	19'8"	6150 mm	20'2"	6116 mm	20'0"
Overall length – optional	6116 mm	20'0"	6250 mm	20'6"		
2 Reach at ground level	789 mm	31.1"	923 mm	36.3"	789 mm	31.1"
3 Fork depth below (above) ground	71 mm	2"	(31 mm)	(1.2")	71 mm	2"
4 Maximum reach	1309 mm	4'3"	1444 mm	4'8"	1309 mm	4'3"
5 Reach at maximum height	460 mm	1'6"	594 mm	1'11"	460 mm	1'6"
6 Height at maximum reach	1450 mm	4'9"	1523 mm	4'11"	1450 mm	4'9"
7 Maximum height	3324 mm	10'10"	3302 mm	10'10"	3324 mm	10'10"
Tipping load – straight, ISO 14397-1 – standard*	3871 kg	8,531 lb	3620 kg	7,978 lb	3868 kg	8,525 lb
Tipping load – straight, ISO 14397-1 – optional*	3862 kg	8,511 lb	3611 kg	7,958 lb		
Tipping load – full turn, ISO 14397-1 – standard*	3154 kg	6,951 lb	2949 kg	6,499 lb	3151 kg	6,944 lb
Tipping load – full turn, ISO 14397-1 – optional*	3147 kg	6,935 lb	2942 kg	6,484 lb		
Operating weight – standard	6121 kg	13,490 lb	6148 kg	13,550 lb	6122 kg	13,492 lb
Operating weight – optional	6129 kg	13,508 lb	6156 kg	13,567 lb		
Rated load (% of full turn tip):						
50% of tip: SAE J1197 – standard**	1577 kg	3,475 lb	1475 kg	3,249 lb	1576 kg	3,472 lb
50% of tip: SAE J1197 – optional**	1574 kg	3,467 lb	1471 kg	3,242 lb		
60% of tip: rough terrain, EN474-3 – standard**	1892 kg	4,170 lb	1769 kg	3,899 lb	1891 kg	4,166 lb
60% of tip: rough terrain, EN474-3 – optional**	1888 kg	4,161 lb	1765 kg	3,890 lb		
80% of tip: firm and level, EN474-3 – standard**	2523 kg	5,561 lb	2359 kg	5,199 lb	2521 kg	5,555 lb
80% of tip: firm and level, EN474-3 – optional**	2518 kg	5,548 lb	2354 kg	5,187 lb		

*Full compliance to ISO 14397-1 (2007) Sections 1 thru 6, which requires 2% verification between calculation and testing.

**Full compliance to EN474-3 and SAE J1197.

Dimensions listed are for a machine configured with general purpose buckets, bolt-on cutting edges, 75 kg (165 lb) operator, no air conditioner and Dunlop 405/70 SPT9 tires.

Operating Specifications with Material Handling Arm

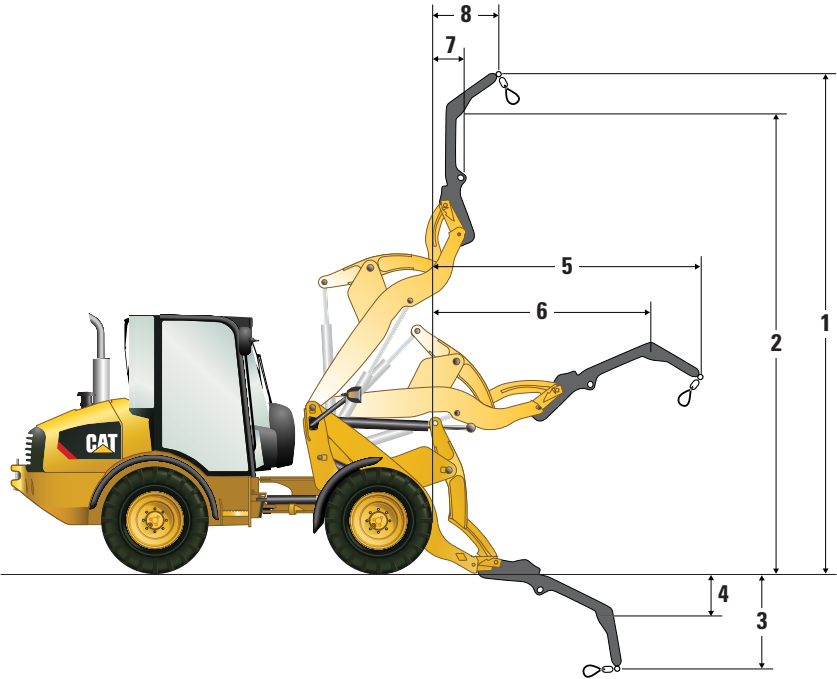

	906M		907M		908M	
1	4508 mm	14'9"	4508 mm	14'9"	4669 mm	15'3"
2	4080 mm	13'4"	4080 mm	13'4"	4241 mm	13'10"
3	1460 mm	4'9"	1460 mm	4'9"	1457 mm	4'9"
4	988 mm	3'2"	988 mm	3'2"	990 mm	3'2"
5	3296 mm	10'9"	3296 mm	10'9"	3415 mm	11'2"
6	2856 mm	9'4"	2856 mm	9'4"	2976 mm	9'9"
7	694 mm	2'3"	694 mm	2'3"	735 mm	2'4"
8	981 mm	3'2"	981 mm	3'2"	1023 mm	3'4"
Mass	131 kg	288 lb	131 kg	288 lb	131 kg	288 lb
Rated load (50% of full turn tip, SAE J1197):*						
Lift point 1	1067 kg	2,350 lb	1111 kg	2,448 lb	1259 kg	2,773 lb
Lift point 2	928 kg	2,045 lb	967 kg	2,131 lb	1101 kg	2,426 lb

*Full compliance to EN474-3 and SAE J1197.

Dimensions listed are for a machine configured with general purpose buckets, bolt-on cutting edges, 75 kg (165 lb) operator, no air conditioner and Dunlop 405/70 SPT9 tires.

906M, 907M, 908M Standard and Optional Equipment

Standard and Optional Equipment

Standard and Optional equipment may vary. Consult your Cat dealer for details.

Model	906M		907M		908M	
	Std.	Opt.	Std.	Opt.	Std.	Opt.
TRANSMISSION AND HYDRAULICS						
• 100% differential lock on both axles, selectable on the move	✓	-	✓	-	✓	-
• 18° frame oscillation, 78° articulation	✓	-	✓	-	✓	-
• Adjustable speed control (creeper control)	-	✓	-	✓	-	✓
• Adjustable high stat response settings	-	✓	-	✓	-	✓
• Connect under pressure hydraulic quick connector	-	-	-	-	-	-
• Demand based cooling fan	✓	-	✓	-	✓	-
• Electronic throttle lock	-	✓	-	✓	-	✓
• Hydrostatic drive	✓	-	✓	-	✓	-
• Loader arm float function	✓	-	✓	-	✓	-
• Parallel lift Z-bar loader	✓	-	✓	-	✓	-
• Proportional auxiliary hydraulic circuit	✓	-	✓	-	✓	-
• Ride control	-	✓	-	✓	-	✓
• Rimpull control	-	✓	-	✓	-	✓
• Speeder, 35 km/h (21.7 mph) with secondary steering	-	✓	-	✓	-	✓
• Transmission, 20 km/h (12.4 mph) with heavy duty axles	✓	-	✓	-	✓	-
• Transmission inching function	✓	-	✓	-	✓	-
ENGINE						
• Cat C3.3B DIT Tier 4 Final/ EU Stage IIIB or Tier 4 Interim/ Stage IIIA engine	✓	-	✓	-	✓	-
• Cat extended life coolant	✓	-	✓	-	✓	-
• Closed circuit breather	✓	-	✓	-	✓	-
• Easy quick release fuel filter/ water separator	✓	-	✓	-	✓	-
• ECO mode	✓	-	✓	-	✓	-
• Engine block heater 120V	-	✓	-	✓	-	✓
• Engine oil drain valve (non-spill ECO drain)	✓	-	✓	-	✓	-
• Lockable engine compartments	✓	-	✓	-	✓	-
• Precleaner for engine air filter	-	✓	-	✓	-	✓
• Two stage air cleaner with visual indicator	✓	-	✓	-	✓	-

Model	906M		907M		908M	
	Std.	Opt.	Std.	Opt.	Std.	Opt.
ELECTRICAL						
• Alternator 90 amp	✓	-	✓	-	✓	-
• Battery disconnect switch	✓	-	✓	-	✓	-
• Cab mounted fuse panel	✓	-	✓	-	✓	-
• Engine cold starter aid	✓	-	✓	-	✓	-
• Heavy duty battery, 12V	✓	-	✓	-	✓	-
• Machine Security System (MSS)	-	✓	-	✓	-	✓
• Magnetic rotating beacon	-	✓	-	✓	-	✓
• Service point connector for electronic diagnosis (Cat Electronic Technician™)	✓	-	✓	-	✓	-
• Reversing alarm	✓	-	✓	-	✓	-
• Working lights, two front and two rear	-	✓	-	✓	-	✓
• Work tool wiring harness	-	✓	-	✓	-	✓
GENERAL						
• Custom color	-	✓	-	✓	-	✓
• E-coat paint primer	✓	-	✓	-	✓	-
• Pressure test points	✓	-	✓	-	✓	-
• Rear light guards	-	✓	-	✓	-	✓
• Recovery hitch and pin	✓	-	✓	-	✓	-
• Scheduled Oil Sampling S·O·S SM ports	✓	-	✓	-	✓	-
• Tire options including heavy duty tires	-	✓	-	✓	-	✓
FLUIDS						
• Cat extended life coolant (-50° C/-58° F)	-	✓	-	✓	-	✓
LOADER						
• Adjustable implement modulation	-	✓	-	✓	-	✓
• High flow auxiliary hydraulics with pressure relieving quick disconnect manifold	-	✓	-	✓	-	✓
• Load check valves	-	✓	-	✓	-	✓
• Return To Dig tool positioner	-	✓	-	✓	-	✓
WORK TOOLS						
• For all work tool options, consult your local Cat dealer	-	-	-	-	-	-

906M, 907M, 908M Standard and Optional Equipment

Standard and Optional Equipment

Standard and Optional equipment may vary. Consult your Cat dealer for details.

Model	906M		907M		908M	
	Std.	Opt.	Std.	Opt.	Std.	Opt.
OPERATOR ENVIRONMENT						
• Adjustable internal mirror	✓	-	✓	-	✓	-
• Adjustable wrist rest	✓	-	✓	-	✓	-
• Air conditioning	-	✓	-	✓	-	✓
• Auxiliary power sockets	✓	-	✓	-	✓	-
• Cabin light	-	✓	-	✓	-	✓
• Cat Radio/CD/MP3/WMA/AUX	-	✓	-	✓	-	✓
• Comfort cab includes: cloth suspension seat, heated rear window, sliding left window and radio ready)	-	✓	-	✓	-	✓
• Coat hook	✓	-	✓	-	✓	-
• Cup holder	✓	-	✓	-	✓	-
• Deluxe cab includes: Comfort cab options plus heated cloth air suspension seat with lumbar support and right sliding window	-	✓	-	✓	-	✓
• Digital service hour meter	✓	-	✓	-	✓	-
• Easy clean cab floor	✓	-	✓	-	✓	-
• Gauges: fuel hydraulic temperature, coolant temperature, speedometer	✓	-	✓	-	✓	-
• Heated rear window (enclosed cab)	-	✓	-	✓	-	✓
• Heater with window side and feet vents (enclosed cab)	-	✓	-	✓	-	✓
• Multifunction joystick with direction control	✓	-	✓	-	✓	-

Model	906M		907M		908M	
	Std.	Opt.	Std.	Opt.	Std.	Opt.
OPERATOR ENVIRONMENT (continued)						
• On board digital display cluster	✓	-	✓	-	✓	-
• Operator station on isolation mounts	✓	-	✓	-	✓	-
• Radio ready kit including speakers (enclosed cab)	-	✓	-	✓	-	✓
• Rear blind	-	✓	-	✓	-	✓
• Retractable seat belt	✓	-	✓	-	✓	-
• ROPS and FOPS certified canopy/cab	✓	-	✓	-	✓	-
• Sound suppression	✓	-	✓	-	✓	-
• Sun visor	✓	-	✓	-	✓	-
• Suspended brake/accelerator pedals	✓	-	✓	-	✓	-
• Suspension seat	✓	-	✓	-	✓	-
• Two doors (enclosed cab)	-	✓	-	✓	-	✓
• Two external knock back mirrors	✓	-	✓	-	✓	-
• Warning indicators for major systems	✓	-	✓	-	✓	-
• Wiper/washer front and rear (enclosed cab)	-	✓	-	✓	-	✓
• Warnings: master, park brake, hydraulic oil pressure, engine oil pressure, coolant temp, electrical system, hydraulic filter bypass	✓	-	✓	-	✓	-

For more complete information on Cat products, dealer services, and industry solutions, visit us on the web at www.cat.com

AEHQ7734-01 (03-2016)
Replaces AEHQ7734

© 2016 Caterpillar
All rights reserved

Materials and specifications are subject to change without notice. Featured machines in photos may include additional equipment. See your Cat dealer for available options.

CAT, CATERPILLAR, SAFETY.CAT.COM, their respective logos, "Caterpillar Yellow" and the "Power Edge" trade dress, as well as corporate and product identity used herein, are trademarks of Caterpillar and may not be used without permission.



Courtesy of Machine.Market