

924Hz

Wheel Loader

CATERPILLAR®



Cat® C6.6 Engine with ACERT™ Technology

Net power (SAE J1349) 96 kW 128 hp

EPA Tier 3, EU Stage III Compliant

Weight

Operating Weight 10 968 kg 24,180 lb

Buckets

Bucket Capacity 1.7-2.1 m³ 2.2-2.7 yd³

Courtesy of Machine.Market

924Hz Features

High Performance Power Train

Clean, quiet operation with superior power.

Powerful Hydraulic System

System senses work demand and adjusts flow and pressure to match for precise, efficient control.

Loader Linkage

Proven design delivers outstanding bucket loading performance.

Comfortable Cab

Large, spacious cab and low-effort, ergonomic joystick controls let you concentrate on your work.

Buckets

Caterpillar® buckets deliver superior digging, loading and carrying performance.



Contents

Power Train	3
Hydraulic System	4
Loader Linkage	4
Operator Station	5
Buckets.....	6
Serviceability.....	7
Customer Support.....	7
Specifications	8
Standard and Optional Equipment.....	14

The Cat® 924Hz Wheel Loader leads the industry in operator comfort and performance. Size, power, and performance make this machine ideal for a wide range of jobs. Fast cycle times help you move more material. Large spacious cab with joystick control keeps you comfortable throughout the work day, allowing you to get more done. Loader design delivers strength and durability with superior control. Discover how much more you can get done with the new 924Hz.



Power Train

Delivers maximum rimpull to the ground and full power to loader hydraulics.

Cat Engine

The Cat® C6.6 engine provides cleaner, quieter operation while delivering superior performance and durability. The 96 kW (128 hp) rated net power engine meets all worldwide emissions standards and features flatter power curve for outstanding response in the working RPM range (1,900 to 2,300), noise reduction technologies for up to 5 dB reduction, and patented ACERT™ Technology combined with common rail fuel system, smart waste gate turbocharger and crossflow head design for reduced emissions.

Cat Axles

Heavy-duty axles feature hardened gears and bearings for durable performance. Rear axle oscillates up to 12 degrees to help assure four-wheel ground contact for optimum traction and stability. Optional Limited Slip Differential enables outstanding traction in poor underfoot conditions.

Cat Transmission

Rugged Cat transmission uses heavy-duty components for durable and reliable operation. The operator can choose between manual shift and two autoshift modes, Performance or Economy. Performance mode provides maximum acceleration while the economy mode increases fuel economy and improves operator comfort.

Hydraulics

System provides high efficiency with low effort, precise control.



Proven Design

Time tested hydraulic system provides low effort operation and superior control. Fast loader cycle times help you get more done.

Dual Hydraulic Pumps System

Load-sensing steering pump provides outstanding response during heavy and light duty operations.

Load sensing implement hydraulics provide exceptional second gear hydraulic-to-rimpull match for better material handling.

Ride Control System

The optional Ride Control System provides a comfortable ride and excellent material retention.

Nitrogen charged accumulator enables optimum cushioning over uneven terrain for all loads and speeds.

The system operates in Automatic – as the loader ground speed exceeds 5 km/h (3 mph) the system will activate, below 5 km/h (3 mph) the system is off providing maximum lift power.

Loader Linkage

Strong design delivers superior performance.

Z-Bar Design

Z-bar linkage generates excellent breakout force and ample rack back angle for better bucket loading and load retention.

Lift arms are solid steel, providing superior strength with an excellent front end viewing area. The proven design offers excellent dump clearance and reach for exceptional truck loading performance.





Operator Station

Superior comfort keeps you productive, all day long.

Experience comfort and convenience in the H-Series cab. The spacious interior and ergonomic controls keep you comfortable throughout the work day. Choose the seat that meets your needs – the standard, fully adjustable seat or the optional Cat Contour seat for added adjustment and air suspension. The two-door design lets you enter and exit from either side of the machine and wide, serrated steps provide stable footing. Both doors lock open 180 degrees and feature sliding glass windows for better communication with workers on the ground. Large flat glass windows provide excellent visibility all around the machine. The rear window features a standard electric defroster.

Controls

Low effort, ergonomic joystick controls provide easy operation of lift and tilt functions. The standard joystick features an integrated directional control switch for added convenience. The operator programmable transmission neutralizer can be set in seconds optimizing brake effort for all applications.

Instrument Panel

The sealed instrument panel with easy to read white faced gauges and indicators keeps the operator informed of system conditions. The large LED readout provides ground speed and other critical information.

Optional Rear View Camera

This work area visual enhancement system uses a closed circuit video monitoring system. Up to three cameras can be mounted on the machine frame. Objects can be viewed on a color LCD monitor in the cab.

Buckets

Cat[®] Buckets are built for high performance.

The Right Bucket for the Job

Caterpillar offers a variety of buckets to meet your specific job requirements. Careful match of the bucket design and machine operating characteristics provide the best digging, loading and carrying performance.

General Purpose Buckets

Caterpillar[®] general purpose buckets, available in 1.8 m³ (2.4 yd³) and 2.1 m³ (2.7 yd³) capacities with bolt-on cutting edge, are suitable for most general applications. Features include:

- Improved bucket design with longer floor and a larger radius for easier flow of material into the bucket.
- Patented Two-Bolt Corner Guard Cutting Edge System for superior wear resistance, better stability and a simple bolt-on system.
- Built-in, replaceable heel wear plates for extended bucket life.

Ground Engaging Tools

Ground engaging tools include hardened steel cutting edges, choice of short or long teeth and a variety of tooth adapters. These tools optimize performance, improve load retention and extend the useful life of Caterpillar buckets.

Versatility

For expanded machine versatility, factory installed quick couplers and other special purpose buckets are also available. Contact your Caterpillar dealer for details.



Serviceability

Easy access and minimal maintenance requirements keep your machine on the job.



Convenient service features make maintenance easy.

All service points are accessible from ground level on the right side of the engine. Gull-wing doors with gas struts lift for exceptional access to filters and service points. Extended service intervals reduce service time and increase machine availability.

- Sight gauges let you easily check radiator coolant, hydraulic oil and transmission oil levels as well as engine air filter restriction without opening the air cleaner.
- Standard pressure taps allow quick diagnosis of the entire hydraulic system.
- S•O•SSM ports make oil sampling quicker, cleaner and provide the best oil sample for analysis.
- Spin-on filters for engine oil, transmission oil and hydraulic oil are vertically mounted for easier servicing.
- 924Hz features a standard electronic fuel prime pump.
- Sequentially placed radiator and oil coolers are easy to access.
- Swing-out cooling fan allows quick and easy cleaning and servicing of the radiator. The fan is hydraulically driven and separate from the engine compartment for low noise operation.
- Optional reversing fan cleans screens without interrupting machine operation.

Customer Support

Unmatched support makes the difference

Your Cat dealer is ready to assist you with your purchase decision and everything after.

- Make comparisons of machines, with estimates of component life, preventative maintenance and cost of production.
- Financing packages are flexible to meet your needs.
- Your Cat dealer can evaluate the cost to repair, rebuild and replace your machine, so you can make the right choice.
- For more information on Cat products, dealer services and industry solutions, visit us at www.cat.com.



924Hz Wheel Loader Specifications

Engine		
Rated net power @ 2,300 rpm	96 kW	128 hp
Model	Cat® C6.6	
SAE J1349	96 kW	128 hp
ISO 9249 (1997)	97 kW	130 hp
EEC 80/1269	97 kW	130 hp
Max. net power @ 1,800 rpm	103 kW	138 hp
SAE J1349	103 kW	138 hp
ISO 9249 (1997)	104 kW	139 hp
EEC 80/1269	104 kW	139 hp
Bore	105 mm	4.13 in
Stroke	127 mm	5 in
Displacement	6.6 L	403 in ³
Net torque	653 N·m	482 ft-lb
Peak torque	673 N·m	496 ft-lb

- Net Power ratings are tested at the reference conditions for the specified standard.
- Net power shown is the power available at the flywheel when the engine is equipped with alternator, air cleaner, muffler and fan at minimum speed.
- No derating required up to 3000 m (9,843 ft) altitude. Auto derate protects hydraulic and transmission systems.
- When the fan is at maximum speed, Rated Net Power is 82 kW (109 hp) and Maximum Net Power is 92 kW (123 hp) at the flywheel per the SAE reference conditions.
- The Caterpillar® C6.6 engine meets Tier 3 off-highway emission regulations.

Engine Torque

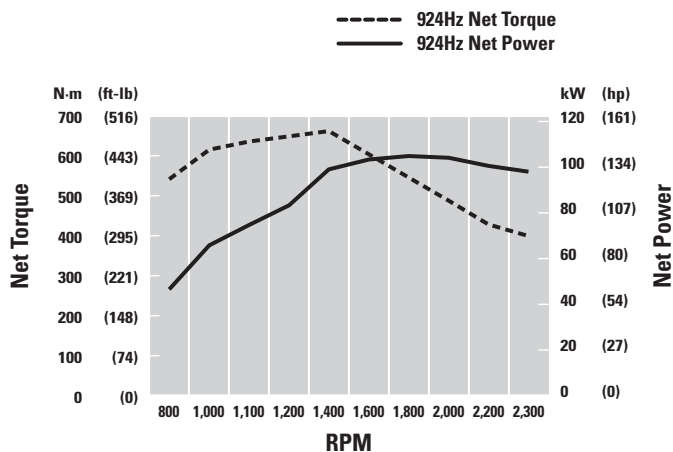

Buckets		
Bucket capacities	1.7 m ³ - 2.1 m ³	2.2 yd ³ - 2.7 yd ³

Weights		
Operating weight	10 968 kg	24,180 lb
• Specifications shown are for the 924Hz with optional counterweight, standard lubricants, full fuel tank, deluxe cab, Limited Slip rear axle with heavy duty brakes, additional guarding, 1.8 m ³ (2.3 yd ³) bucket with bolt-on cutting edge, 80 kg (176 lb) operator and 20.5 R25 radial (L-3) XHA tires.		

Steering		
Steering articulation	40°	40°
Minimum turning radius (over tire)	5070 mm	200 in
Steering angle, each direction	40°	40°
Steering cylinders, two, bore	70 mm	2.75 in
Hydraulic output at 2,300 engine rpm and 6900 kPa (1,000 psi)	104 L/min	27 gal/min
Maximum working pressure	20 685 kPa	3,000 psi

Loader Hydraulic System		
Output at 2,300 engine rpm and 6900 kPa (1,000 psi) with SAE 10W oil at 65° C (150° F)	152 L/min	39.5 gal/min
Pump flow – implement pump	152 L/min	40.15 gal/min
Relief pressure – implement pump	258.9 bar	3,755 psi
Maximum working pressure	25 900 kPa	3,755 psi
Hydraulic cycle time	9 Seconds	
Raise	5.2 Seconds	
Dump	1.1 Seconds	
Lower, empty, float down	2.7 Seconds	
Total	9 Seconds	
Lift cylinders, double acting:		
Bore	107.95 mm	4.25 in
Stroke	755 mm	29.7 in
Tilt cylinder, double acting:		
Bore	120.6 mm	4.75 in
Stroke	520 mm	20.5 in

Service Refill Capacities		
Fuel tank	225 L	59.4 gal
Cooling system	32 L	8.5 gal
Crankcase	16.5 L	4.4 gal
Transmission	23 L	6.1 gal
Differentials and final drives:		
Front	21 L	5.5 gal
Rear	21 L	5.5 gal
Hydraulic system (including tank)	125 L	33 gal
Hydraulic tank	70 L	18.5 gal

Transmission

Standard transmission		38.5 km/h	23.9 mph
max travel speeds			
Forward	1	6.7 km/h	4.2 mph
	2	12.2 km/h	7.6 mph
	3	21.8 km/h	13.5 mph
	4	38.5 km/h	23.9 mph
Reverse	1	6.7 km/h	4.2 mph
	2	12.2 km/h	7.6 mph
	3	21.8 km/h	13.5 mph
Optional low speed transmission max travel speeds			
Forward	1	3.7 km/h	2.3 mph
	2	7.5 km/h	4.7 mph
	3	19.6 km/h	12.2 mph
	4	39 km/h	24.2 mph
Reverse	1	4.1 km/h	2.5 mph
	2	8.1 km/h	5 mph
	3	21.2 km/h	13.2 mph

Tires

Size	20.5 R25 Radial (L-3)	
Tread width	1880 mm	6 ft 3 in

- Choice of:
 - 17.5-25, 12PR (L-2)
 - 17.5-25, 12PR (L-3)
 - 17.5 R25, radial (L-2)
 - 17.5 R25, radial (L-3)
 - 500/65 R25, radial (L-2)
 - 500/65 R25, radial (L-3)
 - 20.5-25, 12PR (L-2)
 - 20.5-25, 12PR (L-3)
 - 20.5 R25, radial (L-2)
 - 20.5 R25, radial (L-3)
- Other tire choices are available, contact your Cat® Dealer for details.
- In certain applications, the loader's productive capabilities may exceed the tire's tonnes-km/h (ton-mph) capabilities. Caterpillar recommends that you consult a tire supplier to evaluate all conditions before selecting a tire model.

Cab

ROPS	SAE J1040 MAY94, ISO 3471-1994	
FOPS	SAE J231 JAN81, ISO 3449-1992 Level II	

- Caterpillar cab and Rollover Protective Structure (ROPS) are standard in North America and Europe.
- When properly installed and maintained, the cab offered by Caterpillar, when tested with doors and windows closed as per work cycle procedures specified in ANSI/SAE J1166 May 90, results in operator sound exposure Leq (equivalent sound pressure level) of 74 dB(A).

Operating Specifications

Static tipping load (full turn)	7640 kg	16,844 lb
Reach – full lift/45 degree dump angle	791 mm	2 ft 7 in
Dump clearance – full lift/45 degree dump angle	2828 mm	9 ft 3 in
Articulation angle	40°	40°

924Hz Wheel Loader Specifications

Dimensions

All dimensions are approximate. Dimensions may vary with bucket. Refer to Operating Specifications.

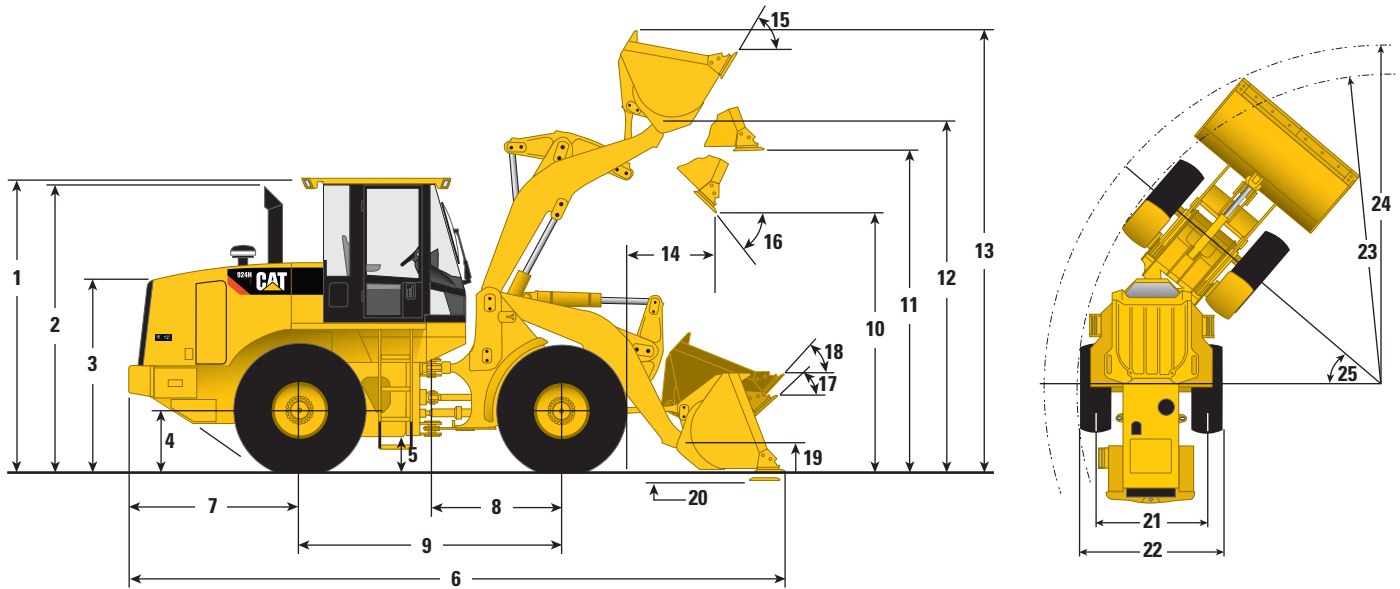

1	Height to top of ROPS/FOPS	3227 mm	(10 ft 7 in)
2	Height to top of exhaust stack	3211 mm	(10 ft 6 in)
3	Height to top of hood	2219 mm	(7 ft 3 in)
4	Height to center of axle	692 mm	(2 ft 3 in)
5	Ground clearance	436 mm	(1 ft 5 in)
6	Overall length	6898 mm	(22 ft 8 in)
7	Length – rear axle to bumper	1962 mm	(6 ft 5 in)
8	Center line of front axle to hitch	1400 mm	(4 ft 7 in)
9	Wheel base length	2800 mm	(9 ft 2 in)
10	Dump clearance at maximum lift and 45° dump	2828 mm	(9 ft 3 in)
11	Bucket clearance at maximum lift and level	3432 mm	(11 ft 3 in)
12	Bucket pin height at maximum lift	3757 mm	(12 ft 4 in)
13	Overall height – bucket raised	4809 mm	(15 ft 9 in)
14	Reach at maximum lift and 45° dump	791 mm	(2 ft 7 in)
15	Rack back angle at maximum lift		58°
16	Dump angle at maximum lift		45°
17	Rack back angle at ground		44°
18	Rack back angle at carry		48°
19	Carry height	435 mm	(1 ft 5 in)
20	Digging depth	42 mm	(2 in)

Dimensions listed are for 924Hz with 1.8 m³ (2.3 yd³) pin-on bucket with bolt-on cutting edge, cab with A/C, optional counterweights, limited slip axles, heavy duty rear brakes, additional guarding, sound suppression, work tool, 80 kg (176 lb) operator and Michelin 20.5 R25 L3 XHA tires.

	20.5 R25 (L-3) XHA Tires		17.5-25 12PR (L-2) Tires	
21	Width at tread center	1880 mm (6 ft 2 in)	1880 mm (6 ft 2 in)	
22	Overall width over tires	2492 mm (8 ft 2 in)	2356 mm (7 ft 9 in)	
23	Minimum turning radius over tires	5104 mm (16 ft 9 in)	5070 mm (16 ft 8 in)	
24	Minimum turning radius over bucket at ground level	5598 mm (18 ft 4 in)	5614 mm (18 ft 5 in)	
25	Steering angle – left/right	40°	40°	
	Change in vertical dimension	no change	no change	-44 mm (-2 in)

Operating Specifications

		Pin-on Buckets					
		With Bolt-On Cutting Edge		With Bolt-On Teeth & Segments*		With Bolt-On Teeth*	
Rated bucket capacity (§)	m ³	1.8	2.1	1.8	2.1	1.7	2.0
	yd ³	2.4	2.7	2.4	2.7	2.2	2.6
Struck capacity (§)	m ³	1.5	1.7	1.5	1.7	1.4	1.6
	yd ³	2.0	2.2	2.0	2.2	1.8	2.1
Bucket width	mm	2550	2550	2620	2620	2620	2620
	ft/in	8'4"	8'4"	8'7"	8'7"	8'7"	8'7"
10 Dump clearance at full lift and 45° discharge (§)	mm	2826	2757	2722	2653	2722	2653
	ft/in	9'3"	9'1"	8'11"	8'8"	8'11"	8'8"
14 Reach at full lift and 45° discharge (§)	mm	791	859	894	962	894	962
	ft/in	2'7"	2'10"	2'11"	3'2"	2'11"	3'2"
Reach at 45° discharge and 2130 mm (7'0") clearance (§)	mm	1318	1350	1365	1392	1365	1392
	ft/in	4'4"	4'5"	4'6"	4'7"	4'6"	4'7"
Reach with lift arms horizontal and bucket level	mm	2059	2156	2205	2302	2205	2302
	ft/in	6'9"	7'1"	7'3"	7'7"	7'3"	7'7"
20 Digging depth (§)	mm	43	51	56	64	56	64
	in	1.7"	2.0"	2.2"	2.5"	2.2"	2.5"
6 Overall length	mm	6898	7001	7044	7147	7023	7127
	ft/in	22'8"	23'0"	23'1"	23'5"	23'1"	23'5"
13 Overall height with bucket at full raise (§)	mm	4809	4936	4809	4936	4809	4936
	ft/in	15'9"	16'2"	15'9"	16'2"	15'9"	16'2"
24 Loader clearance radius with bucket in carry position (§)	mm	5616	5646	5692	5722	5689	5719
	ft/in	18'5"	18'6"	18'8"	18'9"	18'8"	18'9"
Static tipping load straight (§)	kg	8816	8732	8653	8565	8757	8671
	lb	19,437	19,251	19,077	18,884	19,306	19,117
Static tipping load full 40° turn (§)	kg	7640	7560	7477	7393	7581	7499
	lb	16,844	16,667	16,484	16,299	16,713	16,533
Breakout force (§)	kg	9954	8975	9833	8854	10,734	9604
	lb	21,945	19,787	21,678	19,520	23,665	21,173
Operating weight	kg	10,968	11,021	11,104	11,156	11,018	11,071
	lb	24,180	24,297	24,480	24,595	24,291	24,408

Specifications shown are for 924Hz with cab with A/C, optional counterweight, limited slip axles, heavy duty rear brakes, additional guarding, sound suppression, work tool, 80 kg (176 lb) operator and Michelin 20.5 R25 L3 XHA tires.

* Dimensions are measured to the tip of the bucket teeth to provide accurate clearance data. SAE standards specifies the cutting edge.

(§) Specifications and ratings conform to all applicable standards recommended by the Society of Automotive Engineers (SAE), including SAE-Standards J732 JUN92 and J742 FEB85 governing ratings.

Other Ground Engaging Tools available, consult your Cat dealer.

924Hz Wheel Loader Specifications

Supplemental Specifications

	Change in Operating Weight		Change in Articulated Static Tipping Load with Pin-On Bucket 1.8 m ³ (2.3 yd ³)	
	kg	lb	kg	lb
Canopy, ROPS (less cab)	-199	-438	-182	-400
No optional counterweights	-320	-704	-609	-1,340
Without guard, crankcase	-15	-33	-21	-46
Without guard, driveshaft	-43	-95	-5	-11
Without guard, power train	-52	-114	-51	-112
Without ride control system	-40	-88	-29	-64
Without secondary steering	-37	-81	-33	-73
Tires, 1-piece rims				
17.5-25, 12PR (L-2)	-652	-1,434	-408	-898
17.5-25, 12PR (L-3)	-580	-1,276	-363	-799
17.5-25, radial (L-2)	-612	-1,346	-383	-843
17.5-25, radial (L-3)	-512	-1,126	-320	-704
Tires, 3-piece rims				
17.5-25, 12PR (L-2)	-528	-1,162	-330	-726
17.5-25, 12PR (L-3)	-456	-1,003	-285	-627
17.5-25, radial (L-2)	-488	-1,074	-305	-671
17.5-25, radial (L-3)	-388	-854	-243	-535
500/65 R25, radial (L-2)	-196	-431	-123	-271
500/65 R25, radial (L-3)	-136	-299	-85	-187
20.5-25, 12PR (L-2)	-240	-528	-150	-330
20.5-25, 12PR (L-3)	-36	-79	-22	-48
20.5-25, radial (L-2)	-172	-378	-108	-238
20.5-25, radial (L-3)	0	0	0	0

Typical Material Densities – Loose

	kg/m ³	lb/yd ³		kg/m ³	lb/yd ³
Basalt	1960	3,305	Gypsum		
Bauxite, Kaolin	1420	2,394	broken	1810	3,052
Clay			crushed	1600	2,698
natural bed	1660	2,799	Limestone		
dry	1480	2,495	broken	1540	2,596
wet	1660	2,799	crushed	1540	2,596
Clay and gravel			Sand		
dry	1420	2,394	dry, loose	1420	2,394
wet	1540	2,596	damp	1690	2,849
Decomposed rock			wet	1840	3,102
75% rock, 25% earth	1960	3,305	Sand and clay		
50% rock, 50% earth	1720	2,900	loose	1600	2,698
25% rock, 75% earth	1570	2,647	Sand and gravel		
Earth			dry	1720	2,900
dry, packed	1510	2,546	wet	2020	3,416
wet, excavated	1600	2,698	Sandstone	1510	2,546
Granite			Shale	1250	2,107
broken	1660	2,799	Slag		
Gravel			broken	1750	2,950
pitrun	1930	3,254	Stone		
dry	1510	2,546	crushed	1600	2,698
dry, 6-50 mm (0.2-2")	1690	2,849			
wet, 6-50 mm (0.2-2")	2020	3,406			

Bucket Selection – Pin-on Buckets

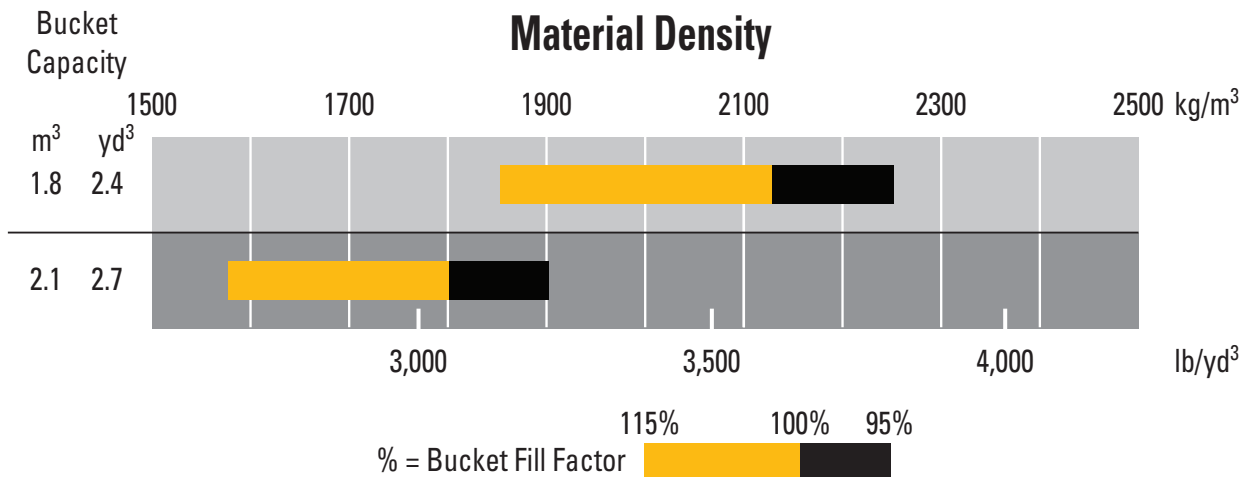

924Hz Standard Equipment

Standard equipment may vary. Consult your Caterpillar dealer for details.

ELECTRICAL

Alternator, 95-amp brushless
Alarm, back-up
Batteries, maintenance-free, 950 CCA, (2)
Directional signals (front & rear)
Starting and charging system, 24V
Halogen work lights (front & rear)
Ignition key start/stop switch
Roading lights
Starting aid, thermal
Switch, battery disconnect

OPERATOR ENVIRONMENT

Standard two door cab includes all of the following items:

Sun visor
Radio ready kit
External mirrors
12 volt electrical outlet
Work lights, four cab-mounted (two front, two rear)
Sealed Instrument Gauge:

- Engine RPM
- Hydraulic oil temperature
- Engine coolant temperature
- Torque converter oil temperature
- Fuel level
- Digital LED speedometer, hour meter/odometer

Indicator Lights:

- Turn signal
- Primary steering malfunction
- Hydraulic oil bypass
- Parking brake applied
- Brake charge pressure low
- Transmission oil temperature
- General warning
- Electrical system voltage low
- Fuel water separator
- Engine oil temperature
- Bright lights activated

Adjustable tilt steering column
Coat hook

Ground level door release
Horn, steering wheel mounted (electric)
Hydraulic control lever lockout
Interior light
Lighter
Lunch box storage with cup holder
Pilot hydraulic implement controls
Rear window defroster, electric
Rear view mirrors (2 inside)
Seat, adjustable suspension, armrest (fabric or vinyl)
Seat belt, 75 mm (3 in), retractable
Tinted safety glass, front
Tool box
Wet arm wiper/washer (front & rear), front intermittent

POWER TRAIN

Engine, Cat C6.6 ACERT

- Low emission diesel engine
- Noise reduction technology
- Smart waste gate turbocharged
- Aftercooled
- Closed Circuit Breather
- Electronically controlled

Air cleaner, dry type
Axle seal guards, integrated
Brakes, enclosed wet-disc full hydraulic
Differentials, conventional front and rear
Driveshaft, lubed for life
Electric fuel prime pump
Engine speed control
Fuel/water separator
Muffler
Radiator, unit serviceable
S•O•S oil sampling port, engine oil
S•O•S oil sampling port, transmission oil
Torque converter
Transmission, 4F/3R, autoshift, single lever control with F/N/R and kickdown button
Transmission neutralizer; operator programmable

HYDRAULICS

Hydraulic diagnostic connectors
Heavy duty hydraulic oil cooler
Hydraulic control, 2-valve, 1-lever with F/N/R
Load-sensing steering system
S•O•SSM oil sampling port, hydraulic oil

OTHER STANDARD EQUIPMENT

Antifreeze/coolant, extended-life protects to -36° C (-33° F)
Automatic bucket positioner/fork positioner
Brakes, secondary and parking
Counterweight
Engine enclosure, lockable
Fenders, front
Hitch, recovery
Loader linkage, z-bar
Lift kickout, automatic
Machine Security System ready
Product Link ready
Remote grease lines
Steering stops, cushioned
Swing-out, hydraulically driven demand fan
Vandalism protection, lockable service points
Visual indicators:

- air cleaner service
- coolant level
- hydraulic oil
- transmission oil

Optional equipment may vary. Consult your Caterpillar dealer for details.

Antifreeze/coolant, extended-life, protects to
-50° C (-58° F)

Axles:

- Rear Limited Slip Differential
- Rear Limited Slip Differential, with heavy duty brakes (axle oil cooler included)

Beacon light, rotating or strobe,
magnetic-mount

Buckets/ground engaging tools

Canopy, ROPS

Counterweight, additional, optional

Deluxe Cab arrangement includes:

- Sun visor
- Rear sunscreen
- Radio ready kit
- External heated mirrors
- Work lights, six cab-mounted
(four front, two rear)

Fan, reversing

Fenders, roading, rear

Fenders, steel

Guards:

- Crankcase
- Driveshaft, front
- Power train
- Lights
- Windshield
- Radiator

Hydraulic control auxiliary, third valve

Load check valves (dealer installed)

Machine Security System

Material handling arm

Pallet forks, carriage

Quick Coupler

Radiator, wide fin spacing, 5.5 fpi

Radio packages:

- Radio, AM/FM
- Radio, AM/FM with CD player

Rear-view camera system

Ride Control System

Seat, Cat Contour, fabric, electrically
adjustable with air suspension

Sound suppression package, available in
select markets

Starting aid, engine coolant heater, 120V

Starting aid, ether

Steering, secondary

Tires:

- Bias ply, 17.5-25 and 20.5-25
- Radial, 17.5-R25 and 20.5-R25

924Hz Wheel Loader

For more complete information on Cat products, dealer services, and industry solutions, visit us on the web at www.cat.com

© 2007 Caterpillar Inc.
All rights reserved
Printed in the U.S.A.

Materials and specifications are subject to change without notice. Featured machines may include additional equipment. See your Caterpillar dealer for available options.

CAT, CATERPILLAR, SAFETY.CAT.COM, their respective logos, "Caterpillar Yellow" and the POWER EDGE trade dress, as well as corporate and product identity used herein, are trademarks of Caterpillar and may not be used without permission.

AEHQ5933 (12-2007)
Replaces AEHQ0546-03

CATERPILLAR[®]
Courtesy of Machine.Market