

938G Series II

Wheel Loader



Engine

Engine Model	Caterpillar® 3126B with ATAAC	
Flywheel Power	119 kW	160 hp
Max. Flywheel Power	134 kW	180 hp

Weights

Operating Weight	13 452 kg	29,657 lb
------------------	-----------	-----------

Buckets

Bucket Capacities	2.3-3.0 m ³	3.0-4.0 yd ³
-------------------	------------------------	-------------------------

938G Series II Wheel Loader

Setting the standard for wheel loader productivity, durability, and comfort.

Engine

- ✓ Cat® 3126B ATAAC diesel engine delivers stronger performance, faster response and excellent fuel economy. The 938G II meets all world-wide emissions regulations through 2006. **pg. 4**

Power Train

- ✓ Countershaft transmission with automatic shift capability provides on-the-go speed and direction changes. Electronic Clutch Pressure Control (ECPC) delivers smoother shifts. New Variable Shift Control feature matches shift patterns to the application. **pg. 5**

Cooling System

- ✓ New G Series II cooling package reduces radiator plugging and contributes to increased fuel efficiency. Reverse air flow, an on-demand fan and a more accessible system keep the machine running cool in tough airborne debris applications. **pg. 6**

Quick Couplers And Work Tools

Add versatility to your Series II machine with a factory installed Quick Coupler, plus Work Tools and Specialty Buckets offered by Caterpillar. **pg. 11**

Serviceability

Easily perform daily maintenance up to 250-hour service intervals with ground-level access to all major service points including sight gauges for level checks of engine coolant, hydraulic and transmission oil. **pg. 12**

Performance you can feel, with powerful breakout force, fast cycle times and smoother shifts for optimal productivity and operator comfort.



Environmental Features

- ✓ The electronically controlled 3126B ATAAC engine in the 938G Series II has low exhaust emissions and meets Tier 2 regulations. Sampling valves and ecology drains help prevent fluid spills. **pg. 7**

Operator Station

- ✓ The 938G Series II has several cab enhancements including floor mounted pedals and a redesigned instrument panel. **pg. 8**

Buckets and Ground Engaging Tools

Choose from General Purpose, Material Handling or Quick Coupler Buckets, matched with a variety of Ground Engaging Tool options to precisely fit your application. **pg. 10**

Complete Customer Support

In addition to machine selection, Cat dealers offer a wide range of services, from purchase options to operator training, maintenance programs and parts support. **pg. 14**



✓ *New Feature*

Engine

The 938G II provides more power, excellent fuel economy, and reduced maintenance.



Powerful Performance. The 3126B ATAAC engine delivers net power of 119 kW (160 hp), and meets EPA Tier 2 emissions standards. Its advanced system keeps fuel at low pressure in the fuel lines until it is injected into the cylinder. Fuel pressure is created hydraulically in response to a signal from the ADEM III™ Electronic Control Module.

Electronic Control Module. The Advanced Diesel Engine Module (ADEM III) fuel system is a proprietary electronic control module, which provides improved engine response and fuel efficiency, plus advanced diagnostics and reduced emissions. Altitude capability is increased to 3050 meters (10,000 feet) without derating. ADEM III allows full electronic integration of the engine and transmission for maximum power train efficiency.

Turbocharged, ATAAC. Turbocharging packs dense air into the cylinders for more complete combustion and lower emissions. Air-to-air aftercooling (ATAAC) provides a separate cooling system for intake manifold air. The ATAAC system reduces smoke and emissions by providing cooler inlet air for more efficient combustion.

Constant Net Horsepower. The 938G II's electronic engine is integrated with an on-demand cooling fan. The engine compensates for varying fan loads and provides constant net horsepower, regardless of operating conditions. A consistent level of "working" horsepower is provided and fuel consumption is reduced.

Oil Change Intervals. The engine oil change interval is increased to 500 hours (with CH-4 oil), reducing costs and downtime.

Power Train

Advanced Caterpillar power train is reliable and fuel efficient.

Electronic Power Shift Transmission.

The electronic power shift transmission with automatic shift capability is a countershaft design built by Caterpillar. It is electronically controlled and allows full power shifts and directional changes. Fully modulated gear shifts contribute to operator comfort and increase component life.

Electronic Clutch Pressure Control (ECPC).

Senses input from both the transmission and the operator controls in the cab to modulate each individual clutch through a proportional electro-hydraulic valve. This results in smoother gear changes and improved shift quality. Energy is modulated into the clutches, resulting in longer clutch life.

Integrated Braking System. New for G Series II, IBS integrates downshifting and transmission neutralization into the left-hand brake pedal. IBS provides smooth, optimized transmission neutralizer performance with a greater range of adjustability. The Integrated Braking System also lowers owning and operating costs by reducing axle oil temperatures, which can extend service brake life.

Easy Service. Daily transmission oil level check is done from the ground through a well-protected sight gauge. An oil sampling valve allows quick, clean access to the transmission for S·O·SSM oil analysis.

Variable Shift Control. New transmission feature which allows the operator to select one of three different shift patterns based on the application and operating preferences. VSC reduces fuel consumption in many applications. In all modes, full machine power remains available for loading.

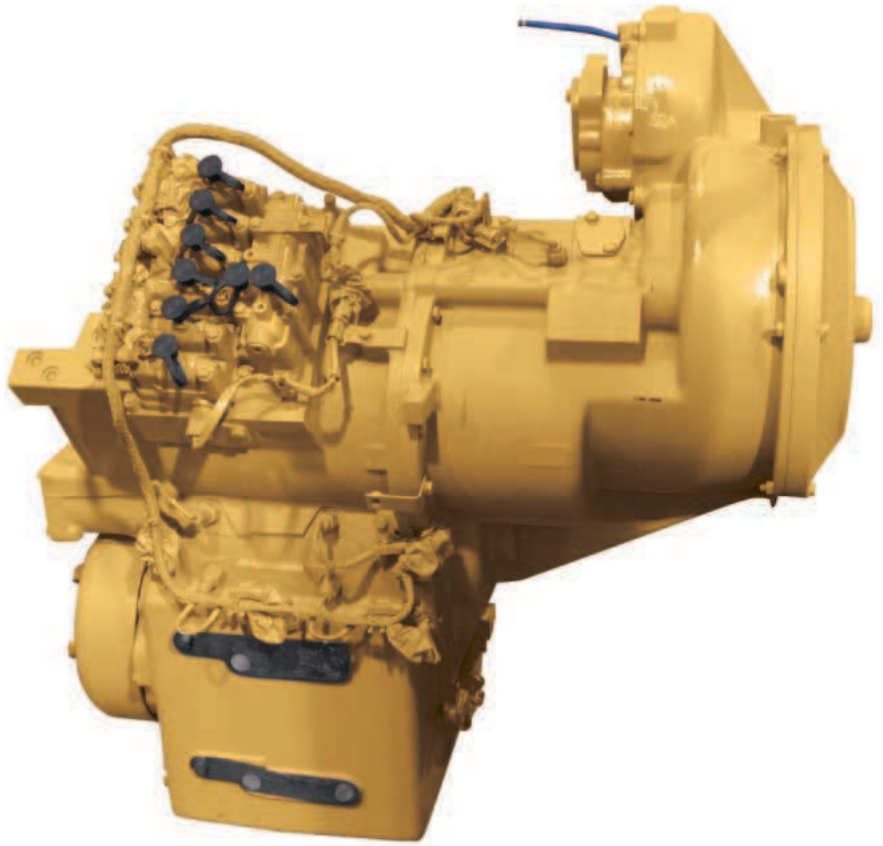

Traction Control System. The Caterpillar exclusive Traction Control System traction aid (attachment) has been improved for G Series II. Sensors and connectors have been upgraded for longer life. A new lighted cab switch indicates when the TCS system is "on."

The Traction Control System measures axle shaft rotation and vehicle articulation. When a tire slips in poor underfoot conditions the system applies the service brake and torque is transferred through the differential to the opposite side wheel with better traction. TCS is fully automatic, works on all four wheels independently and combines the maneuverability of an open differential with the power of a limited slip.

Cooling System

New G Series II cooling package reduces radiator plugging and improves fuel efficiency.



Reverse Flow. Air enters through the rear grill and exits out the top opening and side hood doors. Rear air flow picks up less debris from the ground, reducing plugging.

Improved System Access. The 938G II adds a swing-out grill, hydraulic oil cooler and air conditioner condenser for easier cleaning. Side panels open to allow access to both sides of all cores for cleaning. A heavy duty Airborne Debris Grill, with 4 mm perforations is available as an attachment.

On-Demand Fan. Electronically controlled, variable speed on-demand fan adjusts to meet the varying cooling requirements of the machine. Fan speed is determined by oil, coolant and inlet manifold temperatures. In cooler operating conditions, average fan speed is reduced, resulting in less fuel consumption, lower noise levels and less radiator plugging.

Unit Core Radiator. New unit core radiator with square wave shaped fins. Lower fin density (6 fins per inch) allows debris to pass through more easily.

Environmental Features

Caterpillar cares about the environment and continues to develop innovative solutions.



Low Exhaust Emissions. The Cat 3126B ATAAC engine used in the 938G Series II is a low emission engine designed to meet Tier 2 emission regulations. It is electronically controlled, with air-to-air aftercooling for more efficient combustion and cleaner emissions.

Reduced Sound. The electronic on-demand fan automatically regulates fan speed depending on cooling requirements. The fan draws less horsepower in cooler ambient temperatures, which reduces fuel consumption. Sound levels are also reduced when the fan slows down. There is additional insulation around the engine to reduce sound levels.



Environmental Fluids. Extended Life Coolant/Antifreeze with anti-foaming and anti-corrosion properties provide extended service intervals (up to 6000 hours) and requires less frequent fluid changes and disposals. Air conditioning refrigerant is CFC-free.

Fewer Leaks And Spills. Oil sampling valves and pressure test ports are included for easy service diagnostics, with less chance of spills. Filters are positioned vertically and located for easy access, allowing for removal without fluid spillage.

Ecology Drains. Standard for the engine, transmission, hydraulics, radiator and fuel. Activating the valve allows fluid to be drained into a container without spillage. Axle oil ecology drains are an attachment and allow quicker oil changes with reduced spillage.

Rebuildable Components. Many major components are designed to be rebuilt. Worn components can be remanufactured instead of thrown out.

Operator Station

The ultimate in wheel loader operator comfort and efficiency.



1 Steering. Low effort hand metering unit steering. Tilt steering column helps fit the wheel to the operator. Load sensing steering directs power through the steering system only when needed. When not steering, more engine power is available to generate rimpull, breakout and lift forces.

2 Excellent Visibility. The front window provides remarkable forward and peripheral viewing, including the machine wheels and bucket corners. Bonded glass in the windshield eliminates frame obstructions. The sloping hood provides excellent visibility to the rear of the machine.

3 Finger Tip Controls. New pilot-assisted hydraulic implement controls deliver comfortable, low-effort operation. Single lever joystick and lift lever F-N-R switch are available as attachments.

4 New Instrument Cluster. Gauges, status indicators and alert indicators are now centrally located. 3-level warning system monitors key functions. The system alerts the operator of immediate or impending problems with engine oil pressure, parking brake, fuel pressure, electrical system, brake oil pressure, hydraulic oil temperature, transmission filter bypass, engine inlet manifold temperature, primary steering oil pressure and the air inlet heater. LED warning indicators with no bulbs to replace.

5 Cab Access. Left and right side doors swing open 180 degrees and latch for optimal ventilation, visibility and communication to ground level. Left and right side sliding windows are available as an attachment. Full service platforms are provided on both sides of the machine for safety and easy maintenance access.

6 Floor Mounted Pedals. All pedals, including the new electronic governor, are floor mounted for greater operator comfort. Left pedal incorporates the new Integrated Braking System that combines service brake, transmission neutralizer and downshift functions.

7 Generous Storage Space. Compartments for lunchbox, coolers and cups.

8 Seat Options. The standard cloth and vinyl seat adjusts 6 ways. A new Caterpillar Contour air suspension seat (attachment) provides increased operator comfort with 6-way adjustment and automotive-style lumbar support.

9 Electronic Autoshift Control. Set for manual or one of two fully automatic shifting modes.

10 Ride Control System Switch. Attachment that reduces fore and aft pitch for a smoother, more comfortable ride. Allows the selection of three different modes: Off – always off service. On – always in service. Auto – the system is automatically actuated when the machine travels at a speed greater than 9 km (6 mph).

11 Transmission Neutralizer Lockout Switch. Rocker switch that locks out the neutralizer. Defaults back to neutralizer “on” upon machine start up.

12 Variable Shift Control. Allows the operator to select three different shift patterns based on application and working preferences. Normal, Economy and Aggressive modes. Lowers sound levels and fuel consumption and provides smoother shifts.

Radios. 12-volt converter (5-amp), speakers, antenna, wiring and brackets for entertainment radio installation. Factory installed AM/FM/Cassette radio is now available as an attachment.

Buckets and Ground Engaging Tools

Choose from General Purpose, Material Handling or Quick Coupler Buckets, matched with a variety of Ground Engaging Tool options to precisely fit your application.



General Purpose Buckets. Perform well in a broad range of applications including excavation, stockpiling and dozing. Proven shell and tine construction. GP buckets accept standard Caterpillar bolt-on cutting edges or bolt-on teeth. Four basic bucket sizes are available. Buckets are rebuildable.

Material Handling Buckets. Flat floor Opti-Profile designs for free-flowing material (stockpile applications). Two basic bucket sizes are available. Uses Corner Guard System bolt-on edges.

Quick Coupler Buckets. General Purpose profile, compatible with factory installed horizontal pin-lock quick coupler. Three sizes available.

Specialty Buckets. Refuse, Multi-Purpose, and Coal buckets are available for industry specific applications.

Bolt-On Cutting Edge. Reversible, for superior strength and wear life. Standard, Heavy-duty edge, (providing 50% more wear life) or Abrasion Resistant Material (ARM) edge are available. Corner Protectors complete the system.

Bolt-On Teeth. Two-bolt corner adapter is securely attached to prevent shifting. Bolt-on two-strap center adapters. Seven tip options are available with heavy-duty retention system.

Bolt-On Teeth and Edge Segments. Standard reversible segments protect the base edge between teeth, and eliminate scalloping. Heavy-duty reversible segments (providing 50% more wear life) are also available.

Rear Wear Plates. Replaceable rear wear plates provide bucket bottom protection.

Quick Couplers And Work Tools

Add versatility to your Series II machine with a factory installed Quick Coupler, plus Work Tools and Specialty Buckets offered by Caterpillar.

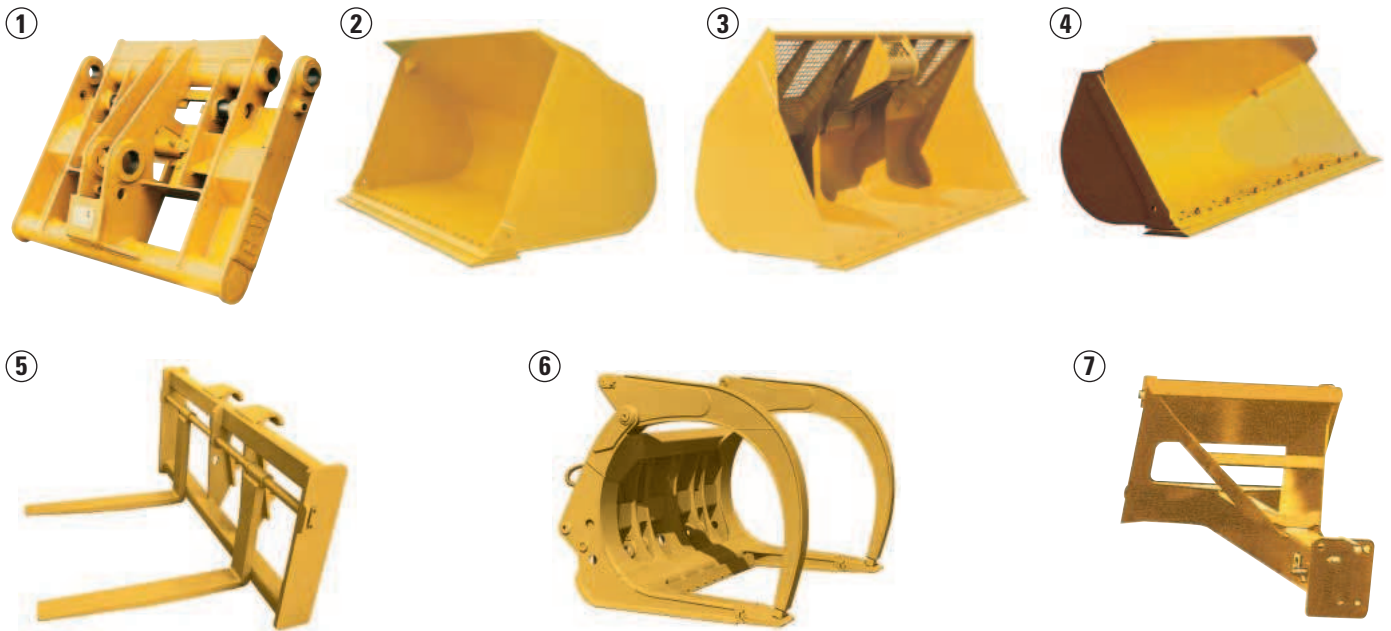

1 Quick Couplers. Provide outstanding versatility and allow one machine to perform a wide variety of tasks. Factory installed, with steel hydraulic lines and a clean routing down the lift arms. In-cab electric actuation, with safety lock-out switch. Horizontal pin-grabber design.

2 Coal Buckets. Flat floor for stockpile applications. Coal buckets include bolt-on cutting edges.

3 Woodchip Buckets. Are specially designed to load woodchips, and other light materials. Flat floor. Bolt-on cutting edges are standard. Screens help visibility when loading.

4 Side-Dump Buckets. Permit loaders to operate in congested worksites and can also dump forward like a conventional bucket (3rd valve required).

5 Forks. Pallet forks are ideal work tools for material handling tasks. Available in a variety of tine lengths.

6 Log Forks With Top Clamp. For tree length or cut to length logs. Lumber and log forks are also available.

7 Material Handling Arm. Material handling arm with adjustable lengths and load capacities can serve as a crane on the jobsite.

Plows. Hydraulic reversible plows angle 30°, left or right. This reversing action is ideal for cleaning applications on mountain roads, airports, parking lots, plant facilities, etc.

A complete range of Work Tools are available from your Caterpillar dealer.

Serviceability

The 938G Series II continues Caterpillar leadership in wheel loader serviceability.



Ground Level Maintenance Points.

All service points, including color-coded S•O•S sampling ports are accessible from ground level. Remote grease lines culminate in two convenient central lube banks in the right hitch area.

Sight Gauges. For the transmission oil, hydraulic oil and radiator coolant are easy to see and eliminate the risk of contaminants entering the system during daily checks.

Engine Compartment. Access is convenient through service doors and side panels that can be quickly opened.

Non-Metallic Hood. Tilts for full access to engine, cooling system and major components. An electric screw-jack, with manual backup, tilts the hood up to 70 degrees.

Ecology Drains. For engine, transmission and hydraulic oil, reduces spills when draining fluids. Axle oil ecology drains are available as an attachment.

Electric Fuel Priming Pump. A new electrically actuated fuel priming pump simplifies fuel filter changes.

Engine Oil Change Intervals. Are every 500 hours with the use of CH-4 oil.

Coolant. System is factory filled with Caterpillar Extended Life Coolant, which can provide up to 6000 hours between change intervals.

Remote Pressure Taps. Are available as an attachment to make transmission diagnostics even easier.

Brake Wear Indicators. Inboard indicator allows a service technician to measure and track brake wear.

Batteries. Two maintenance-free batteries are located in a built-in battery box in the left rear frame with a sealed lid to keep moisture out.

Caterpillar Monitoring System (CMS). Provides machine performance feedback, along with diagnostic codes, which a service technician can use to quickly troubleshoot problems.



Product Link. Is a wireless communication system that provides two-way information flow between a machine and Caterpillar dealers and customers. Machines are fitted with a data module, wiring, and an antenna. The system up-links via satellite to the Caterpillar network and PC software. Product Link eliminates trips to obtain data, allows more effective maintenance scheduling and can identify unauthorized machine usage.

Product Link 201. Is available as a factory installed attachment and offers:

- Service meter hour update (one per day)
- Machine location update (four times a day)
- Mapping and route planning features
- DBS machine usage file integration
- Product Watch (configurable parameters for machine location and time operation)
- Event/diagnostic monitoring
- E-mail/pager alerts (interfaces with DBS Robot/Alert function)

Product Link 151. Is available as a dealer installed option and offers many of the PL-201 features.



Machine Security System.

A programmable system (attachment) to manage machine access and restrict unauthorized usage. Special Machine Security System keys can be programmed (using Caterpillar Electronic Technician) to deny access during specific times or days of the week.

Complete Customer Support

Cat dealer services help you operate longer with lower costs.



Machine Selection. Make detailed comparisons of the machines under consideration before purchase. Cat dealers can estimate component life, preventive maintenance costs and the true cost of lost production.

Purchase. Look past initial price and consider the many financing options available as well as day-to-day operating costs. Consider the dealer services that can be included in the cost of the machine to yield lower equipment owning and operating costs over the long run.

Customer Support Agreements.

Cat dealers offer a variety of product support agreements and can develop a plan that meets your specific needs. These plans can cover the entire machine, including attachments, to help protect your investment.

Parts Support. You will find nearly all parts at our dealer parts counter. Cat dealers use a worldwide computer network to find in-stock parts to minimize machine downtime.

Operation. Improving operating techniques can boost your profits. Your Cat dealer has training videotapes, literature and other ideas to help you increase productivity.

Maintenance Services. Choose from a variety of maintenance services when purchasing your machine. Repair option programs guarantee the cost of repairs up front. Diagnostic programs such as S·O·S and Coolant Sampling help avoid unscheduled repairs.

Component Replacement. Repair, rebuild or replace? Caterpillar offers a line of genuine remanufactured components, which can help lower repair costs. Your Cat dealer will help you evaluate the cost involved so you can make the right choice.

www.CAT.com. For more complete information on Cat products, dealer services, and industry solutions, visit us on the web at www.Cat.com.

Engine

Engine Model	Caterpillar 3126B with ATAAC	
Flywheel Power	119 kW	160 hp
Max. Flywheel Power	134 kW	180 hp
Peak Torque (Net) @ 1,400 rpm	839 Nm	619 ft-lb
Total Torque Rise	62 %	
Bore	110 mm	4.3 in
Stroke	127 mm	5 in
Displacement	7.2 L	439 in ³

- Flywheel power rating at 2,200 rpm. Maximum flywheel power rating at 1,800 rpm.
- Caterpillar 3126B engine meets EPA Tier 2 off-highway emissions regulations.
- No derating required up to 3050 m (10,000 ft) altitude.

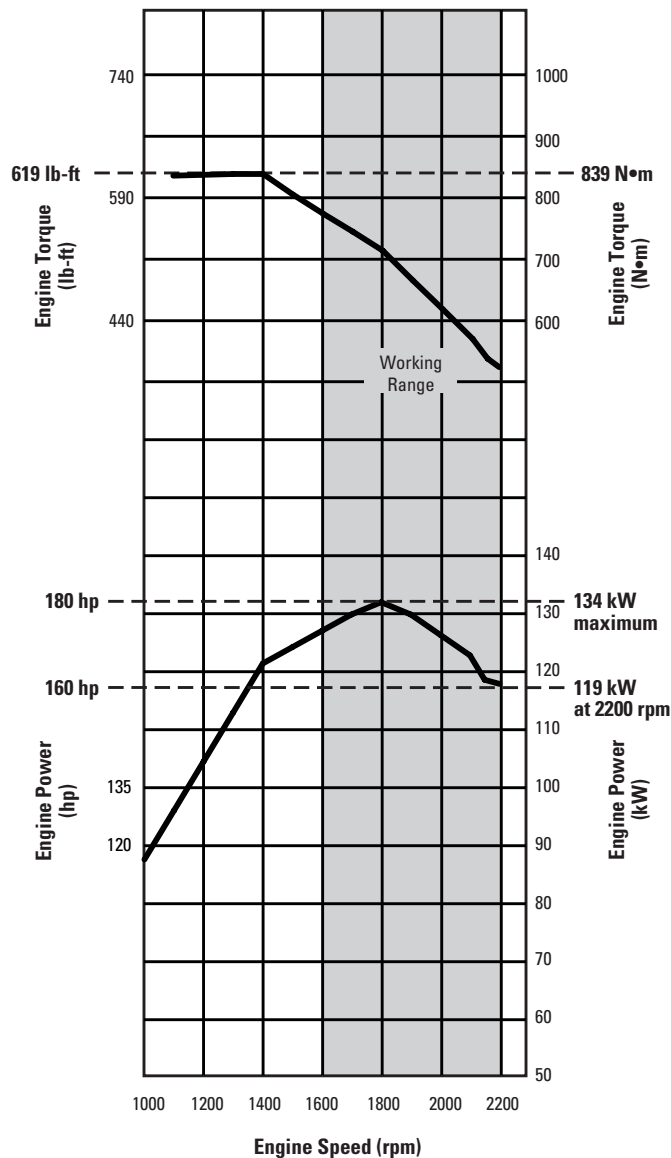

Weights

Operating Weight	13 452 kg	29,657 lb
------------------	-----------	-----------

Buckets

Bucket Capacities	2.3-3.0 m ³	3.0-4.0 yd ³
Maximum Bucket Capacity	3 m ³	4 yd ³

Operating Specifications

Static Tipping Load, Full Turn	9470 kg	20,878 lb
Breakout Force	109.4 kN	24,594 lb

- Operating specifications based on 2.8 m³ (3.65 yd³) GP bucket and standard 20.5-R25 tires.

Transmission

Forward 1	7.6 kph	4.7 mph
Forward 2	13.4 kph	8.3 mph
Forward 3	23.3 kph	14.5 mph
Forward 4	38.8 kph	24.1 mph
Reverse 1	7.6 kph	4.7 mph
Reverse 2	13.4 kph	8.3 mph
Reverse 3	23.3 kph	14.5 mph

- Maximum travel speeds with empty bucket and 20.5-R25 tires.

Hydraulic System

Bucket/Work Tool System – Pump Output	163 L/min	43 gal/min
Bucket/Work Tool System – Relief Valve Setting	24 800 kPa	3,597 psi
Hydraulic Cycle Time – Raise	6 Seconds	
Hydraulic Cycle Time – Dump	1.4 Seconds	
Hydraulic Cycle Time – Lower, Empty, Float Down	2.8 Seconds	
Hydraulic Cycle Time – Total	10.2 Seconds	
Pilot System – Pump Output	102 L/min	26.9 gal/min

- Bucket/Work Tool System, Vane-Type Pump – Output at 2,200 rpm and 7000 kPa (1,015 psi).
- Pilot System Piston Pump – Output at 2,200 rpm and 7000 kPa (1,015 psi).

Brakes

Brakes Meets required standards.

- Meet OSHA, SAE J1473 Oct90 and ISO 3450-1985 standards.

Axles

Front	Fixed front	
Rear	Oscillating $\pm 12^\circ$	
Maximum Single-Wheel Rise and Fall	420 mm	16.5 in

Tires

Tires Choose from a variety of tires to match your application.

- Choice of:

20.5-25 L2 Goodyear, Firestone

20.5-25 L3 Firestone, Goodyear

20.5 R25 GP2B L2 Goodyear

20.5 R25 RT3B L3 Goodyear

20.5-R25 XHA L3 Michelin

20.5-R25 XTLA L2 Michelin

550/65 R25 L3 Michelin

- NOTE: In certain applications (such as load and carry) the loader's productive capabilities might exceed the tires' tonnes-km/h (ton-mph) capabilities. Caterpillar recommends that you consult a tire supplier to evaluate all conditions before selecting a tire model. Other special tires are available on request.

Cab

ROPS/FOPS Meets SAE and ISO standards.

- Caterpillar cab with Integrated Rollover Protective Structure (ROPS) is standard in North America.
- ROPS meets SAE J1040 APR88 and ISO 3471:1994 criteria.
- Falling Objects Protective Structure (FOPS) meets SAE J231 Jan81 and ISO 3449:1992 Level II criteria.
- The operator sound pressure level measured according to the procedures specified in ISO 6394:1998 is 75 dB(A) for the cab offered by Caterpillar when properly installed and maintained and tested with the doors and windows closed.
- Hearing protection may be needed when operating with an open operator station and cab (when not properly maintained or doors/windows open) for extended periods or in noisy environment.
- The sound pressure level is 110 dB(A) measured according to the static test procedure and conditions specified in ISO 6393:1998 for a standard machine configuration.

Service Refill Capacities

Fuel Tank – Standard	257 L	67.9 gal
Cooling System	43 L	11.4 gal
Crankcase	30 L	7.9 gal
Transmission	30 L	7.9 gal
Differentials and Final Drives – Front	24 L	6.3 gal
Differentials and Final Drives – Rear	27 L	7.1 gal
Hydraulic System (Including Tank)	90 L	23.8 gal
Hydraulic Tank	76 L	20.1 gal

Dimensions

All dimensions are approximate.

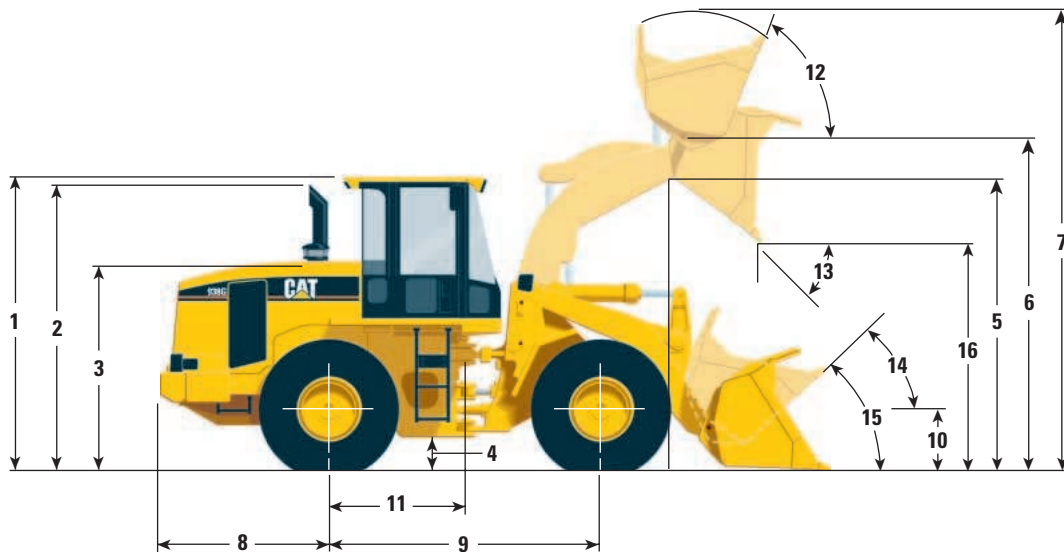

1	Height to top of ROPS	3300 mm	10'10"		
2	Height to top of exhaust pipe	3227 mm	10'7"		
3	Height to top of hood	2359 mm	7'9"		
4	Ground clearance/ Standard tire 20.5-R25 (L-2) See Chart below for other tires	399 mm	1'4"		
5	Lift arm clearance @ maximum lift	3435 mm	11'3"		
6	Bucket Pin height @ maximum lift Bucket Pin height, optional high lift	3843 mm 4266 mm	12'7" 14'0"		
7	Overall height – bucket raised	5284 mm	17'4"		
8	Center line of rear axle to edge of counterweight	1857 mm	6'1"		
9	Wheelbase	3020 mm	9'11"		
10	Height to center line of axle	688 mm	2'3"		
11	Center line of rear axle to hitch	1510 mm	4'11"		
12	Rack back @ maximum lift	65°			
13	Dump angle @ maximum lift	49°			
14	Rack back @ carry	50°			
15	Rack back @ ground	44°			
16	Dump clearance @ maximum lift and 45° dump	2771 mm	9'1"		

Tires

Tread width for all tires is 2020 mm (80")

		Width over tires		Change in vertical dimensions		Change in operating weight without ballast		Change in static tipping load – straight	
		mm	inches	mm	inches	kg	lb	kg	lb
20.5-25, (L-3)	Bridgestone	2596	102	-9	-0.4	+209	+461	N/A	N/A
550/65R25, (L-3)	Michelin	2569	101	-80	-3.1	+43	+95	0	0
20.5-25, (L-2)	Goodyear	2607	103	+24	+0.9	-60	-132	-44	-97
20.5-25 (L-3)	Goodyear	2602	102	-22	-0.9	-86	-190	+64	+141
20.5-R25 (L-2)	Michelin XTLA	2601	102	0	0	0	0	0	0
20.5-R25 (L-3)	Michelin XHA	2594	102	+6	+0.2	-170	-375	+129	+284
20.5-R25 (L-3)	Goodyear GP2B	2595	102	+10	+0.4	+127	+280	+98	+216

NOTE:

Tire options include tires and rims.

In certain applications (such as load-and-carry work) the loader's productive capabilities might exceed the tires' tonnes-km/h (ton-mph) capabilities. Caterpillar recommends consulting a tire supplier to evaluate all conditions before selecting a tire model.

Operation Specifications

General Purpose Buckets

		Bolt-on edges			Teeth and segments			Teeth		
		Bolt-on edges	Teeth and segments	Teeth	Bolt-on edges	Teeth and segments	Teeth	Bolt-on edges	Teeth and segments	Teeth
Rated capacity	m ³	2.3	2.3	2.1	2.5	2.5	2.3	2.8	2.8	2.7
	yd ³	3.01	3.01	2.75	3.27	3.27	3.01	3.66	3.66	3.53
Struck capacity	m ³	1.97	1.97	1.87	2.1	2.1	2.0	2.41	2.41	2.04
	yd ³	2.58	2.58	2.45	2.75	2.75	2.62	3.15	3.15	2.67
Width	mm	2706	2777	2777	2706	2777	2777	2706	2777	2777
	ft/in	8'9"	9'1"	9'1"	8'11"	9'1"	9'1"	8'11"	9'1"	9'1"
Dump clearance at full lift and 45° discharge	mm	2890	2786	2786	2849	2743	2743	2771	2664	2664
	ft/in	9'6"	9'2"	9'2"	9'4"	9'0"	9'0"	9'1"	8'9"	8'9"
Reach at full lift and 45° discharge	mm	984	1089	1089	1010	1114	1114	1068	1170	1170
	ft/in	3'3"	3'7"	3'7"	3'4"	3'8"	3'8"	3'6"	3'10"	3'10"
Reach with lift arms horizontal and bucket level	mm	2180	2327	2327	2230	2377	2377	2330	2447	2447
	ft/in	7'2"	7'8"	7'8"	7'4"	7'10"	7'10"	7'8"	8'0"	8'0"
Digging depth	mm	50	50	25	50	50	25	50	50	25
	in	1.9"	1.9"	0.9"	1.9"	1.9"	0.9"	1.9"	1.9"	0.9"
Overall length	mm	7181	7339	7339	7231	7389	7389	7331	7489	7489
	in	282.7"	288.9"	288.9"	284.6"	290.9"	290.9"	288.6"	294.8"	294.8"
Overall height with bucket at full raise	mm	5140	5140	5140	5188	5188	5188	5284	5284	5284
	ft/in	16'10"	16'10"	16'10"	17'0"	17'0"	17'0"	17'4"	17'4"	17'4"
Loader clearance circle with bucket in carry position	mm	11 932	12 084	12 084	11 958	12 108	12 108	12 008	12 160	12 160
	ft/in	39'2"	39'8"	39'8"	39'3"	39'9"	39'9"	39'5"	39'11"	39'11"
Static tipping load, straight*	kg	10 883	10 753	10 782	10 809	10 679	10 884	10 657	10 527	10 727
	lb	23,992	23,706	23,770	23,829	23,543	23,995	23,494	23,208	23,648
Static tipping load, articulated at full 40° turn*	kg	9683	9552	9591	9613	9483	9678	9470	9340	9530
	lb	21,347	21,058	21,144	21,193	20,906	21,336	20,877	20,591	21,010
Breakout force	kN	125.9	124.9	134.4	119.9	119.0	128.2	109.4	108.6	116.3
	lb	28,303	28,079	30,214	26,955	26,752	28,821	24,594	24,414	26,145
Operating weight*	kg	13 348	13 456	13 363	13 381	13 489	13 396	13 452	13 560	13 467
	lb	29,427	29,665	29,460	29,500	29,738	29,533	29,656	29,894	29,689

Pin-On Bucket Selection Guide

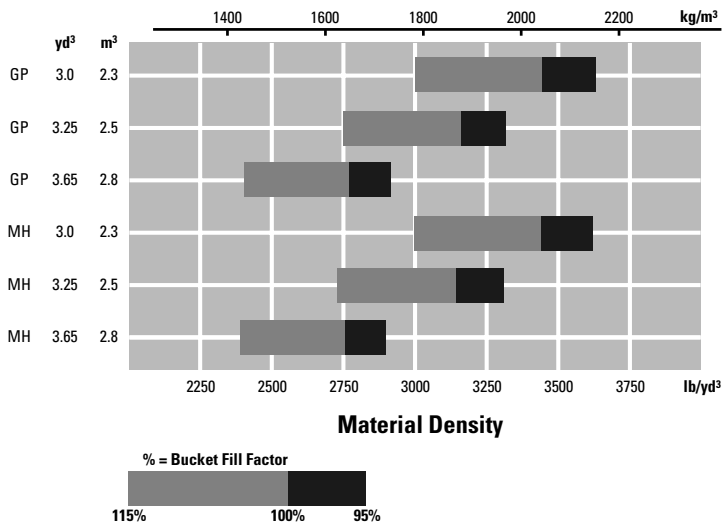

			Material Handling Buckets									Refuse Bucket
Bolt-on edges	Teeth and segments	Teeth	Bolt-on edges	Teeth and segments	Teeth	Bolt-on edges	Teeth and segments	Teeth	Bolt-on edges	Teeth and segments	Teeth	Teeth
3.0	3.0	2.9	2.3	2.3	2.1	2.5	2.5	2.3	2.8	2.8	2.7	4.2
3.92	3.92	3.79	3.00	3.00	2.75	3.27	3.27	3.00	3.66	3.66	3.53	5.49
2.66	2.66	2.55	1.98	1.98	1.89	2.13	2.13	2.03	2.42	2.42	2.32	3.73
3.48	3.48	3.34	2.59	2.59	2.47	2.79	2.79	2.66	3.17	3.17	3.03	4.88
2692	2692	2692	2706	2777	2777	2706	2777	2777	2706	2777	2777	2738
8'10"	8'10"	8'10"	8'11"	9'1"	9'1"	8'11"	9'1"	9'1"	8'11"	9'1"	9'1"	9'0"
2702	2604	2604	2827	2713	2713	2791	2678	2678	2721	2607	2607	2501
8'10"	8'7"	8'7"	9'3"	8'11"	8'11"	9'2"	8'9"	8'9"	8'11"	8'7"	8'7"	8'2"
1091	1208	1208	886	980	980	922	1016	1016	992	1086	1086	1133
3'7"	4'0"	4'0"	2'11"	3'3"	3'3"	3'0"	3'4"	3'4"	3'3"	3'7"	3'7"	3'9"
2387	2539	2539	2180	2327	2327	2230	2377	2377	2330	2477	2477	2585
7'10"	8'4"	8'4"	7'2"	7'8"	7'8"	7'4"	7'10"	7'10"	7'8"	8'2"	8'2"	8'6"
111	111	86	50	50	25	50	50	25	50	50	25	106
4.3"	4.3"	3.3"	1.9"	1.9"	0.9"	1.9"	1.9"	0.9"	1.9"	1.9"	0.9"	4.1"
7437	7590	7590	7181	7339	7339	7231	7389	7389	7331	7489	7489	7631
292.7"	298.8"	298.8"	282.7"	288.9"	288.9"	284.6"	290.9"	290.9"	288.6"	294.8"	294.8"	300.4"
5194	5194	5194	5129	5129	5129	5176	5176	5176	5272	5272	5272	5541
17'0"	17'0"	17'0"	16'10"	16'10"	16'10"	17'0"	17'0"	17'0"	17'4"	17'4"	17'4"	18'2"
12 076	12 156	12 156	11 932	12 084	12 084	11 958	12 108	12 108	12 008	12 160	12 160	12 216
39'7"	39'11"	39'11"	39'2"	39'8"	39'8"	39'3"	39'9"	39'9"	39'5"	39'11"	39'11"	40'1"
10 618	10 429	10 635	10 844	10 717	10 917	10 757	10 629	10 827	10 586	10 456	10 653	9086
23,408	22,991	23,446	23,906	23,626	24,067	23,715	23,432	23,869	23,338	23,051	23,485	20,031
9450	9261	9458	9651	9524	9714	9569	9441	9629	9408	9278	9464	8004
20,833	20,416	20,851	21,276	20,996	21,415	21,096	20,813	21,228	20,741	20,454	20,864	17,645
105.0	103.2	110.5	126.0	125.0	135.2	119.9	119.1	128.3	109.5	108.7	116.4	84.9
23,605	23,200	24,841	28,326	28,101	30,394	26,955	26,775	28,843	24,617	24,437	26,168	19,086
13 325	13 435	13 342	13 336	13 444	13 351	13 370	13 478	13 385	13 437	13 545	13 452	14 113
29,376	29,619	29,414	29,400	29,638	29,433	29,475	29,713	29,508	29,623	29,861	29,656	31,113

Operation Specifications

		Quick Coupler Buckets									High Lift Delta**
		Bolt-on edges	Teeth and segments	Teeth	Bolt-on edges	Teeth and segments	Teeth	Bolt-on edges	Teeth and segments	Teeth	
Rated capacity	m ³	2.4	2.4	2.3	2.7	2.7	2.5	2.9	2.9	2.7	
	yd ³	3.14	3.14	3.00	3.53	3.53	3.27	3.79	3.79	3.53	
Struck capacity	m ³	2.02	2.02	1.92	2.35	2.35	2.25	2.48	2.48	2.36	
	yd ³	2.64	2.64	2.51	3.07	3.07	2.94	3.24	3.24	3.09	
Width	mm	2692	2692	2692	2692	2692	2692	2692	2692	2692	
	ft/in	8'10"	8'10"	8'10"	8'10"	8'10"	8'10"	8'10"	8'10"	8'10"	
Dump clearance at full lift and 45° discharge	mm	2776	2680	2680	2720	2622	2622	2686	2588	2588	423
	ft/in	9'1"	8'10"	8'10"	8'11"	8'7"	8'7"	8'10"	8'6"	8'6"	1'5"
Reach at full lift and 45° discharge	mm	1007	1122	1122	1074	1190	1190	1115	1231	1231	121
	ft/in	3'4"	3'8"	3'8"	3'6"	3'11"	3'11"	3'8"	4'0"	4'0"	5"
Reach with lift arms horizontal and bucket level	mm	2275	2425	2425	2361	2514	2514	2415	2567	2567	390
	ft/in	7'6"	7'11"	7'11"	7'9"	8'3"	8'3"	7'11"	8'5"	8'5"	1'3"
Digging depth	mm	108	108	83	108	108	83	108	108	83	58
	in	4.2"	4.2"	3.2"	4.2"	4.2"	3.2"	4.2"	4.2"	3.2"	2"
Overall length	mm	7323	7473	7473	7410	7562	7562	7463	7616	7616	490
	in	288.3"	294.2"	294.2"	291.7"	291.7"	291.7"	293.8"	299.8"	299.8"	1'7"
Overall height with bucket at full raise	mm	5037	5037	5037	5145	5145	5145	5013	5013	5013	423
	ft/in	16'6"	16'6"	16'6"	16'11"	16'11"	16'11"	16'5"	16'5"	16'5"	1'5"
Loader clearance circle with bucket in carry position	mm	12 018	12 094	12 094	12 060	12 140	12 140	12 088	12 168	12 168	520
	ft/in	39'5"	39'8"	39'8"	39'7"	39'10"	39'10"	39'8"	39'11"	39'11"	1'8"
Static tipping load, straight*	kg	10 489	10 325	10 527	10 392	10 211	10 415	10 297	10 128	10 333	(2916)
	lb	23,124	22,762	23,208	22,910	22,533	22,961	22,700	22,328	22,780	(6429)
Static tipping load, articulated at full 40° turn*	kg	9329	9165	9358	9223	9057	9252	9148	9030	9176	(2643)
	lb	20,566	20,205	20,630	20,333	19,967	20,397	20,167	19,907	20,229	(5829)
Breakout force	kN	115.9	114.4	123.1	107.0	105.6	113.1	102.3	100.8	107.8	(5.3)
	lb	26,055	25,718	27,674	24,055	23,740	25,426	22,998	22,661	24,234	(1191)
Operating weight*	kg	13 402	13 512	13 419	13 457	13 567	13 474	13 476	13 586	13 493	347
	lb	29,546	29,788	29,583	29,667	29,910	29,705	29,709	29,951	29,746	765

* Static tipping loads and operating weights are based on standard machine configuration (with standard 20.5-R25 L3 tire), full fuel tank, 80 kg operator, plus air conditioning, power train and crankcase guards and ride control attachment.

Specifications and ratings conform to all applicable standards recommended by the Society of Automotive Engineers, including SAE Standards J732C governing loader ratings.

** Tipping load changes for 2.8 m³ (3.65 yd³) GP bucket. Tipping load deltas vary depending on bucket selected.

Standard Equipment

Standard equipment may vary. Consult your Caterpillar dealer for details.

Electrical

- Alarm, back-up
- Alternator 52-amp
- Batteries, maintenance-free (2) 950 CCA
- Ignition key, start/stop switch
- Lighting system, halogen (6 total)
- Main disconnect switch
- Starter, electric, heavy-duty
- Starting and charging system (24-volt)

Operator Environment

- Bucket/Work Tool function lockout
- Cab, pressurized and sound suppressed
 - ROPS/FOPS, radio ready (entertainment) includes antenna, speakers and converter (12-volt, 15-amp)
- Cigar lighter and ashtray
- Coat hooks (2) with straps

Computerized Monitoring System

Instrumentation, Gauges:

- Digital gear range indicator
- Engine coolant temperature
- Fuel level
- Hydraulic oil temperature
- Speedometer/Tachometer
- Transmission oil temperature

Instrumentation, Warning Indicators:

- Air intake heater
- Electrical, alternator output
- Engine inlet manifold heater
- Engine oil pressure
- Fuel pressure
- Parking brake
- Primary steering oil pressure
- Service brake oil pressure
- Transmission filter bypass

Controls, lift and tilt function

- Heater and defroster
- Horn, electric (steering wheel mounted)
- Lunchbox, beverage holders, personal tray
- Mirrors, rearview (internally mounted)
- Seat, KAB (cloth) mechanical suspension
- Seatbelt, retractable, 76 mm (3 in) wide
- Steering column, adjustable, tilt
- Wet-arm, wipers/washers (front and rear)
 - Intermittent front wiper

Power Train

- Brakes, full hydraulic enclosed wet-disc
 - with Integrated Braking System (IBS) and brake wear indicator pin
- Driveline, extreme service
- Engine, Cat 3126B diesel with ATAAC
- Fan, radiator, variable speed, on demand
- Filters, fuel, primary/secondary
- Fuel priming pump (electric)
- Fuel/water separator
- Muffler, sound suppressed
- Precleaner, engine air intake
- Radiator, unit core (6 fins per inch) with ATAAC
- Starting aid (air inlet heater)
- Switch, transmission neutralizer lockout
- Torque converter
- Transmission, automatic countershaft power shift (4F/3R)
 - Variable Shift Control (VSC)

Other Standard Equipment

- Automatic bucket positioner
- Counterweight
- Doors, service access (locking)
- Ecology drains (engine, transmission and hydraulic oil)
- Fenders, steel front and rear
- Hitch, drawbar with pin
- Hood, non-metallic power tilting
- Kickout, lift, adjustable
- Linkage, Z-bar, cast crosstube/tilt lever
- Product Link Ready
- Sampling valves (engine, transmission)
- Sight Gauges:
 - Engine coolant
 - Hydraulic oil level
 - Transmission oil level
- Vandalism protection caplocks

Hydraulics

- Couplings, Caterpillar O-ring face seals
- Diagnostic pressure taps
- Hoses, Cat XT™
- Hydraulic oil cooler (swing-out)
- Steering, load sensing

Antifreeze

- Premixed 50% concentration of Extended Life Coolant with freeze protection to -34° C (-29° F).

Optional Equipment

Optional equipment may vary. Consult your Caterpillar dealer for details.

Air conditioner	Open canopy
Alternator, heavy-duty (70 amp)	Payload Control System
Axle ecology drain	Precleaner, turbine
Axle oil cooler	Precleaner, turbine/trash
Axle oil temperature monitor	Product Link 201
Buckets and Work Tools	Quick coupler
Bucket Ground Engaging Tools – see dealer	Radio, AM/FM, cassette
CB radio ready (20-amp)	Remote pressure taps
Differentials, limited slip (front or rear), No-SPIN (rear axle only)	Ride control system, two-and three-valve
Fender extensions	Seat, air suspension
Fenders, narrow	Security system
Grill, airborne debris	Sliding windows, cab
Guard, power train	Steering, secondary
Heater, engine coolant (120V or 240V)	Sunscreen, rear
High lift arrangement	Switch, lift lever F-N-R
Hydraulic arrangement, three-valve	Tires
Joystick control	Traction Control System
Lights, directional	Value package
Lights, roading	Visor, front
Lighting, auxiliary (4)	Waste Handling Arrangement
Mirrors, rearview, external	Wiper, rear

Notes

938G Series II Wheel Loader

AEHQ5538-02 (9-03)
(Replaces AEHQ5538-01)

For more complete information on Cat products, dealer services,
and industry solutions, visit us on the web at www.CAT.com

© 2003 Caterpillar
Printed in U.S.A.

Materials and specifications are subject to change without notice.
Featured machines in photos may include additional equipment.
See your Caterpillar dealer for available options.

CATERPILLAR[®]