



950H

Wheel Loader



Cat® C7 Diesel Engine with ACERT™ Technology

Gross Power (SAE J1995)	162 kW/220 hp
Net Power (ISO 9249) at 1800 rpm	147 kW/200 hp
Bucket Capacity	2.7 to 4.0 m ³
Operating Weight	18 400 to 19 500 kg

950H Wheel Loader

H-Series Wheel Loaders – The New Standard For Midsize Loaders

Reliability and Durability

- Proven Components And Technology
- ACERT Technology Maintains Performance, Efficiency And Durability While Meeting Emissions Regulations
- Heavy Duty Components Stand Up To All Operating Conditions
- Strong, Solid Structures Built To Last

pg. 4

Productivity and Versatility

- Improved Cycle Times With Load-Sensing Hydraulic System
- Constant Net Horsepower Through The Operating Range
- Aggregate Autodig Automates The Loading Process
- Special Machine Arrangements For Specialized Applications
- Large Variety Of Cat® Work Tools

pg. 6

Performance you can feel with the capability to work in the most demanding applications. Unmatched operator comfort and efficiency in a world class cab. Revolutionary electronics and hydraulics for low-effort operation. Increased productivity with lower owning and operating costs.



Operator Comfort

- Easy Entry And Exit
- Excellent Visibility
- Comfortable Environment With Controlled Vibration
- Choice of Steering And Implement Control Systems

pg. 8

Serviceability

- Service Centers For Convenient Maintenance
- Exceptional Access To Service Points
- Monitoring Systems And Dealer Support Reduce Unexpected Downtime

pg. 10

Owning and Operating Cost

- Proven Fuel Efficiency
- Superior Maintenance
- Electronic Systems Monitor Product Health And Performance
- Complete Dealer Support

pg. 12



Reliability and Durability

The Cat 950H – Built Strong and Tough – Tested And Proven – Ready To Work

- Proven components and technology
- Electronic systems monitor vital machine components
- ACERT Technology maintains engine performance, efficiency and durability while reducing emissions
- Heavy duty components withstand all operating conditions

Proven Reliability. The 950H features many of the components designed and proven in previous 950 models – all contribute to the reliability of the 950H:

- Frames
- Axles
- Planetary powershift transmission
- IBS – Integrated Breaking System
- Separated cooling system
- Cab

Engine. EU Stage IIIA compliant C7 engine with ACERT Technology combines proven systems with innovative new technologies to precisely deliver fuel to the combustion chamber. It maintains engine performance, efficiency and durability while dramatically reducing emissions.

The Cat C7 is a 7.2 L displacement, 6-cylinder, electronically governed engine. Electronic fuel injection is provided through the well-proven Caterpillar hydraulically actuated, electronically controlled unit injection (HEUI) system. A wastegate turbo-charger, equipped with a titanium wheel for improved durability, combined with air-to-air aftercooling (ATAAC) provides consistent high horsepower with increased altitude capability.

Electronic Controller. The engine is governed by the ADEM A4 electronic control module. The controller continually adjusts engine output based on load demand using a series of sensors located on the machine and engine.



Hydraulically Actuated Electronic Unit Injectors (HEUI). The HEUI system has been at work in Cat engines across the product line with a proven track record of consistent, durable, reliable performance.

Engine Block and Pistons. The gray cast iron engine block is made of the same material as the cylinder heads. Wall diameters are thicker than in previous designs while adjustments have been made to reduce sound levels and increase rigidity. One-piece all-steel pistons are housed within a wet, replaceable cast iron cylinder liner constructed of high-strength, heat-treated castings. Steel-forged connecting rods are larger in diameter.

Powershift Transmission. The 950H continues to use heavy-duty powershift transmission technology proven on previous models and currently used up through the largest wheel loader built by Caterpillar – the 994F. The planetary powershift transmission features heavy-duty components to handle the toughest applications. Built-in electronic controls enhance productivity and durability.

Throttle Shifting Control.

Controlled Throttle Shifting regulates engine speed during high-energy directional changes for smoother shifting and longer component life.

Caterpillar Designed Components.

Components used to build Cat Wheel Loaders are designed and manufactured to Caterpillar quality standards to ensure maximum performance even in extreme operating conditions.

Engine electronic control module and sensors are completely sealed against moisture and dust. Deutsch connectors and electrical wire braiding ensure that electrical connections resist corrosion and premature wear.

Hoses are engineered and manufactured for high resistance to abrasion, excellent flexibility and easy installation and replacement.

Caterpillar hose couplings use o-ring face seals to provide positive sealing for durable leak-free connections.

Heavy duty components reduce the risk of leaks, corrosion and premature wear increasing uptime and helping to protect the environment.

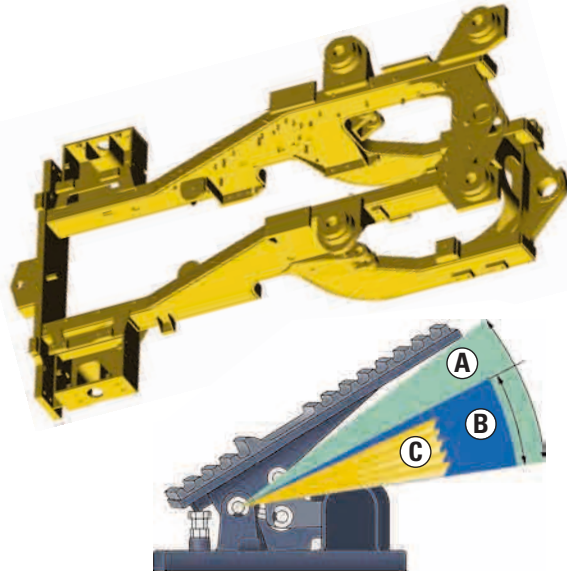
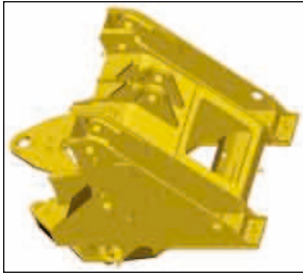

Caterpillar Monitoring System.

The 950H is equipped with the Cat Monitoring System (CMS) that keeps watch over the health of your loader. CMS monitors critical engine system functions and will derate the engine to protect itself from damage if needed. Depending on which of the following six critical conditions arise, the CMS monitor or front panel will display warning lights and sound audible alarms.

- High coolant temperature
- High air inlet temperature
- Low engine oil pressure
- High fuel pressure
- Low fuel pressure
- Engine over-speed

Axles. The 950H axles are designed by Caterpillar for durability in all operating conditions. The front axle is rigidly mounted to the frame to support the weight of the wheel loader and withstand internal torque loads as well as external forces encountered throughout operation. The rear axle is designed to allow $\pm 13^\circ$ oscillation. All four wheels remain on the ground over uneven terrain providing excellent stability and traction.

Integrated Braking System (IBS).

The Cat exclusive Integrated Braking System reduces axle oil temperatures and improves transmission neutralizer smoothness. IBS has a direct impact on durability of the axles and brakes especially in applications involving long distances and/or heavy braking.

- A** Downshift logic only
- B** Brake application initiated
- C** Self-adjusting transmission neutralization

Structures. The articulated frame design of the 950H features a durable box-section engine frame and rigid four-plate loader tower that is robotically welded. Robotic welding creates frame joints with deep plate penetration welds and excellent fusion for maximum strength and durability.

Rear Frame. A full box-section engine end frame with hitch plates at the front end provides a strong, rigid structure that resists twisting and impact loads. The result is an extremely solid mounting platform for the engine, transmission, axle, ROPS and other accessories.

Spread Hitch. The distance between the upper and lower hitch plates is important for machine performance and component life. The Cat spread hitch design provides excellent load distribution and bearing life. Both the upper and lower hitch pins pivot on double tapered roller bearings – improving durability by distributing both vertical and horizontal loads over a larger surface area. The wide opening also provides excellent service access.

Front Frame. The non-engine end frame provides a solid mounting base for the front axle, lift arms, lift cylinders and tilt cylinder. The fabricated, four-plate loader tower absorbs the forces associated with loading, twisting and penetration.

Linkage. The 950H linkage is a single-tilt Z-bar design. Z-bar linkage generates excellent breakout force and good rack back angle for better bucket loading and load retention. The Z bars' light weight compared to other linkage designs allows for more payload capacity. Lift arms are solid steel, providing superior strength with an excellent front end viewing area. The proven design offers excellent dump clearance and reach for exceptional matching to on- and off-highway trucks. Rotary sensors, for the tilt lever and lift circuit allow the operator to electronically set detent positions from the cab.

Productivity and Versatility

Work Smart And Move More



- Load sensing hydraulics increase lifting capacities
- Electro hydraulic controls reduce cycle times
- Consistent horsepower regardless of conditions
- A variety of buckets and work tools for many applications

Load Sensing Hydraulics. The 950H features a load sensing hydraulic system that automatically adjusts to operating conditions to provide only the hydraulic flow required by the implement for improved fuel efficiency.

With the new Priority Proportional Pressure Compensation Valve, implement control is improved over the previous system – raise/lower and rack back/dump can be operated simultaneously and fine modulation is repeatable for improved productivity. Operators will notice enhanced ease of operation, more rimpull into the pile and a 20% increase in lift force.

Electrohydraulic Implement Controls. Finger Tip Electro hydraulic implement controls on the 950H provide the operator with responsive, smooth and precise control of bucket and lift arms. The implement control console also features a Forward/Neutral/Reverse switch allowing easy and fast directional changes that helps reducing cycle times.



The standard programmable automatic kick-outs provide flexibility and productivity for precise load and dump target heights. Tilt, lift and return-to-dig kickouts are set by positioning the bucket or work tool and setting a rocker switch in the cab.

Constant Horsepower. On many competitive machines, gross horsepower is constant, meaning that net engine power available for actual work will vary based on demands made from parasitic sources, such as air conditioning or cooling fans. The Cat C7 engine is electronically configured to provide constant net horsepower at full parasitic load enhancing productivity and improving fuel efficiency.

Separated Cooling System. Many competitive loaders use cooling systems that pull air in from the sides, through the engine compartment and exhaust it out the rear of the machine. The 950H cooling system is isolated from the engine compartment by a non-metallic shield. The hydraulically driven, variable speed fan draws in clean air from the rear of the machine and exhausts it out the sides and top of the hood. The end results are optimal cooling efficiency, increased fuel efficiency, less radiator plugging and reduced operator sound levels.



Planetary Power Shift Transmission.

Increases number of cycles per hour. The electronic planetary power shift transmission with automatic shift capability is designed, developed and built by Caterpillar. The controlled power shift transmission allows full power, very responsive directional changes that have a direct impact on machine cycle times and productivity. The operator can choose between manual or autoshift modes.

Variable Shift Control. Match transmission shifting patterns to machine application requirements. Variable Shift Control (VSC) improves shift quality and fuel efficiency in certain applications by allowing the transmission to upshift at lower engine RPMs.

Ride Control. The optional Ride Control System improves ride, performance and load retention when traveling over rough terrain. Operators gain confidence moving at higher speeds in load and carry operations decreasing cycle times and increasing productivity.

Aggregate Autodig. Well-received by both experienced and novice operators, the optional Aggregate Autodig fully automates the loading process.

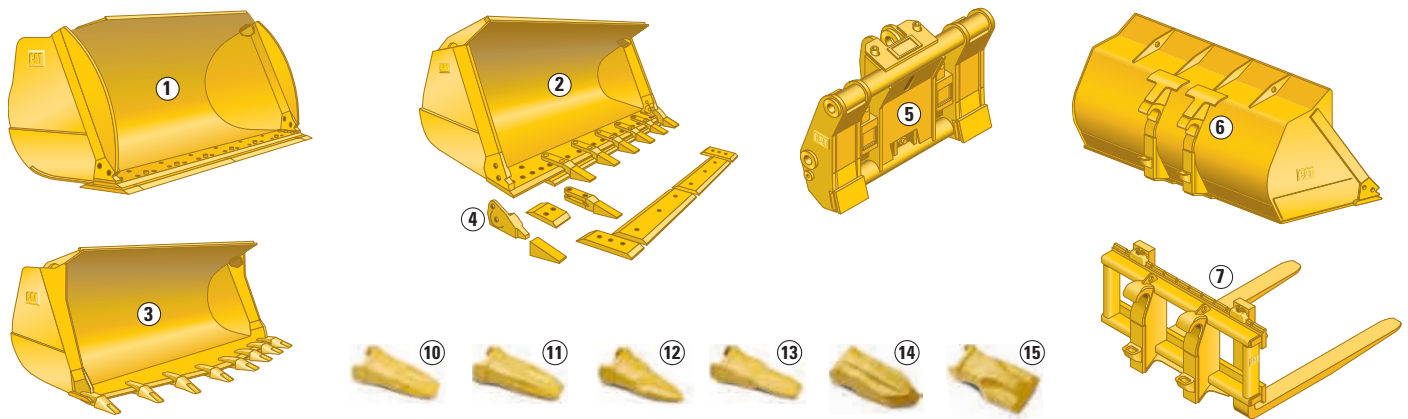

1 Universal Buckets.

This is a complete line of flat floor buckets, designed for loose material (re)handling. Equipped with various GET (Ground Engaging Tools), they provide easier pile penetration, better fill factors and faster loading cycles; they are offered in a wide range of capacities. All buckets feature bottom and side wear plates for greater durability. Universal buckets are for use with the standard lift arm configuration.

2 General Excavation Buckets.

Built to handle the toughest conditions, these buckets are excellent for bank and excavation applications. They feature proven, shell-tine construction that resists twisting and distortion. Bucket hinges are part of the structure that extends under the bucket shell to the cutting edge, forming box sections that resist impact forces. All buckets have integral spill plates that prevent possible spillage over the linkage. Replaceable rear wear plates protect the bottom of the bucket. Bucket side plates are also reinforced in their lower portion with additional wear plates. Buckets feature Corner Guard System and can be fitted with optional bolt-on GET.

3 Rock Buckets.

Caterpillar rock buckets are built to tough standards. The spade-edge design provides easier penetration and makes them well suited for high-impact jobs. Optional Ground Engaging Tools include bolt-on cutting edge and weld-on two-strap adapters to be fitted with Caterpillar K Series tips, with or without standard or heavy-duty bolt-on segments.

4 Corner Guard System. Allows maximum flexibility between teeth and edge systems for superior protection and performance in each application. Featured on General Excavation buckets and some Universal buckets.

5 Dedicated Quick Couplers.

Allow the operator to perform a wide variety of tasks with just one machine and various work tools, providing unmatched versatility and resulting in cost efficiency. With the separate optional quick coupler circuit, actuate the quick coupler and change and operate non-hydraulic work tools from the cab. The third valve can be used to actuate hydraulic work tools, like high dump buckets. The features of the vertical wedge-lock quick coupler are:

- Designed for minimal loss of breakout force
- Adjusts automatically to prevent play
- Durable design

6 Quick Coupler Buckets. A wide range of buckets fitted with dedicated quick coupler hinges is available.

Caterpillar offers you the right bucket for the right application.

7 Forks. Pallet forks are the ideal tools for handling a variety of materials. These forks are available in different sizes.

High Dump Buckets. These buckets increase the dump height of the machine and make it possible to tip loose material over high barriers. Ideal for applications as various as loading stockpiled, light material into high sided trucks, hoppers in waste transfer stations or rehandling fertilizer, coal or grain. The high dump buckets are hydraulically operated and require a 3rd valve.

K Series Tip Selection. The new Caterpillar K Series™ Tooth System holds tighter, changes easier and stays sharper.

- 10** General Duty
- 11** Extra Duty
- 12** Penetration
- 13** Penetration Plus
- 14** Heavy Penetration
- 15** Heavy Abrasion

A complete range of work tools is available from your Caterpillar dealer.

Operator Comfort

Work Comfortably And Efficiently

- Comfortable operation
- Excellent visibility
- Easy entry and exit
- Controlled vibration
- Choice of two steering systems

Operator Environment. The 950H maintains the distinction of offering the largest, most ergonomic cab in its class.

Seat. The Cat C-500 Series Comfort air suspension seat, standard in the 950H, is built strong and durable and is 6-way adjustable to accommodate all-sized operators. The cast one-piece back and seat pan prevent protrusions under the cushions. The seat features an automotive-style lumbar support for maximum comfort. The right hand armrest with integrated implement controls adjusts for comfortable, convenient operation. A heated seat option is available for additional comfort.

Vibration. By controlling normal machine vibrations, operator efficiency and productivity are improved. From the ground up, the Cat 950H is designed with many features, both standard and optional, that reduce vibration.

- The oscillating rear axle follows the contour of the ground while allowing the cab to stay steady.
- The cab is attached to the frame with iso-mounts designed to reduce shock loads from the ground.
- The articulation joint is equipped with two neutralizer valves that prevent frame-to-frame contact.
- Cylinder dampening slows the bucket as it reaches the limits of travel, preventing machine jarring.
- Ride Control is an option designed to reduce jolting and bouncing during load and carry operations.
- Electronically controlled, automatic kickouts prevent the jerking and bouncing associated with abrupt cylinder stops.
- Air suspension seat-mounted implement controls reduce vertical vibrations that come up through the cabin floor.



Steering Options. The 950H offers two steering systems to provide flexibility for your application.

Conventional Steering. The conventional steering configuration offers a low-effort hand metering unit hydraulic steering system. Load sensing steering directs power through the steering system only when needed. When not steering, more engine power is available to generate rimpull, breakout force, lift force, and results in reduced fuel consumption. The steering column tilts for maximum operator comfort.

Command Control Steering.

This is a load-sensing system that links the steering wheel and frame angle positions to provide the proper amount of steering control. The speed the machine turns is proportional to the steering wheel position. Less than 26 N steering effort is required by the operator, regardless of conditions.



Full machine articulation is accomplished with a $\pm 70^\circ$ turn of the wheel – versus two to three 360° turns of a conventional steering wheel. The Command Control Steering wheel contains the forward/neutral/reverse switch and the upshift/downshift button – allowing the left hand to remain on the steering wheel at all times. The CCS column inclines 35° and the telescopic change is up to 100 mm.



Controls. The main control panel on the 950H is located high on the right ROPS post – keeping everything within reach of the operator while maintaining visibility to the ground. Keeping all switches and controls conveniently placed allows better operator efficiency and improved productivity, while minimizing operator fatigue.

Aggregate Autodig System. It provides smoother loading cycles and consistently full payloads without touching the controls – reducing operator fatigue.

Visibility. The 950H provides excellent visibility to both the front and rear of the machine. Distortion-free flat glass stretches to the floor of the cab for excellent visibility to the bucket. Wet-arm wipers on both front and back keep the windows clean in any condition. The cab roof has channels that direct rain off the corners of the cab keeping windows clear. An overhang on all sides protects the operator from glare.

Rear Vision Camera. An optional rear vision camera is available to clearly monitor movement behind the wheel loader.

Lighting Packages. Optional lighting packages are available for roading or low-light applications. The optional High Intensity Discharge (HID) lights provide exceptional lighting for night work. A rotating beacon is available as a safety feature.

Windshield Cleaning Package. An optional windshield cleaning package provides additional steps and handrails to provide easy access for cleaning the front windows.

Entry and Exit. A ladder with self-cleaning steps keeps debris build-up to a minimum. The ladder is at a 5° forward incline for easy entry and exit. Platforms are wide allowing ease of movement to the front or rear of the machine. The main cab door opens a full 180° and latches in place to allow safe navigation to the rear of the machine. The right side door opens 10°, or completely for secondary exit simply by pulling a pin. A full-length ladder on the right side facilitates safe exit if needed.

Serviceability

Easy To Maintain – Easy To Service.



- Grouped service points and sight gauges for easy daily maintenance
- Convenient access to engine compartment for excellent serviceability
- Swing-out grill and cooling cores for easy cleaning
- Electronic systems to monitor product health

Electric Service Center. Batteries, relay panel and an optional tool box are conveniently located below the left-side access platform. The engine shutdown switch is housed with the relay panel. A compartment integrated into the access platform contains the hood tilt actuation switch, battery disconnect switch and optional jump-start receptacle.

Remote Pressure Taps. Pressure taps for the steering and hydraulic systems, transmission (optional) and brakes are grouped behind an access panel just below the right-side service platform.

Autolube. Reduce time spent on daily maintenance and downtime for unplanned repairs due to inadequate greasing with the optional Caterpillar Automatic Lubrication System. Precise lubrication of pins and bushings at specific intervals improves component wear and reduces ground contamination from excessive greasing.

S•O•S Services. Sampling valves on the 950H allow quick access to engine, transmission and hydraulic oils for S•O•S analysis. Oil change intervals and other services can be optimized according to your work schedule, reducing downtime and managing expenses.

Sight Gauges. Well-protected, yet easily visible sight gauges for the transmission oil, hydraulic oil and engine coolant allow easy daily checks while reducing the risk of contaminants entering the systems.

Brake Wear Indicators. Axles are equipped with standard brake wear indicators, allowing a technician to easily determine when it is necessary to service the brakes.



Hydraulic Service Center. Transmission oil and hydraulic oil filters are located in the Hydraulic Service Center, behind the hinged, right-side access ladder. The hydraulic oil tank can be drained from this location using the access port.

- Hydraulic oil filter change interval at 500 hours
- Transmission oil filter change interval at 1000 hours

Ground Level Grease Points. Grease fittings are grouped on the right side of the machine in two convenient locations – in a service compartment just below the right-side service platform, and a bank located just off the non-engine end frame. These locations facilitate easy lubrication of vital components located throughout the machine.



Engine Compartment Access.

The non-metallic hood on the 950H has been redesigned and restyled from previous models. Side and top panels are stronger due to more robust reinforcement ribs – the change in contour also adds to rigidity of the hood. Panels located behind the tires lift up and can be removed for additional access. Rooding fenders hinge from the rear and swing out allowing easier access to the engine compartment.



A single mechanical lift cylinder with manual back-up opens the hood. The tilting hood provides excellent access to the engine compartment, and if necessary, the entire hood can be removed with the built-in lift points. With the hood closed, quick checks of engine oil level and the coolant sight gauge can be completed through the side service doors.



Cooling System. Access for clean-out and maintenance is outstanding. The perforated and corrugated grill minimizes debris build-up and swings out for easy cleaning and access to the cooling cores. The full-width air conditioning condenser and oil cooler cores swing out 45° to allow easy cleaning of the rear radiator face. Panels on either side provide access to the front face of the radiator and ATAAC cores for easy cleaning.



Electric Priming Pump. An electric fuel priming pump located on the primary fuel filter base eliminates the need to pre-fill or manually prime filters after a change, eliminating engine contamination.

Ecology Drains. Engine, transmission and hydraulic oils can be easily drained with standard-equipment ecology drains. An axle oil ecology drain is optional.



Cab. The entire operator station can be removed in about 45 minutes and is easy to re-attach. Quick disconnects are used so no wires need to be cut and no refrigerant is lost. Cab cleaning is made easy with channels on the cab floor and no threshold at the door – the floor can be swept or mopped out easily.

Windshield Cleaning Package.

An optional windshield cleaning package consists of two steps for the loader front frame, three additional handrails and two folding mirrors. This package allows access to the entire front windshield for easy cleaning.

Complete Customer Support.

Cat field service technicians have the experience and tools necessary to service your loader on site. Technical experts at the dealership and Caterpillar can provide additional assistance to field service technicians as needed.

When on-site repair isn't enough, Cat dealerships are fully equipped to service your loader quickly.

Owning and Operating Cost

The 950H – Best Value For Your Operation



- More return for your wheel loader investment through proven Cat fuel efficiency
- Sight gauges, grouped maintenance points, easy engine access, ecology drains, maintenance-free batteries all simplify daily maintenance
- Electronic monitoring systems track product health to avoid unscheduled costly repairs
- Unsurpassed parts availability reduces downtime
- Excellent resale value provided by genuine Cat quality, outstanding dealer service and unmatched dealer support programs
- Caterpillar Financial Services and Cat dealers understand your business

Fuel Efficiency. Many manufacturers tout fuel consumption as one of the determining factors for machine acquisition, but fuel consumption is only part of the story. Productivity must also play a part in the decision.

950H Fuel Efficiency. Customer testing of the 950H is showing an improvement in fuel efficiency over the 950G II. This fuel savings are achieved through the use of

- ACERT Technology
- Engine Idle Management System software
- On-Demand Fan
- Variable Shift Control
- Free Wheel Stator Torque Converter
- Caterpillar proportional-flow load sensing hydraulic system

ACERT Technology Fuel Economy.

Based on Caterpillar testing, the fuel economy of Cat engines with ACERT technology is 3 to 5 percent better than current competing technologies. This fuel economy is directly related to the complete combustion of fuel due to the integration between the electronic control that monitors conditions, the air management system that controls air volume and the fuel injection system that delivers just the right amount of fuel as needed.

Engine Idle Management System.

The Engine Idle Management System (EIMS) maximizes fuel efficiency and provides flexibility in managing idle speeds for specific application requirements. Four idle control speeds are available.

On-Demand Fan. Temperature levels of the engine coolant, transmission oil, hydraulic oil and air inlet manifold are constantly monitored to adjust the speed of the fan to cooling requirements. Controlled fan speed improves fuel efficiency.



1 Variable Shift Control (fuel efficiency).

VSC improves shift quality and fuel efficiency in certain applications by allowing the transmission to upshift at lower engine RPMs.

2 ISO symbol for fuel efficiency

3 Economy mode (typically used for load & carry and roading applications)

4 Aggressive mode (typically used for tight truck loading applications)

Free Wheel Stator Torque Converter (FWSTC).

The free wheel stator torque converter improves power train efficiency in load and carry operations which contributes to the improved fuel efficiency of the 950H.



Maintenance. Proper maintenance of your wheel loader can help control expenses and lower your owning and operating costs. The 950H provides unmatched serviceability by offering:

- Hydraulic service center
- Electric service center
- Well-protected, easily visible sight gauges



- Ground level maintenance points
- Easy access to engine compartment
- Ecology drains for simple and clean fluid drainage
- Brake wear indicators for ease of inspection
- Airborne debris-resistant, swing-out grill provides more efficient airflow

S•O•S Services. Managing component life and machine availability decreases downtime while improving your productivity and efficiency. S•O•S Services can help you do that. Regular fluid sampling is used to track what is going on inside the equipment. Wear-related problems are predictable and easily and quickly repairable. Maintenance can be done according to your schedule, resulting in increased uptime and flexibility in maintenance and repair before failure.

Product Link. With Product Link owners can collect and track multiple types of information – from machine location and service meter hours, to health and productivity information.

EquipmentManager. With a subscription to EquipmentManager information from Product Link can be transmitted to a computer. Return on equipment investment is optimized through maintenance management and improved uptime.



Customer Support Agreements.

A Customer Support Agreement (CSA) is any arrangement between you and your Cat dealer that helps you lower your total cost per unit of production. CSAs are flexible, allowing them to be tailored to your business. They can range from simple Preventive Maintenance Kits to sophisticated Total Cost Performance Guarantees. Having a CSA with your Cat dealer allows you more time to do what you do best – run your business.



Parts Availability. Caterpillar provides an unsurpassed level of personalized service for your wheel loader. With parts distribution centers worldwide, most parts can be delivered in 24 hours. Easy access to parts reduces downtime.

Machine Security System. Stolen equipment equates to lost production and increased costs. Eliminate machine theft and unauthorized usage with the Cat Machine Security System (MSS). It is integrated into the machine's electronic system and can protect most brands of equipment by requiring a uniquely coded key to start the machine.

Caterpillar Equipment Training Solutions. A thorough understanding of machine systems and a high level of skill in operation helps achieve maximum efficiency and improves return on investment. Caterpillar Equipment Training Solutions programs help provide operators with high levels of proficiency and confidence. Contact your Cat Dealer for more information on Caterpillar Equipment Training Solutions programs.

Caterpillar Financial Services Corporation. Cat Financial understands your business, your industry and the challenges you face. That's why they can provide payment plans to fit your unique needs – and to help you achieve your goals.

Resale Value. Owning quality equipment is a very important factor in maintaining resale value. Cat not only supplies quality equipment but also provides product and dealer support to maintain the reliability and durability of your machine.

Engine

Cat C7 with ACERT Technology

Gross Power 162 kW/220 hp

Net Power at 1800 rpm

ISO 9249 147 kW/200 hp

80/1269/EEC 147 kW/200 hp

Peak Torque (net) at 1400 rpm 907 Nm

Bore 110 mm

Stroke 127 mm

Displacement 7.2 liter

- All engine horsepower (hp) are metric including front page.
- EU Stage IIIA compliant
- Rating for net power advertised based on power available when the engine is equipped with alternator, air cleaner, muffler and on-demand hydraulic fan drive at maximum fan speed.

Operating Specifications

Operating Weight 18 500 kg

Static Tipping Load,

Full Turn 11 500 kg

Breakout Force 166 kN

Bucket Capacities 2.7 to 4.0 m³

- Operating weight with 3.3 m³ universal bucket and bolt-on cutting edge.

Axles

Front Fixed

Rear Oscillating ± 13°

Maximum Single-Wheel Rise and Fall 470 mm

Sound

- The operator sound pressure level measured according to the procedures specified in ISO 6394:1998 is 69 dB(A) for the cab offered by Caterpillar, when properly installed, maintained and tested with the doors and windows closed.
- Hearing protection may be needed when operating with an open operator station and cab (when not properly maintained or doors/windows open) for extended periods or in noisy environments.
- The European Union 2000/14/EC labeled spectator sound power level is 106 dB(A).

Hydraulic System

Implement System

Pump Output 270 l/min

Relief lift valve setting 275 bar

Relief tilt valve setting 302 bar

Hydraulic Cycle Times seconds

Raise 6.2

Dump 2.1

Lower, Empty, Float Down 2.8

Total 11.1

- Implement system, variable axial piston pump (rated at 2100 rpm and 69 bar)
- Cycle times with rated payload

Service Refill Capacities

Fuel Tank 338 Liters

Cooling System 42

Crankcase 30

Transmission 34

Differentials and Final Drives

Front 36

Rear 36

Hydraulic Tank 110

ROPS/FOPS

- Caterpillar cab with integrated Rollover Protective Structure (ROPS) is standard in Europe.
- Rollover Protective Structure ROPS meets ISO 3471:1994 criteria.
- Falling Objects Protective Structure (FOPS) meets ISO 3449:1992 Level II criteria.

Brakes

Meet ISO 3450:1996 standard.

Transmission

Forward km/h

1 7

2 13

3 23

4 40

Reverse

1 8

2 14

3 25

4 44

- Maximum travel speeds (23.5–25 tires)

Tires

23.5 R 25, L-3 (XHA MX)

23.5 R 25, L-5 (XMINE MX)

23.5 R 25, L-2 (XTLA MX)

23.5 R 25, L-3 (VMT BS)

In certain applications (such as load and carry) the loader's productive capabilities might exceed the tires' tonnes-km/h capabilities. Caterpillar recommends that you consult a tire supplier to evaluate all conditions before selecting a tire model. The 23.5-25 size range and other special tires are available on request.

Dimensions

All dimensions are approximate

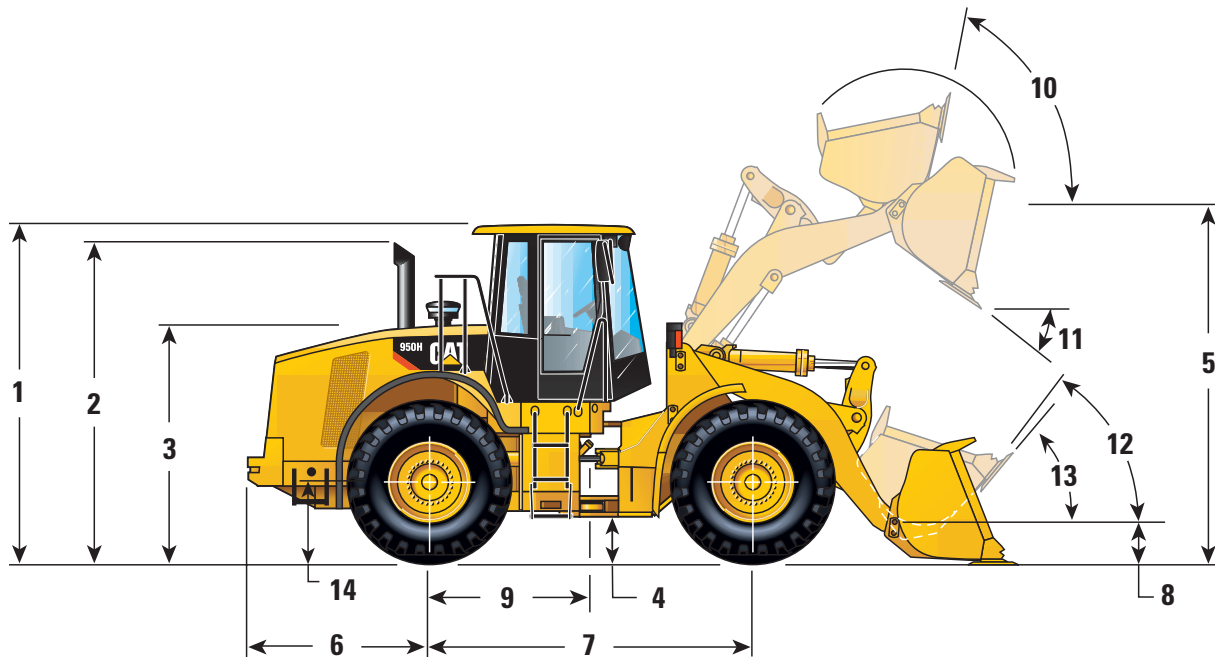

	mm				
1	Height to top of ROPS	3452	10	Rack back at maximum lift	59°
2	Height to top of exhaust pipe	3368	11	Dump angle at maximum lift	45°
3	Height to top of hood	2462	12	Rack back at carry	45°
4	Ground clearance with 23.5 R 25, L-3	412	13	Rack back at ground	37.5°
5	Bucket hinge pin height (B-pin)	3991	14	Height to center line of axle	748 mm
6	Center line of rear axle to edge of counterweight	1955			
7	Wheelbase	3350			
8	Bucket hinge pin height at carry (B-pin)	455			
9	Center line of rear axle to hitch	1675			

Tire Specifications

	Width over tires	Change in vertical dimensions	Change in operating weight	Change in static tipping load
	mm	mm	kg	kg
23.5 R 25, L-3 (XHA MX)	2784	0	0	0
23.5 R 25, L-2 (VSW BS)	2862	+6	+20	+14
23.5 R 25, L-2 (VUTD2A BS)	2866	+10	-41	-29
23.5 R 25, L-2 (XTLA MX)	2801	+7	-112	-79
23.5-25, L-2 (SGGL FS)	2834	+14	-472	-335
23.5 R 25, L-3 (VMT BS)	2851	+3	+124	+88
750/65 R 25, L-3 (XLD MX)	2879	+7	+460	+326
23.5 R 25, L-5 (XMINE MX)	2807	+26	+872	+619

Operation Specifications

		Universal Buckets							
		Bolt-on Cutting Edge	Tips and Segments	Bolt-on Cutting Edge	Tips and Segments	Bolt-on Cutting Edge	Tips and Segments	Bolt-on Cutting Edge	Tips and Segments
Rated bucket capacity	m ³	4*	4*	3.5	3.5	3.3	3.3	3.1	3.1
Struck capacity	m ³	3.49	3.49	3.00	3.00	2.83	2.83	2.66	2.66
Width	mm	2927	2994	2927	2994	2927	2994	2927	2994
Dump clearance at full lift and 45° discharge ⁴	mm	2711	2583	2800	2671	2835	2706	2870	2742
Reach at full lift and 45° discharge ⁴	mm	1282	1381	1194	1293	1158	1257	1123	1222
Reach with lift arms horizontal and bucket level ⁴	mm	2713	2874	2588	2749	2538	2699	2488	2649
Digging depth	mm	92	92	92	92	92	92	92	92
Overall length ⁴	mm	8193	8371	8068	8246	8018	8196	7968	8146
Overall height with bucket at full raise	mm	5613	5613	5479	5479	5433	5433	5388	5388
Loader turning radius with bucket in carry position	mm	7075	7153	7042	7119	7029	7106	7016	7092
Static tipping load straight ¹	kg	12 633	12 493	12 898	12 761	13 007	12 869	13 114	12 978
Static tipping load at full articulation (37°) ¹	kg	11 059	10 919	11 308	11 171	11 410	11 273	11 511	11 375
Breakout force ²	kN	137	136	152	150	158	157	166	164
Bucket weight	kg	1866	1970	1746	1850	1700	1804	1654	1758
Operating weight ¹	kg	18 618	18 722	18 498	18 602	18 452	18 556	18 406	18 510

* Light material only

¹ Static tipping load and operating weight shown are based on average machine configuration with sound suppression cab and ROPS, secondary steering, air conditioning, ride control, limited slip rear, roading fenders, autolube, front access platform, back-up alarm, 23.5 R 25, L-3, tires for Universal buckets, L-4 tires for General Excavation buckets, L-5 tires for Rock buckets, full fuel tank, coolant, lubricants, lights, directional signals, CE plates and operator.

² For buckets with adapters, tips and segments, value is measured 102 mm behind the tip of the segment, with bucket hinge pin as pivot point, in accordance with SAE J732C.

³ All buckets shown can be used on the high lift arrangement. High lift column shows changes in specifications from standard lift to high lift. Add or subtract as indicated to or from specifications given for appropriate bucket to calculate high lift specifications.

Dimensions for dump clearance, reach and overall length:

⁴ Actual dimensions taken at the tip of the Ground Engaging Tools, either the tip of the bolt-on cutting edge or the tip of the teeth, type long.

	General Excavation Buckets						Rock Buckets		High Lift ³
	Bolt-on Cutting Edge	Tips and Segments	Bolt-on Cutting Edge	Tips and Segments	Bolt-on Cutting Edge	Tips and Segments	Bolt-on Cutting Edge	Tips and Segments	
	3.1	3.1	2.9	2.9	2.7	2.7	2.9	2.9	same
	2.65	2.65	2.45	2.45	2.26	2.26	2.44	2.44	same
	2927	2994	2927	2994	2927	2994	2985	2969	
	2897	2775	2943	2823	2991	2872	2817	2642	+518
	1244	1352	1208	1318	1175	1285	1178	1328	+27
	2546	2707	2486	2647	2426	2587	2576	2806	+372
	75	75	75	75	75	75	66	66	-11
	8019	8197	7959	8137	7899	8077	8059	8304	+442
	5458	5458	5401	5401	5343	5343	5416	5416	+551
	7031	7108	7016	7092	7000	7077	7069	7130	+357
	13 229	13 093	13 650	13 211	13 473	13 339	13 580	13 450	-1570
	11 601	11 465	12 015	11 576	11 831	11 697	11 900	11 770	-1470
	156	155	166	164	175	173	150	149	-5.4
	1678	1782	1327	1731	1565	1669	1773	1870	same
	18 876	18 980	18 525	18 925	18 763	18 867	19 397	19 494	+510

Bucket Selection Guide

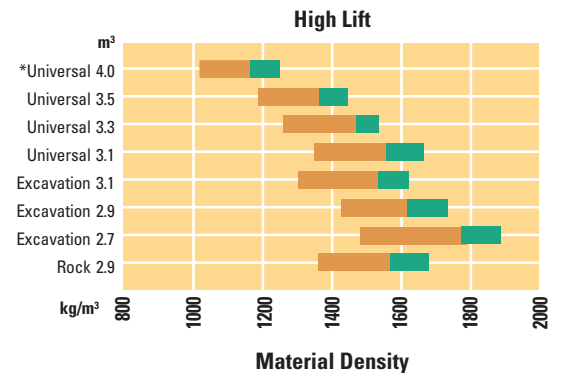
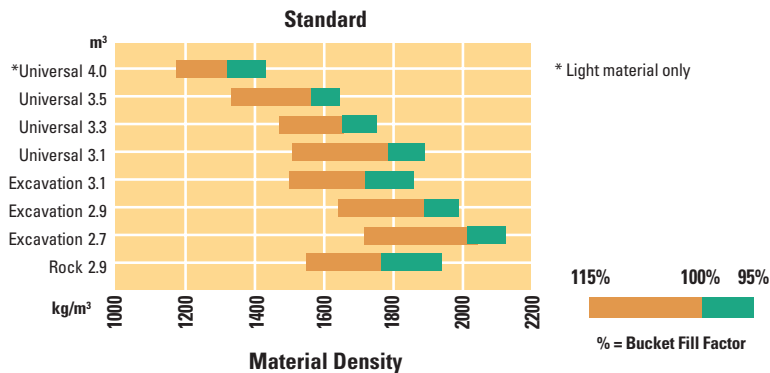

In accordance with SAE J818, these data consider the bucket load to be equal to half of the static tipping load at full turn.

Standard Equipment

Standard equipment may vary. Consult your Caterpillar dealer for specifics.

Electrical

Alternator, 80-amp brushless
Batteries, maintenance-free (2)
Battery disconnect switch
Ignition key; start/stop switch
Starter, electric, heavy-duty
Starting and charging system
(24-volt)
Working lights, halogen (6 total)

Operator Environment

Bucket/work tool function lockout
Cab, pressurized and sound-suppressed
ROPS/FOPS
Radio-ready (entertainment) includes
antenna, speakers and converter
(12-volt, 10-amp)
Caterpillar Monitoring System
Instrumentation, gauges:
Digital gear range indicator
Engine coolant temperature
Fuel level
Hydraulic oil temperature
Speedometer/tachometer
Transmission oil temperature
Instrumentation, warning indicators:
Air inlet heater
Axle oil temperature
Electrical, alternator output
Engine air filter restriction
Engine inlet air temperature
Engine oil pressure
Fuel level
Fuel pressure, high/low
Hydraulic filter bypass
Hydraulic oil level
Parking brake
Primary steering oil pressure
Service brake oil pressure
Transmission oil filter bypass

Cigar lighter (12-volt), ashtray
Coat hook (2) with straps
Controls, electrohydraulic,
lift and tilt function
Heater and defroster
Horn, electric (steering wheel/console)
Light, dome (cab)
Lunchbox, beverage holders and
personal tray
Mirrors, external
Seat, Cat Comfort (cloth) with
air suspension
Seat belt, retractable, 51 mm
Steering column, adjustable angle
(steering wheel and Command
Control) length (Command Control)
Sun visor, front
Wet-Arm wipers and washers,
front and rear
Intermittent front wipers
Window, sliding (left side)

Power Train

Brakes, full hydraulic enclosed wet-disc
with Integrated Braking System (IBS)
and brake wear indicator
Engine, Cat C7 with ACERT
technology and air to air aftercooler
Fan, radiator, electronically controlled,
hydraulically driven, temperature
sensing, on demand
Filters, fuel, primary/secondary
Filters, engine air, primary/secondary
Fuel priming pump (electric)
Fuel/water separator
Muffler, sound suppressed
Radiator, unit core
Starting aid, air inlet heater
Switch, transmission neutralizer lockout
Torque converter, free wheel stator
Transmission, automatic/manual,
planetary powershift (4F/4R)
Variable Shift Control (VSC)

Other

Automatic bucket positioner
Counterweight
Doors, service access (locking)
Ecology drains, engine, transmission
and hydraulics
Fender extensions, front and rear
Fenders, steel (front and rear)
Grill, airborne debris
Hitch, drawbar with pin
Hood, non-metallic, power tilting
Hose couplings, Caterpillar O-ring
face seal
Hoses, Caterpillar XT™
Hydraulic oil cooler
Kickout, lift and tilt, automatic (in-cab
adjustable)
Linkage, Z-bar, cast crosstube/tilt lever
Oil sampling valves (engine, transmission
and hydraulic oils)
Product Link ready
Remote diagnostic pressure taps
(steering, hydraulic, transmission
and brakes)
Service center, electrical and hydraulic
Sight gauges:
Engine coolant
Hydraulic oil
Transmission oil level
Steering, load sensing

Tires, Rims, Wheels

A tire must be selected from the
mandatory attachments section
(price list). Base machine price
includes an allowance based on
a premium radial tire.

Antifreeze

Premixed 50% concentration of
Extended Life Coolant with freeze
protection to -34°C

Optional Equipment

Optional equipment may vary. Consult your Caterpillar dealer for specifics.

Aggregate Autodig System
Air conditioner
Alarm, back-up
Autolube
Axle oil cooler, front and rear axles
Buckets, quick coupler, work tools
and Ground Engaging Tools (GET) –
see Cat dealer for details
Cat Machine Security System (MSS)
Camera package, rear vision,
includes a monitor
Cooling, high-ambient, 50°C
Differentials
Limited slip, front or rear
NO-SPIN, rear
Drain, axle ecology
Fenders, narrow
Fenders, roading
Guard, axle seal
Guard, front window,
wide or small mesh
Guard, power train
Guard, vandalism
Heater, engine coolant, 240-volt
Hydraulic arrangement, three-valve
Joystick control, two- or three-valve
Lights
directional
high intensity discharge (HID)
roading
warning beacon
work, cab-mounted

Mirrors, heated external
Mirrors, heated external, folding
Mirror, rearview (internally mounted)
Open canopy
Payload Control System
Payload Control System Printer
Platform, window cleaning
Precleaner, turbine
Precleaner, turbine/trash
Product Link
Radio, AM/FM
Receptacle, jump-start, 24-volt
Remote pressure taps (transmission,
steering, torque converter and
implement systems)
Ride Control System,
two- or three-valve
Seat, Deluxe (heated cushion, high back
extension, ride zone indicator,
operator weight shock adjustment)
Sound suppression, exterior
Starting aid, ether
Steering, Command Control System
Steering, secondary
Switch, FNR (steering wheel machines)
Special Machine Arrangements
High Lift Arrangement,
two- and three-valve
Switch FNR (steering wheel machine)
Toolbox
Window, sliding (right side)
Vandalism protection caplocks

Merchandising Arrangement 0 (not for EU regulated countries)

Wheel Loader, SW
Air conditioner
Precleaner, turbine

Merchandising Arrangement 1

Wheel Loader, SW
Conversion, CE mark
Air conditioner
Tool box

Merchandising Arrangement 2

Wheel Loader, SW
Conversion, CE mark
Air conditioner
Differential, limited slip, rear
Ride control, 2 valve

Merchandising Arrangement 3

Wheel Loader, SW
Conversion, CE mark
Air conditioner
Aggregate Autodig
Limited Slip Differential, rear
Ride control, 2 valve
Seat, Deluxe

Merchandising Arrangement 4

Wheel Loader, SW
Conversion, CE mark
Air conditioner
Hydraulics, 3 valve
Ride control, 3 valve

Logging Arrangement

Hydraulics, 3 valve
Ride control
Additional counterweight

Other Special Arrangements

High Lift Arm, provides +518 mm
dump clearance
Access package (15° inclined ladder
and front access platform)

950H Wheel Loader

For more complete information on Cat products, dealer services, and industry solutions, visit us on the web at www.cat.com

Materials and specifications are subject to change without notice. Featured machines in photos may include additional equipment. See your Caterpillar dealer for available options.

© 2007 Caterpillar -- All rights reserved

CAT, CATERPILLAR, their respective logos, "Caterpillar Yellow" and the POWER EDGE trade dress as well as corporate and product identity used herein, are trademarks of Caterpillar and may not be used without permission.

HEHL3373-1 (03/2007) hr

CATERPILLAR[®]