

963K

Track Loader



Engine

Engine Model	Cat® C7.1 ACERT™	
Engine Power (Maximum) – ISO 14396	165 kW	221 hp
Engine Power (Maximum) – ISO 14396 (DIN)		224 hp
Net Power (Rated) – ISO 9249/SAE J1349	144 kW	193 hp
Net Power (Rated) – ISO 9249/SAE J1349 (DIN)		196 hp

Buckets

Capacity – General Purpose	2.45 m ³	3.2 yd ³
Capacity – Performance Series	2.8 m ³	3.66 yd ³
Capacity – Multi-Purpose	1.9 m ³	2.48 yd ³

Weights

Operating Weight	20 308 kg	44,771 lb
------------------	-----------	-----------

963K Features

Fuel Efficiency

A more fuel efficient Cat C7.1 ACERT engine and Eco Mode combine to give you a 10-30 percent reduction in fuel use.*

Performance

Smarter powertrain management gives you power when you need it and improved implement and steering response.*

Ease of Operation

Cab updates offer added comfort and convenience for operators. New handles and steps make access/egress even easier from the front or the back of the tracks.

Technology

Remote monitoring with Product Link™/ VisionLink® helps you manage your fleet more effectively and profitably.

*Compared to the 963D.



Contents

Efficiency and Performance	4
Operator Environment.....	6
Emissions Technology.....	7
Equipped for the Job	8
Structures.....	9
Undercarriage	9
Special Arrangements	10
Sustainability	11
Safety	11
Serviceability and Customer Support.....	12
Specifications.....	14
Standard Equipment.....	18
Optional Equipment.....	19



A Cat Track Loader is one of the most versatile machines on the job site. Save money and transport time with one rugged machine capable of a multitude of tasks like land clearing, digging, backfilling, grading, truck loading, carrying, spreading materials, slope work, and more. Steel tracks on a crawler loader offer reduced ground pressure and better traction so you can often start the job earlier and work longer than other machines in soft underfoot conditions. The new 963K brings you all of this value, plus improved performance, 10-30 percent better fuel efficiency and additional comfort and safety features for the operator. The 963K meets U.S. EPA Tier 4 Final/EU Stage IV/ Korea Tier 4 Final emission standards.



Engine

A Cat C7.1 ACERT engine gives you the power and reliability you need to get the job done. The engine is equipped with a twin turbo, providing faster machine response under load.

Fuel Efficiency/Eco Mode

The more efficient engine and an **Eco Mode** combine to deliver a 10-30 percent reduction in fuel consumption compared to the 963D. Eco Mode automatically reduces engine speed, but maintains selected ground speed under lighter loads. Efficient use of Diesel Exhaust Fluid (DEF) – typically 2.5-3 percent of fuel consumption – provides excellent overall fluid efficiency.

Hydrostatic Drive

A new Electronic Control Module gives you smarter power train management, resulting in smoother implement/steering response and improved steering performance over the previous model. Power reaches the ground more efficiently based on the demands of the application, giving you fast acceleration and shorter cycle times. The electronically controlled Hystat drive uses variable displacement pumps and drive motors to power each track independently, delivering fast acceleration and infinitely variable speed. The operator can command smooth machine turns and counterrotation.

Cooling System

The single unit cooling system incorporates the radiator, air-to-air aftercooler, oil cooler and fan installation. The cooling module is located at the rear of the loader, away from dust and debris stirred up by the bucket while the machine is working. The radiator has 6.5 fins per inch to help reduce plugging. A simple, side-by-side design reduces debris and makes cleaning easier. The fold-down design gives you easy access.

A hydraulic demand fan reduces speed in cooler conditions to conserve power, save fuel and decrease sound levels. An optional reversing fan is available for high debris conditions.



Efficiency and Performance

Built to get the job done



Load-Sensing Hydraulics

Field-proven system senses the load and continuously adjusts hydraulic power to maximize your efficiency. Operators have precise control and the power needed for simultaneous lift, tilt and travel.

Position Sensing Cylinders

Position Sensing Cylinders allow the operator to set lift and tilt kickouts to match the application without leaving the cab. Linkage can be automatically set to specific positions for increased productivity. Advanced automatic features help make start/stop motions smoother, reducing vibration in the cab.

Automatic Kickouts

Standard programmable automatic kickouts provide flexibility and productivity for precise load and dump target heights. Tilt and lift kickouts are easily set by positioning the bucket or attachment and pressing a button on the right-hand control panel in the cab.





Updated cab gives operators added comforts like adjustable armrests and controls, improved air conditioning system and a heated/ventilated seat option. A new LCD operator interface makes it simple to customize machine performance features and to view machine operating and service information.

Excellent visibility to the bucket and all around the machine helps operators work more confidently, and an optional rearview camera enhances safety. Reduced engine noise* makes the environment quieter for the operator and others around the worksite.

Cab-mounted heating/ventilation/air conditioning (HVAC) system gives you more cooling capability, and removes the condenser from under the hood for reduced heat and easier service.

**Compared to the 963D.*

Operator Environment

Comfort and productivity



Implement and Steering Controls

- Electro-Hydraulic Implement Controls provide the operator with responsive, smooth and precise control of bucket and lift arms.
- Choose from either joystick or two-lever implement controls to match operator preference or application.
- Speed/steering controls are available as either a joystick or as V-lever and foot pedals.
- A variable throttle control dial lets you use preset engine speeds, customized for operator preference.
- Selectable Electro-Hydraulic maps allow you to set implement response – fine, normal, coarse – to match operator preference or application.
- Hydrostatic Drive system provides quick machine travel speed, on-the-go directional changes and counterrotation.



Emissions Technology

Proven, integrated solutions

Emissions reduction technology on the 963K is designed to be transparent, with no action required from the operator. Regeneration runs automatically in the background while you work.

Aftertreatment Technologies

With millions of working hours on hundreds of thousands of units since the Tier 4 Interim/Stage IIIB product introductions, you can be confident in the quality and value of your Tier 4 Final/Stage IV/Korea Tier 4 Final investment. To meet the reduction in NO_x emissions required by the latest emission standards, Caterpillar engineers added Selective Catalytic Reduction (SCR) to the already proven aftertreatment solution.



Diesel Exhaust Fluid

Selective Catalytic Reduction utilizes Diesel Exhaust Fluid (DEF), which can be conveniently refilled from ground level when you refuel. The system is designed to use one tank of DEF for each tank of fuel (1:1 DEF fill ratio). A gauge on the dash shows your fluid level. Across a variety of applications, the 963K typically has used DEF at a rate of 2.5-3 percent of fuel consumption.

When the machine is turned off, a pump will automatically purge the DEF lines. A symbol on the dash and a light/symbol in the engine compartment indicate when the purge is complete and that it is safe to turn off the electrical disconnect. If the engine/aftertreatment temperatures are high, a Delayed Engine Shutdown will activate automatically to cool the machine and then purge the lines. For complete aftertreatment information, please refer to your machine's Operation and Maintenance Manual.

Equipped for the Job

Optimize your machine

Buckets

A choice of buckets help you optimize your machine for the work you do. The General Purpose bucket is designed for excellent loadability and long life in applications like hard bank excavating, stripping and stockpile loading. The Multipurpose bucket is designed for versatility, and is ideal for a variety of tasks like loading, stripping, clearing, bulldozing, picking up debris and fine grading. The bucket clamps hydraulically to grip or handle other tough-to-grasp materials.

A new optional Performance Series bucket contributes to your productivity by moving 5-10 percent more material per hour. And for special applications, Caterpillar also offers buckets optimized for applications like waste/landfill and ship hold work.

K Series™ Bucket Tooth Tips

The K Series tooth system stays sharp, holds tight and allows for simple changes. The lower-profile shape maintains optimal sharpness, penetration and digging ability throughout the tip life.

Quick Coupler Ready

Fusion™ Quick Coupler option gives you more versatility by allowing easy use of forks, buckets, etc. from wheel loaders and other Fusion compatible machines.

Ripper

The multi shank ripper adds extra versatility and force to expand the machine's range of applications. The ripper beam has three pockets for holding ripper shanks, and its design allows the machine to rip frozen ground, asphalt and even hard soils or rock. Long shanks deliver more work per pass making the machine more productive.



Structures

Tough and durable

Caterpillar designs track loader structures to handle the impact and twisting forces encountered in the most demanding applications. Slab rails are reinforced with forgings and castings at points of high stress to give you durability and long life. The integrated main frame and loader tower provide a solid mount for durable lift arms, lift cylinders and tilt cylinders. Robust structures throughout the machine are not only designed for term value, but also to support multiple rebuilds.



Undercarriage

Engineered for performance



An oscillating undercarriage decreases ground shock to the machine, giving you increased stability and a smoother ride. Choose Sealed and Lubricated Track undercarriage for aggressive applications like land clearing, side-slopes or rocky terrain. Or, choose SystemOne™ undercarriage that is designed to work and wear as a system for longer life and lower costs in many applications. A choice of track shoe designs and widths help you further optimize your machine for performance and longer life.

Special Arrangements

Purpose-built for performance



963K Waste Handler

Designed and built from the frame up to take on the unique challenges of landfill and transfer station work.

- Specialized guarding, striker bars and seals help protect the machine from impact and airborne debris.
- Final Drive guarding helps prevent wrapping and damage.
- Cooling system is designed for high debris environments, with easy access for cleanout.
- Specialized air handling features help deliver cleaner air to the machine and to the cab.
- Landfill buckets and track options help you optimize your waste handler for the job.

963K SH Ship Hold/Port Handling

Maneuverability, ease of operation and reach make a track loader the ideal machine for quickly removing materials from ship holds.

- Sweep down walls and handle a wide variety of materials.
- Specialized sealing, guards and bumpers help protect key components.
- Added lighting packages help illuminate the work area.
- Specialized implements, like coal buckets and trim blades, help you equip the machine for optimal performance.
- Fusion Quick Coupler option gives you more versatility by allowing easy use of forks, buckets, etc. from wheel loaders and other Fusion compatible machines.
- Lift eyes on the frame and undercarriage are widely spaced for stability during lifting.

Custom Products/Value Packages

Caterpillar offers a variety of custom product options for track loaders, such as wide gauge machines and special guarding packages. Please talk to your Cat dealer about your specific job site needs.

Sustainability

Built for the next generation

- Meets Tier 4 Final/Stage IV/Korea Tier 4 Final emission standards.
- A more fuel efficient engine and Eco Mode combine to give you 10-30 percent better fuel efficiency.*
- Efficient use of Diesel Exhaust Fluid (DEF) gives you excellent overall fluid efficiency.
- Features like the optional Performance Series Bucket and the demand fan help you get more work done with less fuel.
- Quieter engine reduces noise for the operator and others around the job site.
- Major components are built to be rebuilt, eliminating waste and saving you money by giving your loader a second – and even third – life.

**Compared to the 963D.*



Safety

Designed with protection in mind



- New handles and steps help operators climb on and off the machine more easily, from the front or the back of the tracks.
- Excellent visibility to the bucket and all around the machine helps operators work more confidently.
- Rear vision camera is available to enhance visibility behind the machine.
- New seat belt indicator gives an alarm and registers fault code through Product Link if the operator fails to buckle up, enhancing job site safety.
- Improved ergonomics, a quieter engine and reduced effort controls help lessen fatigue so operators are better able to remain fresh and focused.



Serviceability and Customer Support

When uptime counts

Ease of Service

The 963K is designed to help you take care of routine maintenance and get back to work. Grouped service points are located behind large access doors, and daily grease points are in easy reach at ground level. The tilt cab allows easy access to drive train and hydraulic systems. The cooling system can be accessed from the engine compartment and features a fold-down fan for easy clean-out. A handy bracket at the rear of the machine holds a shovel to help you clean the undercarriage.

The Diesel Particulate Filter in the Clean Emissions Module is designed to work for the life of the engine without needing to clean or replace the filter.

The service mode in the operator display shows you hydrostatic and implement pressure for easier troubleshooting and servicing.

Product Link*/VisionLink

Product Link is deeply integrated into your machine. Easy access to timely information like machine location, hours and event codes via the online VisionLink user interface can help you manage your fleet and reduce operating costs.

**Product Link not available in all areas. Please consult your Cat dealer for details.*



Cat EMSolutions (Equipment Management Solutions)

EMSolutions lets you take control of your fleet with a solution specific to your equipment management needs. Comprehensive, technology-enabled equipment management – combined with the knowledge and expertise of your Cat dealer – can provide ways to help you achieve gains that go straight to your bottom line.

- Improve availability
- Reduce owning and operating costs
- Streamline maintenance practices
- Maximize equipment life
- Increase resale value

Consisting of five levels of support, from remote access to equipment data to complete, proactive management of your fleet, EMSolutions allows you to choose the amount of support that's right for you.



Renowned Cat Dealer Support

Knowledgeable Cat dealers have a global reputation for providing outstanding sales and service. Maximize your equipment investment with a Customer Support Agreement tailored to meet your business needs. Take advantage of preventive maintenance programs like Custom Track Service, Scheduled Oil Sampling (S-O-SSM) analysis, and guaranteed maintenance contracts. Cat dealers can even help you with operator training to help boost your profits.

When you need repairs, Cat dealers and our unmatched Caterpillar distribution network excel at getting you the right parts you need quickly.

Your Cat dealer can also help you maximize your equipment investment with services like Cat Reman parts and Cat Certified Rebuilds. Remanufactured parts offer you the same warranty and reliability as new parts at a fraction of the cost. A Certified Rebuild gives a “second life” for your machine, incorporating the latest engineering updates so you end up with a like-new track loader and a new machine warranty. Caterpillar strives to provide customers the lowest owning and operating costs over the life of their machine.

963K Track Loader Specifications

Engine

Engine Model	Cat C7.1 ACERT	
Emissions	Tier 4 Final/Stage IV/ Korea Tier 4 Final	
Engine Power (Maximum)		
ISO 14396	165 kW	221 hp
ISO 14396 (DIN)	224 hp	
Net Power (Rated)		
ISO 9249/SAE J1349	144 kW	193 hp
ISO 9249/SAE J1349 (DIN)	196 hp	
Bore	105 mm	4.13 in
Stroke	135 mm	5.31 in
Displacement	7.01 L	427.8 in ³

- Engine power ratings occur at 1,800 rpm.
- All non road Tier 4 Interim and Final, Stage IIIB and IV and Korea Tier 4 Final diesel engines are required to use only Ultra Low Sulfur Diesel (ULSD) fuels containing 15 ppm (mg/kg) sulfur or less. Biodiesel blends up to B20 (20% blend by volume) are acceptable when blended with 15 ppm (mg/kg) sulfur or less ULSD. B20 should meet ASTM D7467 specification (biodiesel blend stock should meet Cat biodiesel spec, ASTM D6751 or EN 14214). Cat DEO-ULS™ or oils that meet the Cat ECF-3, API CJ-4, and ACEA E9 specification are required. Consult your OMM for further machine specific fuel recommendations.
- Diesel Exhaust Fluid (DEF) used in Cat Selective Catalytic Reduction (SCR) systems must meet the requirements outlined in the International Organization for Standardization (ISO) standard 22241.

Undercarriage

Track Shoe Type	Double Grouser	
Track Shoe Width – Standard	550 mm	21.6 in
Track Shoe Width – Optional	450 mm	17.7 in
Track Rollers – Each Side	7	
Number of Shoes – Each Side	38	
Track on Ground	2542 mm	100 in
Ground Contact Area – Standard Shoe	2.8 m ²	4,340 in ²
Ground Contact Area – Optional Shoe	2.3 m ²	3,565 in ²
Ground Pressure – Standard Shoe	70.9 kPa	10.3 psi
Ground Pressure – Optional Shoe	85.5 kPa	12.4 psi
Grouser Height – Double Grouser	42 mm	1.65 in
Track Gauge	1850 mm	72.8 in

Drive System

Track Motor	Two, variable displacement, bent axis motors
Drive System	Hydrostatic drive with infinite machine speeds to 10.0 km/h (6.2 mph)
Drive Pump	Two, variable displacement, slipper-type axial piston pumps
Track Motor	Two, variable displacement, bent axis motors
Relief Valve Setting	47 500 kPa 6,890 psi

Service Refill Capacities

Fuel Tank	320 L	84.5 gal
Cooling System	32 L	8.45 gal
Crankcase (with filter)	16.5 L	4.4 gal
Final Drives (each)	15 L	4 gal
Hydraulic Tank	90 L	23.7 gal
Pivot Shaft	1.8 L	0.5 gal
DEF Tank	16 L	4.22 gal

Weights

Operating Weight	20 308 kg	44,771 lb
------------------	-----------	-----------

Buckets

Capacity – General Purpose	2.45 m ³	3.2 yd ³
Capacity – Performance Series	2.8 m ³	3.66 yd ³
Capacity – Multi-Purpose	1.9 m ³	2.48 yd ³
Bucket Width – General Purpose	2612 mm	102.8 in
Bucket Width – Performance Series	2712 mm	106.8 in
Bucket Width – Multi-Purpose	2575 mm	101.3 in

Bucket Cycle Times

Lift	5.5 seconds
Power Down	3.7 seconds
Float Down	2.0 seconds
Dump at Maximum Height (from full rackback)	1.3 seconds
Rackback at Maximum Height (from full dump)	1.4 seconds

Ripper Specifications

Type	Radial	
Number of Pockets	3	
Overall Width/Beam	1950 mm	76.7 in
Shank Cross Section	58.5 mm × 138 mm	50 in × 5.4 in
Ground Clearance	595 mm	23.4 in
Penetration	295 mm	11.6 in
Ripping Width	1836 mm	72.3 in
Cylinders – Bore	114.3 mm	4.5 in
Cylinders – Stroke	289 mm	11.3 in
Added Machine Length with Ripper in Transport Position	610 mm	24.0 in

Hydraulic System – Equipment

Type	Closed center, load sensing piston	
Output	230 L/min	60.8 gal/min
Main Relief Valve Setting	27 500 kPa	3,989 psi

Standards

ROPS/FOPS

Brakes

Cab

- ROPS (Rollover Protective Structure) offered by Caterpillar for the machine meets ROPS criteria SAE J1040 MAY94, ISO 3471:1994 DLV criteria SAE J397B, ISO 3164:1995.
- FOPS (Falling Object Protective Structure) meets SAE J/ISO 3449 APR98 Level II, ISO 3449:1992 Level II DLV criteria SAE J397B, ISO 3164:1995.
- Brakes meet SAE J/ISO 10265 MAR99 ISO 10265:1998.
- The declared dynamic operator sound pressure level is 73 dB(A) when “ISO 6396:2008” is used to measure the value for an enclosed cab. The measurement was conducted at the maximum engine cooling fan speed. The sound level may vary at different engine cooling fan speeds. The cab was properly installed and maintained. The measurement was conducted with the cab doors and the cab windows closed.
- Hearing protection is recommended when operating with an open operator station and cab (when not properly maintained or doors/windows open) for extended periods or in noisy environment.
- The declared exterior sound power level is 108 dB(A) when the value is measured according to the dynamic test procedures and the conditions that are specified in “ISO 6395:2008”. The measurement was conducted at the maximum engine cooling fan speed. The sound level may vary at different engine cooling fan speeds.
- The labeled sound power level is 111 dB(A) measured according to the test procedure and conditions specified in 2000/14/EC.

963K Track Loader Specifications

Dimensions

All dimensions are approximate.

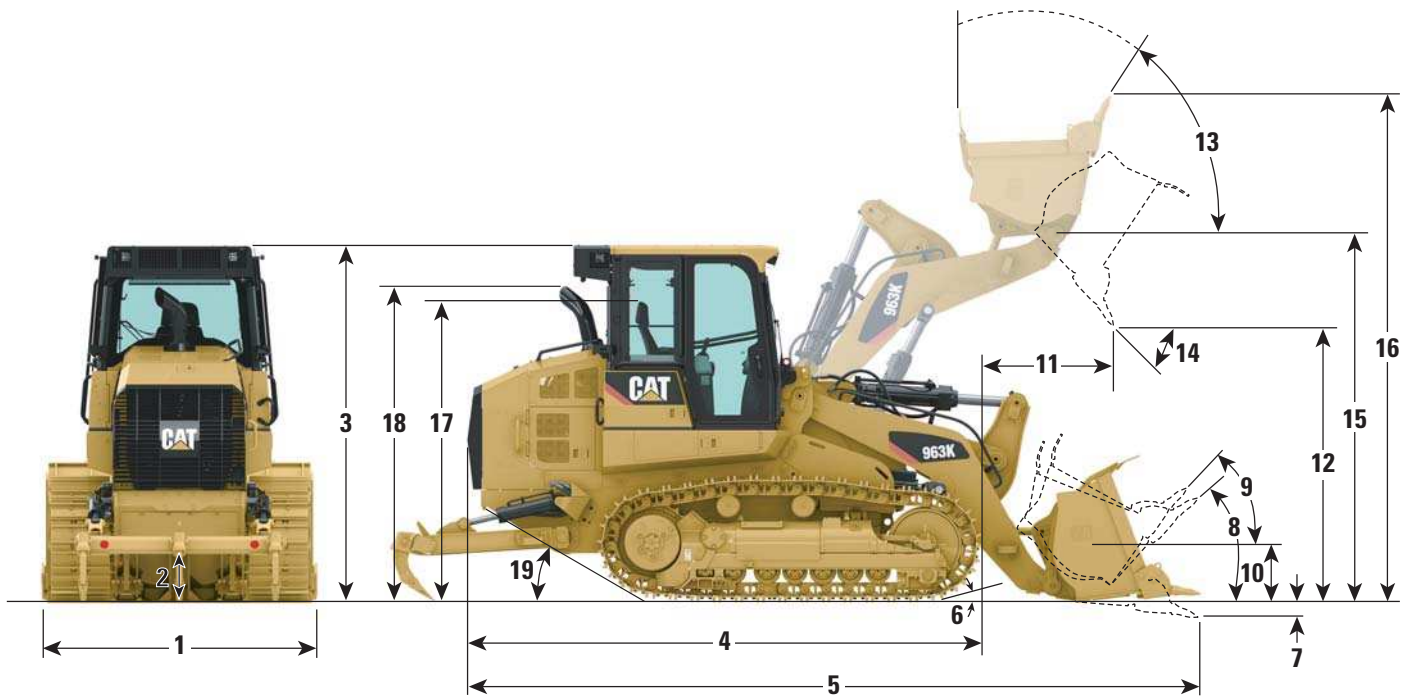

1 Overall Machine Width without Bucket:		
With Standard Tracks – 550 mm (21.6 in) Shoes	2400 mm	94.5 in
With Narrow Tracks – 450 mm (17.7 in) Shoes	2300 mm	90.5 in
2 Ground Clearance	471 mm	18.5 in
3 Machine Height to Top of Cab	3325 mm	130.9 in
4 Length to Front of Track	4943 mm	194.6 in
5 Overall Machine Length*	7001 mm	275.6 in
6 Carry Position Approach Angle		15°
7 Digging Depth*	138 mm	5.4 in
8 Maximum Rollback at Ground		43°
9 Maximum Rollback at Carry Position		50°
10 Bucket Height in Carry Position	457 mm	18 in
11 Reach at Full Lift Height and 45° Dump*	1373 mm	54 in
12 Clearance at Full Lift Height and 45° Dump*	2915 mm	114.8 in
13 Maximum Rollback, Fully Raised		52°
14 Maximum Dump, Fully Raised		53°
Grading Angle		63°
15 Height to Bucket Hinge Pin	3940 mm	155.1 in
16 Overall Machine Height, Bucket Fully Raised	5402 mm	212.7 in
17 Height to Top of Seat with Headrest	2808 mm	110.6 in
18 Height to Top of Stack	2940 mm	115.7 in
19 Ramp Angle		29°

* With general purpose bucket and extra duty teeth.

Dimensions vary with bucket. Refer to Operating Specifications chart.

963K Track Loader Specifications

Operating Specifications

		General Purpose Bucket			Multi Purpose Bucket			Flush Mounted Teeth	Performance Series Bucket
		None	Long Teeth & Segments	Bolt-on Edge	None	Long Teeth & Segments	Bolt-on Edge	Long Teeth	Long Teeth
Attachments on Bucket Cutting Edge									
Bucket Weight	kg lb	1508 3,324.5	1866 4,113.8	1721 3,794.1	1942 4,281.3	2236 4,929.5	2155 4,750.9	1619 3,569.2	1951 4,301.1
Rated Load Nominal Heaped§	kg lb	3958 8,721.4	4214 9,290.2	4214 9,290.2	3216 7,090	3388 7,469.2	3440 7,583.8	4214 9,290.2	4712 10,387
Rated Capacity Nominal Heaped	m ³ yd ³	2.3 3.0	2.45 3.2	2.45 3.2	1.9 2.4	2.0 2.6	2.0 2.6	2.45 3.2	2.8 3.66
Struck Capacity	m ³ yd ³	2.0 2.61	2.14 2.79	2.14 2.79	1.6 2.09	1.7 2.22	1.7 2.22	2.0 2.61	2.5 3.27
Bucket Width Overall*#	mm in	2508 98.7	2612 102.8	2539 99.9	2482 97.7	2575 101.3	2515 99	2583 101.6	2712 106.8
Teeth		none	***	none	none	***	none	***	***
Dimensions and Weights									
Overall Height	mm in	3325 130.9	3325 130.9	3325 130.9	3325 130.9	3325 130.9	3325 130.9	3325 130.9	3325 130.9
Overall Operating Height*	mm in	5402 212.6	5402 212.6	5402 212.6	5308 208.9	5308 208.9	5308 208.9	5402 212.6	5402 212.6
Clearance at 45° Dump Maximum Lift*	mm in	3155 124.2	2915 114.7	3068 120.7	3000 118.1	2772 109.1	2909 114.5	2951 116.1	2840 111.8
Reach at 45° Dump Maximum Lift*	mm in	1160 45.7	1373 54.1	1215 47.8	1079 42.5	1253 49.3	1119 44	1397 55	1298 51.1
Reach at 45° Dump 2133 mm (84 in) Clearance*	mm in	1784 70.2	1899 74.8	1806 71.1	1598 62.9	1650 65	1607 63.3	1940 76.4	1824 71.8
Bottom Dump Clearance at 45° Dump Maximum Lift	mm in	— —	— —	— —	3450 135.8	3450 135.8	3450 135.8	— —	— —
Bottom Dump Reach at 45° Dump Maximum Lift	mm in	— —	— —	— —	627 24.7	627 24.7	627 24.7	— —	— —
Reach with Lift Arm Horizontal and Bucket Level	mm in	2289 90.1	2604 102.5	2386 93.9	2346 92.4	2622 103.2	2447 96.4	2601 102.4	2604 102.5
Overall Length – Bucket Level on Ground*	mm in	6644 261.6	7001 275.6	6766 266.4	6758 266.1	7073 278.5	6880 270.9	6967 274.3	7107 279.8
Digging Depth*	mm in	80 3.1	138 5.4	115 4.5	161 6.3	209 8.2	191 7.5	95 3.7	138 5.4
Full Dump at Maximum Lift*	deg	53	53	53	43	43	43	53	53
Carry Height*	mm in	457 18	457 18	457 18	540 21.6	540 21.6	540 21.6	457 18	457 18
Rackback at Carry*	deg	50	50	50	52	52	52	50	50
Rackback at Ground*	deg	43	43	43	45	45	45	43	43
Grading Angle Maximum*	deg	63	63	63	63	63	63	63	63
Static Tipping Load Minimum*##	kg lb	14 969 33,001	14 462 31,883.1	14 685 32,375	14 487 31,938.3	14 124 31,138	14 208 31,323.3	14 815 32,661.5	14 377 31,696
Breakout with Tilt Cylinders Level at Ground*	N lbf	208 658 46,908	203 868 45,831	206 184 46,352	193 265 43,447	189 538 42,609	190 769 42,886	207 438 46,634	185 273 41,651
Lift Capacity to Full Lift – Bucket Racked*	kg lb	8803 19,407	8479 18,693	8609 18,979.57	8382 18,479	8152 17,972	8203 18,084.5	8703 19,186.8	8394 18,505
Lift Capacity at Ground Line – Bucket Racked*	kg lb	18 574 40,948.6	18 655 41,127	19 031 41,956	18 559 40,915.5	17 888 39,436.2	18 082 39,863.9	19 300 42,549	18 570 40,940
Shipping Weight without Bucket**	kg lb	18 418 40,605	18 418 40,605	18 418 40,605	18 473 40,726	18 473 40,726	18 473 40,726	18 418 40,605	18 418 40,605
Operating Weight with Bucket##	kg lb	20 308 44,771	20 668 45,565	20 509 45,215	20 786 45,825	21 051 46,410	20 987 46,268	20 408 44,992	20 753 45,753

* SAE J732 JUN92.

** With 10% fuel. All other fluid compartments full. No operator, no bucket pins.

*** 8 bolt-on with replaceable tips.

Width at cutting edge.

Full fuel, 75 kg (165 lb) operator, standard machine.

§ Calculation based on 1720 kg/m³ (2,900 lb/yd³) of loose dirt.

Standard Equipment

Standard equipment may vary. Consult your Cat dealer for details.

POWER TRAIN

- Cat C7.1 ACERT diesel engine
- Tier 4 Final/Stage IV/Korea Tier 4 Final certified engine
- Twin turbocharged with ATAAC
- Modular cooling system for engine air intake, oil and water
- Fan radiator, electronically controlled, hydraulically driven, temperature sensing, on demand
- Electro Hydrostatic Control (EHC) for transmission with travel and work modes
- Electric fuel pump
- Water separator
- Air cleaner dry-type, axial seal with integral precleaner and dust ejection system, electronic filter condition indicator
- Engine mounted aftertreatment
- Muffler, under hood
- Starting aid, glow plug
- Cat extended life coolant

UNDERCARRIAGE

- Cat Enhanced Sealed and Lubricated Track (ESALT) tracks
- Track guiding guards, end section
- Track adjuster, hydraulic
- Sprocket rims, with replaceable bolt-on Tough Steel segments
- Guards, sprocket
- Seven track rollers per side, with two upper carrier rollers, lifetime lubricated
- Idlers, conventional type, lifetime lubricated
- Oscillating track roller frames

ELECTRICAL

- Alternator, 24V, heavy duty brushless
- Alarm, backup
- Horn, electric
- Two heavy duty batteries, high output, maintenance free, 1,120 CCA
- Switch, main disconnect
- Starter, electric (heavy duty, 24V)
- Four halogen lights, two facing forward, roof mounted; two facing rearward integrated into A/C unit

OPERATOR ENVIRONMENT

- Pressurized, sound suppressed, ROPS/FOPS
- Cab with tinted glass and right side sliding window
- Air conditioning and heating
- Heater/defroster with automatic temperature control
- Seat, fabric-covered, air suspended adjustable
- Electro hydraulic, seat mounted control levers with faster processing
- Seat belt, retractable, with indicator on dash
- Electronic Monitoring System with gauges for:
 - Engine coolant temperature
 - Hydraulic oil temperature
 - DEF level
 - Fuel level
- Mirror, rearview, inside, adjustable
- Radio ready – includes 24V to 12V converter, speakers, antenna and two 12V power outlets
- Coat hook
- Storage compartments under left armrest
- Document holder on right console
- Floor mat, rubber, heavy duty
- Windshield washers and wipers, multiple speed front and rear
- Durable metal roof
- Parking brake switch and “brake-on” indicator light
- Fender

OTHER STANDARD EQUIPMENT

- Sound suppression, exterior
- Z-bar loader linkage
- Load sensing variable displacement implement pump
- Implement cylinders sensors
- Operator programmable lift and tilt
- Engine enclosure with lockable doors
- Radiator core 6.5 fpi, debris resistant
- Hinged radiator guard and swing out fan
- Guards, full bottom
- Ecology drains on hydraulic oil tank
- Product Link ready
- Oil sampling valves
- Hoses, Cat XT™
- HYDO™ Advanced 10

Optional Equipment

Optional equipment may vary. Consult your Cat dealer for details.

POWER TRAIN

- Radiator fan, demand, reversing
- Air inlet, precleaner turbine

OPERATOR ENVIRONMENT

- Cab, deluxe
- Seat, cloth, air suspension, no side-to-side isolator
- Seat, cloth, air suspension, heated, side-to-side isolator
- Lights and windshield
 - Lights, additional guarded
 - Windshield protection
- Radio, AM/FM/AUX/USB/Bluetooth
- Easy access package
- Service package, extended

TRANSMISSION

- Transmission control, V-lever
- Transmission control, joystick

UNDERCARRIAGE

- Guard, idler
- Guard, idler, ship hold
- Track Groups (38 sections)
 - Track Groups (SystemOne)
 - Track, 550 mm (22 in), double grouser, standard
 - Track, 450 mm (18 in), double grouser, narrow
 - Track Groups (ESALT)
 - Track, 450 mm (18 in), double grouser, narrow, ESALT
 - Track, 550 mm (22 in), double grouser, ESALT
 - Track, 550 mm (22 in), double grouser, center hole, ESALT
 - Track, 450 mm (18 in), double grouser, center hole, ESALT
 - Track, 450 mm (18 in), single grouser, center hole, extreme service, ESALT
 - Track, 550 mm (22 in), single grouser, center hole, extreme service, ESALT
 - Track, 550 mm (22 in), single grouser, extreme service, ESALT
 - Track Groups (Heavy Duty)
 - Track, 800 mm (31 in), double grouser, heavy duty

HYDRAULICS

- Hydraulic oil, biodegradable
- Hydraulics Packages
 - Hydraulic two valve, two levers
 - Hydraulic three valve, rear, two levers
 - Hydraulic two valve, joystick
 - Hydraulic three valve rear, joystick
 - Hydraulic three valve front, joystick
 - Hydraulic four valve front and rear, joystick

GUARDS

- Guard, lift cylinders
- Guard, tilt cylinder
- Guard, final drive abrasion 2-piece
- Guard, final drive abrasion 3-piece
- Guard, full length track roller

FUEL SYSTEMS

- Tank, fuel, fast fill
- Tank, fuel, refueling pump

LINE GROUPS

- Lines, implement, standard
- Lines, implement, Quick Coupler
- Quick Coupler Ready

MAINTENANCE AND RELATED ATTACHMENTS

- Sediment pump, fuel tank
- Oil change system, high speed

OTHER ATTACHMENTS

- Bucket Packages
 - General Purpose, 2.5 m³ (3.25 yd³), package
 - General Purpose, 2.5 m³ (3.25 yd³), full edge
 - General Purpose, 2.3 m³ (3.0 yd³), flush pack
 - General Purpose, 2.8 m³ (3.66 yd³), Performance Series
 - General Purpose, 2.5 m³ (3.25 yd³), heavy duty
 - Landfill, 3.1 m³ (4.1 yd³), heavy duty
 - Multi-Purpose, 2.7 m³ (3.5 yd³), landfill, heavy duty
 - Multi-Purpose, 1.9 m³ (2.5 yd³), package
 - Multi-Purpose, 1.9 m³ (2.5 yd³), heavy duty package
- Ripper, multi-shank
- Hitch, ripper
- Striker bars, rear
- Counterweight, light, 325 kg (716 lb)
- Counterweight, additional, 305 kg (672 lb)
- Grade Control, receiver mast

STARTERS, BATTERIES AND ALTERNATORS

- Cold weather, 120V
- Antifreeze –50° C (–58° F)

ELECTRICAL

- Beacon, rotating

SPECIAL ARRANGEMENTS

- Construction Package – SystemOne
- Construction Package – Enhanced Sealed and Lubricated Track
- Waste Package – Enhanced Sealed and Lubricated Track
- Waste Package – Extreme Service, Enhanced Sealed and Lubricated Track
- Ship Hold Package – Enhanced Sealed and Lubricated Track
- LGP Package – Heavy Duty

TECHNOLOGY

- Product Link – Satellite
- Product Link – Dual

For more complete information on Cat products, dealer services, and industry solutions, visit us on the web at www.cat.com

AEHQ7454 (04-2015)

© 2015 Caterpillar
All rights reserved

Materials and specifications are subject to change without notice. Featured machines in photos may include additional equipment. See your Cat dealer for available options.

CAT, CATERPILLAR, SAFETY.CAT.COM, their respective logos, "Caterpillar Yellow" and the "Power Edge" trade dress, as well as corporate and product identity used herein, are trademarks of Caterpillar and may not be used without permission.

VisionLink is a trademark of Trimble Navigation Limited, registered in the United States and in other countries.



Courtesy of Machine.Market